



EVK-L2

TOBY-L2 series LTE/DC-HSPA+/EGPRS cellular evaluation kits

User guide



Abstract

This guide explains how to set up the EVK-L2x Evaluation Kits to begin evaluating the u-blox TOBY-L2 series LTE/DC-HSPA+/EGPRS cellular modules

Document information

Title	EVK-L2	
Subtitle	TOBY-L2 series LTE/DC-HSPA+/EGPRS cellular evaluation kits	
Document type	User guide	
Document number	UBX-14000422	
Revision and date	R12	30-Sep-2021
Disclosure restriction	C1-Public	

Product status	Corresponding content status	
In development / Prototype	Objective specification	Target values. Revised and supplementary data will be published later.
Engineering sample	Advance information	Data based on early testing. Revised and supplementary data will be published later.
Initial production	Early production information	Data from product verification. Revised and supplementary data may be published later.
Mass production / End of life	Production information	Document contains the final product specification.

This document applies to the following products:

Product name	Ordering code	Firmware version	Application version	PCN reference	Product status
EVK-L20	EVK-L20-00S-02	15.90	A01.00	UBX-15029946	End of Life
		15.90	A01.10	UBX-16031212	End of Life
		17.00	A01.01	UBX-21036626	Mass production
EVK-L21	EVK-L21-00S-02	15.63	A01.03	UBX-15029946	End of Life
		15.63	A01.10	UBX-16031212	End of Life
		17.00	A01.01	UBX-21036626	Mass production
	EVK-L21-62S-01	16.05	A01.02	UBX-17003573	End of Life
EVK-L22	EVK-L22-00S-00	09.93	A01.07	UBX-15021135	End of Life
		20.06	A01.01	UBX-21036626	Mass production
EVK-L23	EVK-L23-00S-02	15.63	A01.03	UBX-15029946	End of Life
		15.63	A01.10	UBX-16031212	End of Life
		17.00	A01.01	UBX-21036626	Mass production
EVK-L24	EVK-L24-00S-01	15.93	A01.00	UBX-16025501	End of Life
		16.25	A01.00	UBX-20058840	Mass production

u-blox or third parties may hold intellectual property rights in the products, names, logos and designs included in this document. Copying, reproduction, modification or disclosure to third parties of this document or any part thereof is only permitted with the express written permission of u-blox.

The information contained herein is provided "as is" and u-blox assumes no liability for its use. No warranty, either express or implied, is given, including but not limited to, with respect to the accuracy, correctness, reliability and fitness for a particular purpose of the information. This document may be revised by u-blox at any time without notice. For the most recent documents, visit www.u-blox.com.

Copyright © u-blox AG.

Contents

Document information	2
Contents	3
1 Starting up	4
1.1 EVK-L2 overview	4
1.2 EVK-L2 block diagram	6
1.3 Switches, jumpers, and buttons	7
1.4 LEDs.....	7
1.5 Connectors	8
1.6 EVK-L2 pin out.....	9
1.7 Software installation	10
1.8 Board setup	11
1.9 Enabling error result codes	12
1.10 PIN code insertion (when required).....	12
1.11 Registration on a cellular network.....	13
1.12 Enable audio codec configuration to provide voice capability	13
1.13 Switching off the EVK-L2.....	13
Appendix	14
A Setting up AT terminal applications for communication with EVK-L2	14
B EVK-L2 setup for Internet browsing (Windows)	15
C EVK-L2 setup for Internet browsing (Linux)	19
D Optimal throughput	21
E Examples of AT commands	22
E.1 Enable communication between cellular and Wi-Fi module	22
F Current consumption measurement	23
G Glossary	24
Declaration of conformities	25
Related documentation	26
Revision history	26
Contact	27

1 Starting up

1.1 EVK-L2 overview

The EVK-L2 kits are powerful and easy-to-use tools that simplify the evaluation of u-blox TOBY-L2 series multimode LTE/DC-HSPA+/EGPRS cellular modules.

The evaluation kits differ depending on which TOBY-L2 series module is mounted:

- EVK-L20 evaluation kit is for evaluation of TOBY-L200, in details:
 - EVK-L20-00S-02 evaluation kit is for evaluation of TOBY-L200-03S
- EVK-L21 evaluation kit is for evaluation of TOBY-L210, in details:
 - EVK-L21-00S-02 evaluation kit is for evaluation of TOBY-L210-03S
 - EVK-L21-62S-01 evaluation kit is for evaluation of TOBY-L210-62S
- EVK-L22 evaluation kit is for evaluation of TOBY-L201, in details:
 - EVK-L22-00S-00 evaluation kit is for evaluation of TOBY-L201-02S
- EVK-L23 evaluation kit is for evaluation of TOBY-L280, in details:
 - EVK-L23-00S-02 evaluation kit is for evaluation of TOBY-L280-03S
- EVK-L24 evaluation kit is for evaluation of TOBY-L220, in details:
 - EVK-L24-00S-01 evaluation kit is for evaluation of TOBY-L220-02S

This document identifies all the EVK-L20, EVK-L21, EVK-L22, EVK-L23 and EVK-L24 evaluation kits as EVK-L2.

This section describes the main connections and settings required to get started.

 See the TOBY-L2 series data sheet [\[3\]](#) and TOBY-L2 / MPCI-L2 series system integration manual [\[4\]](#) for the features supported by u-blox TOBY-L2 series LTE/DC-HSPA+/EGPRS cellular modules.

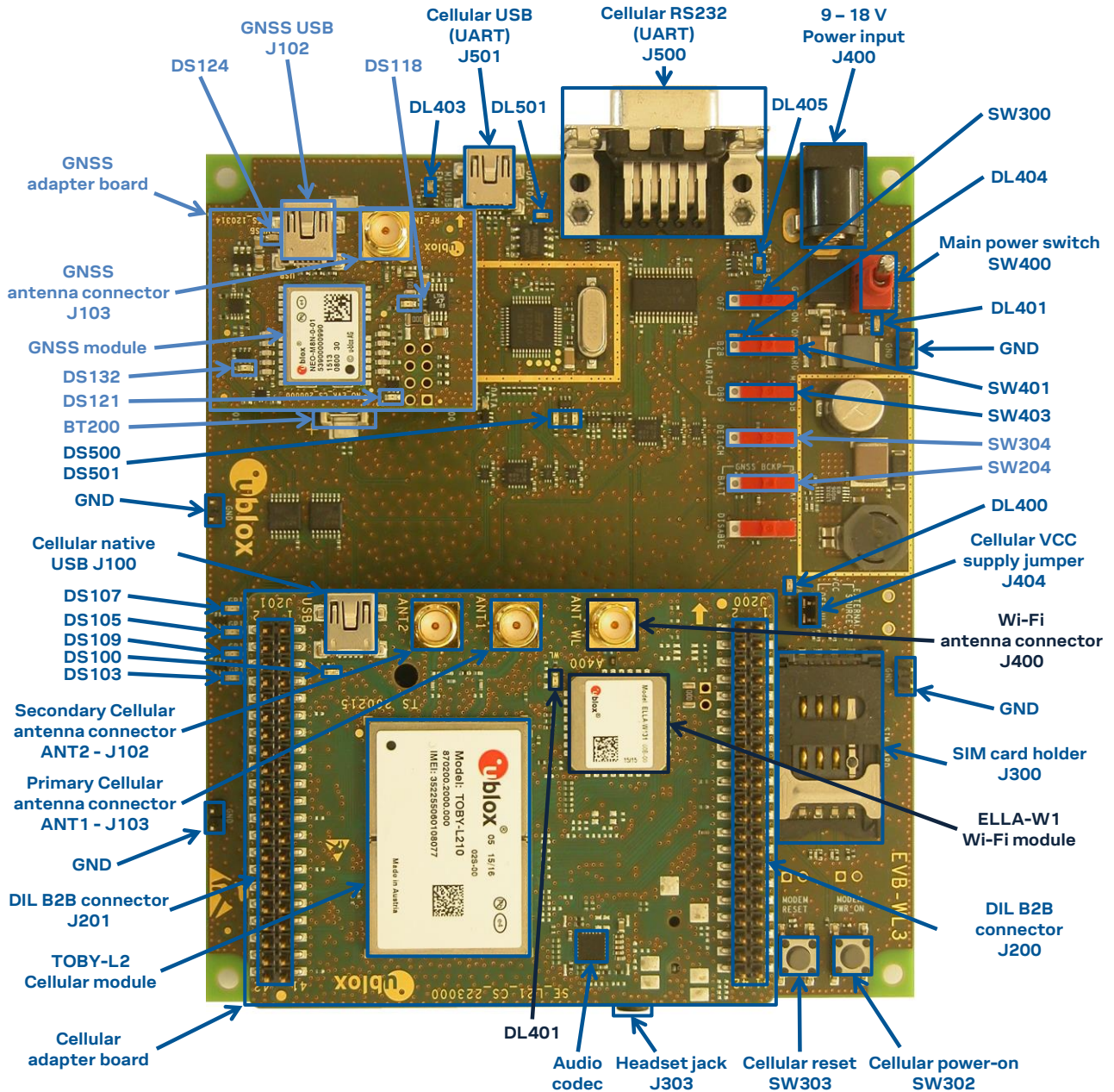

Figure 1: Overview of EVK-L2 evaluation kit for TOBY-L2 modules



The u-blox ELLA-W1 Wi-Fi module and related parts are not installed on the EVK-L24.

1.2 EVK-L2 block diagram

Figure 2 shows the main interfaces and internal connections of the EVK-L2 evaluation kit:

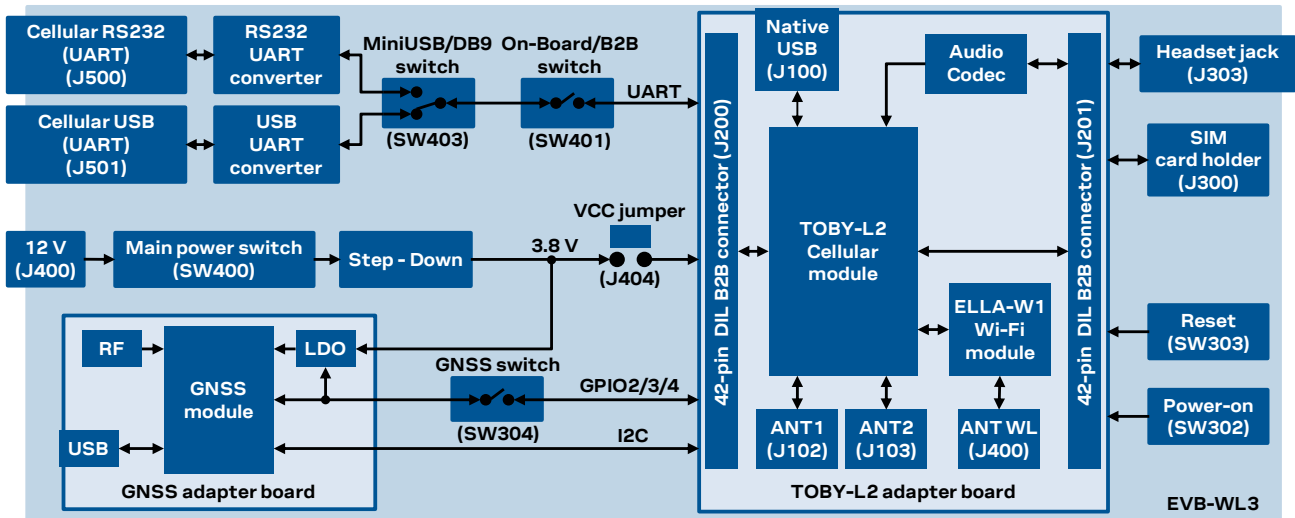

Figure 2: Block diagram of EVK-L2 for TOBY-L2 modules

The EVK-L2 is formed by three boards:

- The lower one, called EVB-WL3, contains the power supply and other peripherals for the TOBY-L2 series cellular module (SIM card holder, Reset button and Power-on button).
- The cellular adapter board, called ADP-L2, contains the TOBY-L2 series cellular module, the cellular antenna connectors, and the USB connector for the cellular module. It also contains the u-blox ELLA-W1 series Wi-Fi module and the Wi-Fi antenna connector (except for the EVK-L24), and an audio codec.
- The GNSS adapter board, called ADP-GNSS, contains the u-blox GNSS module, the GNSS antenna connector, and the USB connector for the GNSS module.

The boards are connected by means of male header board-to-board connectors provided on the bottom of the adapter boards and their corresponding female connectors provided on top of the lower board.

The USB interface of the cellular module is available on the native USB connector on the cellular adapter board, while the other peripherals are available on the Dual-In-Line male Board-to-Board connectors provided on the top layer of the cellular Adapter Board (J300 / J301 or J200 / J201), which are pin-to-pin compatible to the connectors on the bottom layer of the adapter board.

The lower board (EVB-WL3) is designed to also be used with other u-blox cellular adapter boards. It contains additional switches, jumpers, connectors, LEDs and parts that are partially described in [Figure 1](#), [Figure 2](#) or in this document, because they are intended for use only with other u-blox cellular modules. It is recommended to leave any additional connector unconnected, and to leave any additional switch in its default configuration.

1.3 Switches, jumpers, and buttons

Function	Description	Name	Board
Main Power Switch	Power on / off of the whole evaluation kit	SW400	EVb
Cellular VCC	Jumper socket to provide the 3.8 V supply to the cellular module VCC input	J404	EVb
Cellular Power-on	Push button to switch-on the cellular module	SW302	EVb
Cellular Reset	Push button to reset the cellular module	SW303	EVb
Cellular UART detach	Slide switch to attach / detach cellular module UART from USB / RS232 connectors: when detached, UART signals available only on DIL B2B connector on ADP board	SW401	EVb
Cellular UART routing	Slide switch to select cellular module UART routing on USB or on RS232 connector	SW403	EVb
Cellular GPIO detach	Slide switch to attach / detach the cellular module GPIOs, SIM_DET from peripherals: when detached, the signals are available only on the DIL B2B connector on ADP board	SW300	EVb
Cellular GNSS detach	Slide switch to attach / detach the cellular module to the GNSS module (GPIO2-3-4): when detached, the signals are available only on DIL B2B connector on ADP board	SW304	EVb
GNSS V_BCKP	Slide switch to connect / disconnect backup battery to V_BCKP pin of GNSS module	SW204	EVb

Table 1: EVK-L2 switches and buttons description

1.4 LEDs



















Function	Description	LED #	Board	Color
Main Power	Power supply plugged in the 9 - 18 V Power Input	DL401	EVb	
Cellular VCC	Cellular module supplied. Main Power Switch must be switched on	DL400	EVb	
Cellular native USB	USB cable plugged in Cellular native USB connector	DS100	ADP-L2	
Cellular USB	USB cable plugged in Cellular USB connector for UART access	DL501	EVb	
Cellular USB / UART	Green light is activated when UART is routed to Cellular USB connector Red light blinks at UART TX or RX data on Cellular USB connector	DL403	EVb	
Cellular UART detach	UART signals are available only on the DIL B2B connector on ADP board	DL404	EVb	
Cellular RS232 / UART	Green light is activated when UART is routed to Cellular RS232 connector Red light blinks at UART TX or RX data on Cellular RS232 connector	DL405	EVb	
Cellular RI indicator	RI line turns ON (active low)	DS501	EVb	
Cellular CTS indicator	CTS line turns ON (active low)	DS500	EVb	
Cellular GPIO1 indicator	Green light is activated when cellular GPIO1 is high	DS107	EVb	
Cellular GPIO2 indicator	Green light is activated when cellular GPIO2 is high	DS105	EVb	
Cellular GPIO3 indicator	Green light is activated when cellular GPIO3 is high	DS109	EVb	
Cellular GPIO4 indicator	Green light is activated when cellular GPIO4 is high	DS103	EVb	
Wi-Fi indicator	Green light is activated when there is Wi-Fi activity	DL401	ADP-L2	
GNSS VCC supply	GNSS module supply is turned ON	DS118	ADP-GNSS	
GNSS USB	USB cable plugged in GNSS USB connector	DS124	ADP-GNSS	
GNSS Timepulse	Pulses at 1 Hz when valid GNSS fix	DS121	ADP-GNSS	
Cellular / GNSS DDC	Cellular / GNSS module communication over DDC (I2C) interface	DS132	ADP-GNSS	

Table 2: Description of EVK-L2 LEDs

1.5 Connectors



Function	Description		Name	Board	
9 - 18 V Power Input	Connector for the AC / DC power adapter of the EVK AC: 100-240 V, 0.8 A, 50-60 Hz / DC: +12 V, 2.5 A		IEC 60417-5172 Class II equipment	J400	EVb
SIM card holder	SIM card holder			J300	EVb
Primary cellular antenna	SMA connector for the cellular module primary antenna (ANT1, Tx/Rx)			J104 ¹ J103 ²	ADP-L2
Secondary cellular antenna	SMA connector for the cellular module secondary antenna (ANT2, Rx)			J1031 J1022	ADP-L2
Wi-Fi antenna	SMA connector for the Wi-Fi module antenna (ANT WL, Tx/Rx)			J4002	ADP-L2
Cellular native USB	Mini USB connector for cellular module native USB interface			J100	ADP-L2
Cellular USB (UART)	Mini USB connector for cellular module UART interface converted as USB interface			J501	EVb
Cellular RS232 (UART)	DB9 connector for cellular module UART interface converted as RS232 interface			J500	EVb
DIL B2B headers	Dual-In-Line Board-to-Board connectors for cellular module interfaces			J300-J3011 J200-J2012	ADP-L2
Cellular headset	Audio headset jack connector for cellular module audio interface			J303	EVb
GNSS antenna	SMA connector for the GNSS module antenna (GNSS Antenna)			J208	ADP-GNSS
GNSS USB	Mini USB connector for GNSS module USB interface			J102	ADP-GNSS
GNSS backup battery	Backup battery socket for the GNSS module (under GNSS adapter board)			BT200	EVb
GND	Ground terminals for probe reference			J402, J403 J405, J406	EVb

Table 3: Description of EVK-L2 connectors

-  Caution! In the unlikely event of a failure in the internal protection circuitry there is a risk of an explosion when charging fully or partially discharged battery. Replace battery when it no longer has sufficient charge for unit operation. Control the battery before use if the device has not been used for an extended period of time.
-  Caution! Risk of explosion if battery is replaced with an incorrect type. Dispose of used batteries according to the instructions!

¹ EVK-L2x evaluation kit for TOBY-L2 modules, product version "01"

² EVK-L2x evaluation kit for TOBY-L2 modules, product versions "02" / "62" onwards

1.6 EVK-L2 pin out

TOBY-L2 series		DIL B2B	TOBY-L2 series		DIL B2B	TOBY-L2 series		DIL B2B
Pin N°	Name	Name / Pin N°	Pin N°	Name	Name / Pin N°	Pin N°	Name	Name / Pin N°
1	RSVD	Not present	32	GND	J201 Pins 7-10	63	SDIO_D2	Not present ³
2	GND	J201 Pins 7-10	33	RSVD	Not present	64	SDIO_CLK	Not present ³
3	V_BCKP	J201 Pin 3	34	RSVD	Not present	65	SDIO_CMD	Not present ³
4	VUSB_DET	Not present	35	RSVD	Not present	66	SDIO_D0	Not present ³
5	V_INT	J201 Pin 36	36	RSVD	Not present	67	SDIO_D3	Not present ³
6	RSVD	Not present	37	RSVD	Not present	68	SDIO_D1	Not present ³
7	RSVD	Not present	38	RSVD	Not present	69	GND	J201 Pins 7-10
8	RSVD	Not present	39	RSVD	Not present	70	VCC	J200 Pins 7-10
9	RSVD	Not present	40	RSVD	Not present	71	VCC	J200 Pins 7-10
10	DSR	J201 Pin 18	41	RSVD	Not present	72	VCC	J200 Pins 7-10
11	RI	J201 Pin 17	42	RSVD	Not present	73	GND	J201 Pins 7-10
12	DCD	J201 Pin 11	43	RSVD	Not present	74	GND	J201 Pins 7-10
13	DTR	J201 Pin 12	44	GND	J201 Pins 7-10	75	ANT_DET	Not present
14	RTS	J201 Pin 13	45	RSVD	Not present	76	GND	J201 Pins 7-10
15	CTS	J201 Pin 14	46	GND	J201 Pins 7-10	77	RSVD	Not present
16	TXD	J201 Pin 15	47	RSVD	Not present	78	GND	J201 Pins 7-10
17	RXD	J201 Pin 16	48	RSVD	Not present	79	GND	J201 Pins 7-10
18	RSVD	Not present	49	RSVD	Not present	80	GND	J201 Pins 7-10
19	RSVD	Not present	50	I2S_WA	Not present ³	81	ANT1	Not present
20	PWR_ON	J201 Pin 29	51	I2S_TXD	Not present ³	82	GND	J201 Pins 7-10
21	GPIO1	J201 Pin 33	52	I2S_CLK	Not present ³	83	GND	J201 Pins 7-10
22	GPIO2	J201 Pin 31	53	I2S_RXD	Not present ³	84	RSVD	Not present
23	RESET_N	J200 Pin 26	54	SCL	J200 Pin 20	85	GND	J201 Pins 7-10
24	GPIO3	J201 Pin 32	55	SDA	J200 Pin 21	86	GND	J201 Pins 7-10
25	GPIO4	J201 Pin 25	56	SIM_CLK	J200 Pin 15	87	ANT2	Not present
26	HOST_SELECT0	J201 Pin 2	57	SIM_IO	J200 Pin 14	88	GND	J201 Pins 7-10
27	USB_D-	Not present	58	SIM_RST	J200 Pin 16	89	GND	J201 Pins 7-10
28	USB_D+	Not present	59	VSIM	J200 Pin 13	90	GND	J201 Pins 7-10
29	RSVD	Not present	60	GPIO5	J201 Pin 23	91	RSVD	Not present
30	GND	J201 Pins 7-10	61	GPIO6	Not present ³	92	GND	J201 Pins 7-10
31	RSVD	Not present	62	HOST_SELECT1	J201 Pin 4	93-152	GND	J201 Pins 7-10

Table 4: Interfaces of TOBY-L2 series modules, as routed on the 42-pin Dual-In-Line Board-to-Board connectors (J200, J201) available on the adapter board ADP-L2 of the EVK-L2 evaluation kit

³ 0R jumper can be populated in order to route the signal to the 42-pin Dual-In-Line Board-to-Board connectors

Signal Name	DIL B2B J201		Signal Name	Signal Name	DIL B2B J200		Signal Name
	Pin N°	Pin N°			Pin N°	Pin N°	
HOST_SELECT0	2	1	GND	Not connected	2	1	GND
Not connected	4	3	V_BCKP	Not connected	4	3	Not connected
Not connected	6	5	Not connected	Not connected	6	5	Not connected
GND	8	7	GND	VCC	8	7	VCC
GND	10	9	GND	VCC	10	9	VCC
DTR	12	11	DCD	Not connected	12	11	Not connected
CTS	14	13	RTS	SIM_IO	14	13	VSIM
RXD	16	15	TXD	SIM_RST	16	15	SIM_CLK
DSR	18	17	RI	Not connected	18	17	Not connected
Not connected	20	19	Not connected	SCL	20	19	Not connected
Not connected	22	21	Not connected	Not connected	22	21	SDA
Not connected	24	23	GPIO5	Not connected	24	23	Not connected
Not connected	26	25	GPIO4	RESET_N	26	25	Not connected
Not connected	28	27	Not connected	MIC_BIAS	28	27	MIC_GND
Not connected	30	29	PWR_ON	Not connected	30	29	Not connected
GPIO3	32	31	GPIO2	Not connected	32	31	Not connected
HOST_SELECT1	34	33	GPIO1	SPK_N	34	33	SPK_P
V_INT	36	35	Not connected	Not connected	36	35	Not connected
Not connected	38	37	Not connected	Not connected	38	37	Not connected
Not connected	40	39	Not connected	Not connected	40	39	Not connected
GND	42	41	GND	GND	42	41	Not connected

Table 5: Pin-out of the 42-pin Dual-In-Line Board-to-Board connectors (J201, J200) available on the adapter board ADP-L2 of the EVK-L2 evaluation kit for TOBY-L2 series modules

 The pins / interfaces that are not supported by a specific TOBY-L2 module product version should be not driven by an external device (see the TOBY-L2 series data sheet [3] and TOBY-L2 / MPC1-L2 series system integration manual [4] for the features supported by each TOBY-L2 module product version).

1.7 Software installation

The related USB drivers are available with the EVK-L2. Executable files can be downloaded from www.u-blox.com/evk-downloads and saved to any location on the computer hard drive. The installation can be started by running the executable file on a computer with the Windows operating system.

1.8 Board setup

1. Insert a SIM card into the **SIM card holder** (J300 on the EVB).
2. Connect a cellular antenna provided with the evaluation kit box to the **Primary cellular antenna** SMA connector on the ADP-L2 (ANT1, RF input/output for transmission and reception of LTE/3G/2G RF signals).
3. Connect a cellular antenna provided with the evaluation kit box to the **Secondary cellular antenna** SMA connector on the ADP-L2 (ANT2, RF input for the reception of the LTE RF signals as per the Down-Link MIMO 2 x 2 and for the reception of the 3G RF signals as per the Down-Link Rx diversity). Place the secondary cellular antenna far enough from the primary cellular antenna (should be more than 20 cm).
4. If the Wi-Fi functionality is required, connect the Wi-Fi antenna provided with the evaluation kit box to the **Wi-Fi antenna** SMA connector on the ADP-L2 (ANT WL). Place the Wi-Fi antenna far enough from the cellular antennas (should be more than 20 cm).



Wi-Fi functionality is available on the EVK-L2 for TOBY-L2 product versions "02", "62" onwards

5. If the GNSS functionality is required, connect the GNSS antenna provided with the evaluation kit box to the **GNSS antenna** SMA connector on the EVB. Place the GNSS antenna in a location with good sky view.



Interface to the GNSS module is not supported by TOBY-L2 modules⁴.

6. Connect the AC / DC +12 V power adapter provided with the evaluation kit to the **9 – 18 V Power Input** connector (J400 on the EVB). LED DL401 lights blue.
7. Be sure to provide a jumper socket on the **Cellular VCC supply jumper** (J404 on the EVB). This provides the connection from the 3.8 V output of the supply circuit on the EVB to the VCC input of the module.
8. To enable the board power supply, turn the **Main power switch** (SW400 on the EVB) to the ON position. LED DL400 lights green. The cellular module switches on.
9. For communication via USB, connect the USB cable to the **Cellular native USB** connector (J100 on ADP). LED DS100 on ADP lights blue. After the end of the module boot, the following devices are by default enabled with Windows (details as the ports numbering can be seen via the Windows Device Manager)⁵:
 - Modems → u-blox Composite USB Modem Interface
 - AT commands interface is available over this modem COM port
 - Network adapters → Remote NDIS based Internet Sharing Device
 - Ethernet-over-USB connection is available over this network adapter

Run an AT terminal application (e.g. the u-blox m-center tool) selecting the u-blox Composite USB Modem Interface COM port, with these settings:

- Data rate: 115200 b/s
- Data bits: 8
- Parity: N
- Stop bits: 1
- Flow control: HW

See Appendix A for how to configure the u-blox m-center AT terminal for Windows.

⁴ Supply for the GNSS module can be provided by mounting the 0R jumper R106 and removing the 0R jumper R107 on the ADP-GNSS.

⁵ A message of "driver installation fail" may appear on Windows if the USB cable has been connected before the end of the module boot, but this can be ignored as the normal operating functionality of the module will be anyway available after the end of the module boot.

10. For communication via the TOBY-L2 module's UART interface, the following connections are allowed and can be alternatively enabled in a mutually exclusive way (see [Table 6](#) for switch position and LED status):

- Connect a USB cable to mini USB connector (**Cellular USB**, J501 on EVB), LED DL501 lights blue
- Connect an RS232 cable to DB9 connector (**Cellular RS232**, J500 on EVB)

When a USB cable is connected to the mini USB connector, two COM ports are enabled in Windows (the numbering of the COM ports can be seen via the Windows Device Manager). The serial port for AT commands is available over the first numbered COM port opened by the driver.

Type of connections	SW401	SW403	LED
Access to cellular UART over the Cellular USB (UART) mini USB connector (J501)	ON BOARD	MINIUSB	DL403
Access to cellular UART over the Cellular RS232 (UART) DB9 connector (J500)	ON BOARD	DB9	DL405
Access to cellular UART on DIL Board-to-Board connector on the adapter board: cellular UART detached from USB (UART) J501 and RS232 (UART) J500 connectors	B2B	Do not care	DL404

Table 6: Serial interface configuration

Run an AT terminal application (e.g. the u-blox m-center tool) selecting the COM port, with these settings:

- Data rate: 115200 b/s
- Data bits: 8
- Parity: N
- Stop bits: 1
- Flow control: HW

See [Appendix A](#) for how to configure the u-blox m-center AT terminal for Windows.

11. If the audio functionality is required, connect the headset provided with the evaluation kit box to the **Headset jack** connector (J303 on EVB).

1.9 Enabling error result codes

Command sent by DTE (user)	DCE response (module)	Description
AT+CMEE=2	OK	Enables the cellular module to report verbose error result codes.

1.10 PIN code insertion (when required)

Command sent by DTE (user)	DCE response (module)	Description
AT+CPIN="8180"	OK	Enter the PIN code, if needed (enter the PIN of the SIM card – 8180 is written here as an example).
AT+CLCK="SC",0,"8180"	OK	Unlock the PIN at power on (the last parameter is the PIN of the SIM card – 8180 is written here as an example).
AT+CLCK="SC",1,"8180"	OK	Lock the PIN at power on (the last parameter is the PIN of the SIM card – 8180 is written here as an example).

1.11 Registration on a cellular network

Command sent by DTE (user)	DCE response (module)	Description
AT+CREG?	+CREG: 0,1 OK	Verify the network registration.
AT+COFS=0	OK	Register the module on the network. The cellular module automatically registers itself on the cellular network. This command is necessary only if the automatic registration failed (AT+CREG? returns 0,0).
AT+COFS?	+COFS: 0,0,"I TIM",7 OK	Read the operator name and radio access technology (RAT).

For further AT command examples regarding Mobile Network Operator, Radio Access Technology, and band selection and configuration, see the u-blox AT commands examples application note [\[2\]](#).

1.12 Enable audio codec configuration to provide voice capability

Command sent by DTE (user)	DCE response (module)	Description
AT+UGPIOC?	+UGPIOC: 10,15 11,15 12,15 13,15 21,16 22,255 24,255 25,0 50,12 51,12 52,12 53,12 60,7 61,14 OK	Check the configuration of I2S pins (<gpio_id>=50, 51, 52, 53): they must be configured as I2S digital audio interface (<gpio_mode> = 12, as the factory-programmed value) to provide voice capability at the headset jack connector using the external audio codec mounted on the EVK-L2. Check the configuration of the GPIO6 pin (<gpio_id>=61): it must be configured as clock output (<gpio_mode> = 14, as the factory programmed value) to provide voice capability at the headset jack connector using the external audio codec mounted on the EVK-L2.
AT+USPM?	+USPM: 1,1,0,0,2 OK	Check the audio path mode setting: both the up-link and the down-link paths must be configured as I2S digital audio interface (e.g. <main_uplink> = 1, <main_downlink> = 1, as the factory-programmed value) to provide voice capability at the headset jack connector using the external audio codec mounted on the EVK-L2.
AT+UEXTDCONF=0,1	OK	Enable the automatic configuration of the external Maxim MAX9860 audio codec mounted on the EVK-L2. The setting is saved in the non-volatile memory (NVM) and it is applied at each subsequent module power-on.
AT+CPWROFF	OK	Switch off the EVK-L2. The external Maxim MAX9860 audio codec mounted on the EVK-L2 will be fed by the 13 MHz clock provided by the GPIO6 and it will be dynamically programmed over I2C interface at any subsequent re-boot of the module and every time audio path is enabled, providing voice capability at the headset jack connector of the EVK-L2.

1.13 Switching off the EVK-L2

To switch off the EVK-L2, send the +CPWROFF AT command. Make sure to use this command before switching off the main power, otherwise settings and configuration parameters may not be saved on the EVK-L2.

Appendix

A Setting up AT terminal applications for communication with EVK-L2

The u-blox m-center cellular module evaluation tool is a powerful platform for evaluating, configuring, and testing u-blox cellular products. m-center includes an AT commands terminal for communication with the device and can be downloaded free-of-charge from our website (<http://www.u-blox.com>).

1. Follow the board setup instructions in section 1.8 to provide all the required connections and switching on the cellular module.
2. Run the m-center tool: after the m-center start-up, the Home page appears.
3. On the Home page, set up the AT COM port; for the setting values see section 1.8. Check with the Windows Device Manager to find out which COM port is being used by EVK-L2.
4. Enable the connection to u-blox cellular module by clicking on the **Connect** button.
5. Retrieve the module and network information by clicking on the **Get Info** button.
6. The module information is retrieved and displayed on Home page.
7. Click on the **AT Terminal** button, found at the upper right of the Home page. A new window opens and the AT-command terminal is now ready for communication with EVK-L2.
8. The AT terminal is ready to use. For the complete list of AT commands supported by the modules and their syntax, see the u-blox AT commands manual [1].

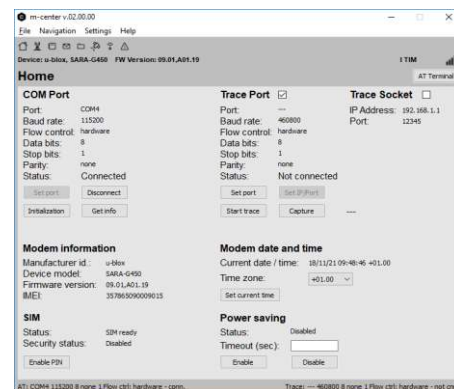

Figure 3: "Home" page

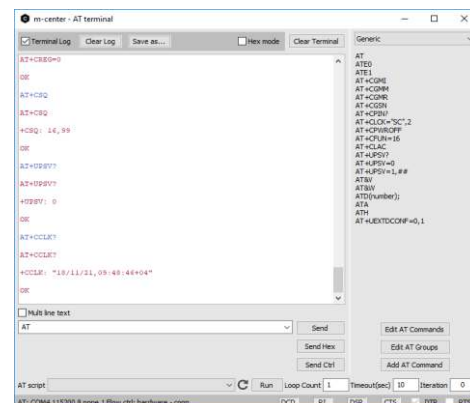

Figure 4: AT Terminal window

For more information on using the u-blox m-center cellular module evaluation tool, press the F1 key on the keyboard to open the m-center help window on the computer.

B EVK-L2 setup for Internet browsing (Windows)

This section describes how to set up the EVK-L2 for browsing the internet with Windows 7 operating system on a PC connected with the EVK-L2 over the USB physical interface of the TOBY-L2 series module. Follow the board setup instructions described in section 1.8 in order to provide communication via the USB interface of the TOBY-L2 series module. Then use the AT terminal (see appendix A) to enter the following AT command lines:

1. Perform the following procedure to activate an external PDP context with the preferred APN:

Command sent by DTE (user)	DCE response (module)	Description				
AT+UBMCONF?	+UBMCONF: 1 OK	Check the +UBMCONF <networking_mode>, which must be 1 = Router mode (as the factory-programmed value) for the context activation procedure herein described.				
AT+CFUN=4	OK	Set the module in airplane mode. The module will deregister from network and both RF Tx and RF Rx will be disabled.				
AT+CGDCONT=1,"IP","ibox.tim.it"	OK	Define a PDP context with preferred APN: in this example, the "ibox.tim.it" APN is selected.				
AT+UCGDFLT=1,"IP","ibox.tim.it"	OK	Define the initial PDP context with preferred APN. This will be activated only if the module registers to an LTE network.				
AT+CFUN=1	OK	Set the module to full functionality. The module starts the automatic network registration.				
AT+CPIN?	+CPIN: READY OK	Check the SIM PIN status and act accordingly.				
AT+COPS?	+COPS: 0,0,"I TIM",7 OK	Check the +COPS <AcT> and act accordingly: <ul style="list-style-type: none"> • If <AcT> = 7 (LTE, as it is in this example) • Then no further action is needed • Else activate the context with +CGACT as following: <table border="1" data-bbox="949 1332 1385 1400"> <thead> <tr> <th>Command sent by DTE</th> <th>DCE response</th> </tr> </thead> <tbody> <tr> <td>AT+CGACT=1,1</td> <td>OK</td> </tr> </tbody> </table> 	Command sent by DTE	DCE response	AT+CGACT=1,1	OK
Command sent by DTE	DCE response					
AT+CGACT=1,1	OK					
AT+CGCONTRDP	+CGCONTRDP: 4,5,"ibox.tim.it.mnc001.mcc222.gprs", "5.168.209.178.255.255.255.255", "5.168.209.178", "83.224.70.94", "83.224.56.132", "0.0.0.0", "0.0.0.0", 0 OK	Check the DNS primary server address: in this example, the DNS primary server address is 83.224.70.94				

 For the complete description and syntax of supported AT commands, and for further details regarding all the settings configurable by means of AT commands, see the u-blox AT commands manual [1], the u-blox AT commands examples application note [2], and the u-blox TOBY-L2 series networking modes application note [5].

- Open “Network and Sharing Center” and click on **Local Area Connection** (associated to RNDIS interface):

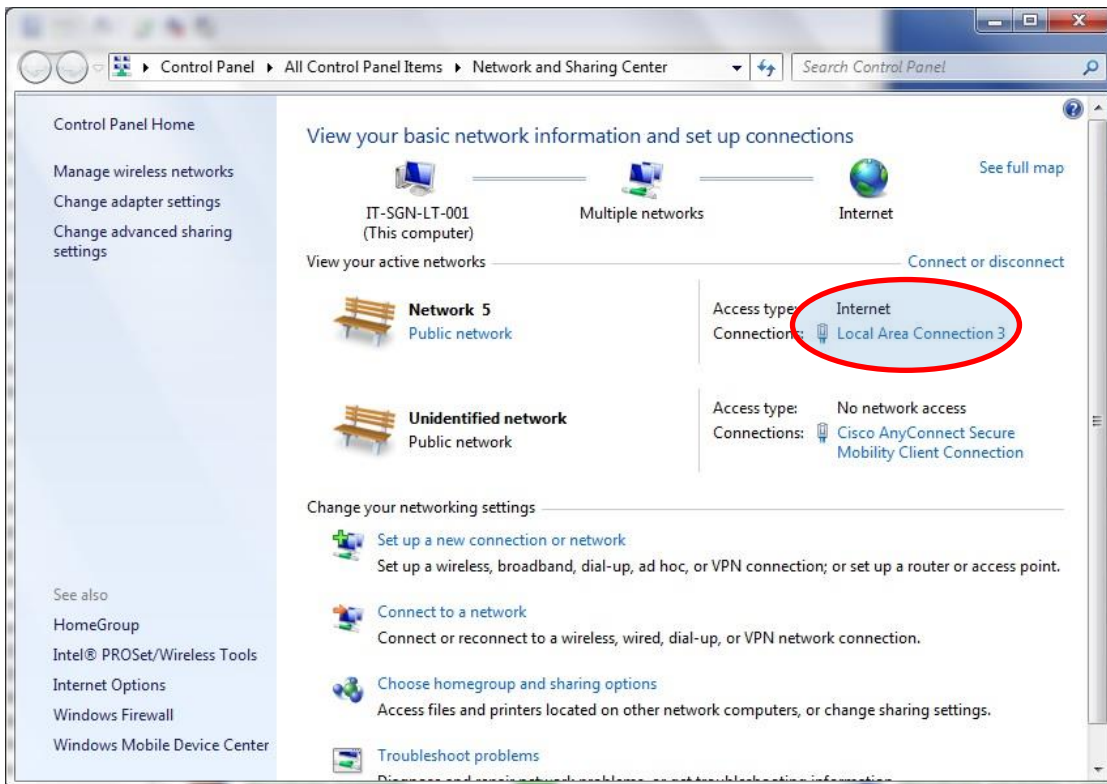

- Click on **Properties**:

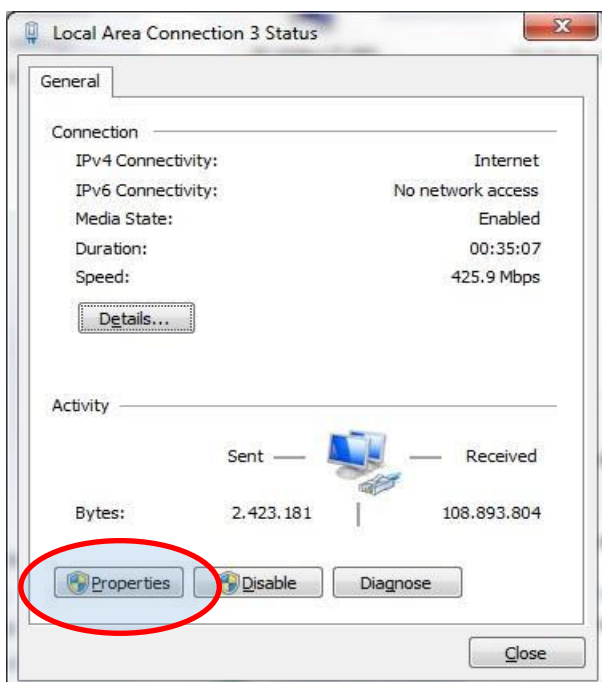

4. Search for “Internet Protocol Version 4 (TCP/IPv4)” and click on **Properties**:

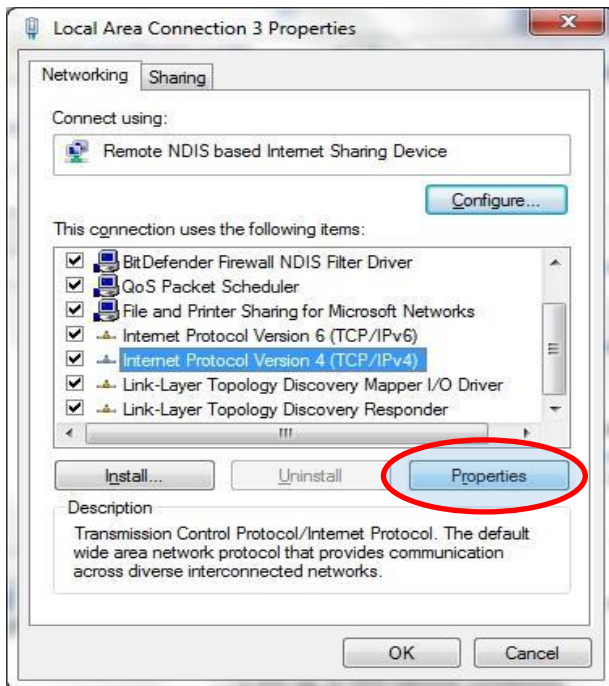

5. Check the **Obtain an IP address automatically** and **Obtain DNS server address automatically** option. This the DHCP

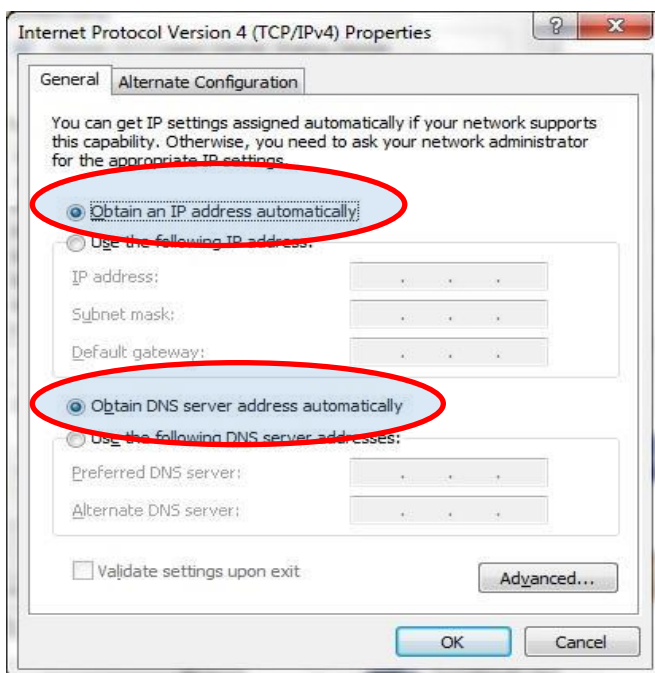

6. If it is not possible to surf the web, then manually set the DNS server address: for example, use the DNS server returned by network (in this example, 83.224.70.94)

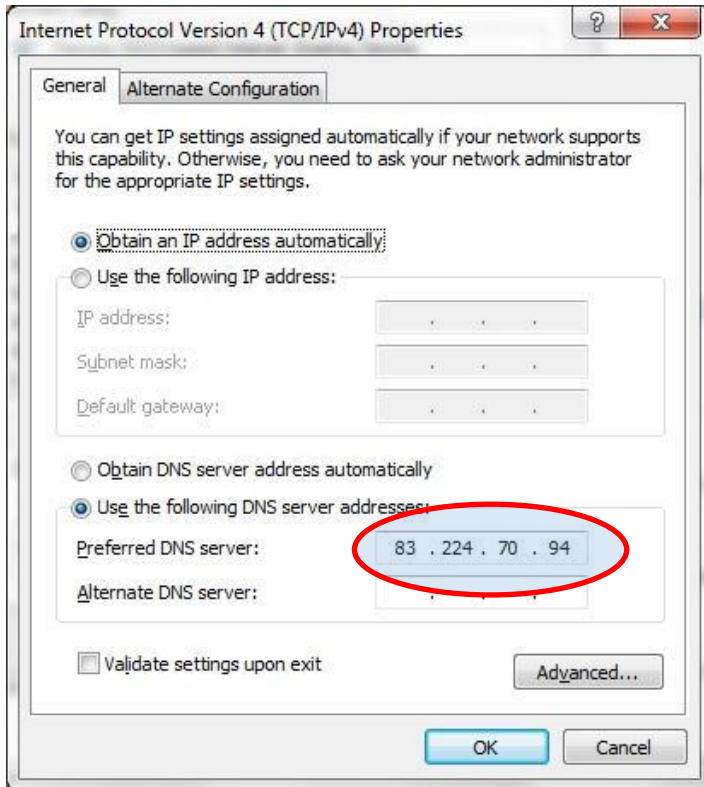

C EVK-L2 setup for Internet browsing (Linux)

This section describes how to set up the EVK-L2 for browsing the internet with a Linux operating system on a PC connected with the EVK-L2 over the USB interface of the TOBY-L2 series module. Follow the board setup instructions described in section 1.8 (except the Windows OS settings) to provide communication via the USB interface of the TOBY-L2 module. Use minicom or a similar program to send AT commands to the TOBY-L2 module.

1. Identify the CDC-ACM connected to the Linux OS (`ls /dev/ttyACM*`) and then launch minicom to use this port. In the example below the port is **ttyACM0**.

```

root@aecel-Latitude-E6230: ~
root@aecel-Latitude-E6230:~# ls /dev/ttyACM*
/dev/ttyACM0
root@aecel-Latitude-E6230:~#

root@aecel-Latitude-E6230: ~
Welcome to minicom 2.7

OPTIONS: I18n
Compiled on Jan  1 2014, 17:13:19.
Port /dev/ttyACM0, 16:42:05

Press CTRL-A Z for help on special keys

at
OK
at+uusbconf?
+UUSBCONF: 3,"RNDIS",,"0x1146"

OK
    
```

2. Use the AT terminal to enter the following AT command lines. Perform the following procedure to activate an external PDP context with the preferred APN:

Command sent by DTE (user)	DCE response (module)	Description
AT+UBMCONF?	+UBMCONF: 1 OK	Check the +UBMCONF <networking_mode>, which must be 1 (router mode as the factory-programmed value) for the context activation procedure herein described.
AT+CFUN=4	OK	Set the module in airplane mode. The module will deregister from the network and both RF Tx and RF Rx will be disabled.
AT+CGDCONT=1,"IP","ibox.tim.it"	OK	Define a PDP context with preferred APN: in this example, the "ibox.tim.it" APN is selected.
AT+UCGDFLT=1,"IP","ibox.tim.it"	OK	Define the initial PDP context with preferred APN. This will be activated only if the module registers to an LTE network.
AT+CFUN=1	OK	Set the module to full functionality. The module starts the automatic network registration.
AT+CPIN?	+CPIN: READY	Check the SIM PIN status and act accordingly.

Command sent by DTE (user)	DCE response (module)	Description				
	OK					
AT+COPS?	+COPS: 0,0,"I TIM",7 OK	Check the +COPS <Act> and act accordingly: <ul style="list-style-type: none"> • If <Act> = 7 (LTE, as it is in this example) • Then no further action is needed • Else activate the context with +CGACT as following: <table border="1" style="margin-left: 20px;"> <thead> <tr> <th>Command sent by DTE</th> <th>DCE response</th> </tr> </thead> <tbody> <tr> <td>AT+CGACT=1,1</td> <td>OK</td> </tr> </tbody> </table> 	Command sent by DTE	DCE response	AT+CGACT=1,1	OK
Command sent by DTE	DCE response					
AT+CGACT=1,1	OK					
AT+CGCONTRDP	+CGCONTRDP: 4,5,"ibox.tim.i t.mnc001.mcc222.gprs", "5.16 8.209.178.255.255.255.255", "5.168.209.178", "83.224.70. 94", "83.224.56.132", "0.0.0. 0", "0.0.0.0",0 OK	Check the DNS primary server address: in this example, the DNS primary server address is 83.224.70.94				

For the complete description and syntax of supported AT commands, and for further details regarding all the settings configurable by means of AT commands, see the u-blox AT commands manual [1], the u-blox AT commands examples application note [2], and the u-blox TOBY-L2 series networking modes application note [5].

- Use the command `ifconfig` to check if the RNDIS is active or not: in the example below it is not active because it is not listed.
- Open a terminal and use the command `"dmesg | grep rndis"` to identify the interface associated with the RNDIS. In the example below the interface is **usb0**.

```

root@aecel-Latitude-E6230: ~
ae-cel@aecel-Latitude-E6230:~$ sudo -s
[sudo] password for ae-cel:
root@aecel-Latitude-E6230:~# ifconfig
lo          Link encap:Local Loopback
            inet addr:127.0.0.1  Mask:255.0.0.0
            inet6 addr: ::1/128 Scope:Host
            UP LOOPBACK RUNNING MTU:65536 Metric:1
            RX packets:6908 errors:0 dropped:0 overruns:0 frame:0
            TX packets:6908 errors:0 dropped:0 overruns:0 carrier:0
            collisions:0 txqueuelen:0
            RX bytes:487750 (487.7 KB)  TX bytes:487750 (487.7 KB)

root@aecel-Latitude-E6230:~# dmesg | grep rndis
[ 343.419998] rndis_host 1-1:1.0 usb0: register 'rndis_host' at usb-0000:00:14.0-1, RNDIS device, 02:02:07:15:00:0b
[ 343.420053] usbcore: registered new interface driver rndis_host
[ 675.913077] rndis_host 1-1:1.0 usb0: unregister 'rndis_host' usb-0000:00:14.0-1, RNDIS device
[ 682.067068] rndis_host 1-1:1.0 usb0: register 'rndis_host' at usb-0000:00:14.0-1, RNDIS device, 02:02:07:15:00:0b
root@aecel-Latitude-E6230:~#
    
```

- Use the command `dhclient usb0` to configure the DHCP client, now the RNDIS is active.

- Use `ifconfig` to check that RNDIS is now active.

```

root@aecel-Latitude-E6230: ~
root@aecel-Latitude-E6230:~# dhclient usb0
root@aecel-Latitude-E6230:~# ifconfig
lo          Link encap:Local Loopback
            inet addr:127.0.0.1  Mask:255.0.0.0
            inet6 addr: ::1/128 Scope:Host
            UP LOOPBACK RUNNING MTU:65536  Metric:1
            RX packets:6766 errors:0 dropped:0 overruns:0 frame:0
            TX packets:6766 errors:0 dropped:0 overruns:0 carrier:0
            collisions:0 txqueuelen:0
            RX bytes:478325 (478.3 KB)  TX bytes:478325 (478.3 KB)

usb0       Link encap:Ethernet  HWaddr 02:02:07:15:00:0b
            inet addr:192.168.1.100 Bcast:192.168.1.255  Mask:255.255.255.0
            inet6 addr: fe80::2:7ff:fe15:b/64 Scope:Link
            UP BROADCAST RUNNING MULTICAST MTU:1500  Metric:1
            RX packets:931 errors:0 dropped:0 overruns:0 frame:0
            TX packets:1203 errors:0 dropped:0 overruns:0 carrier:0
            collisions:0 txqueuelen:1000
            RX bytes:598185 (598.1 KB)  TX bytes:199434 (199.4 KB)

root@aecel-Latitude-E6230:~# ping 8.8.8.8
PING 8.8.8.8 (8.8.8.8) 56(84) bytes of data.
64 bytes from 8.8.8.8: icmp_seq=1 ttl=49 time=72.5 ms
64 bytes from 8.8.8.8: icmp_seq=2 ttl=49 time=56.2 ms
64 bytes from 8.8.8.8: icmp_seq=3 ttl=49 time=59.2 ms
^C
--- 8.8.8.8 ping statistics ---
3 packets transmitted, 3 received, 0% packet loss, time 2003ms
rtt min/avg/max/mdev = 56.286/62.718/72.574/7.082 ms
root@aecel-Latitude-E6230:~#
    
```

- Now it is possible to browse the Internet.

D Optimal throughput

To reach the highest throughput use one of these interfaces, which are listed with most optimal first:

- the RNDIS interface
- the CDC-ECM interface
- the CDC-ACM interface

The configuration can be set by means of the `+UUSBCONF` AT command (see the u-blox AT commands manual [\[1\]](#)).

 On a Linux OS to reach the highest throughput through the RNDIS, it is necessary to recompile the kernel. Apply the following modification in `/kernel/drivers/net/usb/usbnet.c`:

```
replace "size_t size = dev->rx_urb_size;" with "size_t size = (16*1024);"
```

If it is not possible to recompile the kernel, try to use the following command:

```
AT+UDCONF=67,0
```

This command disables RNDIS driver optimization and can mitigate effects in router mode only.

E Examples of AT commands

For the complete description and syntax of the AT commands supported by each TOBY L2 series cellular module product version, see the u-blox AT commands manual [\[1\]](#).

For detailed examples of AT commands for network registration and configuration, context activation, data connection management, SIM management, module interfaces configurations and other settings, see the u-blox AT commands examples application note [\[2\]](#).

For detailed examples of AT commands for TOBY L2 series cellular module networking and IP connectivity configuration, see the u-blox TOBY-L2 series networking modes application note [\[5\]](#).

E.1 Enable communication between cellular and Wi-Fi module

Command sent by DTE (user)	DCE response (module)	Description
AT+UGPIOC?	+UGPIOC: 10,15 11,15 12,15 13,15 21,16 22,255 24,255 25,0 50,12 51,12 52,12 53,12 60,7 61,14 OK	Check the configuration of the GPIO6 pin (<gpio_id> = 21): it must be configured as Wi-Fi enable (<gpio_mode> = 16, as the factory-programmed value) to provide Wi-Fi capability using the u-blox ELLA-W1 series Wi-Fi module mounted on the EVK-L2.
AT+UWCFG=1	OK	Turn on the u-blox ELLA-W1 series Wi-Fi module mounted on the EVK-L2 (by default it is turned off)

For detailed examples of AT commands for the TOBY-L2 series cellular module and the u-blox ELLA-W1 Wi-Fi module integration and configuration, see the u-blox Wi-Fi / cellular integration application note [\[6\]](#).

F Current consumption measurement

Current consumption of TOBY-L2 series module can be measured on the EVK-L2 by removing 0R jumpers **R118** and **R115** mounted on the cellular adapter board, described in [Figure 5](#).

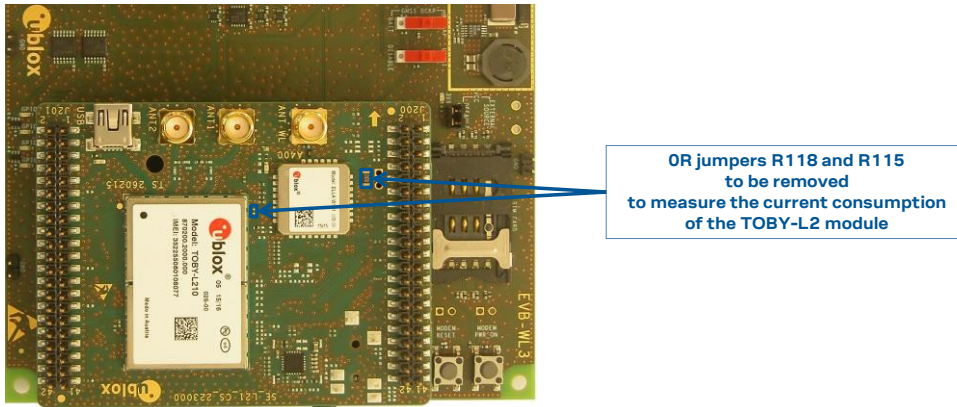

Figure 5: 0R jumpers to be removed for TOBY-L2 modules current consumption measurement

A suitable external digital multi-meter (as for example the Keysight 34465A, 34410A or 34411A) can be used for current consumption measurements: in this case the 3.8 V supply circuit on the EVB will supply the TOBY-L2 module, with the digital multi-meter placed in series as described in [Figure 6](#).

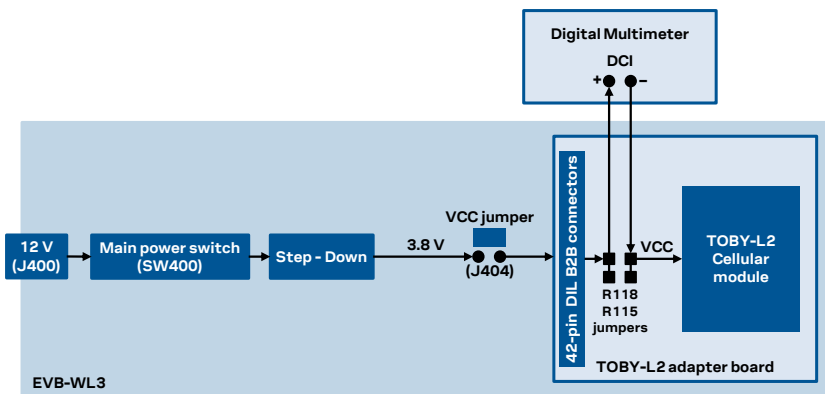

Figure 6: Block diagram of current consumption setup for TOBY-L2 modules using a multimeter

Alternatively, a suitable external DC power supply with the dynamic current measurement capabilities (as for example, the portable and cheap Qoitech Otii Arc, or the more accurate Keysight N6705B, or the models designed for mobile communications Keysight 66319B/D or 66321B/D) can be used for current consumption measurements, acting also as the 3.8 V supply source for the TOBY-L2 module mounted on the adapter board, as illustrated in [Figure 7](#).

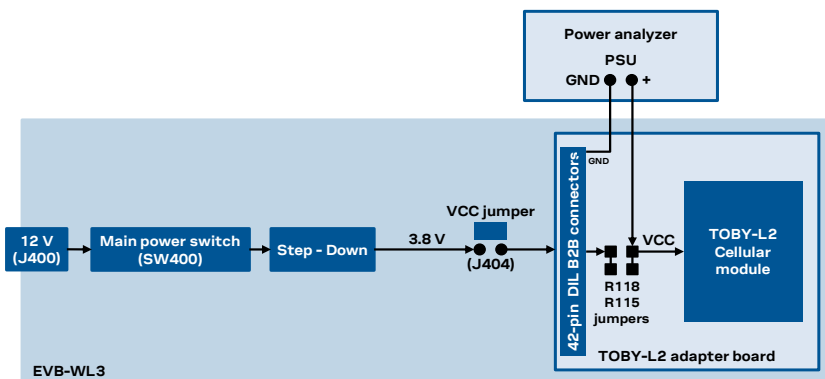

Figure 7: Block diagram of current consumption setup for TOBY-L2 modules using a DC power analyzer

G Glossary

Abbreviation	Definition
AC	Alternating Current
ACM	Application Communication Module* / Abstract Control Model*
ADP	Adapter Board
APN	Access Point Name
AT	AT Command Interpreter Software Subsystem, or attention
B2B	Board-To-Board
CDC	Communication Device Class
CTS	Clear To Send
DC	Direct Current
DCE	Data Communication Equipment
DDC	Display Data Channel
DHCP	Dynamic Host Configuration Protocol
DIL	Dual In Line
DNS	Domain Name Server
DTE	Data Terminal Equipment
ECM	Ethernet networking Control Model
EGPRS	Enhanced General Packet Radio Service
EVB	Evaluation Board
EVK	Evaluation Kit
GND	Ground
GNSS	Global Navigation Satellite System
GPIO	General Purpose Input Output
HSPA	High Speed Packet Access
I2C	Inter-Integrated Circuit
I2S	Inter-IC Sound
IP	Internet Protocol
LED	Light Emitting Diode
LTE	Long Term Evolution
MIMO	Multiple In Multiple Out
NVM	Non-Volatile Memory
PDP	Packet Data Protocol
RAT	Radio Access Technology
RI	Ring Indicator
RNDIS	Remote Network Driver Interface Specification
RX	Receiver
SIM	Subscriber Identity Module
TCP	Transfer Control Protocol
TX	Transmitter
UART	Universal Asynchronous Receiver-Transmitter
URC	Unsolicited Result Code
USB	Universal Serial Bus
Wi-Fi	Wireless Local Area Network (IEEE 802.11 short range radio technology)

Table 7: Explanation of the abbreviations and terms used

Declaration of conformities

The equipment is intended for indoor usage. It is the user's duty to verify if further restrictions apply, such as in airplanes, hospitals, or hazardous locations (such as petrol stations or refineries).

Any changes or modification made to this equipment will void its compliance to the safety requirements.

Maintenance, inspections and/or repairs of the EVK-L2 shall be performed by u-blox AG.

Related documentation

- [1] u-blox AT commands manual, [UBX-13002752](#)
- [2] u-blox AT commands examples application note, [UBX-13001820](#)
- [3] u-blox TOBY-L2 series data sheet, [UBX-13004573](#)
- [4] u-blox TOBY-L2 / MPCII-L2 series system integration manual, [UBX-13004618](#)
- [5] u-blox TOBY-L2 series networking modes application note, [UBX-14000479](#)
- [6] u-blox Wi-Fi / cellular integration application note, [UBX-14003264](#)

 For product change notifications and regular updates of u-blox documentation, register on our website, www.u-blox.com.

Revision history

Revision	Date	Name	Comments
R01	25-Mar-2014	sses	Initial release
R02	21-Jul-2014	sses	Updated document status to Advance Information, with minor corrections
R03	27-Nov-2014	sses	Updated document status to Early Production Information Updated EVK-L2 description including EVB-WL3 instead of EVB-WL1
R04	07-May-2015	sses	Added EVK-L22, EVK-L23 evaluation kits description
R05	30-Sep-2015	sses	Document status reverted to Advance Information Added description of EVK-L2 evaluation kits for TOBY-L2 product version "02" Added current consumption measurement description
R06	26-Nov-2015	mace	New section about browsing Internet on Linux OS
R07	31-Mar-2016	sses	Minor corrections and description improvements.
R08	27-Apr-2016	lpah	Updated document status to Production Information
R09	19-Apr-2017	sses	Added EVK-L21-62S and EVK-L24-00S evaluation kits description
R10	26-Jun-2017	sses	Added note about the GNSS module supply
R11	22-Jun-2021	sses	Updated modem, firmware versions, PCN references and products status. Removed description of obsolete product versions. Minor other description improvements.
R12	30-Sep-2021	alos	Updated application version and PCN reference of EVK-L20-00S-02, EVK-L21-00S-02, EVK-L22-00S-01, EVK-L23-00S-02.

Contact

For complete contact information, visit us at www.u-blox.com.

u-blox Offices

North, Central and South America

u-blox America, Inc.

Phone: +1 703 483 3180
Email: info_us@u-blox.com

Regional Office West Coast:

Phone: +1 408 573 3640
Email: info_us@u-blox.com

Technical Support:

Phone: +1 703 483 3185
Email: support@u-blox.com

Headquarters

Europe, Middle East, Africa

u-blox AG

Phone: +41 44 722 74 44
Email: info@u-blox.com
Support: support@u-blox.com

Asia, Australia, Pacific

u-blox Singapore Pte. Ltd.

Phone: +65 6734 3811
Email: info_ap@u-blox.com
Support: support_ap@u-blox.com

Regional Office Australia:

Phone: +61 3 9566 7255
Email: info_au@u-blox.com
Support: support_ap@u-blox.com

Regional Office China (Beijing):

Phone: +86 10 68 133 545
Email: info_cn@u-blox.com
Support: support_cn@u-blox.com

Regional Office China (Chongqing):

Phone: +86 23 6815 1588
Email: info_cn@u-blox.com
Support: support_cn@u-blox.com

Regional Office China (Shanghai):

Phone: +86 21 6090 4832
Email: info_cn@u-blox.com
Support: support_cn@u-blox.com

Regional Office China (Shenzhen):

Phone: +86 755 8627 1083
Email: info_cn@u-blox.com
Support: support_cn@u-blox.com

Regional Office India:

Phone: +91 80 405 092 00
Email: info_in@u-blox.com
Support: support_in@u-blox.com

Regional Office Japan (Osaka):

Phone: +81 6 6941 3660
Email: info_jp@u-blox.com
Support: support_jp@u-blox.com

Regional Office Japan (Tokyo):

Phone: +81 3 5775 3850
Email: info_jp@u-blox.com
Support: support_jp@u-blox.com

Regional Office Korea:

Phone: +82 2 542 0861
Email: info_kr@u-blox.com
Support: support_kr@u-blox.com

Regional Office Taiwan:

Phone: +886 2 2657 1090
Email: info_tw@u-blox.com
Support: support_tw@u-blox.com