

PART NO	ENGINEERING NO.	FINISHED LENGTH
1300480309	E16A06004M010	1M [3FT 3 IN]
1300480406	E16A06004M400	40M [131FT 3 IN]
1300480377	E16A06004M850	85M [278FT 10 IN]

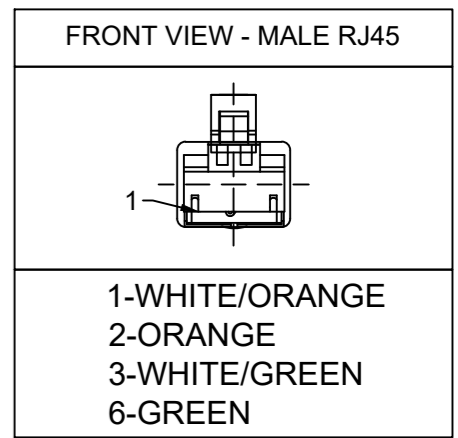

NOTES:

- MATERIAL: SEE TABLE
- FINISH: SEE TABLE
- ELECTRICAL:
VOLTAGE: 30V AC/DC
CURRENT: 1.5A
- TEMP RATING: -20°TO +75°C
- PROTECTION: IP67/69K (WHEN MATED)
- UL RECOGNIZED FILE: E200650 (A1)
- ALL DIMENSIONS ARE FOR REFERENCE UNLESS TOLERANCED OR NOTED OTHERWISE

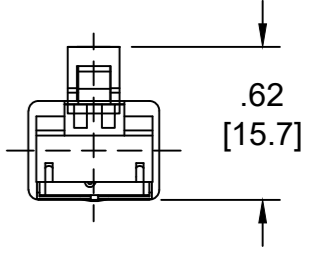
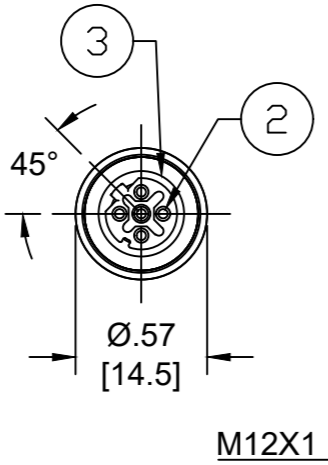
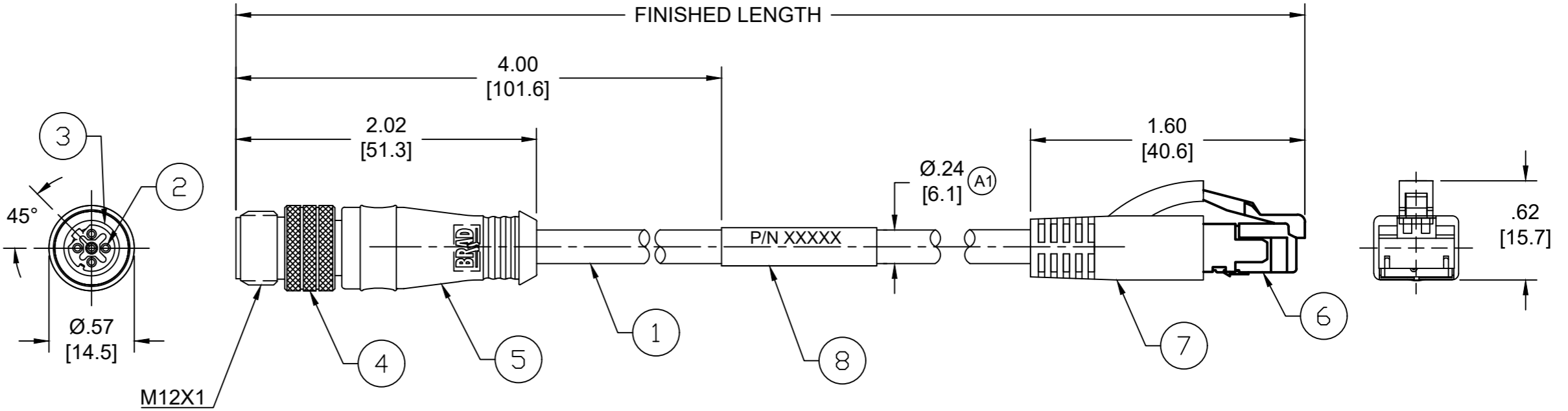

MECHANICAL CHARACTERISTICS: (A1)

FLEX LIFE:	(126 CYCLES/MIN @ 20° C) 1 MILLION CYCLE TEST (10X CABLE O.D., MINIMUM RADIUS) 10 MILLION CYCLE TEST (20X CABLE O.D., MINIMUM RADIUS)
TORSIONAL FLEX:	(1 LB LOAD, 360°, 71 CYCLES/MIN @ 20° C) 3 MILLION CYCLE TEST

PART NUMBER LEGEND
E16A06004M005
FINISHED LENGTH
M005 = 0.5 METER
M010 = 1 METER
M100 = 10 METER

(A1)

CABLE LENGTH TOLERANCES

<.3M [1FT]:	+19mm-0 [+.75in-0]
.3 - .9M [1 - 3FT]:	+44.5mm-0 [+1.75in-0]
.9 - 1.8M [3 - 6FT]:	+55.6mm-0 [+2.19in-0]
1.8 - 3.7M [6 - 12FT]:	+88.9mm-0 [+3.50in-0]
3.7 - 7.3M [12 - 24FT]:	+165.1mm-0 [+6.50in-0]
7.3-14.6M [24 - 48FT]:	+317.5mm-0 [+12.50in-0]
14.6 - 30.5M [48-100FT]:	+622.3mm-0 [+24.50in-0]
OVER 30M [100FT]	+2% OF FINISHED LENGTH

ITEM	DESCRIPTION	MATERIAL	FINISH
8	WRAP LABEL	VINYL	BLACK/WHITE
7	RJ45 BOOT, HOODED	PVC	BLACK
6	RJ45 PLUG	POLYCARBONATE	TRANSPARENT
5	OVERMOLD	PUR	BLACK
4	COUPLING NUT	BRASS	NICKEL PLATED
3	INSERT	PUR	BLACK
2	CONTACT PIN	COPPER ALLOY	GOLD OVER NICKEL
1	CABLE, ETHERNET, 24-4	TPE	TEAL

FUNCTIONAL SYMBOLS	THIS DRAWING CONTAINS INFORMATION THAT IS PROPRIETARY TO MOLEX ELECTRONIC TECHNOLOGIES, LLC AND SHOULD NOT BE USED WITHOUT WRITTEN PERMISSION		CURRENT REV DESC: ADDED BOM, UL NUMBER, CABLE DIA, MECH CHART, MATERIAL NUMBER TABLE & TOL CHART		
	$\nabla_F=0$ $\nabla_C=0$ $\nabla_P=0$	DIMENSION UNITS			
DIVISIONAL SYMBOLS	GENERAL TOLERANCES (UNLESS SPECIFIED)		INITIAL REVISION:		DOCUMENT NUMBER: SD-130048-009 DOC TYPE: PSD DOC PART: 001 REVISION: A1
	4 PLACES ±--- ±--- 3 PLACES ±--- ±--- 2 PLACES ±--- ±--- 1 PLACE ±--- ±--- 0 PLACES ±--- ±---	mm	INCH	DRWN: BARDEN 2014/02/19 APPR: JFMURPHY 2014/03/13	
DRAFT WHERE APPLICABLE MUST REMAIN WITHIN DIMENSIONS		THIRD ANGLE PROJECTION		DRAWING: B-SIZE	SERIES: 130048