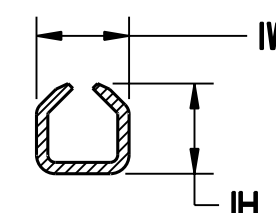
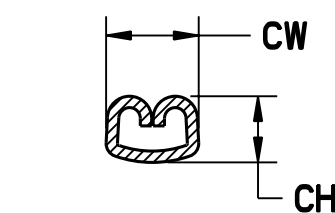
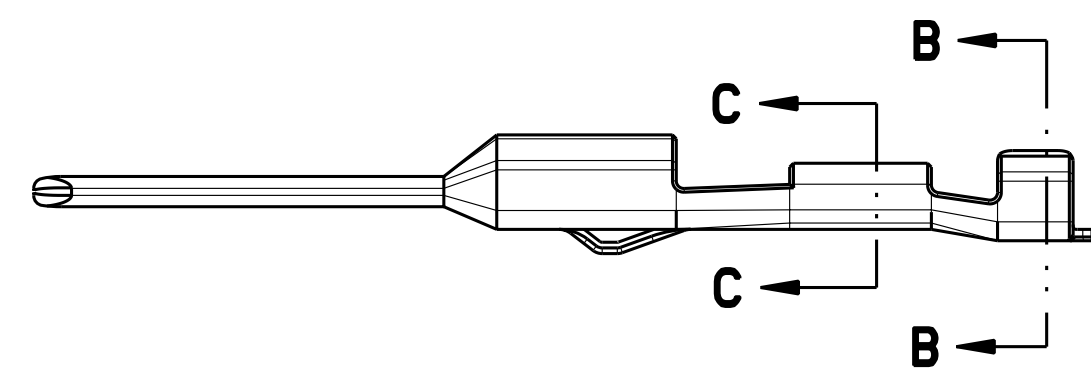
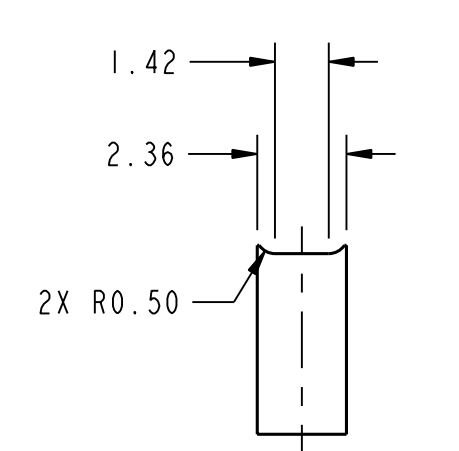

TABLE 1 - TERMINAL CRIMP DIMENSION REFERENCE TABLE

PART NO. (LEFT TO RIGHT PAYOFF)	PART NO. (RIGHT TO LEFT PAYOFF)	GRIP SIZE (ga.)	WIRE SIZE (awg)	WIRE SPECIFICATION	CONDUCTOR	CONDUCTOR	INSULATOR	INSULATOR	NOMINAL PULL TEST (N)
					CH (SEC C-C) ±0.05	CW (SEC C-C) ±0.10	IH (SEC B-B) ±0.10	IW (SEC B-B) ±0.10	
31296-0008	31296-1008	18/20	18	MIL-123A	1.25	2.15	2.40	2.45	173
31296-0008	31296-1008	18/20	20	MIL-123A	1.15	2.15	2.40	2.45	133



CRIMP INFORMATION



INSULATOR ANVIL
SCALE 5:1

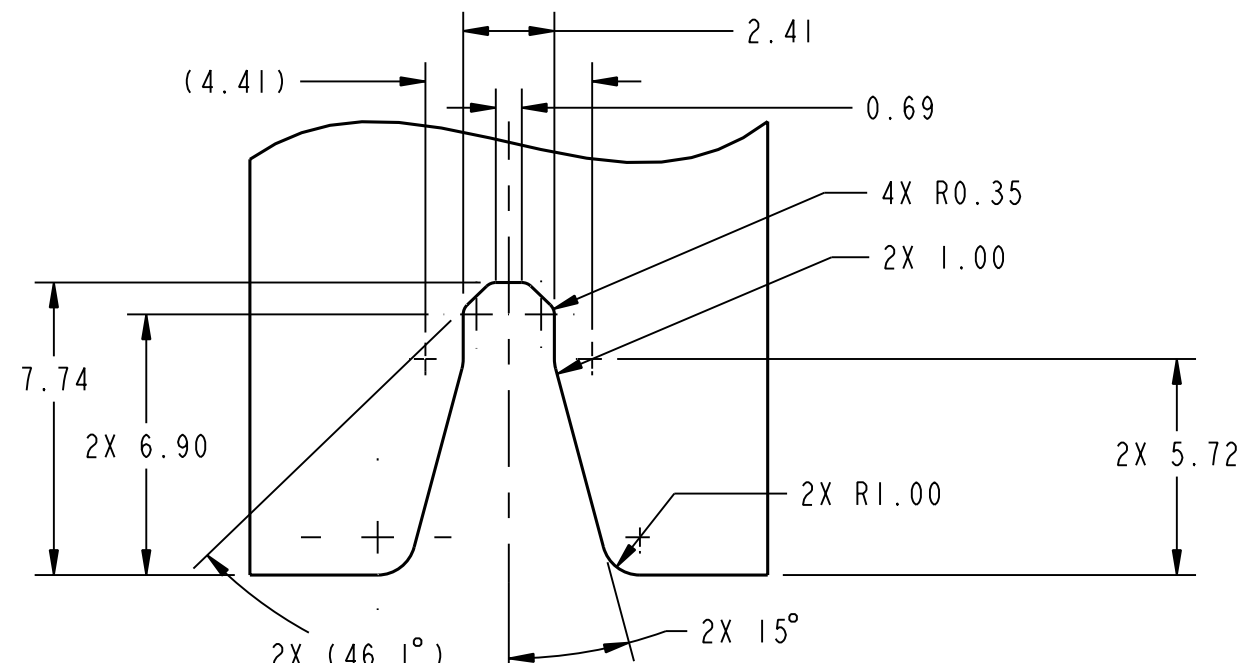

INSULATOR PUNCH

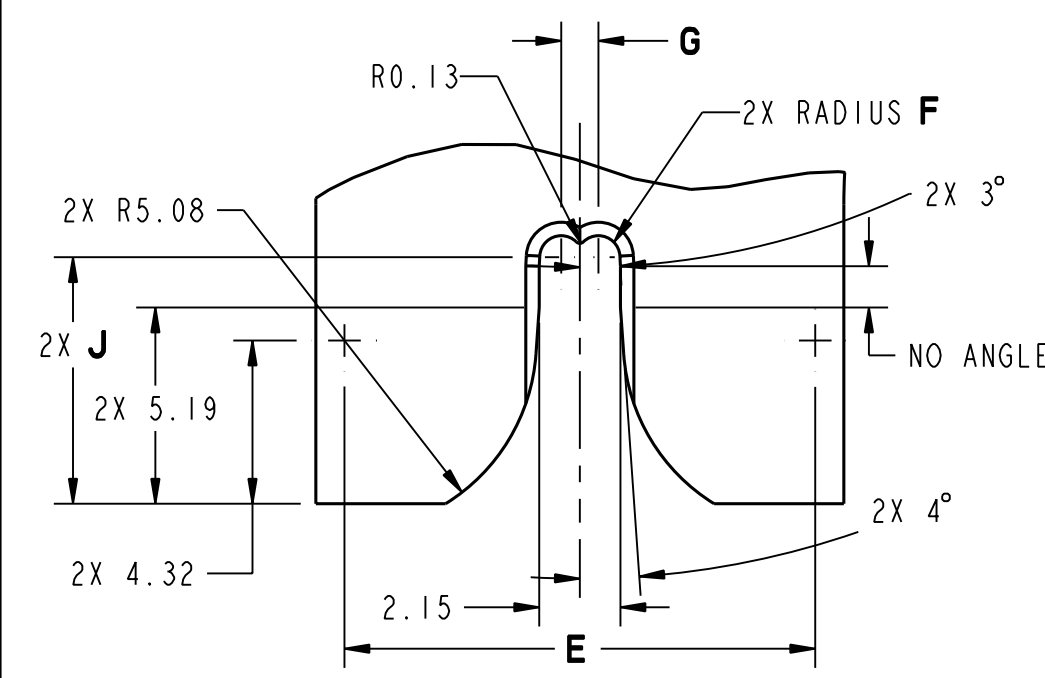

CONDUCTOR PUNCH

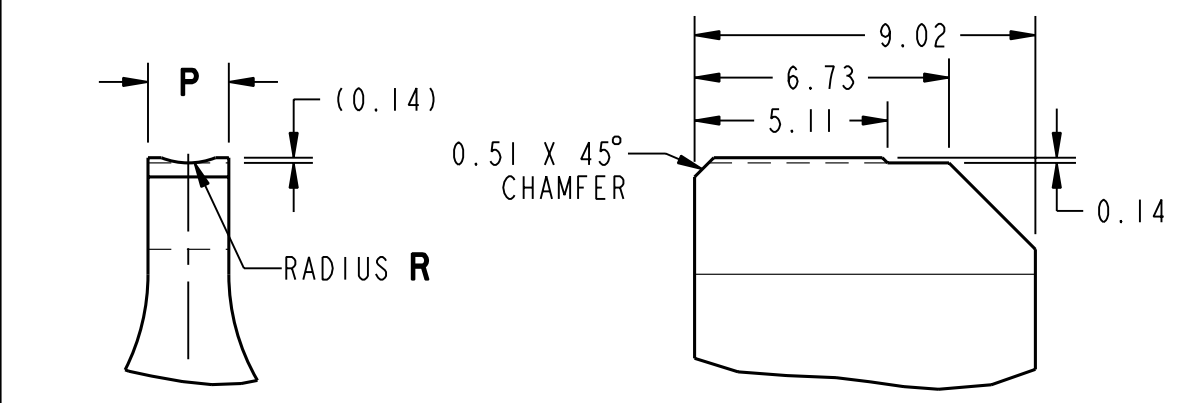

CONDUCTOR ANVIL
FRONT VIEW SCALE 5:1
CONDUCTOR ANVIL
SIDE VIEW

CRIMP TOOL INFORMATION

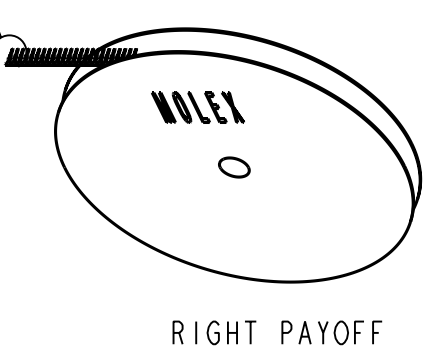
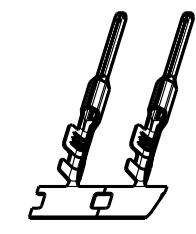
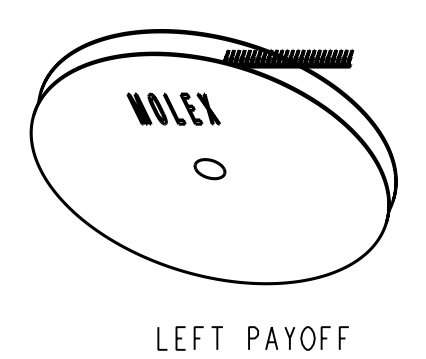

TABLE 2 - TERMINAL GRIP/CRIMP TOOL DIMENSION REFERENCE TABLE

PART NO. LEFT PAYOFF	PART NO. RIGHT PAYOFF	PLATING (STAMPING)	WIRE APPLICATION		A±0.30	B±0.30	C±0.30	D±0.30	E±0.005	F±0.005	G±0.005	J±0.005	K±0.005	M±0.005	N±0.005	P±0.005	R±0.005	U±0.005	V±0.005	
			SAE	METRIC																
31296-0008	31296-1008	GOLD	18, 20	TBD	3.3	4.5	1.3	-	12.46	0.57	0.99	6.52	-	-	-	2.14	1.94	-	-	-

PLATING NOTES:

- PRECIOUS METAL PLATING: PER MOLEX ES-88 (REVISION: REL)
 - CONTACT ZONE "B" (ELECTROPLATED GOLD OVER NICKEL)
 - ZONE "A": REDUCED THICKNESS FROM ZONE "B" IS PERMITTED. ZONE "A" SHALL BE COMPLETELY COVERED TO PREVENT EXPOSED BASE METAL
 - ZONE "B": THICKNESS 1 (1.25 - 2.25 MICROMETERS) ELECTRODEPOSITED SULFAMATE DUCTILE NICKEL (BASE LAYER)
THICKNESS 2 (0.76 MICROMETER MINIMUM) ELECTRODEPOSITED GOLD CAP
 - ZONE "C": REDUCED THICKNESS FROM ZONE "B" AND ZONE "D" IS PERMITTED. ZONE "C" SHALL BE COMPLETELY COVERED TO PREVENT EXPOSED BASE METAL
 - ZONE "D": TIN PLATING EXCEPT NICKEL THICKNESS (1.25 - 2.25 MICROMETERS); ELECTRODEPOSITED SULFAMATE DUCTILE NICKEL (BASE LAYER)
THICKNESS 2 (2.50 - 4.00 MICROMETERS); ELECTRODEPOSITED TIN (100% TIN)

- ZONE "E": REDUCED TIN THICKNESS FROM ZONE "D" IS PERMITTED. ZONE "E" SHALL BE COMPLETELY COVERED WITH NICKEL.
- ZONE "G": THICKNESS 1 (1.25 - 2.25 MICROMETERS) ELECTRODEPOSITED SULFAMATE DUCTILE NICKEL (BASE LAYER)
THICKNESS 2 (0.05 MICROMETERS MINIMUM) ELECTRODEPOSITED GOLD CAP
- ZONE "H": THICKNESS 1 (1.25 - 2.25 MICROMETERS) ELECTRODEPOSITED SULFAMATE DUCTILE NICKEL (BASE LAYER)
THICKNESS 2 (0.76 MICROMETER MINIMUM) ELECTRODEPOSITED GOLD CAP
- ZONE "J": REDUCED THICKNESS FROM ZONE "D" AND ZONE "H" PERMITTED. ZONE "J" SHALL BE COMPLETELY COVERED WITH NICKEL TO PREVENT EXPOSED BASE METAL.

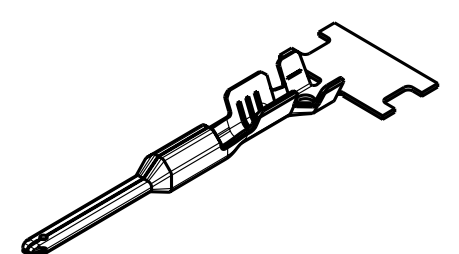

SCALE 2:1

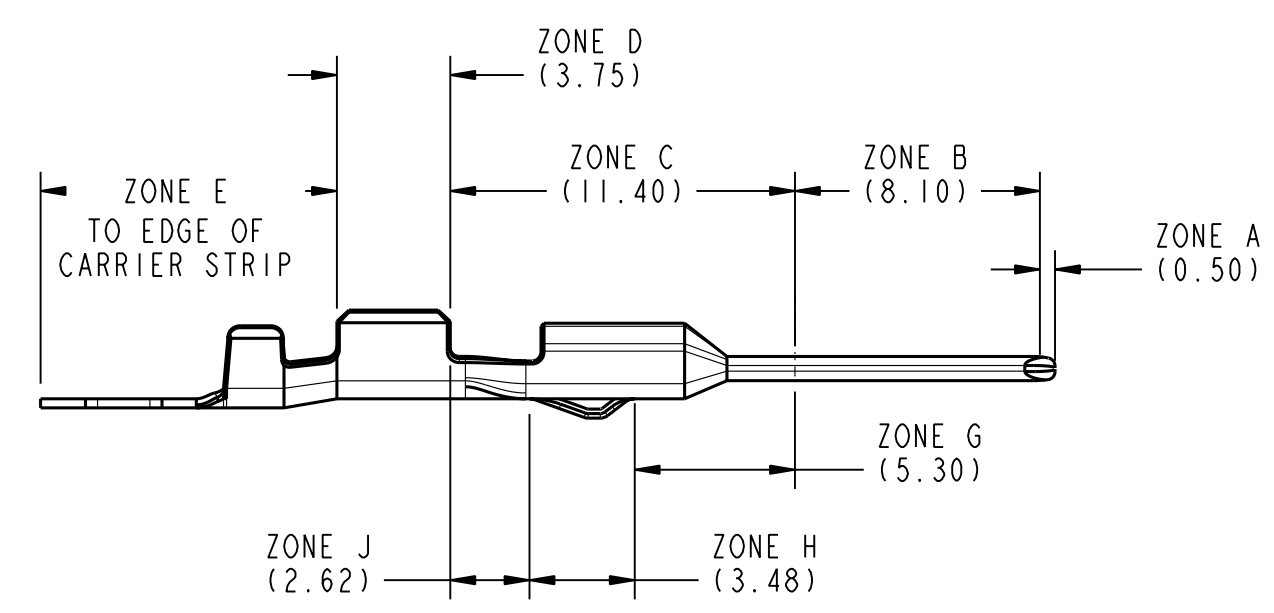

SCALE 4:1

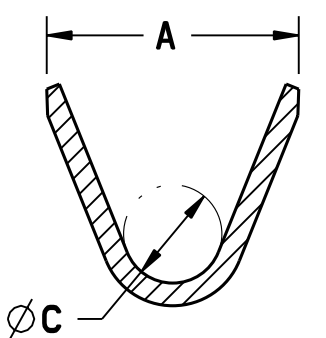

SECTION C-C
SCALE 10:1

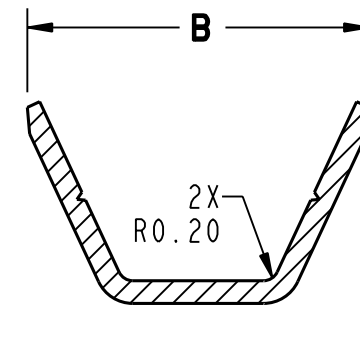

SECTION B-B
SCALE 10:1

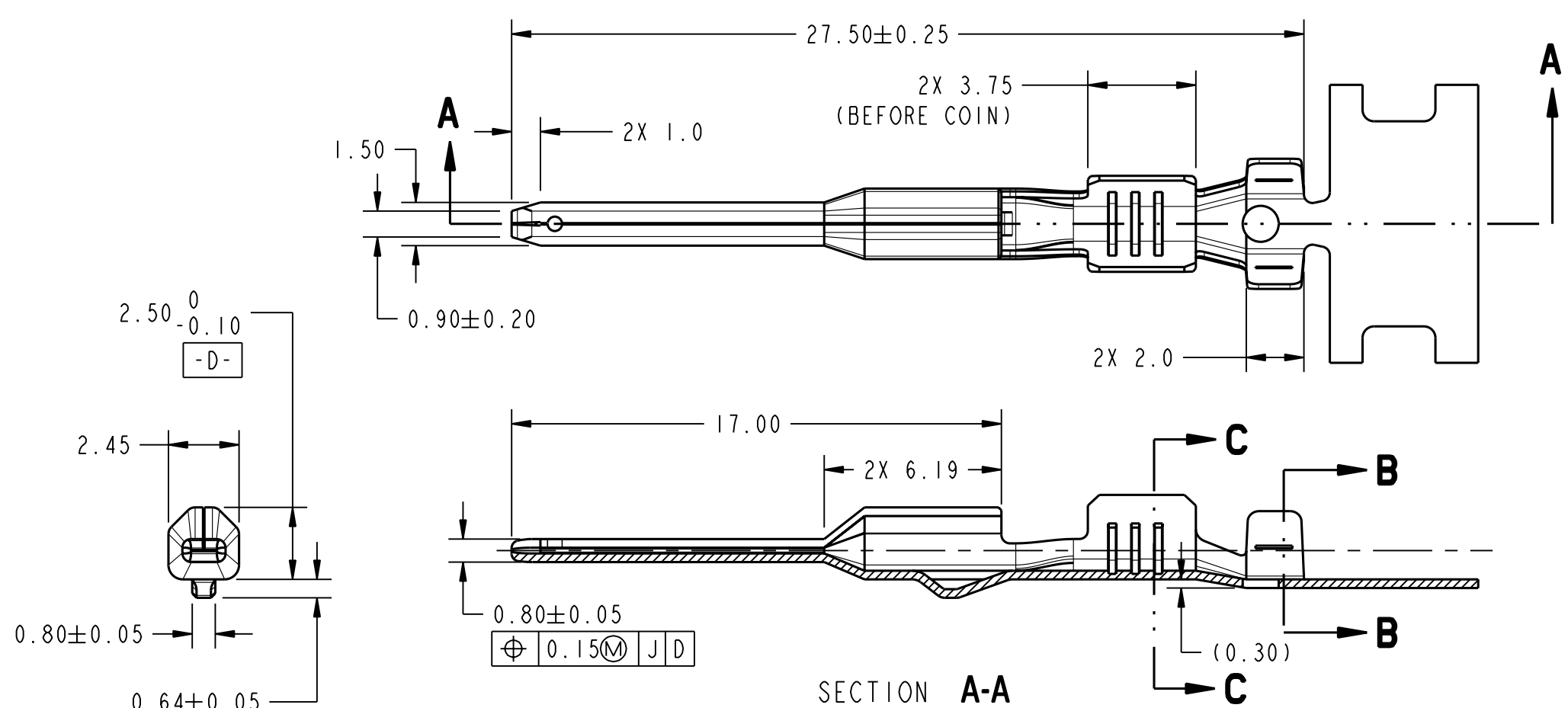

SECTION A-A

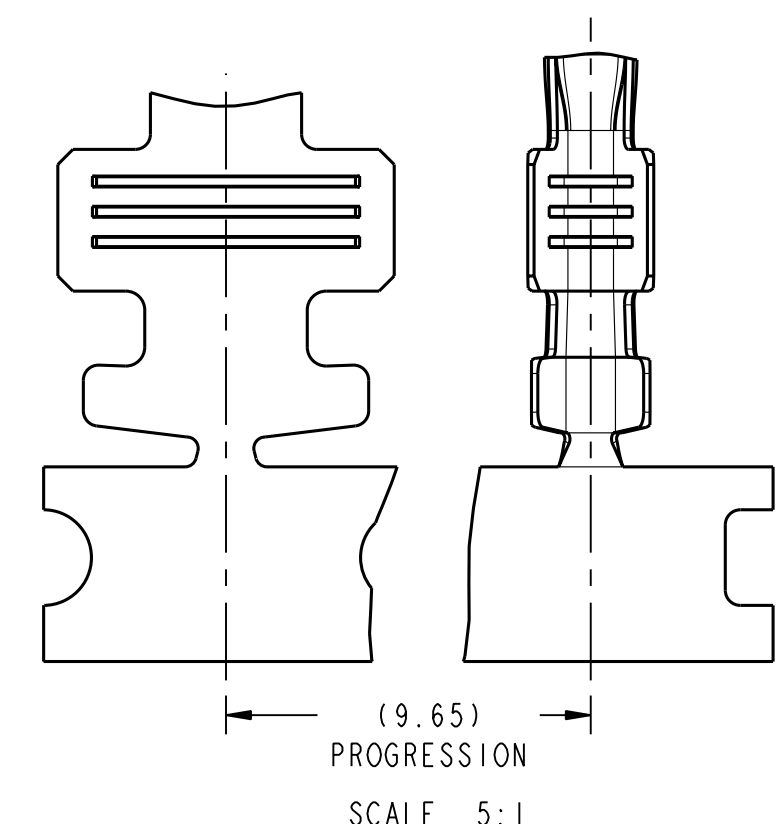

PROGRESSION
SCALE 5:1

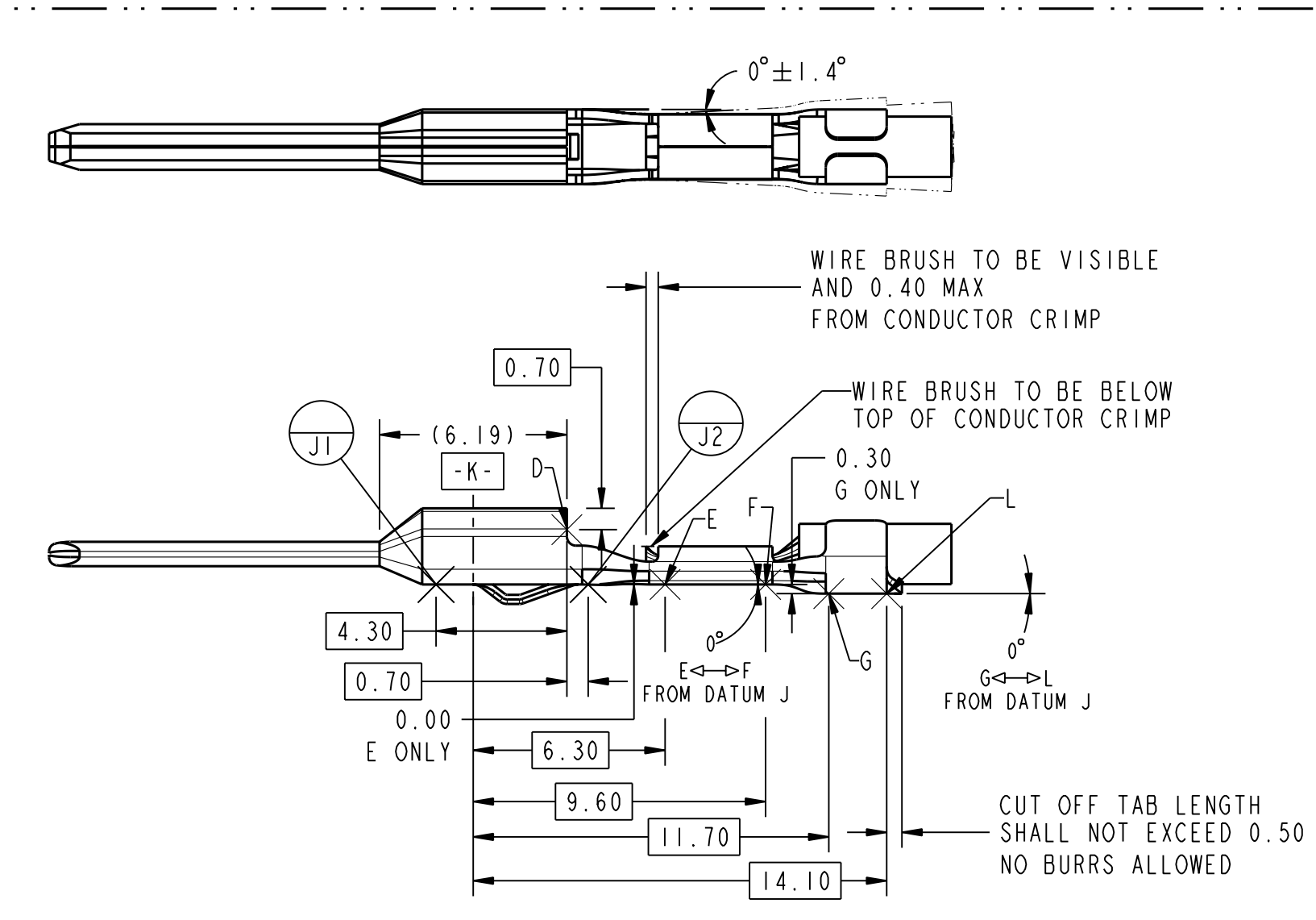

- NOTES: UNLESS OTHERWISE SPECIFIED
- MATERIAL: ASTM B422, UNS C19025, HR04
THICKNESS: 0.30 mm ±0.01
TEMPER: FULL HARD (REF.)
TENSILE: 496-572 MPA
PLATING: SEE PLATING NOTES ABOVE
 - MEETS CRIMP PERFORMANCE SPECIFICATION SAE/USCAR-21 (REL:108/29/01)
 - MEETS SAE/USCAR-2 REV 3 (TEMP CLASS 3) (REL: APRIL 2001)
SAE/USCAR-20 (REL: DECEMBER 2001)
SAE/USCAR -12 REV 2 (REL: DECEMBER 2001)
 - MEETS ELECTRICAL CONNECTION SYSTEM DESIGN SPECIFICATION (SDS) REV. 10
 - "TSC" ON A DIMENSION TO BE INTERPRETED AS DISTANCE TO A THEORETICAL SHARP CORNER AS IF THE RADIUS WERE NOT PRESENT.
 - ENGINEERING APPROVAL REQUIRED FOR ALL SOURCING AND TOOLING OF THIS PART.
 - FOR ENGINEERING APPROVED SOURCE SEE ENGINEERING RELEASE.
 - CHANGES IN DESIGN COMPOSITION OR PROCESSING FROM THE PART PREVIOUSLY APPROVED FOR PART PRODUCTION REQUIRES PRIOR ENGINEERING APPROVAL.
 - GENERAL TOLERANCES: ±0.3 ALL ONE PLACE DIMENSIONS, ±0.10 ALL TWO PLACE DIMENSIONS, ±3° ALL ANGULAR DIMENSIONS.
 - 0.2mm MAXIMUM RADIUS PERMISSIBLE ON EDGES AND FILLETS SHOWN AS SHARP FOR STAMPING PARTS.
 - ALL RADIUS 0.25 MAX.

EC NO: UAU2008-0063	QUALITY SYMBOLS	GENERAL TOLERANCES (UNLESS SPECIFIED)	SCALE 5:1	DESIGN UNITS mm	THIRD ANGLE PROJECTION	REVISE ON CAD ONLY	
DRWN: L.PULLIAM 2007/07/24	DESCRIPTION	4 PLACES ± -- ± --	DIMENSION STYLE mm	DRAWN BY DATE	TITLE	BLADE, SHORTING BAR TERMINAL MX150	
CH'K: A.DHIR 2007/07/25		3 PLACES ± -- ± --					D.GRIFFITHS 6/15/99
APPR: B.MOSER 2007/07/31		2 PLACES ± 0.10 ± --					CHECKED BY DATE
		1 PLACE ± 0.3 ± --					D.G./V.P. 7/28/99
		ANGULAR ± 3°		APPROVED BY DATE	MATERIAL NO.	DOCUMENT NO.	SHEET NO.
				V.PURUSHOTHAMAN 7/28/99	SEE CHART	SD-31296-001	1 OF 2

THIS DRAWING CONTAINS INFORMATION THAT IS PROPRIETARY TO MOLEX INCORPORATED AND SHOULD NOT BE USED WITHOUT WRITTEN PERMISSION

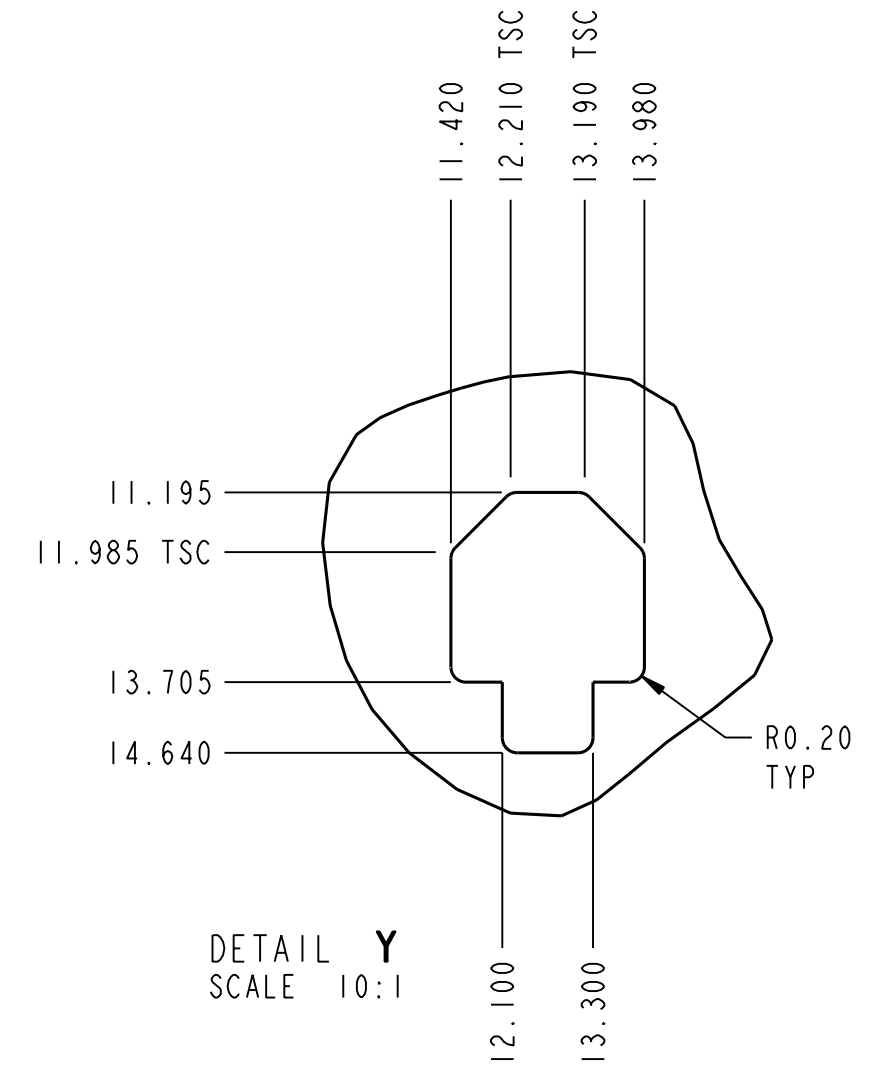
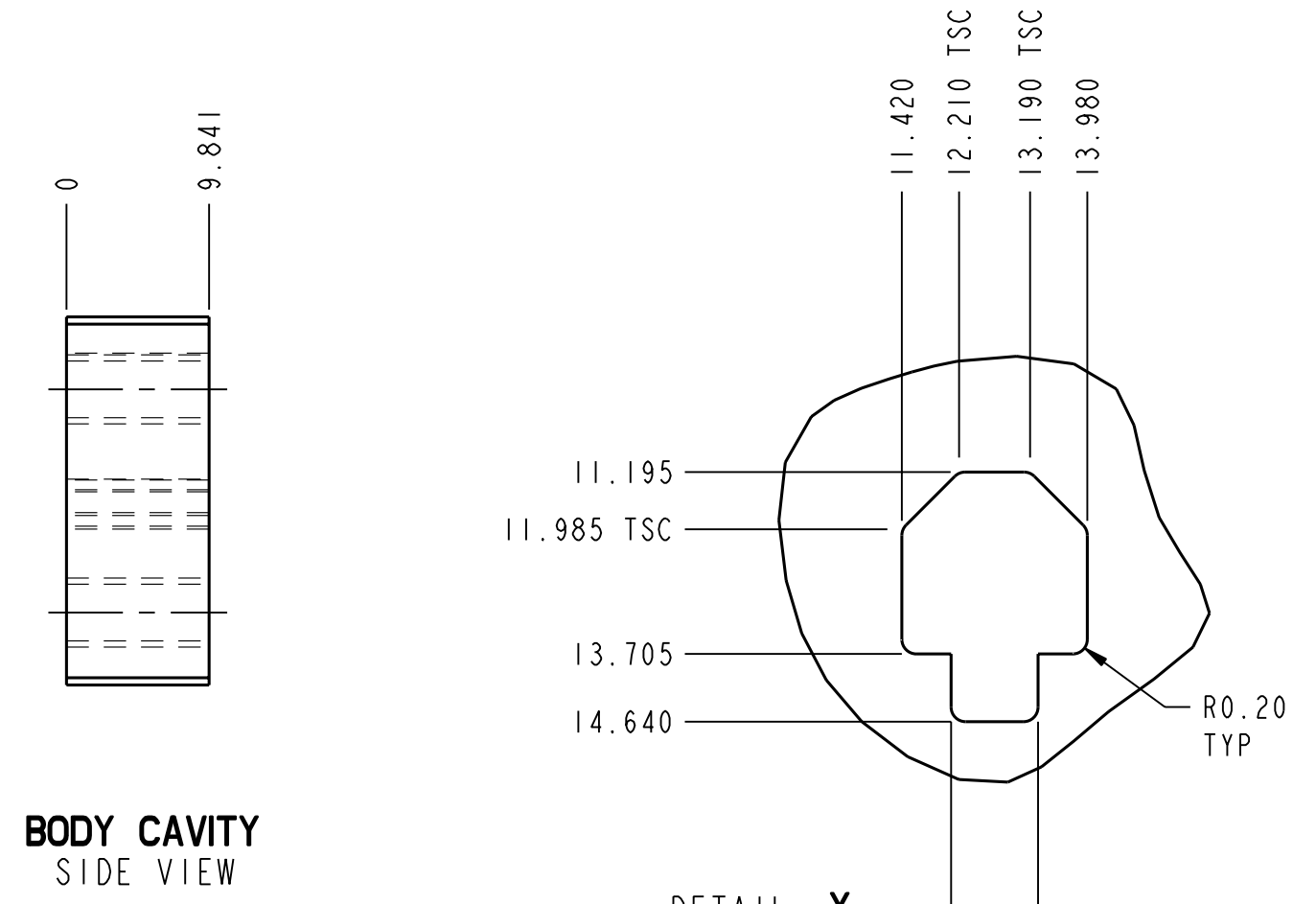
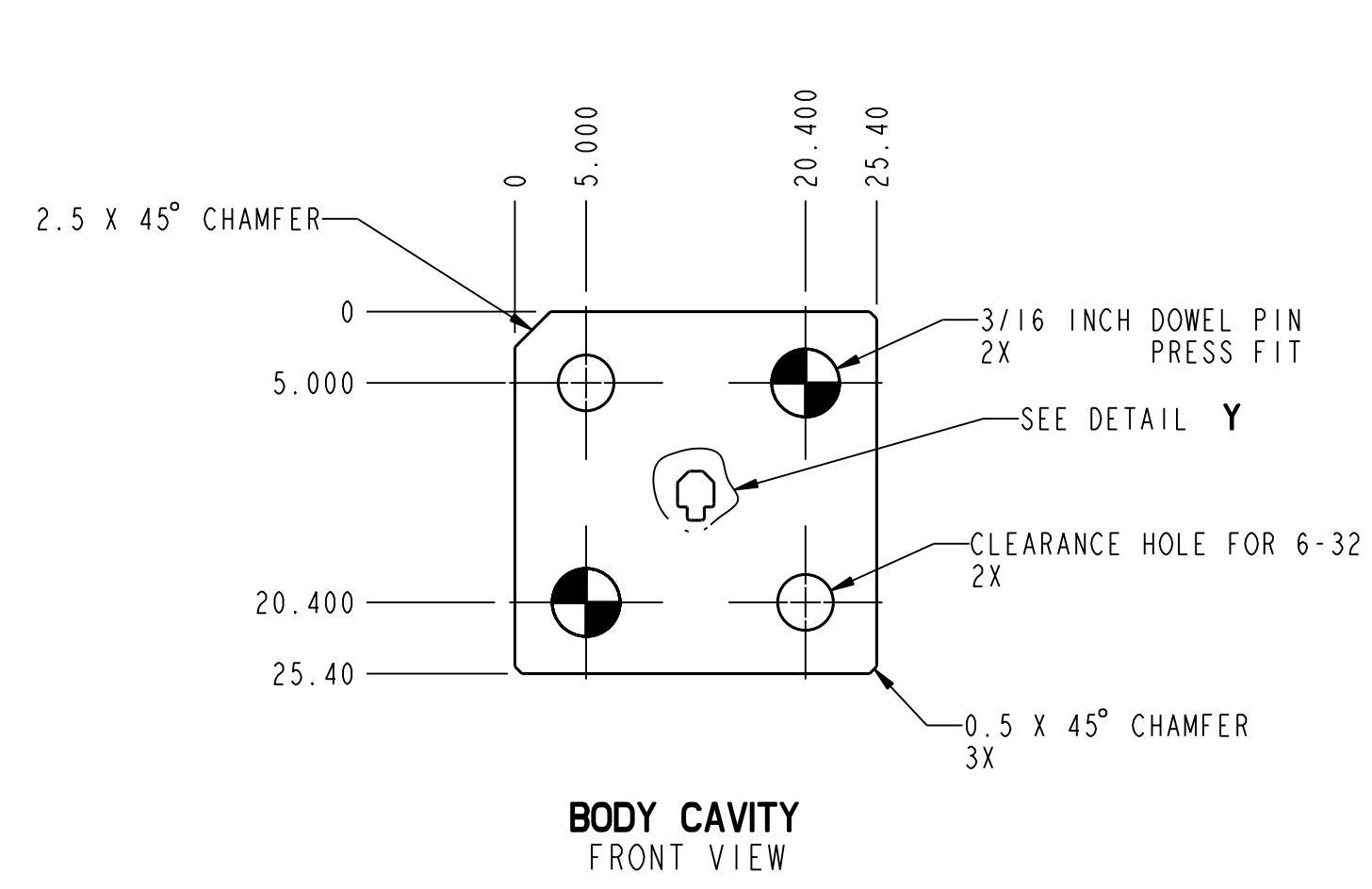

CHECKING AID		
ITEM NO.	DESCRIPTION	QUANTITY
1	ENTRY COVER	1
2	GRIP CAVITY	1
3	BODY CAVITY	1
4	PIN CAVITY	1
5	TIP COVER	1

HARDENED TOOL STEEL

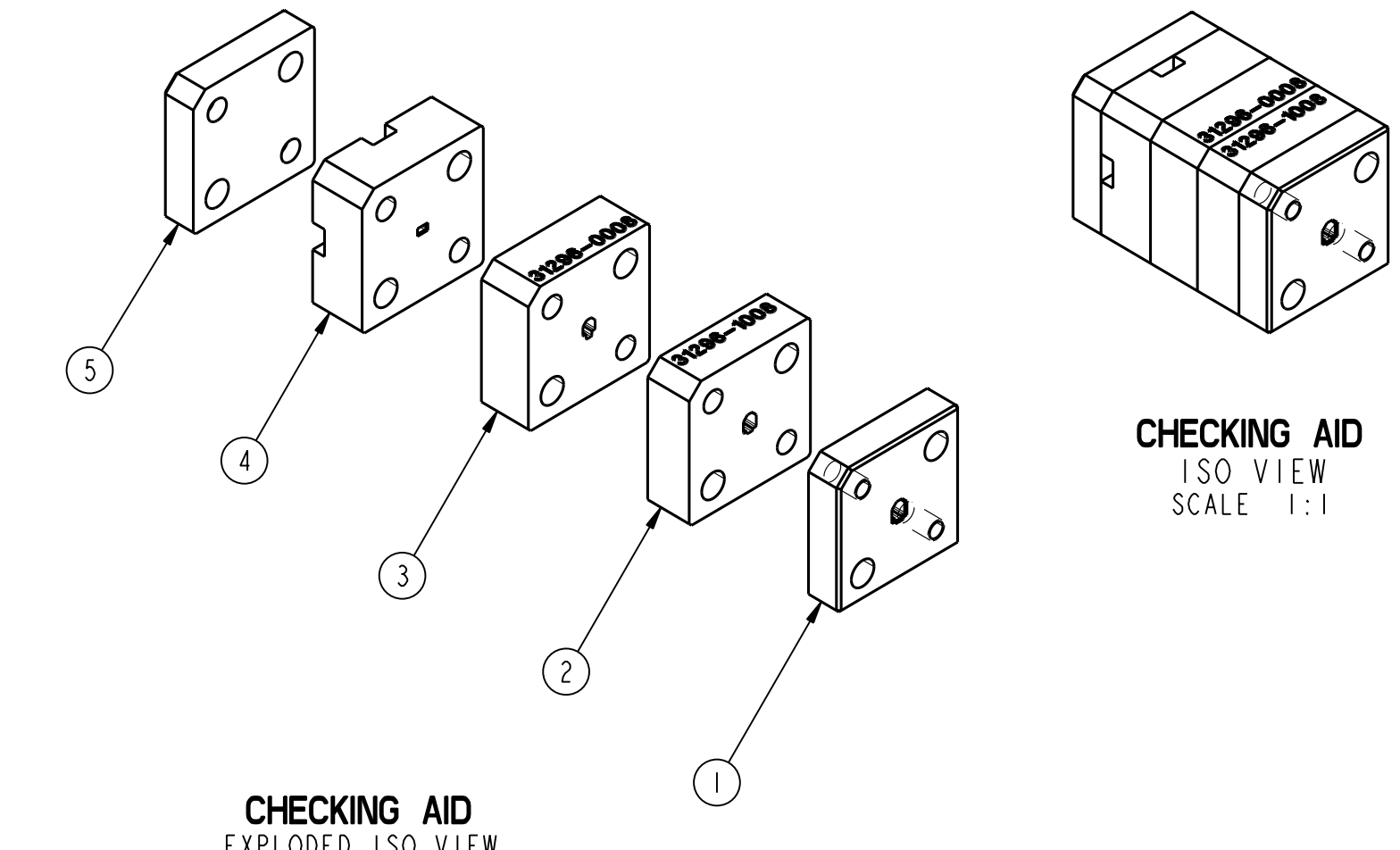

CHECKING AID
ISO VIEW
SCALE 1:1

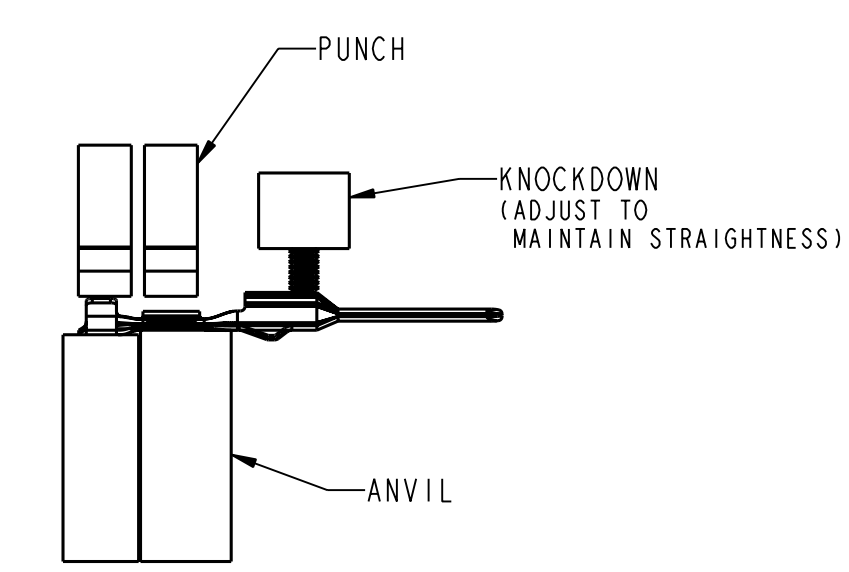
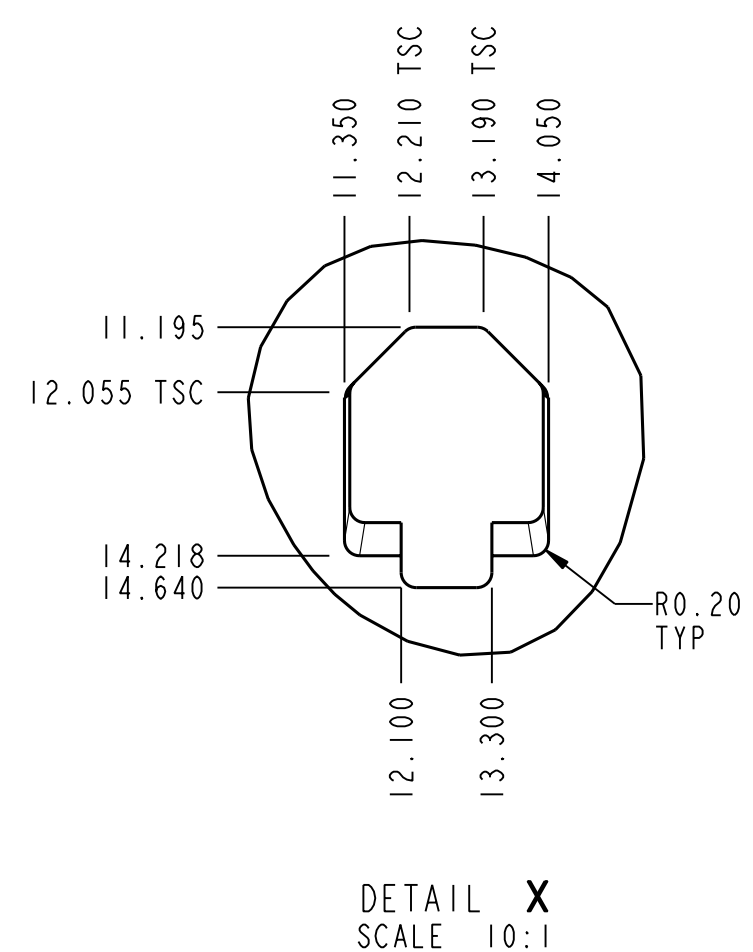
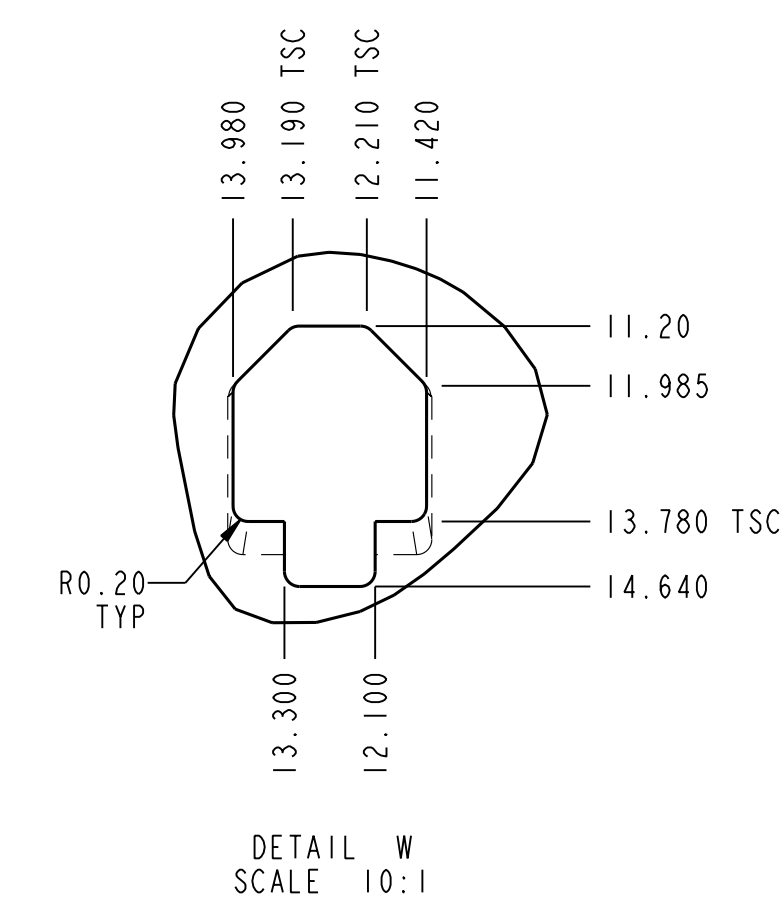
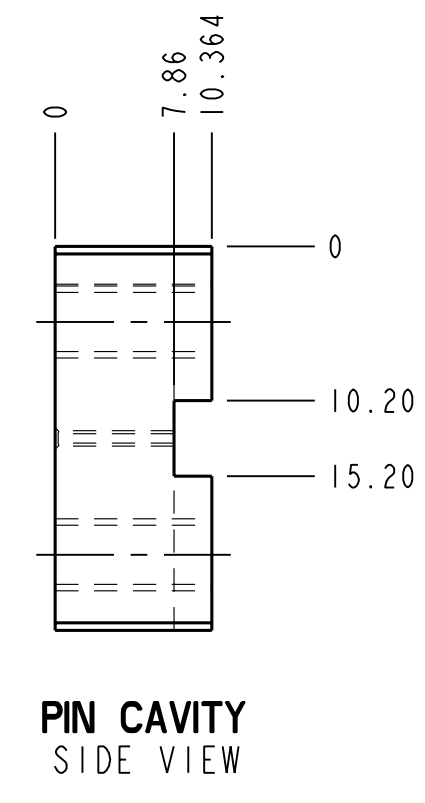
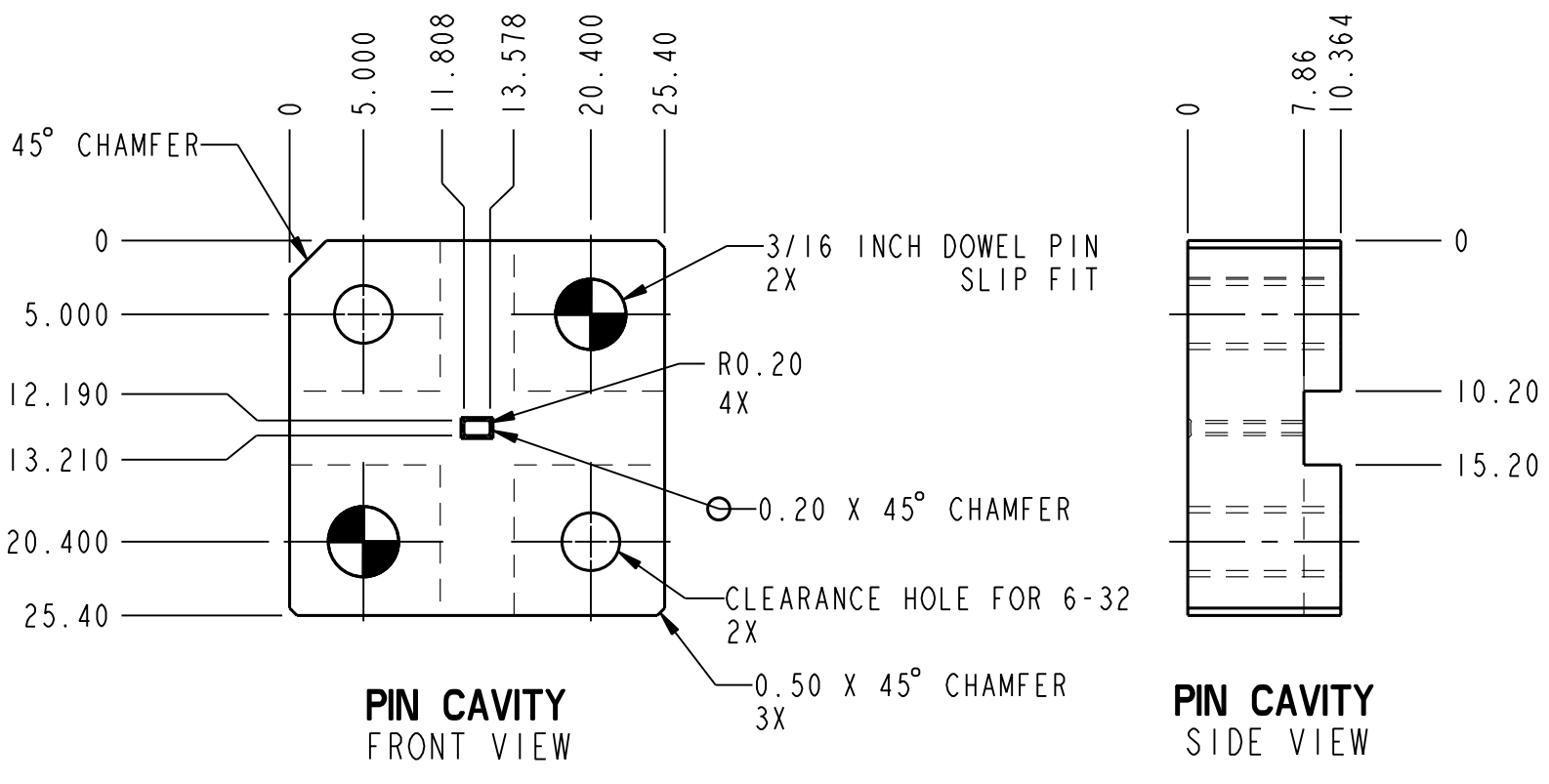
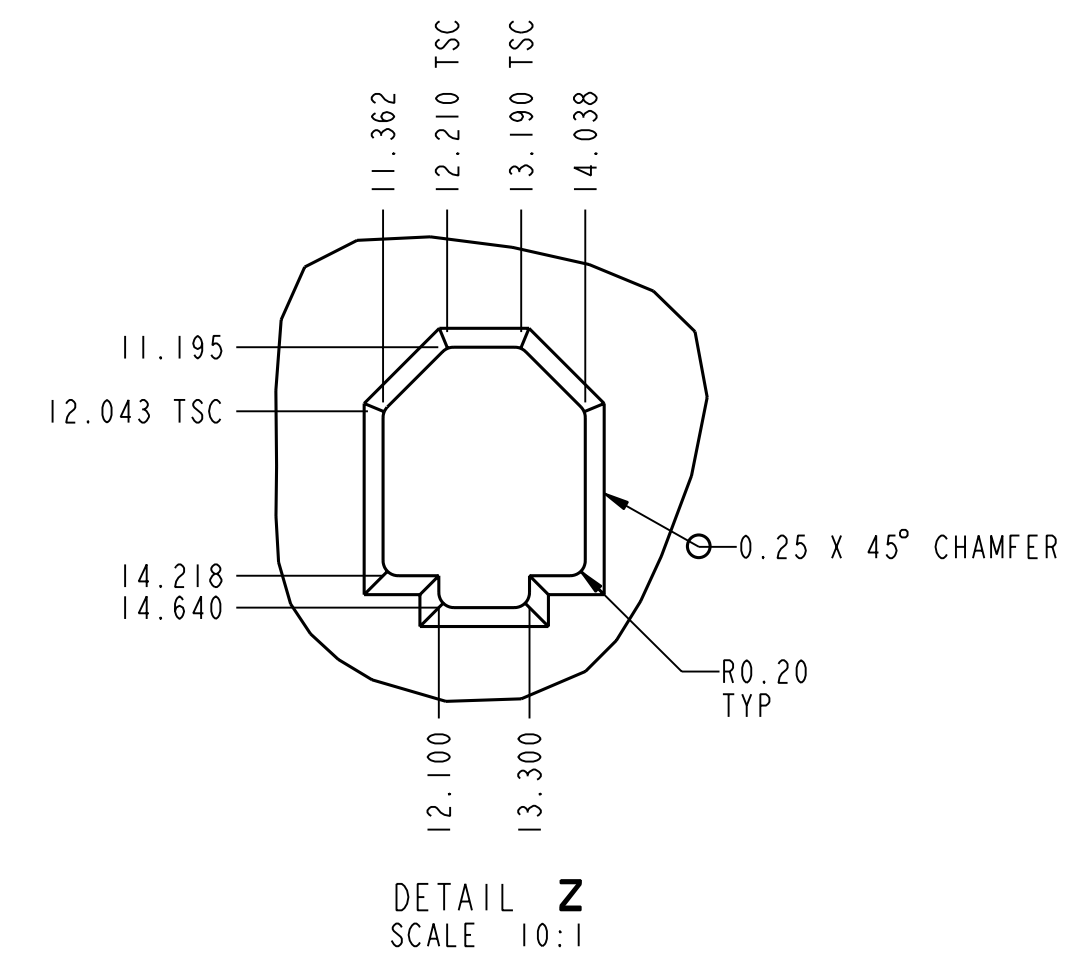
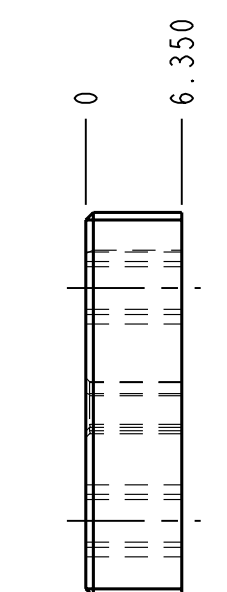
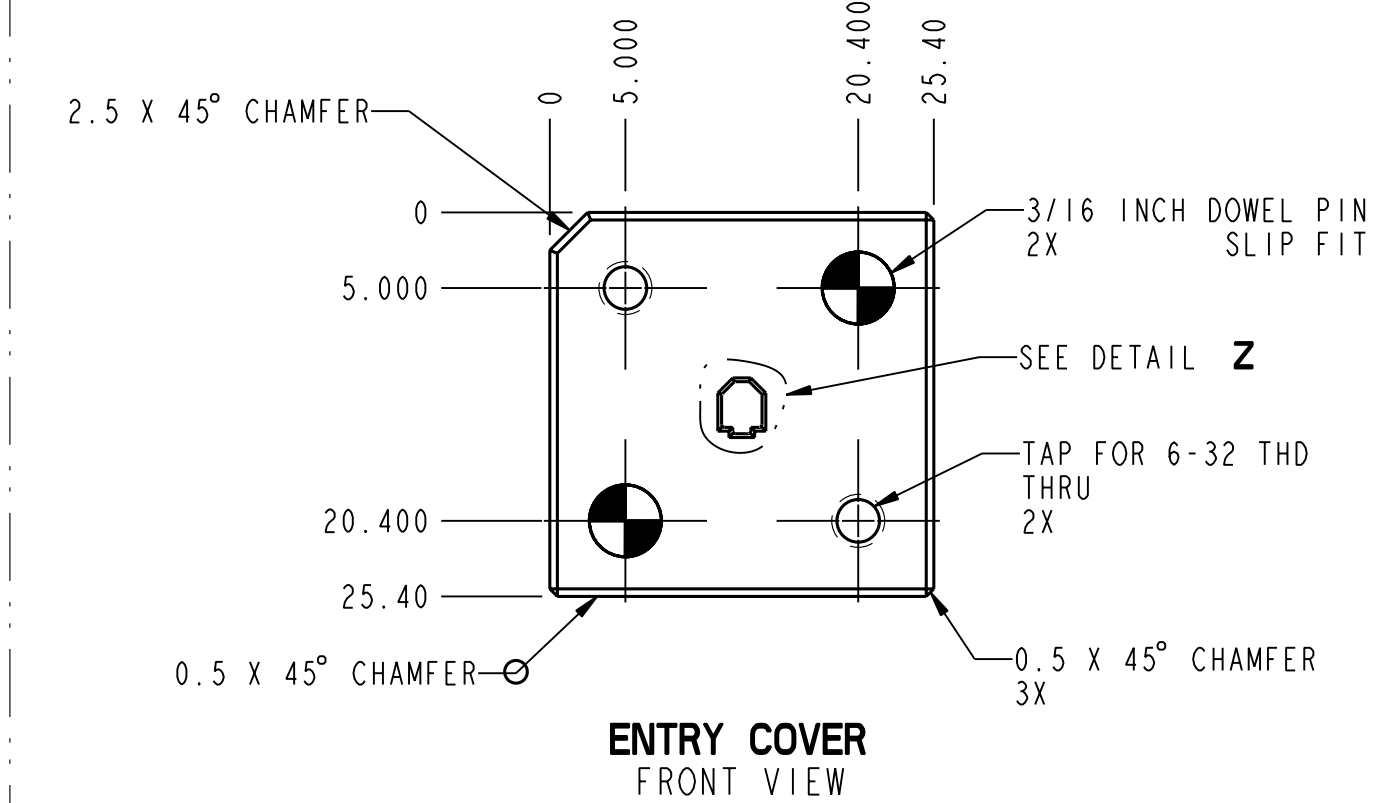
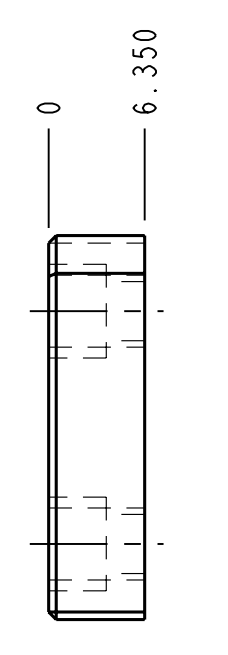
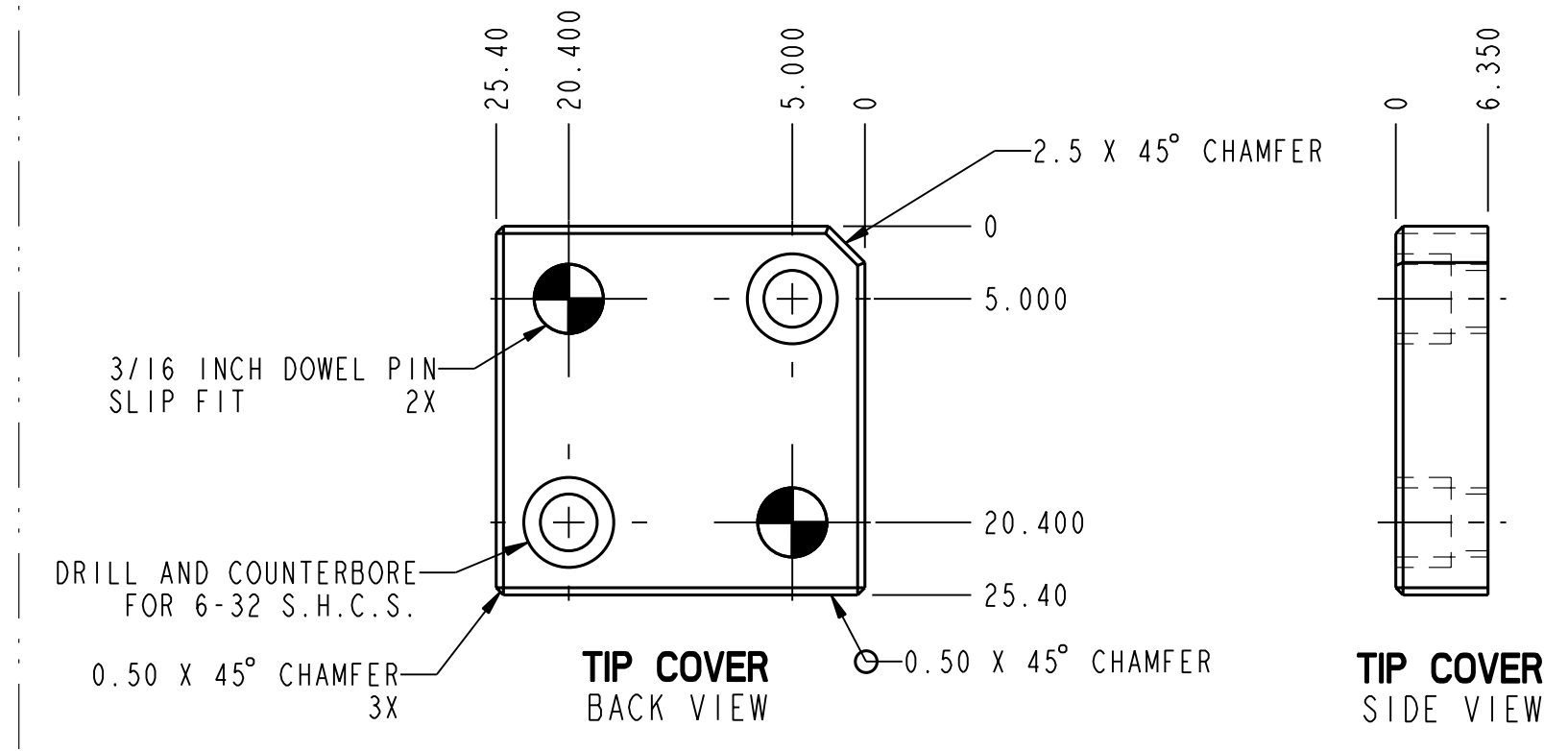
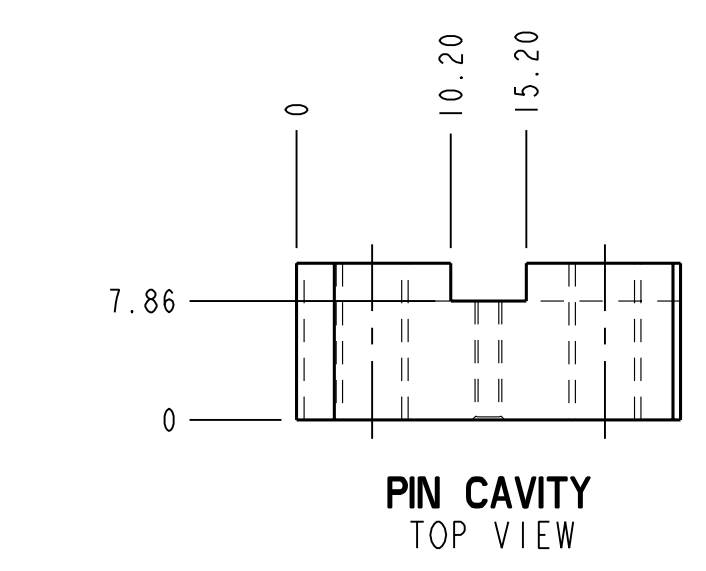

CRIMP TOOLING

- CRIMP REQUIREMENTS:
1. CRIMP STRAIGHTNESS MUST MEET THE REQUIREMENTS AS DESCRIBED ON SHEET 1
 2. THE CRIMPED TERMINAL MUST FIT FREELY INTO THE CHECKING AID AS SHOWN ON THIS PAGE
 3. FOR OTHER MECHANICAL REQUIREMENTS ON CRIMPED TERMINALS REFER TO SAE/JUSCAR-21 (5-13-02) SECTIONS: 4.2 (VISUAL INSPECTION), 4.3 (CROSS SECTION ANALYSIS) AND 4.4 (CONDUCTOR CRIMP PULLOUT FORCE)

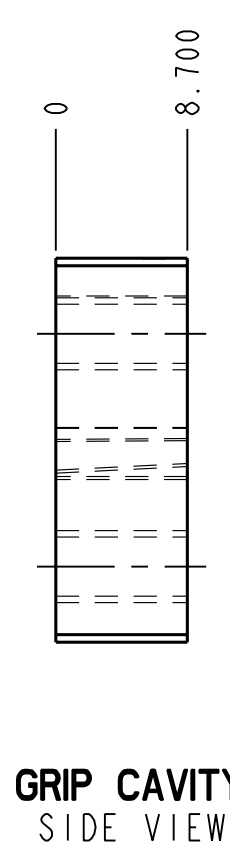
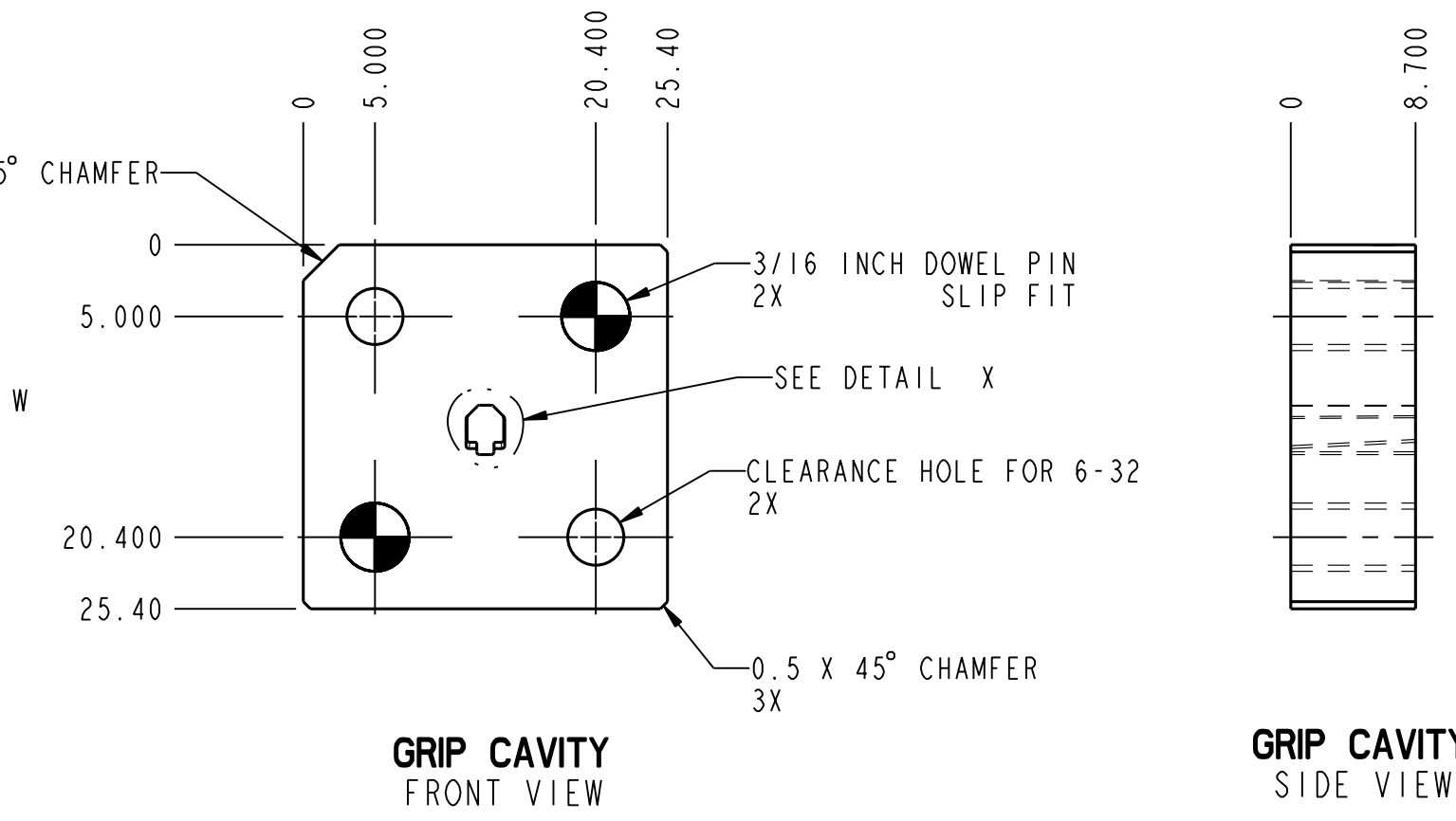
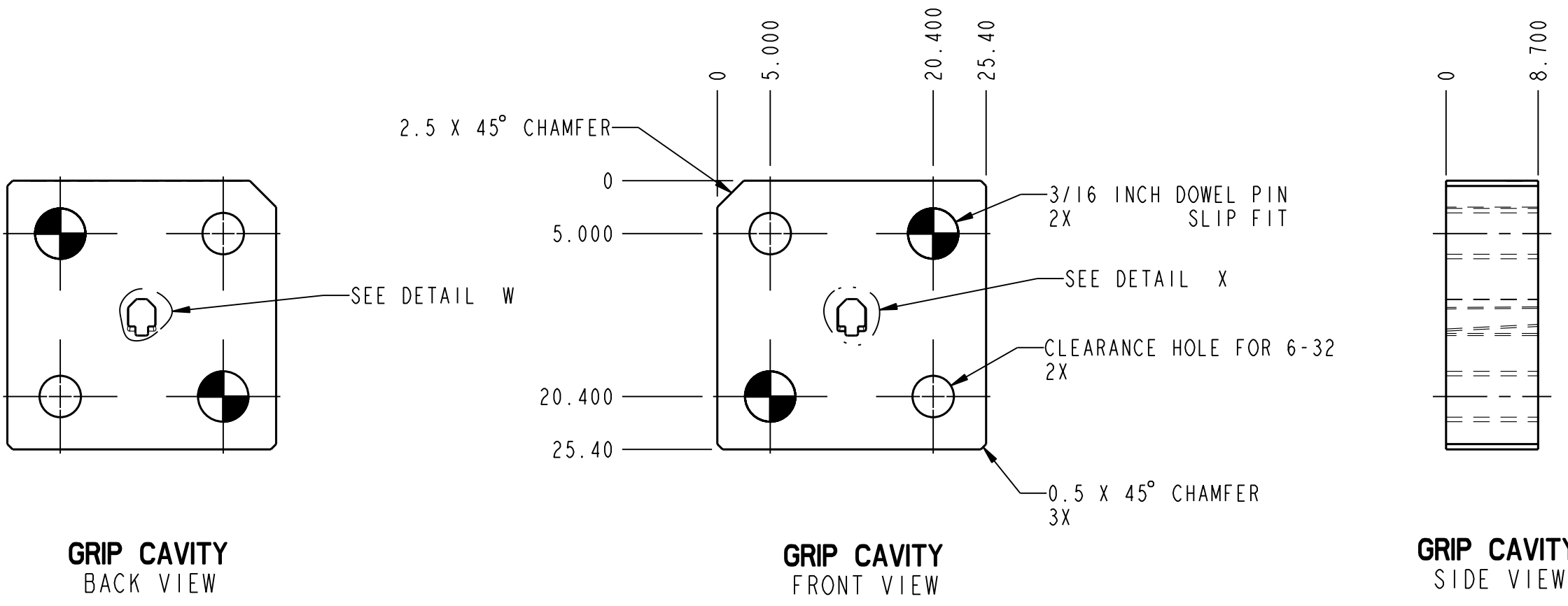

EC NO: UAU2008-0063 DRWN: L.PULLIAM 2007/07/24 CHK: A.DHIR 2007/07/25 APPR: B.MOSER 2007/07/31	QUALITY SYMBOLS	DESCRIPTION	REV	GENERAL TOLERANCES (UNLESS SPECIFIED)		SCALE	DESIGN UNITS	THIRD ANGLE PROJECTION	REVISE ON CAD ONLY
				mm	INCH	2:1	mm		
				4 PLACES	± --	± --	DIMENSION STYLE		TITLE
				3 PLACES	± 0.005	± --	mm		
				2 PLACES	± 0.03	± --	DRAWN BY	DATE	MOLEX INCORPORATED
				1 PLACE	± 0.3	± --	D.G.RIFFITHS	6/15/99	
				ANGULAR		± 3°	CHECKED BY	DATE	DOCUMENT NO. SD-31296-001
							D.G./V.P.	7/28/99	
							APPROVED BY	DATE	
							V.PURUSHOTHAMAN	7/28/99	

THIS DRAWING CONTAINS INFORMATION THAT IS PROPRIETARY TO MOLEX INCORPORATED AND SHOULD NOT BE USED WITHOUT WRITTEN PERMISSION