

TI-PMLK

TI Power Management Lab Kit
Boost Experiment Book



SSQU008A
PMLKBOOSTEVM REV A



Name

University/Company name

Address

Phone

E-mail

Many people have collaborated with me in the realization of the TI-PMLK project, in different times, at different levels, in different ways. My sincerest thanks go to the Texas Instruments University Program Team and to the University of Salerno Power Electronics Laboratory Team.

Nicola Femia

Preface

Felix, qui potuit rerum cognoscere causas...
(Happy, he who could capture the origins of things...)
Publio Virgilio Marone, Mantova 70 B.C. – Brindisi 19 B.C.

Design is an exciting and fascinating art. Power electronics, for its interdisciplinarily nature, is a challenging field where the knowledge of *why* makes all the difference in understanding *how* to achieve design goals. The *will of learning* and the *means for learning* are the two basic ingredients needed to develop the virtuous ability to understand the reality of problems, to select the appropriate techniques and methods to solve them, to make meaningful design decisions and to intelligently evaluate the solutions.

The main purpose of the TI-PMLK collection of Experiment Books is to stimulate the spirit of investigation in students and practicing engineers who are engaged in learning and understanding the design of power supplies. The experiments cover a basic anthology of topics and issues encountered in the design of low power dc-dc non-isolated power supplies, such as power supplies topologies and characteristics, modes of operation, efficiency, control, stability, accuracy, transient response, noise, power magnetics, and more. The experiments can be performed by using the power supply boards of the TI-PMLK suite, which includes low dropout linear regulators and buck, boost and buck-boost switching regulators. The Experiment books are not intended to provide an exhaustive overview of design issues or definitive design hints: rather, it is meant to guide the reader into a multifaceted active learning experience.

All the experiments are based on a logical sequence of steps. They start with the *Case Study* section, which provides the description of the specific property or feature relevant to the power supply board to be used in the experiment, and illustrates the goal and the type of measurement to be done. The *Theory Background* section provides a short summary of concepts, models and equations, supporting the interpretation and understanding of the incoming experimental observations. The *Measurement Setup* section provides the instructions for connecting the instruments needed for the experiments to the board under test. Warnings are provided to prevent main mistakes. The *Test* section provides instructions on how to execute the measurements, and guidelines on how to analyze and understand the results of the measurements. Each test includes an *Answer* section, where the user is required to answer questions and to provide a discussion about the behavior of the board under test, relevant to the specific performance under investigation, based on the observation of the measurements results and on the application of concepts and properties illustrated through the various sections of the experiment. The *Discussion* section provides comments to achieve a better understanding of conceptual and practical correlations among system characteristics and operating performance. The final *Experimental Plots* section illustrates and discusses the results of some sample measurements.

Preface (cont.)

The experiments cover a variety of steady-state, transient and dynamic tests. The tests are mostly based on time domain measurements, while some tests focus on the investigation of dynamic properties that are described through frequency response functions, such as the power supply rejection ratio. This allows a user to conduct a complete experience on the characterization and understanding of power supply issues. Most of the experiments require basic laboratory equipment, including a power supply, some multi-meters, an oscilloscope and a load. Some tests require more sophisticated instrumentation, such as a dynamic source, a dynamic load, and a vector network analyzer, for best measurement.

The boards have been designed to allow the investigation of the influence of physical parameters and operating conditions of a power supply on its own performances. Various combinations of power and control components can be selected. Most of them yield operating conditions that fit good engineering standards. Other ones may lead to operating conditions typically undesired in industry applications, such as instability. Thus, the reader can achieve a sound understanding of such real phenomena.

Suggested combinations of power and control parts are provided for each experiment. The user is invited in some experiments to detect combinations that yield a certain operating condition or behavior. The user can select the setup of jumpers and connectors to generate a great variety of conditions. The book provides recommendations and warnings for safe board operation and for effective measurements. Before performing any experiment, the reader is strongly recommended to read carefully all the warnings and the introductory section of the book, where the specific description of the board is

provided and information on settings and performance are given, including forbidden combinations and special operating conditions. The reader is also strongly invited to read the manufacturers' datasheets of all the parts mounted in the boards, especially the control chips, to improve the knowledge and the understanding of each device.

A good knowledge of the power supplies implemented on the boards, supported by the heuristic observations and the models and methods discussed in the book, help the user to distinguish what can be done from what cannot be done.

The level of detail and completeness of models discussed in the *Theory Background* section vary from experiment to experiment. Sometimes the models include certain specific properties, other times they are simplified or approximated. Achieving familiarity with models is a fundamental learning step: a good power supply designer has to be able to grade the importance of modeling certain properties, at device level as well as at system level, in order to assess if they really provide meaningful and influential information to meet the application requirements. Essential formulas and expressions for the basic analysis of the phenomenon under investigation are mostly introduced without step-by-step theoretical derivations, which are beyond the objectives of the book.

The reader is encouraged to test him(her)self in filling this gap, through an in-depth study of models and methods for the analysis and design of power supplies discussed in the cited references.

Preface (cont.)

The parameters of semiconductor and passive power components mounted on the boards are provided in the book to allow the application of analysis formulas and design equations. All parameters of power components are affected by uncertainty, due to tolerances, ageing and influence factors like temperature, current, voltage and frequency. The values collected in the books have been extracted from the manufacturers' datasheets in certain reference conditions. The power and control components and sub-circuits of integrated circuits controlling the power supplies, which determine modes of operation and performances, are subjected to the influence of temperature, voltage, current and frequency too. As a consequence, the predictions of formulas and equations provided in the book, based on the parameters of power and control devices, can show different levels of agreement with respect to the results of experimental measurements.

The user is strongly encouraged to read the references provided in the book, to analyze the characteristics and the behavior of integrated circuits and power components of the boards, and to verify if different values of the parameters of components can be used to achieve a better compliance between the results of formulas and the results

of experimental measurements. The investigation of real device characteristics and of their influence on overall performance of a power supply is a fundamental component of designers' work.

The ultimate intention of this book is to accompany the reader through an active experience, made of observations, application of physics and mathematics, reality investigation and system level reasoning. That is engineering insight. The Author hopes the reader may fully enjoy this book and the pleasure of being a design engineer, a creative and autonomous thinker, able to acquire and re-elaborate the knowledge to win ever new design challenges.

Know why, know how!

Nicola Femia



Nicola Femia is Professor at the University of Salerno, Italy, where he teaches Power Electronics and Energetic Intelligence, in the Electronic Engineering and Computer Engineering Master Degree Programs. He leads the Power Electronics and Renewable Sources Laboratory. Over the past 25 years, he has promoted and directed worldwide university and industry research activities and education programs on power electronics, photovoltaic systems, and power design. He has been Visiting Professor at the Electrical Engineering Department of the Stanford University, Stanford, CA, where he taught Power Electronics Control and Energy Aware Design.

e-mail: femia@unisa.it;

web: www.unisa.it/docenti/nicolafemia/index

Table of Contents

Preface	7
Instrumentation needed for Experiments.	13
TI-PMLK BOOST TPS55340 description	
• Schematic	16
• Bill of Materials	17
• Board	18
• Connectors, Jumpers and Test Pins	19
TI-PMLK BOOST LM5122 description	
• Schematic	20
• Bill of Materials	21
• Board	22
• Connectors, Jumpers and Test Pins	23
Notes, Warnings and Recommendations.	24
Experiment 1	
<i>Impact of the operating conditions on the operation mode.</i>	25
Experiment 2	
<i>Impact of operation mode on the efficiency</i>	37

Experiment 3	
<i>Impact of the operating conditions on the dynamic response.</i>	49
Experiment 4	
<i>Impact of operating conditions and inductor characteristics on current limiting.</i>	61
Experiment 5	
<i>Impact of current slope compensation and voltage feedback compensation on line transient respons</i>	77
Experiment 6	
<i>Impact of current slope compensation and voltage feedback compensation on load transient response</i>	89
Appendix A	
References	101
Appendix B	
Manufacturers websites.	102



Instrumentation needed for experiments

The instrumentation recommended for the execution of the experiments of this book is comprised of:

- *DC power supply 0-50V/4A with dynamic voltage mode capability*
- *DC electronic load 20V/10A with dynamic current mode capability*
- *4 digital multimeters with 4½ digit resolution*
- *250MHz 4-channels Digital Oscilloscope + 2 current probes 20A/50MHz*

The instrumentation used in the lab tests corresponding to the Experimental Plot samples shown in the book is comprised of:

- *TTI EX354RT Power Supply 0-70V, 4A (used in the experiments where the board under test had to be fed by a constant DC voltage source)*
- *Keithley 2420 SourceMeter, 63V, 3.15A (used in the experiments where the board under test had to be fed by a dynamic DC voltage source)*
- *Sorensen Electronic Load SLM-4 mainframe + SLM series electronic load modules 60V/60A*
- *4 Hewlett-Packard 34401A multimeters*
- *LeCroy WaveRunner 44Xi 400MHz 4-channels Digital Oscilloscope, with 2 Tektronix TCP 305 50A current probe + Tektronix TCP A300 amplifier*



TI-PMLK-Boost

The TI-PMLK BOOST is an experimental power supply board based on the two wide input range TPS55340 and LM5122 DC-DC boost regulators



TI-PMLK TPS55340 Schematic

The TI-PMLK TPS55340 section of the board accepts input voltages in between 5V and 12V, while regulates the output voltage at 24V with maximum load current 1.9A.

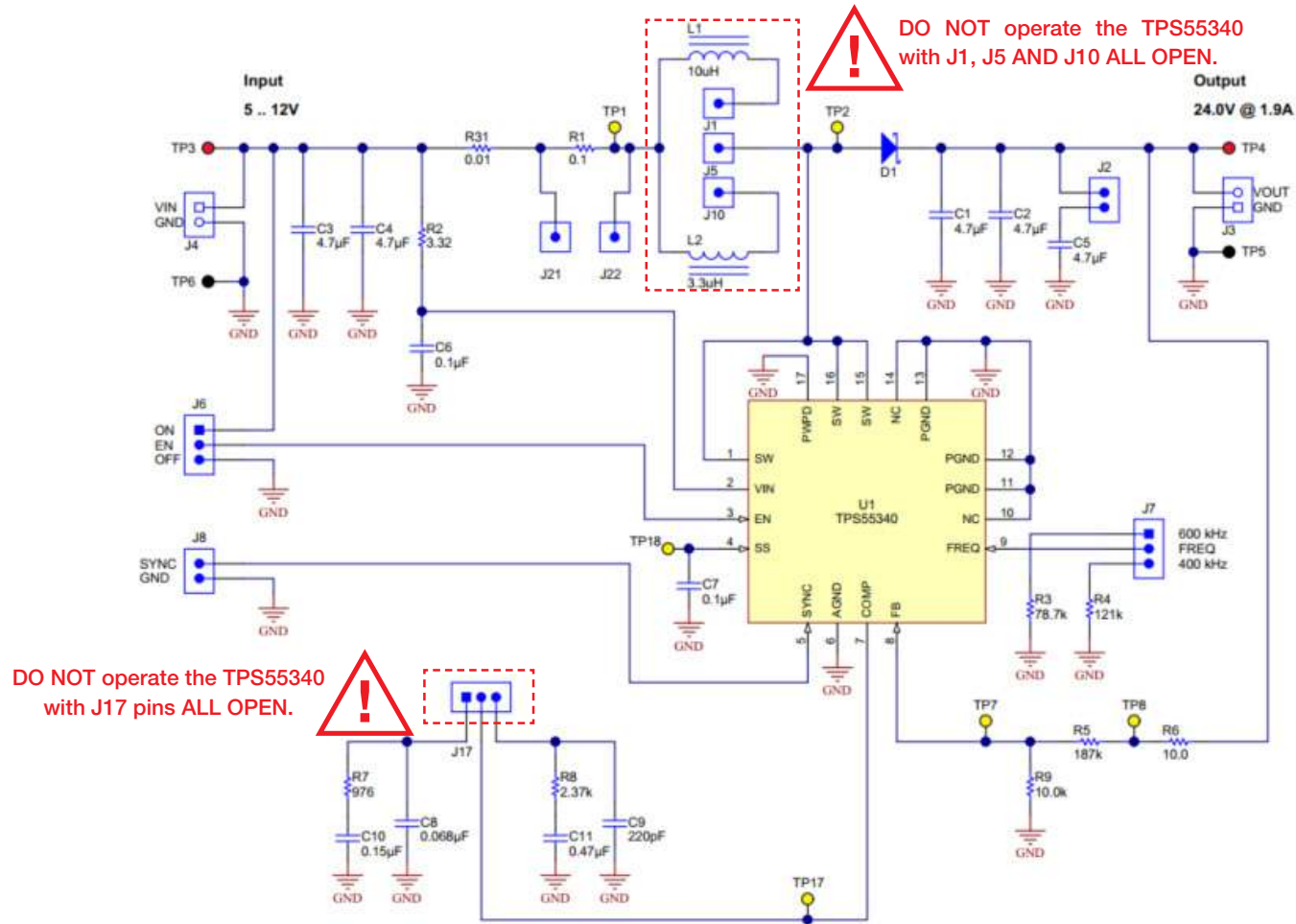

Figure 1. Circuit schematic of TI-PMLK TPS55340 boost regulator



TI-PMLK TPS55340 Bill of Materials

Designator	Description	Manufacturer	Part Number
C ₁ , C ₂ , C ₃ , C ₄ , C ₅	4.7μF Capacitor 50V X7R 10% 1206	Taiyo Yuden	UMK316AB7475KL-T
C ₆ , C ₇	100nF Capacitor 50V X7R 10% 0805	Kemet	C0805C104K5RACTU
C ₈	68nF Capacitor 100V X7R 10% 0805	Kemet	C0805C683K1RACTU
C ₉	220pF Capacitor 50V C0G/NP0 5% 0805	Kemet	C0805C221J5GACTU
C ₁₀	150nF Capacitor 50V X7R 10% 0805	Kemet	C0805C154K5RACTU
C ₁₁	470nF Capacitor 50V X7R 10% 0805	MuRata	GRM21BR71H474KA88L
D ₁	Diode, Schottky, 40V, 5A SMC	Diodes Incorporated	B540C-13-F
L ₁	10μH Inductor Drum Core, Ferrite, 5.7A, 0.02Ω 12.3x12.3mm SMD	Coilcraft	MSS1278-103MLB
L ₂	3.3μH Inductor Drum Core, Ferrite, 6.3A, 0.02Ω 12.3x12.3mm SMD	Coilcraft	MSS1246T-332MLB
R ₁	0.1Ω Resistor 1W 1% 2512	Panasonic Electronic Components	ERJ-L1WKF10CU
R ₂	3.32Ω Resistor 1% 0.125W 0805	Vishay-Dale	CRCW08053R32FKEA
R ₃	78.7kΩ Resistor 1% 0.125W 0805	Vishay-Dale	CRCW080578K7FKEA
R ₄	121kΩ 1% Resistor 0.125W 0805	Vishay-Dale	CRCW0805121KFKEA
R ₅	187kΩ 1% Resistor 0.125W 0805	Vishay-Dale	CRCW0805187KFKEA
R ₆	10Ω Resistor 0.125W 0805	Vishay-Dale	CRCW080510R0FKEA
R ₇	976Ω Resistor 1% 0.125W 0805	Vishay-Dale	CRCW0805976RFKEA
R ₈	2.37kΩ Resistor 1% 0.125W 0805	Vishay-Dale	CRCW08052K37FKEA
R ₉	10kΩ Resistor 1% 0.125W 0805	Vishay-Dale	CRCW080510K0FKEA
R ₃₁	0.01Ω Resistor 3W 1% 15.2x1.0x25.4	TT Electronics/IRC	OAR3R010FLF
U ₁	Integrated 5-A 40-V Wide Input Range Boost/SEPIC/Flyback DC-DC Regulator, RTE0016C	Texas Instruments	TPS55340RTE

(use the part numbers of components to retrieve, through the manufacturers websites listed in the references, details about parameters and data that are used in the formulae provided for calculations in each experiment)



TI-PMLK TPS55340 Board

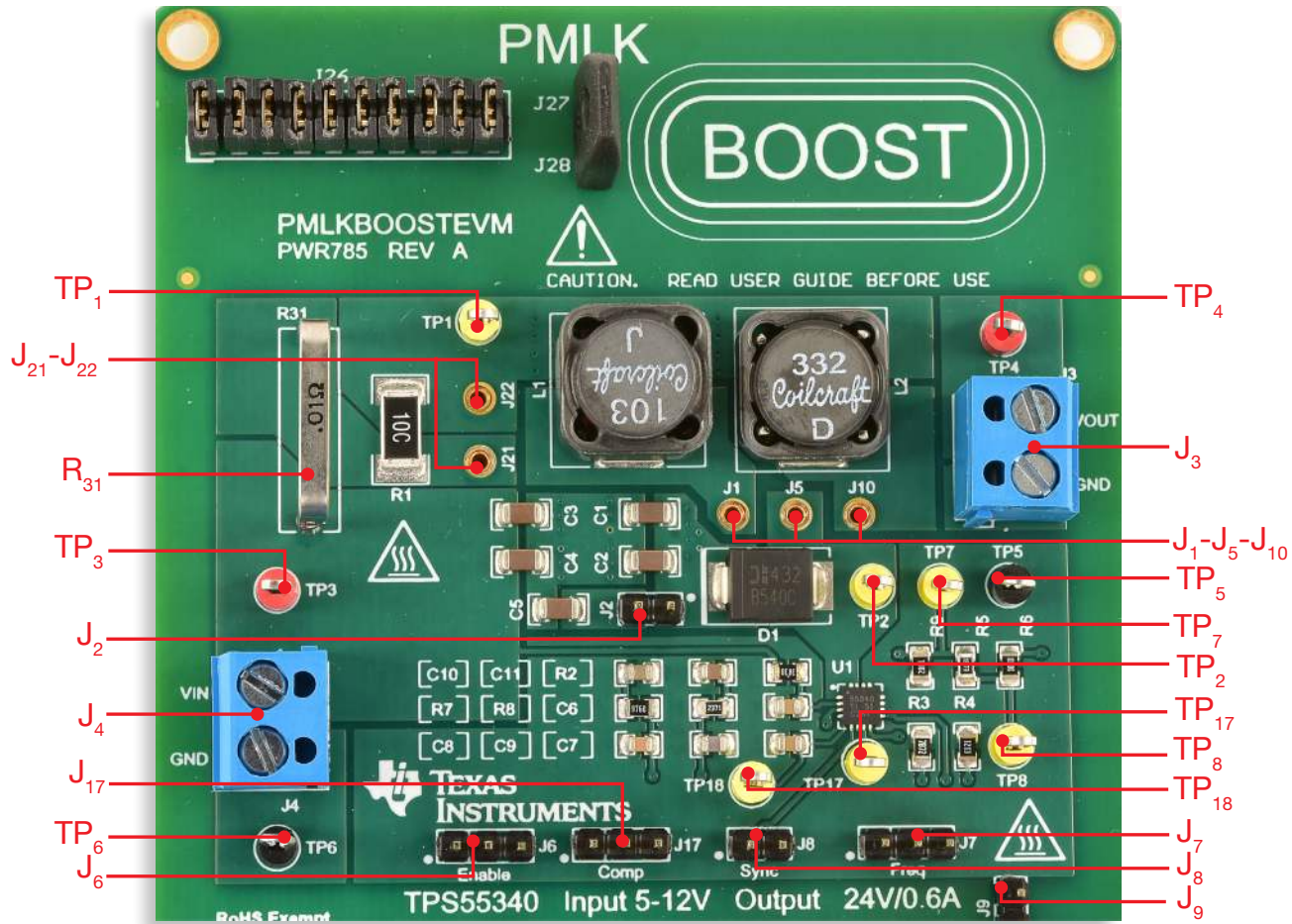

Figure 2. Plain view of TI-PMLK TPS55340 BOOST regulator board



TI-PMLK TPS55340 Connectors, Jumpers and Test Pins

Descriptors and functions for Connectors, Jumpers and Test Pins

Connectors

- J₃** - output voltage
- J₄** - input voltage

Jumpers

- J₂** - connects C₅ (4.7μF) output capacitor
- J₆** - connects to external enable signal
- J₇** - switching frequency setup:
shorted left → f_s = 600kHz
shorted right → f_s = 400kHz
- J₈** - connects to external synchronization signal
- J₁₇** - error amplifier gain setup:
shorted left → connects parts R₇, C₁₀, C₈
(lower cross-over frequency with L=10μH)
shorted right → connects parts R₈, C₉, C₁₁
(higher cross-over frequency with L=10μH)
- J₉** - connects grounds of TPS55340 and LM5122 board sections

High current jumpers

- J₁-J₅** - connects inductor L₁ (ferrite core, 10μH)
- J₅-J₁₀** - connects inductor L₂ (ferrite core, 3.3μH)
- J₂₁-J₂₂** - by-passes the loss emulation resistor R₁

Test pins

- TP₃** - positive pole of input voltage
- TP₆** - ground pole of input voltage
- TP₄** - positive pole of output voltage
- TP₅** - ground pole of output voltage
- TP₁** - can be used together with **TP₂** to sense the inductor voltage, and together with **TP₃** to sense the voltage across the current shunt resistor R₃₁ and the loss emulation resistor R₁ (when **J₂₁-J₂₂** are open). The shunt resistor R₃₁ allows to hang a current probe for inductor current measurement.
- TP₂** - switching node
- TP₇** - feedback voltage
- TP₈** - connection pin for loop gain measurements, can be used together with **TP₄** to inject the ac stimulus into the 10Ω resistor R₆
- TP₁₇** - control voltage
- TP₁₈** - soft-start voltage

Voltage and Current Measurements

- hang a current probe to the shunt resistor R₃₁ to measure the inductor current
- use **TP₃** and **TP₆** to measure the input voltage
- use **TP₄** and **TP₅** to measure the output voltage
- use **TP₂** and **TP₅** to measure the switching node voltage
- use **TP₁₇** and **TP₅** to measure the feedback voltage
- hang a current probe to one of the external power wires connected to **J₄** to measure the input current
- hang a current probe to one of the external power wires connected to **J₃** to measure the load current

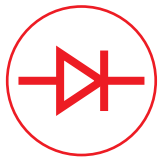

TI-PMLK LM5122 Schematic

The TI-PMLK LM5122 section of the board accepts input voltages in between 9V and 20V, while regulates the output voltage at 24V with maximum load current 2A.

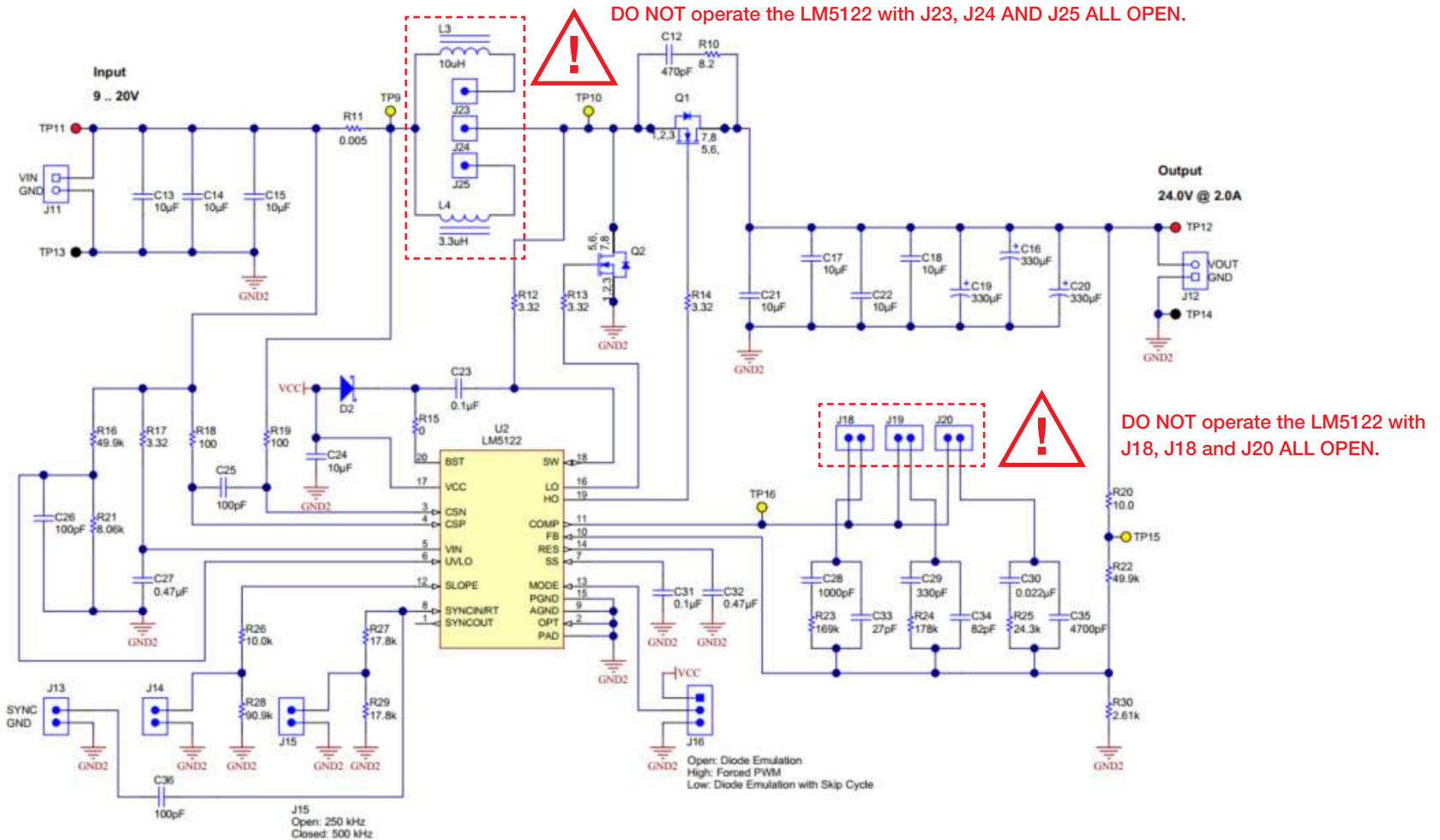

Figure 3. Circuit schematic of TI-PMLK LM5122 BOOST regulator



TI-PMLK LM5122 Bill of Materials

Designator	Description	Manufacturer	Part Number
C ₁₂	470pF ceramic capacitor 100V NP0 5% C0G/NP0 0805	MuRata	GRM2165C2A471JA01D
C ₁₃ , C ₁₄ , C ₁₅ , C ₁₇ , C ₁₈ , C ₂₁ , C ₂₂	10μF ceramic capacitor 50V X7R 20% 1210	TDK	C3225X7R1H106M250AC
C ₁₆ , C ₁₉ , C ₂₀	330μF electrolytic capacitor 35V 20% 0.06Ω	Panasonic Electronic Components	EEE-FP1V331AP
C ₂₃ , C ₃₁	100nF ceramic capacitor 50V X7R 10% 0805	Kemet	C0805C104K5RACTU
C ₂₄	10μF ceramic capacitor 16V X5R 10% 0805	Taiyo Yuden	EMK212BJ106KG-T
C ₂₅	10nF ceramic capacitor 50V C0G/NP0 5% 0805	MuRata	GQM2195C1H101JB01D
C ₂₆ , C ₃₆	100pF ceramic capacitor 50V C0G/NP0 5% 0805	MuRata	GQM2195C1H101JB01D
C ₂₇ , C ₃₂	470nF ceramic capacitor 50V X7R 10% 0805	MuRata	GRM21BR71H474KA88L
C ₂₈	1nF ceramic capacitor 50V C0G/NP0 5% 0805	MuRata	GRM2165C1H102JA01D
C ₂₉	330pF ceramic capacitor 50V C0G/NP0 5% 0805	MuRata	GRM2165C1H331JA01D
C ₃₀	22nF ceramic capacitor 50V X7R 5% 0805	MuRata	GRM216R71H223KA01D
C ₃₃	27pF ceramic capacitor 50V C0G/NP0 5% 0805	MuRata	GQM2195C1H270JB01D
C ₃₄	82pF ceramic capacitor 50V C0G/NP0 5% 0805	MuRata	GQM2195C1H820JB01D
C ₃₅	4.7nF ceramic capacitor 50V C0G/NP0 5% 0805	Murata	GRM2165C1H472JA01D
D ₂	Diode, Schottky, 60V, 1A SOD-123	Rohm Semiconductor	RB160M-60TR
L ₃	10μH Inductor Shielded, Composite, 2.6A, 0.057Ω SMD	Coilcraft	XAL7030-103
L ₄	3.3μH Inductor Shielded, Composite, 10A, 0.0195Ω SMD	Coilcraft	XAL7030-332MEB
Q ₁ , Q ₂	MOSFET N-CH 60V, 50A, SON 5x6mm	Texas Instruments	CSD18537NQ5A
R ₁₀	8.2Ω Resistor 5% 0.75W 2010	Vishay Dale	CRCW20108R20JNEF
R ₁₁	0.005Ω Resistor 1% 3W	TT Electronics/IRC	OAR3R005FLF
R ₁₂ , R ₁₃ , R ₁₄ , R ₁₇	3.32Ω Resistor 1% 0.125W 0805	Vishay Dale	CRCW08053R32FKEA
R ₁₅	0Ω Resistor 5% 0.125W 0805	Vishay Dale	CRCW08050000Z0EA
R ₁₆ , R ₂₂	49.9kΩ Resistor 1% 0.125W 0805	Vishay Dale	CRCW080549K9FKEA
R ₁₈ , R ₁₉	100Ω Resistor 1% 0.125W 0805	Vishay Dale	CRCW0805100RFKEA
R ₂₀	10Ω Resistor 1% 0.125W 0805	Vishay Dale	CRCW080510R0FKEA
R ₂₁	8.06kΩ Resistor 1% 0.125W 0805	Vishay Dale	CRCW08058K06FKEA
R ₂₃	169kΩ Resistor 1% 0.125W 0805	Vishay Dale	CRCW0805169KFKEA
R ₂₄	178kΩ Resistor 1% 0.125W 0805	Vishay Dale	CRCW0805178KFKEA
R ₂₅	24.3kΩ Resistor 1% 0.125W 0805	Vishay Dale	CRCW080524K3FKEA
R ₂₆	10kΩ Resistor 1% 0.125W 0805	Vishay Dale	CRCW080510K0FKEA
R ₂₇ , R ₂₉	17.8kΩ Resistor 1% 0.125W 0805	Vishay Dale	CRCW080517K8FKEA
R ₂₈	90.9kΩ Resistor 1% 0.125W 0805	Vishay Dale	CRCW080590K9FKEA
R ₃₀	2.61kΩ Resistor 1% 0.125W 0805	Vishay Dale	CRCW08052K61FKEA
U ₂	Wide Input Synchronous Boost Controller with Multiple Phase Capability, PWP0020A	Texas Instruments	LM5122MH/NOPB

(use the part numbers of components to retrieve, through the manufacturers websites listed in the references, details about parameters and data that are used in the formulae provided for calculations in each experiment)



TI-PMLK LM5122 Board

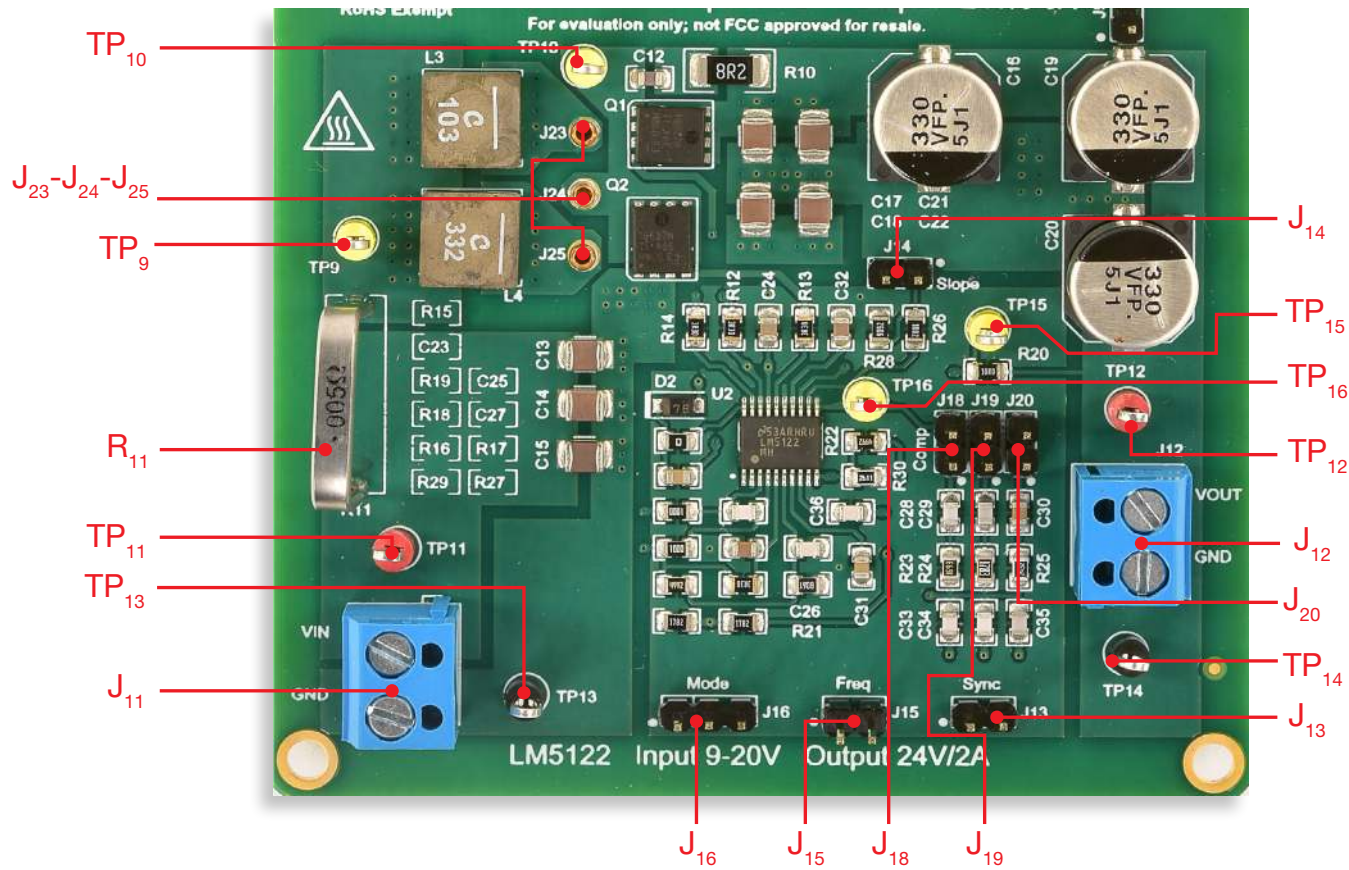

Figure 4. Plain view of TI-PMLK LM5122 BOOST regulator board



TI-PMMLK LM5122 Connectors, Jumpers and Test Pins

Descriptors and functions for Connectors, Jumpers and Test Pins

Connectors

- J₁₁** - input voltage
- J₁₂** - output voltage

Jumpers

- J₁₃** - connects to external synchronization signal
- J₁₄** - compensation slope setup:
open → lower slope
shorted → higher slope
- J₁₅** - switching frequency setup:
shorted → $f_s = 500\text{kHz}$
open → $f_s = 250\text{kHz}$
- J₁₆** - diode emulation setup:
open → diode emulation
shorted left → forced PWM
shorted right → diode emulation with skip cycle
- J₁₈** - error amplifier gain setup:
connects parts R_{23} , C_{28} , C_{33} (high cross-over frequency with $L=10\mu\text{H}$, and high slope compensation ramp)
- J₁₉** - error amplifier gain setup:
connects parts R_{24} , C_{29} , C_{34} (higher cross-over frequency with $L=10\mu\text{H}$, and low slope compensation ramp)
- J₂₀** - error amplifier gain setup:
connects parts R_{25} , C_{30} , C_{33} (lower cross-over frequency with $L=10\mu\text{H}$, and low slope compensation ramp)
- J₉** - connects grounds of LM5122 and TPS55340 sections

High current jumpers

- J₂₃-J₂₄** - connects inductor L_3 (powdered core, $10\mu\text{H}$)
- J₂₄-J₂₅** - connects inductor L_4 (powdered core, $3.3\mu\text{H}$)

Test pins

- TP₁₁** - positive pole of input voltage
- TP₁₃** - ground pole of input voltage
- TP₁₂** - positive pole of output voltage
- TP₁₄** - ground pole of output voltage
- TP₉** - can used together with **TP₁₀** to sense the inductor voltage, and together with **TP₁₁** to sense the voltage across the current shunt R_{11} . The shunt resistor R_{11} allows to hang a current probe for inductor current measurement.
- TP₁₀** - switching node
- TP₁₅** - connection pin for loop gain measurements, can be used together with **TP₁₂** to inject the ac stimulus into the 10Ω resistor R_{20}
- TP₁₆** - control voltage

Voltage and Current Measurements

- hang a current probe to the shunt resistor R_{11} to measure the inductor current
- use **TP₁₁** and **TP₁₃** to measure the input voltage
- use **TP₁₂** and **TP₁₄** to measure the output voltage
- use **TP₁₀** and **TP₁₃** to measure the switching node voltage
- use **TP₁₆** and **TP₁₄** to measure the control voltage
- hang a current probe to one of the external power wires connected to **J₁₁** to measure the input current
- hang a current probe to one of the external power wires connected to **J₁₂** to measure the load current



Notes, Warnings and Recommendations

NOTES

TPS55340 BOARD:

- The compensation set with J_{17} shorted left side is tailored to achieve about 45° phase margin at 1.5kHz cross-over frequency with inductance $L=10\mu\text{H}$ (J_1 - J_5 shorted), at minimum input voltage and maximum load current
- The compensation set with J_{17} shorted right side is tailored to achieve about 45° phase margin at 6.5kHz cross-over frequency with inductance $L=10\mu\text{H}$ (J_1 - J_5 shorted), at minimum input voltage and maximum load current

LM5122 BOARD:

- The compensation set with J_{18} shorted, J_{19} open and J_{20} open is tailored to achieve about 52° phase margin at 6kHz cross-over frequency with inductance $L=10\mu\text{H}$ (J_1 - J_5 shorted), and slope compensation resistance $R_{\text{sc}}=10\text{k}\Omega$ (J_{14} shorted), at minimum input voltage and maximum load current
- The compensation set with J_{19} shorted, J_{18} open and J_{20} open is tailored to achieve about 52° phase margin at 6kHz cross-over frequency with inductance $L=10\mu\text{H}$ (J_1 - J_5 shorted), and slope compensation resistance $R_{\text{sc}}=100\text{k}\Omega$ (J_{14} open), at minimum input voltage and maximum load current
- The compensation set with J_{20} shorted, J_{18} open and J_{19} open is tailored to achieve about 52° phase margin at 600Hz cross-over frequency with inductance $L=10\mu\text{H}$ (J_1 - J_5 shorted), and slope compensation resistance $R_{\text{sc}}=100\text{k}\Omega$ (J_{14} open), at minimum input voltage and maximum load current
- The resistor R_{11} senses the inductor current and generates a voltage signal which is used by the LM5122 current mode controller. The resistor R_{11} has a parasitic inductance of about 30nH, which determines the action of the current limit if the 3.3μH powdered core inductor L_4 is connected and the load current exceeds about 15mA. The effects of parasitic inductances on current sensing is current mode control discusses in *Experiment 3*.

WARNINGS AND RECOMMENDATIONS

GENERAL

- 1) **DO NOT** exceed input and output voltage and current ratings
- 2) If the board is terminated in the output onto an electronic load in constant current mode, the sequence to follow is:
 - a) at the turn on: turn on the input power supply then turn on the load
 - b) at the turn off: turn off the load then turn off the input power supply
- 3) Whatever change in the setup of jumpers has to be done, the board has to be shut down first.

TPS55340 BOOST REGULATOR

- 1) **DO NOT** operate the regulator with J_{17} **OPEN ON BOTH SIDES**
- 2) **DO NOT** operate the regulator with both J_1 **AND** J_5 **AND** J_{10} **ALL OPEN**

LM5122 BOOST REGULATOR

- 1) **DO NOT** operate the regulator with J_{18} **AND** J_{19} **AND** J_{20} **ALL OPEN**
- 2) **DO NOT** operate the regulator with J_{18} **AND** J_{19} **AND** J_{20} **ALL SHORTED**
- 3) **DO NOT** operate the regulator with J_{18} **AND** J_{19} **SHORTED**
- 4) **DO NOT** operate the regulator with J_{19} **AND** J_{20} **SHORTED**
- 5) **DO NOT** operate the regulator with J_{18} **AND** J_{20} **SHORTED**
- 6) **DO NOT** operate the regulator with both J_{23} **AND** J_{24} **AND** J_{25} **ALL OPEN**
- 7) **DO NOT** operate the regulator with J_{24} - J_{25} **SHORTED**, which connects inductor L_4 (powdered core, 3.3μH), until you perform *Experiment 3*

Experiment 1

The goal of this experiment is to analyze the influence of input voltage, load current and switching frequency on the continuous mode operation and discontinuous mode operation of the boost converter. The LM5122 BOOST regulator is used for this experiment.



Case Study

The goal of this experiment is to analyze the impact of input voltage, load current and switching frequency on the continuous/discontinuous operation of the boost converter, and to analyze how the duty-cycle changes with the operating conditions and with the operation mode.

The TI-PMLK LM5122 boost regulator operates with $V_{in}=[9,20]V^{(1)}$, while regulating the output voltage at the nominal value $V_{out}=24V$, $I_{out}=[0,2]A$. Fig.1 shows the simplified circuit schematic of the regulator. The LM5122 boost regulator can operate in two different modes, depending on the setup of jumper J_{16} . When J_{16} is open, the Q_1 gate drive is disabled so that the Q_1 channel is permanently open and the LM5122 operates in **Diode Emulation Mode (DEM)**, as the conduction from the inductor to the output is realized by means of the body diode of the MOSFET Q_1 . In these conditions the boost converter can operate in **Discontinuous Conduction Mode (DCM)** at low load. When J_{16} is shorted between the LM5122 MODE PIN and the V_{CC} voltage, the Q_1 gate drive is enabled so that Q_1 works as a synchronous switch and the LM5122 operates in **Synchronous Operation Mode (SOM)**⁽²⁾. In these conditions the boost converter operates always in **Continuous Conduction Mode (CCM)**, for all values of current delivered to the load. For given input voltage V_{in} and load current I_{out} , the relation between the input voltage V_{in} , the output voltage V_{out} and the duty-cycle D is different between DEM and SOM setup.

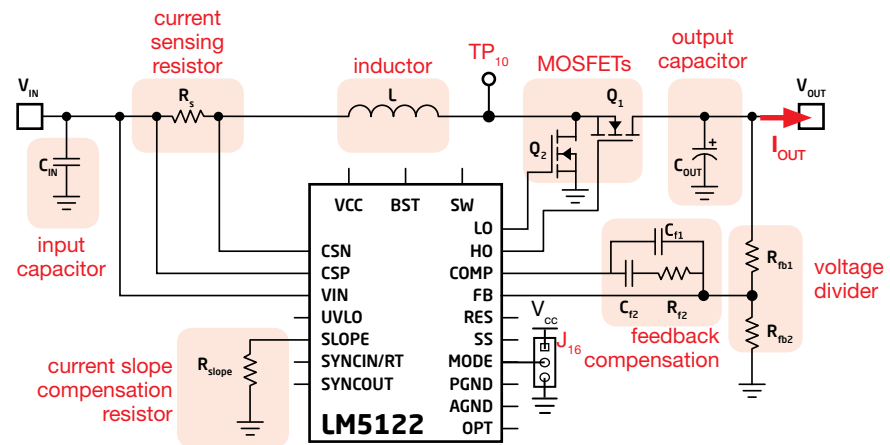

Figure 1. Simplified schematic of the LM5122 BOOST regulator

⁽¹⁾ Restricted range adopted for this educational board, compared to the 4.5V to 65V full range of LM5122 [4]

⁽²⁾ Also defined Forced PWM Mode [4]

Test#1. We investigate the operation of the boost converter in CCM and in DCM, and we measure the duty-cycle while varying the input voltage and the load current. The DCM is detected by analyzing the inductor current waveform flowing through the current sensing resistor R_s (R_{11} in the board) and the duty-cycle is measured by analyzing the switching node voltage at TEST PIN TP_{10} . The test is realized for given input voltage and load current conditions and with different setup of jumper J_{16} , which sets the DEM or SOM. The goal is to analyze how the DCM influences the duty-cycle of the boost converter for given input voltage and load current.

Test#2. We analyze the impact of the switching frequency on the operation of the boost converter with DEM setup, while varying the input voltage. The test is realized for three values of the load current, and for two values of the switching frequency, which is fixed by the setup of jumper J_{15} . The goal is to see the effect of switching frequency on the input voltage operation range during DCM, and to see the correlation between the theoretical formula that predicts the DCM operation neglecting the power losses.



Theory Background

The boost converter characteristics with DEM and SOM setup can be analyzed by means of the formulae provided in this section (see [1][2] for more details on boost topology operation and CCM/DCM modeling; see [4] for more details on LM5122 operation and features).

Load current above the DCM threshold

The load current I_{out} influences the CCM/DCM operation of the boost converter. The threshold value which can determine a possible change in the operation mode is given by formula (1):

$$(1) I_{dcm} = \frac{V_{out}(M-1)}{2M^3 f_s L}, \text{ where } M = \frac{V_{out}}{V_{in}}$$

The boost converter operates in CCM for $I_{out} > I_{dcm}$. Figure 1 shows the inductor current and voltage waveforms. For an ideal loss-less boost converter in CCM the duty-cycle D_{cm} is related to the voltage conversion ratio M through the formula (2):

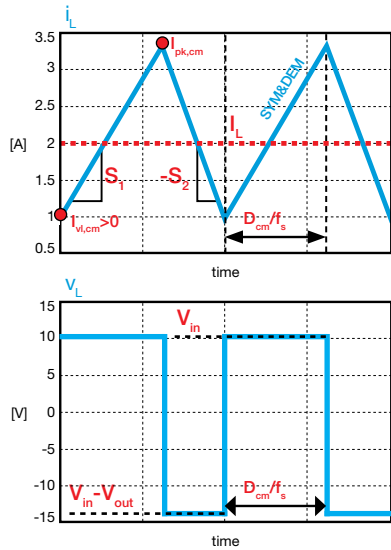

Figure 2. $V_{in}=9V, I_{out}=2A$

$$(2) D_{cm} = 1 - \frac{1}{M}$$

The inductor current slopes, average, peak and valley values are then given by:

$$(3) s_1 = \frac{V_{in}}{L}, s_2 = \frac{V_{out} - V_{in}}{L}, I_L = \frac{I_{out}}{(1-D_{cm})}$$

$$I_{pk,cm} = I_L + \frac{s_1 D_{cm}}{2f_s}, I_{vl,cm} = I_L - \frac{s_2(1-D_{cm})}{2f_s}$$

Due to the power losses, the real voltage conversion ratio M and the duty-cycle D_{cm} in CCM depend on the load current:

$$(4) M \cong \frac{1}{(1-D_{cm})} - \frac{P_d}{V_{in} I_{out}}, D_{cm} \cong 1 - \frac{V_{in} I_{out}}{P_{out} + P_d}$$

where P_d are the total losses of the power converter, which do depend on the duty-cycle D_{cm} as well. Increasing the power losses reduces the maximum allowed step-up conversion ratio M_{max} and increases the duty-cycle needed to get a given ratio M .

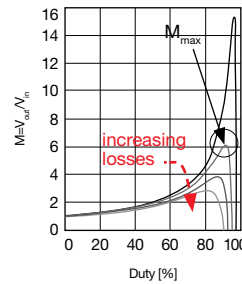

Figure 3. $V_{in}=10V, I_{out}=2.0A, L=10\mu H$

Load current below the DCM threshold

If $I_{out} < I_{dcm}$, in DEM the LM5122 boost regulator operates in DCM. The duty-cycle is given by (5):

$$(5) D_{dm} = \sqrt{M(M-1)K}, \text{ where } K = \frac{2f_s I_{out} L}{V_{out}}$$

Formula (5) does not include power losses effect and shows that the the duty-cycle D_{dm} in DCM inherently depends on the load current. Figure 4 compares inductor current and voltage ideal waveforms (the effect of parasitic capacitance is neglected) in DEM and SOM for $I_{out} < I_{dcm}$. For DEM it is $I_{pk,dm} = s_1 D_{dm}/f_s$ and $I_{vl,dm} = 0$. The formulae (2) and (3) are still valid for SOM.

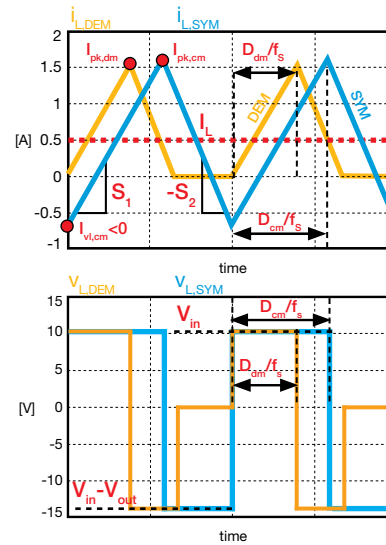

Figure 4. $V_{in}=9V, I_{out}=0.5A$

In DEM-DCM, for any value of the duty-cycle D_{dm} , the voltage conversion ratio M is also dependent on the load, and is given by (6):

$$(6) M \cong \frac{1}{2} + \sqrt{\frac{1}{4} + \frac{1}{K} D_{dm}^2}$$

Figure 5(a) shows the plot of the formula (6). DCM is operated for values of the line voltage V_{in} falling within a certain range $[V_{min}, V_{max}]$, which depends on the load current I_{out} and switching frequency f_s , as shown in Figure 5(b). The magenta and green curves are obtained with $I_{dcm} = I_{out}$ at $f_s = 250kHz$ and $f_s = 500kHz$.

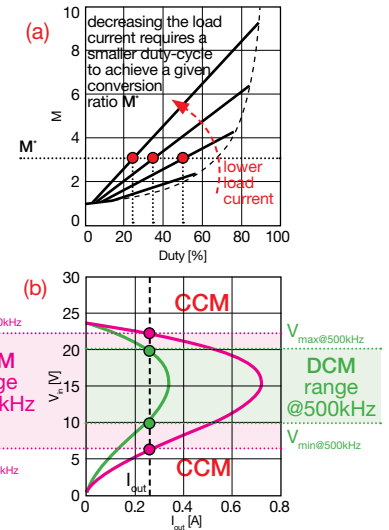

Figure 5. $V_{out}=24V, L=10\mu H$



Experiment set-up: configuration

The instruments needed for this experiment are: a DC POWER SUPPLY, four MULTIMETERS, an OSCILLOSCOPE and a DC ELECTRONIC LOAD. Figure 6 shows the instruments connections. Follow the instructions provided in next page to set-up the **connections**.

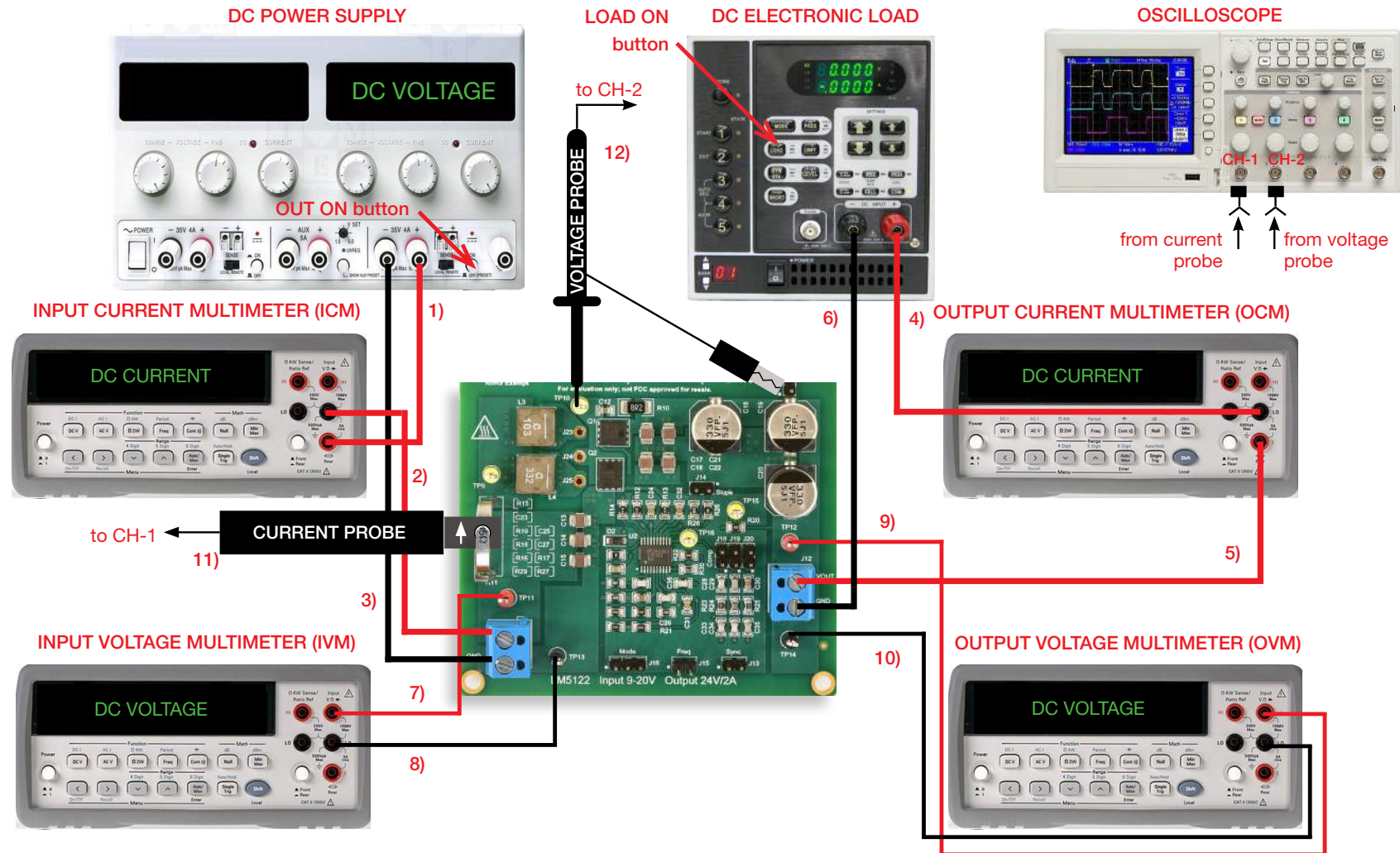

Figure 6. Experiment set-up.



Experiment set-up: instructions

With all the instruments turned off, make the following **connections**:

- 1) connect the POSITIVE (RED) OUTPUT of the DC POWER SUPPLY to the POSITIVE (RED) CURRENT INPUT of the INPUT CURRENT MULTIMETER (ICM)
- 2) connect the NEGATIVE (BLACK) CURRENT INPUT of the INPUT CURRENT MULTIMETER (ICM) to the INPUT (VIN) of the J_{11} screw terminal of the LM5122 boost regulator
- 3) connect the NEGATIVE (BLACK) OUTPUT of the DC POWER SUPPLY to the GROUND (GND) of the J_{11} screw terminal of the LM5122 boost regulator
- 4) connect the OUTPUT (VOUT) of the J_{12} screw terminal of the LM5122 boost regulator to the POSITIVE (RED) CURRENT INPUT of the OUTPUT CURRENT MULTIMETER (OCM)
- 5) connect the NEGATIVE (BLACK) CURRENT INPUT of the OUTPUT CURRENT MULTIMETER (OCM) to the POSITIVE (RED) INPUT of the ELECTRONIC LOAD
- 6) connect the NEGATIVE (BLACK) INPUT of the ELECTRONIC LOAD to the GROUND (GND) of the J_{12} screw terminal of the LM5122 boost regulator
- 7) connect the POSITIVE (RED) VOLTAGE INPUT of the INPUT VOLTAGE MULTIMETER (IVM) to the TEST PIN TP_{11} which is the VIN of the LM5122 boost regulator
- 8) connect the NEGATIVE (BLACK) VOLTAGE INPUT of the INPUT VOLTAGE MULTIMETER (IVM) to the TEST PIN TP_{13} which is GND of the LM5122 boost regulator
- 9) connect the POSITIVE (RED) VOLTAGE INPUT of the OUTPUT VOLTAGE MULTIMETER (OVM) to the TEST PIN TP_{12} which is VOUT of the LM5122 boost regulator
- 10) connect the NEGATIVE (BLACK) VOLTAGE INPUT of the OUTPUT VOLTAGE MULTIMETER (OVM) to the TEST PIN TP_{14} which is GND of the LM5122 boost regulator
- 11) connect a current probe to channel 1 of the oscilloscope and hang it on the sensing resistor R_{11} of the LM5122 boost regulator, ensuring that the arrow printed on the probe clamps corresponds to the current that enters the inductor (the arrow must point upside when looking the LM5122 boost board frontally, as shown in Figure 6)
- 12) connect a voltage probe to channel 2 of the oscilloscope and hang it on the TEST PIN TP_{10} which is the switching node voltage of the LM5122 boost regulator



Test#1: preparation and procedure

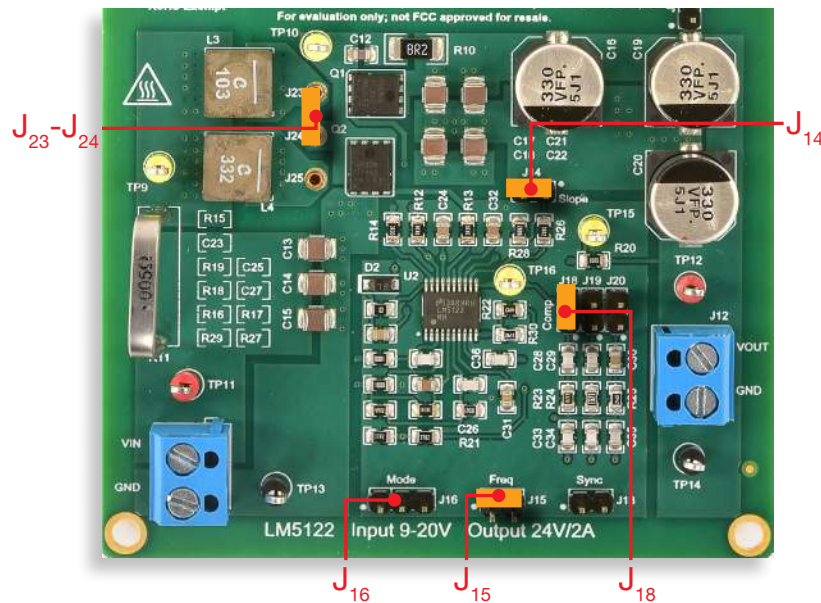

Figure 7. LM5122 board: jumpers set-up for Test#1

Initial jumpers set-up (see Figure 7):

- J_{13} open → no external synchronization signal connected
- J_{14} shorted → high slope current mode compensation
- J_{15} shorted → switching frequency $f_s = 500\text{kHz}$
- J_{16} open → DEM setup (change to J_{16} shorted on the left → SOM setup, according to *Measure and Calculate* section instructions)
- J_{18} shorted, J_{19} open, J_{20} open → error amplifier gain setup with parts R_{23} , C_{28} , C_{33} connected (high cross-over frequency with $L = L_3 = 10\mu\text{H}$, and high slope compensation ramp)
- J_{23} - J_{24} shorted → L_3 ($10\mu\text{H}$) inductor connected

Test Procedure:

- 1) turn on the MULTIMETERS, set the ICM and the OCM in DC CURRENT MODE, set the IVM and the OVM in DC VOLTAGE MODE
- 2) turn on the OSCILLOSCOPE, set the CH-1 in DC 50Ω coupling mode, set the CH-2 in DC $1\text{M}\Omega$ coupling mode, select CH-2 as trigger source, and execute the “de-gauss” of the current probe to remove possible dc bias in the current probe
- 3) turn on the POWER SUPPLY (ensure that the OUT ON button is OFF), set the voltage at the initial value of 10V, and set the CURRENT LIMIT $> 5\text{A}$
- 4) turn on the ELECTRONIC LOAD (ensure that the LOAD ON button is OFF), set the CONSTANT CURRENT MODE, and set the current at 0.2A
- 5) turn ON the POWER SUPPLY “OUT ON” button and adjust the DC POWER SUPPLY knob until you read 10V in the IVM display. In these conditions you should read about 24V in the OVM display, 0A in the OCM display and a very small positive value in the ICM display (if you do read values different than as described above, turn OFF the “OUT ON” button of the DC POWER SUPPLY and verify the previous steps)
- 6) turn ON the ELECTRONIC LOAD ON button and adjust the DC POWER SUPPLY knob until you read 10V in the IVM display. In these conditions you should read about 24V in the OVM display, 0.2A in the OCM display, about 0.5A in the ICM display, and see a triangular wavelshape with about 0.5A average value on CH-1 of the OSCILLOSCOPE and a swinging wave on CH-2 of the OSCILLOSCOPE (if the values you read and the waveforms you see do not look as described above, turn OFF the “LOAD ON” button of the ELECTRONIC LOAD and the “OUT ON” button of the DC POWER SUPPLY and verify the experiment setup)
- 7) read the input voltage value on the IVM display, the output voltage value on the OVM display, watch at the inductor current waveform on CH-1 of the OSCILLOSCOPE to assess whether the regulator is operating in CCM or DCM, measure the frequency and duty-cycle of the switching node voltage on CH-2 of the OSCILLOSCOPE, and use these values according to *Measure and Calculate* section instructions. Repeat this step for all the load current and input voltage values listed in Table 1 (you do not need to turn OFF the POWER SUPPLY “OUT ON” button and the ELECTRONIC LOAD “LOAD ON” button while changing the input voltage and the load current)
- 8) turn OFF the “LOAD ON” button of the ELECTRONIC LOAD and the “OUT ON” button of the DC POWER SUPPLY, open the jumper J_{16} to setup LM5122 DEM operation and repeat steps from 3) to 7)
- 9) at the end of the measurements, turn OFF the “LOAD ON” button of the ELECTRONIC LOAD and the “OUT ON” button of the DC POWER SUPPLY, then switch off all the instruments.



Test#1: measure and calculate

For each combination of the LM5122 boost regulator setup (DEM/SOM) and operating conditions (V_{in}, I_{out}) indicated in Table 1:

- 1) predict the CCM/DCM operation based on the relation between I_{out} and I_{dcm} illustrated in the *Theory Background* section and fill the cell ⁽¹⁾ with “CCM” or “DCM” label accordingly, verify whether the LM5122 boost regulator is operating in CCM or in DCM based on observation of the experimental inductor current waveform and fill the cell ⁽²⁾ with “CCM” or “DCM” label accordingly
- 2) based on the CCM/DCM operation predicted at point 1), calculate the duty-cycle D_{in} by means of the formulae (2), (5) and (6) given in the *Theory Background* section and report the result in cell ⁽³⁾
- 3) measure the experimental duty-cycle D_{ex} of the LM5122 boost regulator and report the result in cell ⁽⁴⁾

Table 1. Duty-cycle of the boost converter at $f_s = 500\text{kHz}$ with $L = 10\mu\text{H}$, with DEM and SOM setup.

⁽¹⁾ theor. CCM/DCM	⁽²⁾ exper. CCM/DCM	SOM operation						DEM operation							
		$I_{out}=0.2\text{A}$		$I_{out}=0.4\text{A}$		$I_{out}=1.2\text{A}$		$I_{out}=0.2\text{A}$		$I_{out}=0.4\text{A}$		$I_{out}=1.2\text{A}$			
⁽³⁾ theor. $D_{in} [\%]$	⁽⁴⁾ exper. $D_{ex} [\%]$														
$V_{in}=10\text{V}$		(1)	(2)	(1)	(2)	(1)	(2)	(1)	(2)	(1)	(2)	(1)	(2)		
		(3)	(4)	(3)	(4)	(3)	(4)	(3)	(4)	(3)	(4)	(3)	(4)		
$V_{in}=15\text{V}$		(1)	(2)	(1)	(2)	(1)	(2)	(1)	(2)	(1)	(2)	(1)	(2)		
		(3)	(4)	(3)	(4)	(3)	(4)	(3)	(4)	(3)	(4)	(3)	(4)		
$V_{in}=20\text{V}$		(1)	(2)	(1)	(2)	(1)	(2)	(1)	(2)	(1)	(2)	(1)	(2)		
		(3)	(4)	(3)	(4)	(3)	(4)	(3)	(4)	(3)	(4)	(3)	(4)		

Inductor:

J_{23} - J_{24} **shorted** → inductor L_3 (powdered core, $10\mu\text{H}$, 2.6A, 0.057Ω) connected
 J_{24} - J_{25} **shorted** → inductor L_4 (powdered core, $3.3\mu\text{H}$, 10A, 0.0195Ω) connected

Switching frequency:

J_{15} **open** → $f_s = 250\text{kHz}$
 J_{15} **shorted** → $f_s = 500\text{kHz}$

Operation mode:

J_{16} **open** → Diode Emulation Mode (DEM)
 J_{16} **shorted left** → Synchronous Operation Mode (SOM)

Answer:

- 1) Is the duty-cycle in DCM operation lower than in CCM operation?

<input type="checkbox"/> yes	<input type="checkbox"/> no	<input type="checkbox"/> it depends on load current	<input type="checkbox"/> it depends on line voltage
------------------------------	-----------------------------	---	---
- 2) Does the experimental duty-cycle increase with the load current?

<input type="checkbox"/> yes	<input type="checkbox"/> no	<input type="checkbox"/> it does in DCM operation	<input type="checkbox"/> it does in CCM operation
------------------------------	-----------------------------	---	---
- 3) Does the load current influence the duty-cycle more in DCM than in CCM?

<input type="checkbox"/> yes	<input type="checkbox"/> no	<input type="checkbox"/> it depends on line voltage
------------------------------	-----------------------------	---



Test#2: preparation and procedure

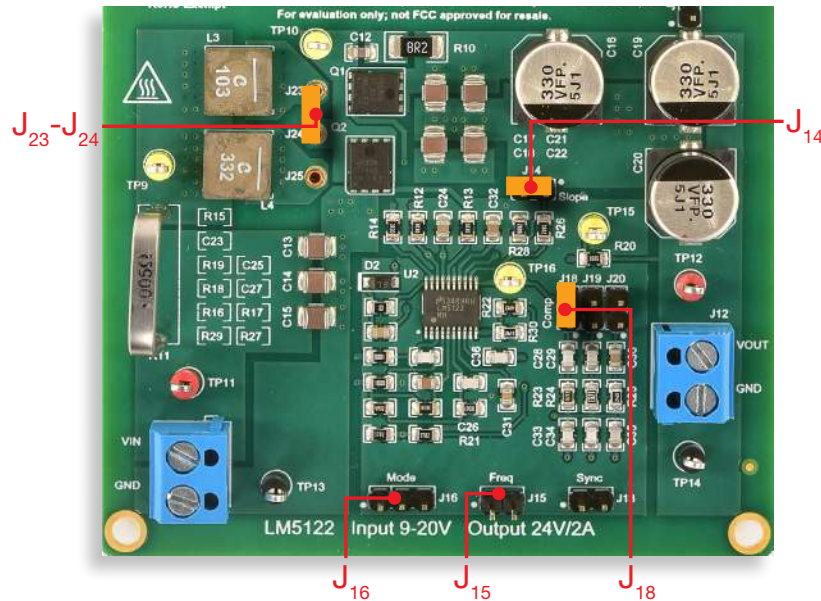

Figure 8. LM5122 board: jumpers set-up for Test#2

Initial jumpers set-up (see Figure 8):

- J_{13} open \rightarrow no external synchronization signal connected
- J_{14} shorted \rightarrow high slope current mode compensation
- J_{15} open \rightarrow switching frequency $f_s = 250\text{kHz}$
- J_{16} open \rightarrow DEM setup
- J_{18} shorted, J_{19} open, J_{20} open \rightarrow error amplifier gain setup with parts R_{23} , C_{28} , C_{33} connected (high cross-over frequency with $L = L_3 = 10\mu\text{H}$, and high slope compensation ramp)
- $J_{23} - J_{24}$ shorted $\rightarrow L_3$ ($10\mu\text{H}$) inductor connected

Test Procedure:

- 1) turn on the MULTIMETERS, set the ICM and the OCM in DC CURRENT MODE, set the IVM and the OVM in DC VOLTAGE MODE
- 2) turn on the OSCILLOSCOPE, set the CH-1 in DC 50Ω coupling mode, set the CH-2 in DC $1\text{M}\Omega$ coupling mode, select CH-2 as trigger source, and execute the “de-gauss” of the current probe to remove possible dc bias in the current probe
- 3) turn on the POWER SUPPLY (ensure that the OUT ON button is OFF), set the voltage at the initial value of 10V, and set the CURRENT LIMIT $> 5\text{A}$
- 4) turn on the ELECTRONIC LOAD (ensure that the LOAD ON button is OFF), set the CONSTANT CURRENT MODE, and set the current at 0.3A
- 5) turn ON the POWER SUPPLY “OUT ON” button and adjust the DC POWER SUPPLY knob until you read 10V in the IVM display. In these conditions you should read about 24V in the OVM display, 0A in the OCM display and a very small positive value in the ICM display (if you do read values different than as described above, turn OFF the “OUT ON” button of the DC POWER SUPPLY and verify the previous steps)
- 6) turn ON the ELECTRONIC LOAD ON button and adjust the DC POWER SUPPLY knob until you read 10V in the IVM display. In these conditions you should read about 24V in the OVM display, 0.3A in the OCM display, about 0.75A in the ICM display, and see a triangular wavelshape with about 0.75A average value on CH-1 of the OSCILLOSCOPE and a swinging wave on CH-2 of the OSCILLOSCOPE (if the values you read and the waveforms you see do not look as described above, turn OFF the “LOAD ON” button of the ELECTRONIC LOAD and the “OUT ON” button of the DC POWER SUPPLY and verify the experiment setup)
- 7) while slowly rising the input voltage from 10V to 20V (read the input voltage on the IVM display, not on DC POWER SUPPLY display), watch the inductor current waveform on CH-1 of the OSCILLOSCOPE to assess whether the regulator is operating in CCM or DCM, detect the minimum and maximum input voltage values for which the regulator operates in DCM, and report these values in Table 2. Repeat this step for all the load current values listed in Table 2 (you do not need to turn OFF the POWER SUPPLY “OUT ON” button and the ELECTRONIC LOAD “LOAD ON” button while changing the input voltage and the load current)
- 8) turn OFF the “LOAD ON” button of the ELECTRONIC LOAD and the “OUT ON” button of the DC POWER SUPPLY, short the jumper J_{15} to setup the switching frequency at $f_s = 500\text{kHz}$ and repeat steps from 3) to 7)
- 9) at the end of the measurements, turn OFF the “LOAD ON” button of the ELECTRONIC LOAD and the “OUT ON” button of the DC POWER SUPPLY, then switch off all the instruments.



Test#2: measure and calculate

For each combination of switching frequency f_s and load current I_{out} indicated in Table 2:

- report the minimum input voltage V_{inmin} and the maximum input voltage V_{inmax} for which the LM5122 boost regulator is operating in DCM, based on the observation of the experimental inductor current waveform (write “CCM” into the cells ⁽¹⁾ and ⁽²⁾ in case the regulator operates in CCM for whatever voltage from 10V to 20V)
- based on the formula (1) given in the *Theory Background* section, calculate the I_{dcm} threshold current at the voltages V_{inmin} and V_{inmax} detected at point 1) and report the result in cells ⁽³⁾ and ⁽⁴⁾

Table 2. Impact of load current and switching frequency on the input voltage DCM operation range of LM5122 boost regulator with DEM setup and $L = 10\mu\text{H}$

(1) V_{inmin} [V]	(2) V_{inmax} [V]	$f_s = 250\text{kHz}$						$f_s = 500\text{kHz}$						
		(3) $I_{dcm}@V_{inmin}$ [A]	(4) $I_{dcm}@V_{inmax}$ [A]	(1)	(2)	(3)	(4)	(1)	(2)	(3)	(4)	(1)	(2)	
$I_{out}=0.3\text{A}$	(1)	(2)	(1)	(2)	(1)	(2)	(1)	(2)	(1)	(2)	(1)	(2)	(1)	(2)
	(3)	(4)	(3)	(4)	(3)	(4)	(3)	(4)	(3)	(4)	(3)	(4)	(3)	(4)
$I_{out}=0.6\text{A}$	(1)	(2)	(1)	(2)	(1)	(2)	(1)	(2)	(1)	(2)	(1)	(2)	(1)	(2)
	(3)	(4)	(3)	(4)	(3)	(4)	(3)	(4)	(3)	(4)	(3)	(4)	(3)	(4)
$I_{out}=0.9\text{A}$	(1)	(2)	(1)	(2)	(1)	(2)	(1)	(2)	(1)	(2)	(1)	(2)	(1)	(2)
	(3)	(4)	(3)	(4)	(3)	(4)	(3)	(4)	(3)	(4)	(3)	(4)	(3)	(4)

Inductor:

$J_{23}-J_{24}$ shorted → inductor L_3 (powdered core, $10\mu\text{H}$, 2.6A, 0.057Ω) connected
 $J_{24}-J_{25}$ shorted → inductor L_4 (powdered core, $3.3\mu\text{H}$, 10A, 0.0195Ω) connected

Switching frequency:

J_{15} open → $f_s = 250\text{kHz}$
 J_{15} shorted → $f_s = 500\text{kHz}$

Operation mode:

J_{16} open → Diode Emulation Mode (DEM)
 J_{16} shorted left → Synchronous Operation Mode (SOM)

Answer:

- 1 Does a higher load current expand the input voltage range where the boost regulator operates in DCM?

yes no, it reduces the range it depends on switching frequency other: _____

- 2 Identify the factors determining the reduction of input voltage range wherein the boost converter operates in DCM: _____

- 3 Are the values $I_{dcm}@V_{inmin}$ and $I_{dcm}@V_{inmax}$ equal to the value of the load current in the test conditions?

yes no it depends on switching frequency it depends on load current other: _____



Discussion

In Test#1 we are interested in detecting the CCM/DCM operation mode and measuring the duty-cycle of a boost regulator while varying the input voltage and the load current.

In the *Theory Background* section, the analysis shows that the LM5122 boost regulator enters DCM when $I_{out} < I_{dcm}$ with DEM setup. The threshold current I_{dcm} given by formula (1) depends on the input voltage V_{in} , the switching frequency f_s and the inductance L . The formula (1) provides an approximated value of the I_{dcm} threshold value, as it neglects the effects of power losses, of the temperature and variations (tolerances) of physical and operating parameters (e.g. inductance L , switching frequency f_s). The DCM operation can be detected experimentally by observing the waveforms of the inductor current (i_L), of the inductor voltage (v_L) or of the switching node voltage (v_{sw}). The waveforms of inductor current and voltage in DCM are shown in the Figure 4 of the *Theory Background* section. In theory, when a boost converter operates in DCM, the inductor current drops to zero before the end of the switching period, and stays at zero until the next switching cycle starts. During this dead interval (see *Figure 8 on next page*) the inductor voltage is zero, then the switching node voltage should drop below the output voltage and keep a constant value depending on the impedances of the MOSFET and of the diode in the OFF state. In a real boost converter, during the dead interval the parasitic capacitances of the MOSFET and of the diode form a resonant loop with the inductor, which causes oscillations in the inductor current and at the switching node voltage, as shown in Figure 8. The DCM operation can be assessed by detecting whether there is a zero crossing in the inductor current waveform, while the duty-cycle can be determined by the measuring the duration t_{Q2} of the time interval wherein the switching node voltage is clamped to zero because of the MOSFET Q_2 conduction (see *Figure 1 to identify MOSFETs Q_1 and Q_2*).

In Test#2 we are interested in analyzing the impact of the switching frequency on the operation of a boost regulator while varying the input voltage.

Given a load current I_{out} , the LM5122 boost regulator operating with DEM setup enters DCM or CCM depending on whether the load current I_{out} is lower or greater than the value of the threshold current I_{dcm} . The formula (1) provided in the *Theory Background* section shows that an increase of the switching frequency f_s causes a decrease of the threshold current I_{dcm} , and then the LM5122 boost regulator operating with DEM setup operates in CCM over a wider range of values of the load current. The impact of the input voltage on the threshold current I_{dcm} is non-monotonic. In fact, the formula (1) can be derived with respect to the conversion ratio $M=V_{out}/V_{in}$ and it results that if $V_{in} > 0.67V_{out}$ then the threshold current I_{dcm} decreases while V_{in} increases, whereas if $V_{in} < 0.67V_{out}$ then the threshold current I_{dcm} increases while V_{in} increases. You can observe from experimental tests that when the load current falls below a certain threshold, the operation of the LM5122 boost regulator with DEM setup becomes irregular, and you may have some difficulty in setting the oscilloscope trigger. This behaviour is determined by a typical property of control ICs, which cannot operate with too small or too large duty-cycle. In particular, the formula (5) shows that the duty-cycle in DCM decreases as the load current decreases. When the load current I_{out} is much lower than the threshold current I_{dcm} , a very small duty cycle is required to achieve the regulation of the output voltage. In these conditions it can happen that the required ON time t_{Q2} of the MOSFET Q_2 is lower than the minimum ON time t_{ONmin} that the controller can implement. For the LM5122 controller t_{ONmin} varies between 150ns and 300ns while the slope compensation resistance R_{slope} of Figure 1 goes from 5k Ω to 200k Ω (see [4] for more details on LM5122 and *Experiment 5 to get an insight on the function of the slope compensation resistance*). If $t_{ONmin}=300ns$, the minimum duty-cycle the LM5122 can implement at $f_s=500kHz$ is $D_{min}=t_{ONmin}f_s=0.15$. If $V_{in}=20V$ and $L=10\mu H$, based on formula (5) the minimum duty-cycle $D_{min}=0.15$ corresponds to a load current $I_{out}=225mA$. If the load demands a current lower than 225mA, the LM5122 controller operating with DEM setup features a skip cycle mode, which periodically maintains the gate driver of MOSFET Q_2 OFF over a certain number of switching cycles and then restarts the regular switching mode for a certain interval of time. The duration of the skip cycle mode interval increases while the load current decreases. This operation is clearly shown in Figures 10 and 11. The skip cycle mode involves beneficial effects on the efficiency at low load, as the switching losses of the MOSFET Q_2 are suppressed while suspending the switching operation (see *Experiment 2 for further investigations on power losses and efficiency of the boost converter*).



Experimental plots

The plots collected in the Figures 8 to 11 show the inductor current and the switching node voltage of the LM5122 boost regulator in different setup and operating conditions.

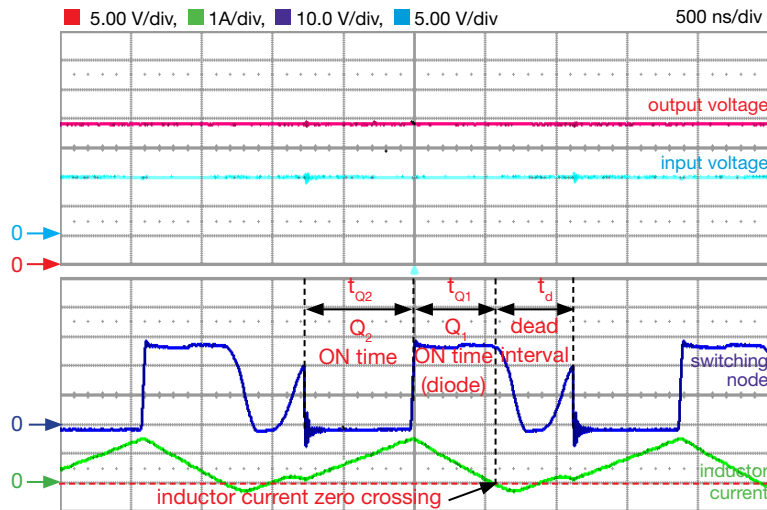

Figure 8. DCM steady-state operation (DEM setup):
 $V_{in}=10V$, $I_{out}=0.2A$, $f_s=250kHz$, $L=10\mu H$

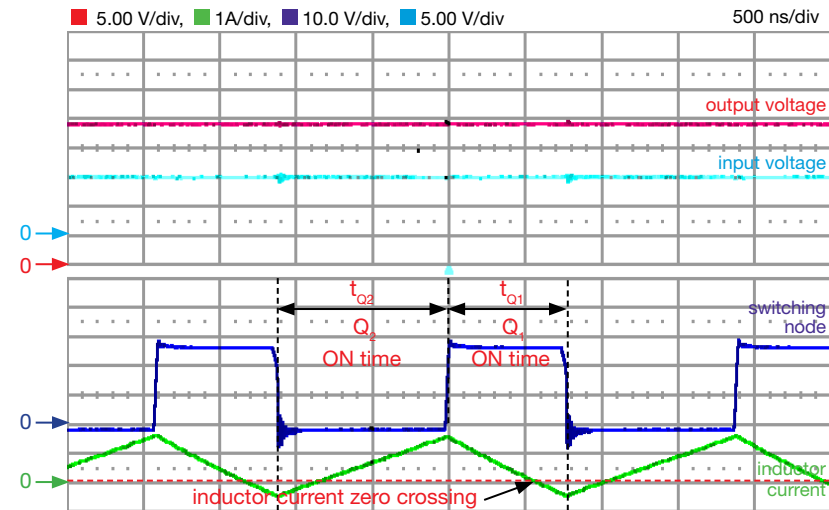

Figure 9. CCM steady-state operation (SOM setup):
 $V_{in}=10V$, $I_{out}=0.2A$, $f_s=250kHz$, $L=10\mu H$

Figures 8 and 9 highlight the difference between the waveforms of the LM5122 boost regulator operating in DCM (Figure 8) and in CCM (Figure 9), when the load current I_{out} is lower than the threshold current I_{dcm} . You can see that, for the same input voltage V_{in} , load current I_{out} , switching frequency f_s and inductance L , the boost regulator works in DCM with DEM setup and enters the idle interval (dead time) after the inductor current zero crossing. In these conditions, the gate drive of the MOSFET Q_1 is shut down and its body diode cannot sustain negative current when the MOSFET Q_2 is turned OFF. When the LM5122 boost regulator operates with SOM setup, the DCM cannot occur, despite of the inductor current zero crossing. In fact, with SOM setup, the gate drive of the MOSFET Q_1 is switched ON when the MOSFET Q_2 is turned OFF, and the MOSFET Q_1 can sustain negative current. Figures 8 and 9 also highlight that the duty-cycle of the boost regulator operating in DCM is lower than the duty cycle of the boost regulator operating in CCM. In fact, in Figure 8 the ON time of the MOSFET Q_2 , which determines the duty-cycle $D=t_{o2}/f_s$, is shorter than in Figure 9.

[NOTE: The decision about whether to use the DEM or the SOM setup in real world applications can be based on the assessment of which one between the two operation modes provides the best efficiency performance of the converter (see [Experiment 2](#) to get an insight on power losses of the boost regulator with DEM vs SOM)].



Experimental plots

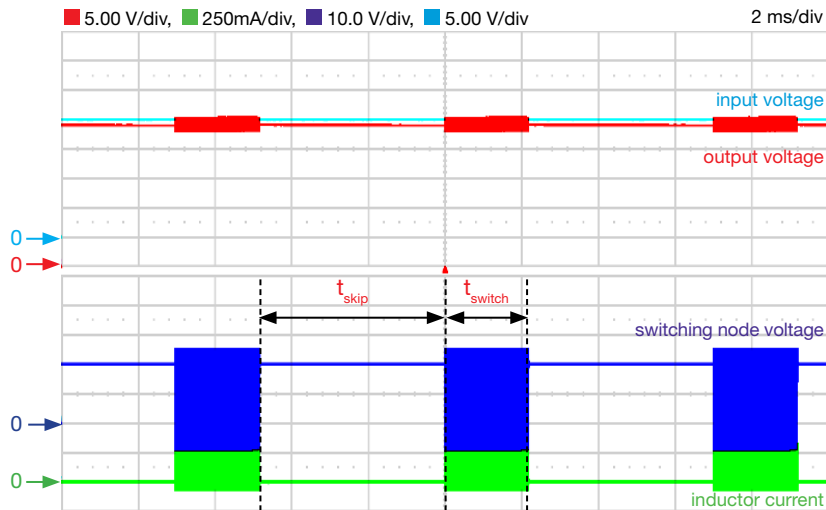

Figure 10. DEM steady-state operation:
 $V_{in}=20V$, $I_{out}=25mA$, $f_s=500kHz$, $L=10\mu H$

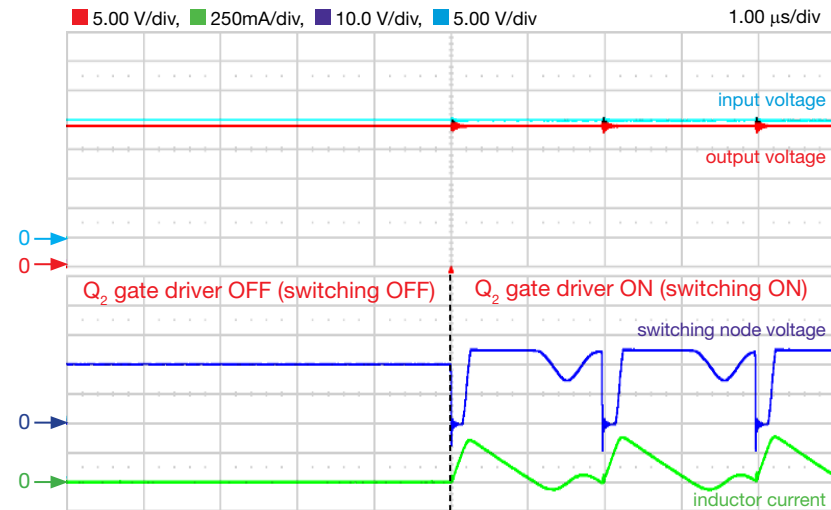

Figure 11. DEM steady-state operation:
 $V_{in}=20V$, $I_{out}=25mA$, $f_s=500kHz$, $L=10\mu H$

Figures 10 and 11 show the waveforms of the LM5122 boost regulator in *skip cycle mode*, determined by a low load current requiring a duty-cycle smaller than the minimum allowed by the controller. The *skip cycle mode* is a kind of *burst operation*. It involves the periodical alternation of two intervals of time, wherein the MOSFET gate driver is activated and de-activated respectively. During the t_{skip} interval, the Q_2 MOSFET gate driver is permanently OFF, so that the inductor is never charged, its current is zero and the body-diode of the Q_1 MOSFET is reverse biased. In fact, as you can see in the figure 10, the switching node voltage equals the input voltage $V_{in} = 20V$, which is lower than the output voltage $V_{out} = 24V$. Therefore, during the t_{skip} interval the current is delivered to the load by the output capacitor, which decreases with a rate $dV_{out}/dt = I_{out}/C_{out}$. When the output voltage drop exceeds a lower hysteresis threshold [4], the Q_2 MOSFET gate driver is re-activated, and during the t_{switch} interval, the controller features the regular switching mode. During this interval the regulator compensates for the charge drop caused in the output capacitor by the skip cycle mode featured in the preceding interval t_{skip} . When the output voltage rises above an upper hysteresis threshold [4], the LM5122 returns into the skip cycle mode, and the sequence repeats periodically. The result is that the output voltage is regulated at the desired average 24V value (as shown by the red traces), with a burst ripple at the frequency $f_{SC} = 1/T_{SC}$, where $T_{SC} = t_{skip} + t_{switch}$. The frequency f_{SC} decreases with the load current. Figure 11 is a zoom of Figure 10 and shows the instant of transition from the skip-cycle mode to the switching mode

[NOTE: The impact of skip-cycle operation on the efficiency at low load can help decide whether to be in DEM or SOM in real world applications]

Experiment 2

The goal of this experiment is to analyze the impact of the operating conditions and of the operation mode on the power losses and efficiency of the boost converter. The LM5122 BOOST regulator is used for this experiment.



Case Study

The goal of this experiment is to analyze how the efficiency of the boost converter changes with the operating conditions and with the operation mode.

The TI-PMLK LM5122 boost regulator operates with $V_{in}=[9,20]V^{(1)}$, $V_{out}=24V$, $I_{out}=[0,2]A$. Fig.1 shows the basic circuit schematic. The power devices highlighted in Fig.1 are: the input capacitor (C_{in}), the inductor (L), the output capacitor (C_{out}), the MOSFETs (Q_1, Q_2), the feedback compensation ($R_{fb1}, R_{fb2}, C_{f1}, R_{f2}, C_{f2}$), the current slope compensation (R_{slope}) and the inductor current sensing resistor (R_s). The jumper J_{16} allows to select different operation modes: in **Diode Emulation Mode (DEM)** operation, Q_1 gate is disabled, so Q_1 emulates a diode and the boost converter can operate in **Discontinuous Conduction Mode (DCM)** at low load; in **Synchronous Operation Mode (SOM)**⁽²⁾, the Q_1 gate is enabled and then the boost converter operates in **Continuous Conduction Mode (CCM)** at any load. In the *Experiment 1* you have investigated the impact of CCM and DCM operation on duty-cycle and conversion ratio. In this experiment the impact of CCM/DCM operation on the boost regulator efficiency is analyzed. Formulae for loss and efficiency calculations in boost regulator are discussed in detail in the *Theory Background* section.

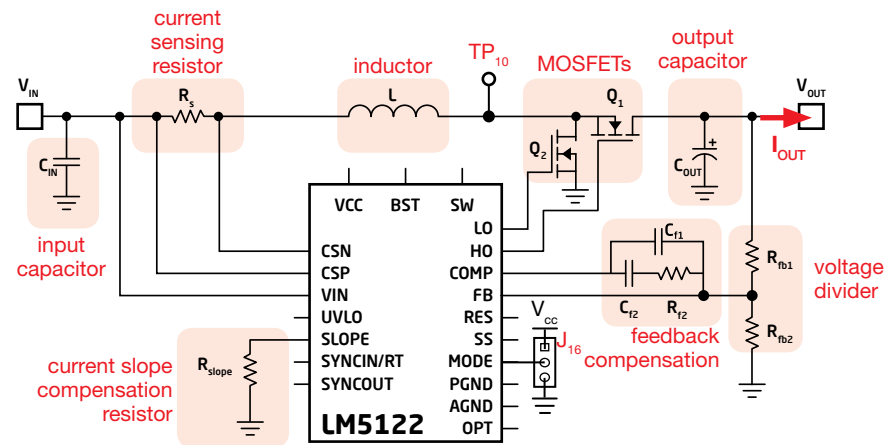

Figure 1. Simplified schematic of the LM5122 BOOST regulator

⁽¹⁾ Restricted range adopted for this educational board, compared to the 4.5V to 65V full range of LM5122 [4]

⁽²⁾ Also defined Forced PWM Mode [4]

Test#1. We measure the power losses of the boost converter for different values of input voltage and load current. The test is realized for given input voltage and load current conditions with different setup of jumper J_{16} , which determines the DEM or SOM setup. The DCM is detected by analyzing the inductor current waveform flowing through the current sensing resistor R_s (R_{11} in the board) whereas the duty-cycle is measured by analyzing the switching node voltage at TEST PIN TP_{10} .

Test#2. We analyze the impact of the switching frequency on the efficiency of the boost converter while varying the load current. The test is realized for two different line voltage values and with different setup of jumper J_{15} , which determines the switching frequency. The results of the formulae which predict the MOSFET and inductor power losses are compared with measurement results to verify if the relevant trends are consistent.



Theory Background

The losses of power devices in boost converter in DEM and SOM can be analyzed by means of the following simplified formulae (see [1] for more details on boost topology operation and CCM/DCM modeling, [2] for MOSFETs losses calculation, [4] for more details on LM5122 operation and features; refer to Figure 1 to determine inductor and MOSFETs voltages and currents)

Load current above DCM threshold

Figure 2 shows the inductor current of a boost converter when $I_{out} > I_{dcm}$, where:

$$(1) \quad I_{dcm} = \frac{V_{out}(M-1)}{2M^3 f_s L} \quad M = \frac{V_{out}}{V_{in}}$$

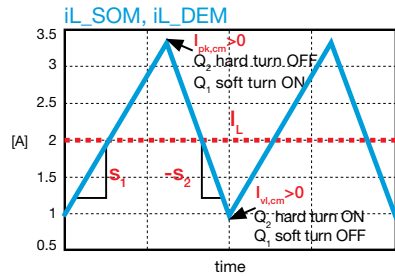

Figure 2

The inductor current slopes, average, peak and valley values are given by:

$$(2) \quad s_1 = V_{in}/L, \quad s_2 = (V_{out} - V_{in})/L$$

$$(3) \quad I_L = I_{out}/(1-D_{cm}), \quad D_{cm} = 1 - V_{in}/V_{out}$$

$$(4) \quad I_{pk,cm} = I_L + s_1 D_{cm}/(2f_s), \quad I_{vl,cm} = I_L - s_2/(1-D_{cm})/(2f_s)$$

If $I_{out} > I_{dcm}$, it is also $I_{vl,cm} > 0$. The MOSFETs and the inductor cause the main conduction losses, which can be calculated by means of the simplified formulae (5) to (16).

Inductor winding losses

$$(5) \quad P_{c,L}^{SY} = ESR_L I_L^2 \alpha_{pp} = P_{c,L}^{DE}$$

Inductor core losses

$$(6) \quad P_{m,L}^{SY} = f_s / (C_1 / \gamma^3 + C_2 / \gamma^{2.3} + C_3 / \gamma^{1.65}) + C_4 (f_s \gamma)^2$$

MOSFET Q₂ conduction losses

$$(7) \quad P_{c,Q2}^{SY} = R_{ds}^{Q2} D_{cm} I_L^2 \alpha_{pp} = P_{c,Q2}^{DE}$$

MOSFET Q₁ total conduction losses (SOM)

$$(8) \quad P_{c,Q1}^{SY} = R_{ds}^{Q1} (1 - D_{cm}) I_L^2 \alpha_{pp} + P_{dt,Q1}^{SY}$$

MOSFET Q₁ body-diode losses (SOM)

$$(9) \quad P_{dt,Q1}^{SY} = 2V_{SD,Q1} t_{dt} f_s I_L$$

MOSFET Q₁ total conduction losses (DEM)

$$(10) \quad P_{c,Q1}^{DE} = V_{SD,Q1} (1 - D_{cm}) I_L$$

where $\alpha_{pp} = 1 + (\Delta i_{pp} / I_L)^2 / 12$, $\Delta i_{pp} = I_{pk,cm} - I_{vl,cm}$ and $\gamma = C_5 \Delta i_{pp}$. The MOSFET Q₂ causes the main switching losses, which can be calculated by means of the following simplified formulae:

MOSFET Q₂ total switching losses

$$(13) \quad P_{sw,Q2}^{SY} = \frac{1}{2} V_{out} f_s (I_{vt} t_{on}^{Q2} + I_{pk} t_{off}^{Q2}) + P_{sw,Q2}^{DE}$$

MOSFETs additional losses

$$(14) \quad P_Q^{SY} = \left[2V_{dr} Q_g + Q_{rr} V_{out} + \frac{C_{oss} V_{out}^2}{2} \right] f_s$$

$$(15) \quad t_{on}^{Q2} = \frac{Q_{gs}^{Q2} (R_{gint}^{Q2} + R_{up})}{V_{dr} - V_{th}^{Q2} - I_{vl,cm} / g_{FS}^{Q2}} \quad \text{Q}_2 \text{ turn ON time}$$

$$(16) \quad t_{off}^{Q2} = \frac{Q_{gs}^{Q2} (R_{gint}^{Q2} + R_{down})}{V_{th}^{Q2} + I_{pk,cm} / g_{FS}^{Q2}} \quad \text{Q}_2 \text{ turn OFF time}$$

Load current below DCM threshold

Figure 3 shows the inductor current of a boost converter when $I_{out} < I_{dcm}$.

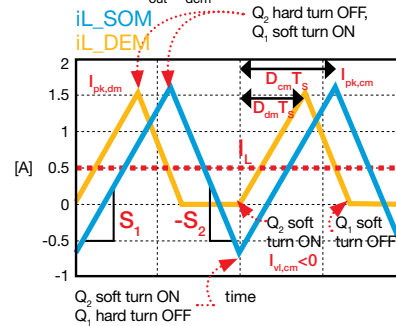

Figure 3

The inductor current peak value of the boost converter in DEM is given by:

$$(17) \quad I_{pk,dm} = \frac{s_1 D_{dm}}{f_s}$$

$$(18) \quad D_{dm} = \sqrt{M(M-1)K}, \quad K = \frac{2f_s I_{out} L}{V_{out}}$$

As DEM involves DCM, the valley current is zero, $I_{vl,dm} = 0$, whereas the slopes are the same as in CCM. As SOM prevents the operation in DCM, the formulae of inductor current slopes, average, peak and valley values for the boost converter in SOM operation with $I_{out} < I_{dcm}$ are the same of CCM, with the difference that the valley current is negative, $I_{vl,cm} < 0$.

The inductor and MOSFETs losses in SOM are:

$$(19) \quad P_{c,L}^{SY} = \frac{R_L (D_{cm}^3 s_1^2 + (1 - D_{cm})^3 s_2^2)}{12 f_s^2}$$

$$(20) \quad P_{c,Q2}^{SY} = \frac{R_{ds}^{Q2} s_1^2 D_{cm}^3}{12 f_s^2} - V_{SD,Q2} t_{dt} f_s I_{vl,cm}$$

$$(21) \quad P_{c,Q1}^{SY} = \frac{R_{ds}^{Q1} s_2^2 (1 - D_{cm})^3}{12 f_s^2} + V_{SD,Q1} t_{dt} f_s I_{pk,cm}$$

$$(22) \quad P_{sw}^{SY} = \frac{1}{2} V_{out} f_s (I_{pk,cm} t_{off}^{Q2} - I_{vl,cm} t_{on}^{Q1}) + P_Q^{SY}$$

$$(23) \quad P_Q^{SY} = (2V_{dr} Q_g + 2Q_{rr} V_{out} + \frac{C_{oss} V_{out}^2}{2}) f_s$$

$$(24) \quad t_{on}^{Q1} = \frac{Q_{gs}^{Q1} (R_{gint}^{Q1} + R_{Lup})}{V_{dr} - V_{th}^{Q1} + I_{vl,cm} / g_{FS}^{Q1}}$$

$$(25) \quad t_{off}^{Q2} = \frac{Q_{gs}^{Q2} (R_{gint}^{Q2} + R_{Ldown})}{V_{th}^{Q2} + I_{pk,cm} / g_{FS}^{Q2}}$$

The inductor and MOSFETs losses in DEM are:

$$(26) \quad P_{sw}^{DE} = \frac{1}{2} V_{out} f_s t_{off}^{Q2} I_{pk,dm} + P_Q^{DE}$$

$$(27) \quad P_Q^{DE} = (V_{dr} Q_g + \frac{C_{oss} V_{out}^2}{2}) f_s$$

$$(28) \quad P_{c,L}^{DE} = \frac{R_L s_1^2 D_{dm}^3 (s_1 + s_2)}{3 f_s^2 s_2}, \quad P_{c,Q2}^{DE} = \frac{R_{ds}^{Q2} s_1^2 D_{dm}^3}{3 f_s^2}$$

$$(29) \quad P_{c,Q1}^{DE} = \frac{R_{ds}^{Q1} s_2^3 D_{dm}^3}{3 f_s^2 s_2} + V_{SD,Q1} t_{dt} f_s I_{pk}$$

$$(30) \quad P_{m,L}^{DE} = f_s / (C_1 / \gamma^3 + C_2 / \gamma^{2.3} + C_3 / \gamma^{1.65}) + C_4 (f_s \gamma)^2$$

Legend • ESR_L = inductor winding resistance • C_1, C_2, C_3, C_4, C_5 = inductor magnetic core loss coefficients • R_{ds} = channel resistance • V_{th} = gate-source threshold voltage • V_{SD} = body diode forward voltage • g_{FS} = transconductance • Q_g = total gate charge • Q_{gs} = switching gate charge • Q_{rr} = reverse recovery charge • C_{oss} = output capacitance • R_{gint} = gate resistance • V_{dr} = gate driver voltage • R_{up}, R_{down} = gate driver pull-up and pull-down resistances (integrated in the controller) • t_{dt} = gate driver dead time (determined by the controller)

Good to know • The MOSFET parameters depend on the junction temperature • The layout influences the MOSFET switching times • The coefficients of the inductor core losses heuristic formula (6) depend on core material and temperature (see the manufacturer's website for more details on L_3 and L_4 parts and relevant losses)



Experiment set-up: configuration

The instruments needed for this experiment are: a DC POWER SUPPLY, four MULTIMETERS, an OSCILLOSCOPE and a DC ELECTRONIC LOAD. Figure 4 shows the instruments connections. Follow the instructions provided in next page to set-up the **connections**.

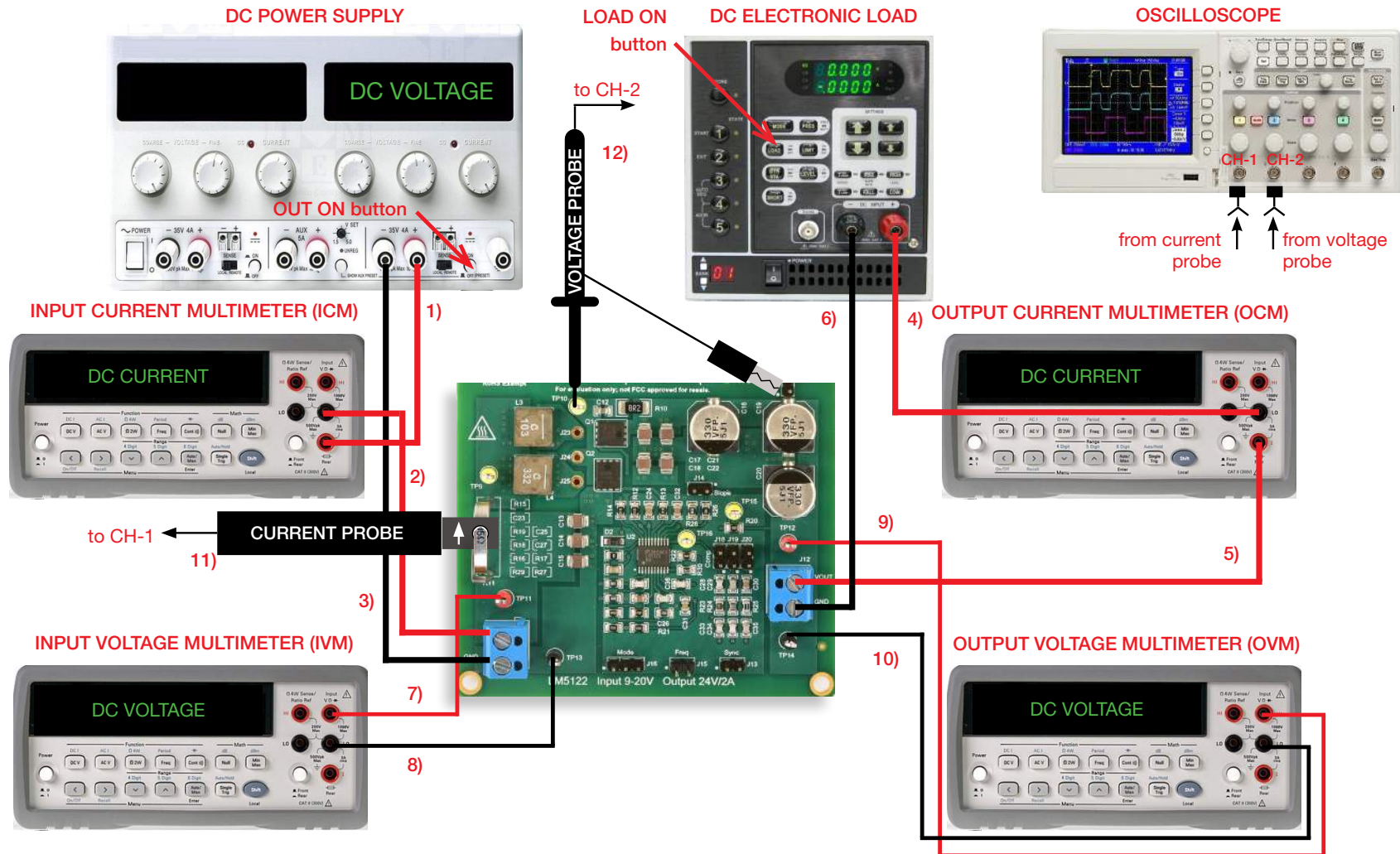

Figure 4. Experiment set-up.



Experiment set-up: instructions

With all the instruments turned off, make the following **connections**:

- 1) connect the POSITIVE (RED) OUTPUT of the DC POWER SUPPLY to the POSITIVE (RED) CURRENT INPUT of the INPUT CURRENT MULTIMETER (ICM)
- 2) connect the NEGATIVE (BLACK) CURRENT INPUT of the INPUT CURRENT MULTIMETER (ICM) to the INPUT (VIN) of the J_{11} screw terminal of the LM5122 boost regulator
- 3) connect the NEGATIVE (BLACK) OUTPUT of the DC POWER SUPPLY to the GROUND (GND) of the J_{11} screw terminal of the LM5122 boost regulator
- 4) connect the OUTPUT (VOUT) of the J_{12} screw terminal of the LM5122 boost regulator to the POSITIVE (RED) CURRENT INPUT of the OUTPUT CURRENT MULTIMETER (OCM)
- 5) connect the NEGATIVE (BLACK) CURRENT INPUT of the OUTPUT CURRENT MULTIMETER (OCM) to the POSITIVE (RED) INPUT of the ELECTRONIC LOAD
- 6) connect the NEGATIVE (BLACK) INPUT of the ELECTRONIC LOAD to the GROUND (GND) of the J_{12} screw terminal of the LM5122 boost regulator
- 7) connect the POSITIVE (RED) VOLTAGE INPUT of the INPUT VOLTAGE MULTIMETER (IVM) to the TEST PIN TP_{11} which is the VIN of the LM5122 boost regulator
- 8) connect the NEGATIVE (BLACK) VOLTAGE INPUT of the INPUT VOLTAGE MULTIMETER (IVM) to the TEST PIN TP_{13} which is GND of the LM5122 boost regulator
- 9) connect the POSITIVE (RED) VOLTAGE INPUT of the OUTPUT VOLTAGE MULTIMETER (OVM) to the TEST PIN TP_{12} which is VOUT of the LM5122 boost regulator
- 10) connect the NEGATIVE (BLACK) VOLTAGE INPUT of the OUTPUT VOLTAGE MULTIMETER (OVM) to the TEST PIN TP_{14} which is GND of the LM5122 boost regulator
- 11) connect a current probe to channel 1 of the oscilloscope and hang it on the sensing resistor R_{11} of the LM5122 boost regulator, ensuring that the arrow printed on the probe clamps corresponds to the current that enters the inductor (the arrow must point upside when looking the LM5122 boost board frontally, as shown in Figure 6)
- 12) connect a voltage probe to channel 2 of the oscilloscope and hang it on the TEST PIN TP_{10} which is the switching node voltage of the LM5122 boost regulator



Test#1: preparation and procedure

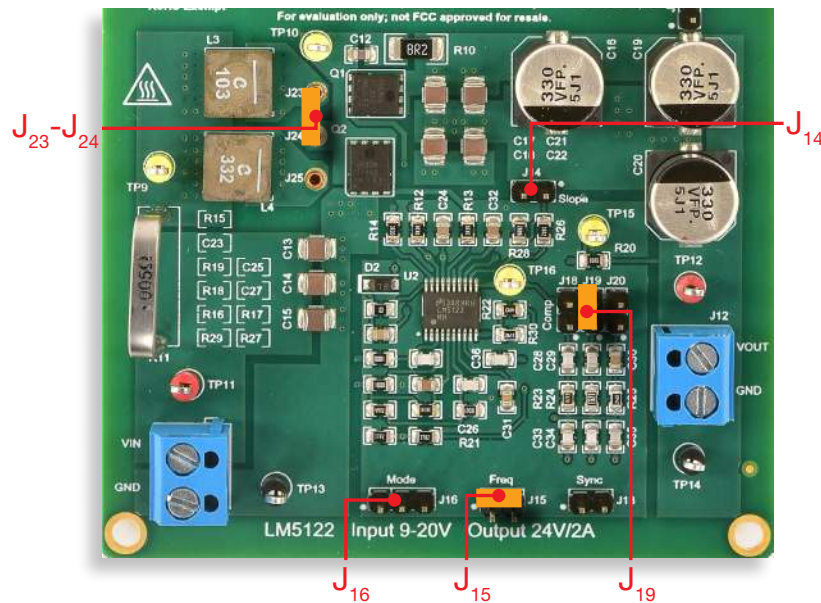

Figure 5. LM5122 board: jumpers set-up for Test#1

Initial jumpers set-up (see Figure 5):

- J_{13} open → no external synchronization signal connected
- J_{14} open → low slope current mode compensation
- J_{15} shorted → switching frequency $f_s = 500\text{kHz}$
- J_{16} open → DEM setup (change to J_{16} shorted left → SOM setup, according to *Measure and Calculate* section instructions)
- J_{18} open, J_{19} shorted, J_{20} open → error amplifier gain setup with parts R_{24} , C_{29} , C_{34} connected
- $J_{23} - J_{24}$ shorted → L_3 ($10\mu\text{H}$) inductor connected

Test Procedure:

- 1) turn on the MULTIMETERS, set the ICM and the OCM in DC CURRENT MODE, set the IVM and the OVM in DC VOLTAGE MODE
- 2) turn on the OSCILLOSCOPE, set the CH-1 in DC 50Ω coupling mode, set the CH-2 in DC $1\text{M}\Omega$ coupling mode, select CH-2 as trigger source, and execute the “de-gauss” of the current probe to remove possible dc bias in the current probe
- 3) turn on the POWER SUPPLY (ensure that the OUT ON button is OFF), set the voltage at the initial value of 10V, and set the CURRENT LIMIT $> 3\text{A}$
- 4) turn on the ELECTRONIC LOAD (ensure that the LOAD ON button is OFF), set the CONSTANT CURRENT MODE, and set the current at 0.2A
- 5) turn ON the POWER SUPPLY “OUT ON” button and adjust the DC POWER SUPPLY knob until you read 10V in the IVM display. In these conditions you should read about 24V in the OVM display, 0A in the OCM display and a very small positive value in the ICM display (if you do read values different than as described above, turn OFF the “OUT ON” button of the DC POWER SUPPLY and verify the previous steps)
- 6) turn ON the ELECTRONIC LOAD ON button and adjust the DC POWER SUPPLY knob until you read 10V in the IVM display. In these conditions you should read about 24V in the OVM display, 0.2A in the OCM display, about 0.5A in the ICM display, and see a triangular waveshape with about 0.5A average value on CH-1 of the OSCILLOSCOPE and a waveform swinging between 24V and a slightly negative value on CH-2 of the OSCILLOSCOPE (if the values are much different than the ones listed above, turn OFF the “LOAD ON” button of the ELECTRONIC LOAD and the “OUT ON” button of the DC POWER SUPPLY and verify the experiment setup)
- 7) read the input voltage value on the IVM display, the output voltage value on the OVM display, the input current value on the ICM display, the output current value on the OCM display, measure peak and valley values of the inductor current on CH-1 of the OSCILLOSCOPE, measure the frequency and duty-cycle of the switching node voltage on CH-2 of the OSCILLOSCOPE, detect the operation mode (CCM/DCM) and use the measured values according to *Measure and Calculate* section instructions. Repeat this step for all the load current and input voltage values listed in Table 1 (you do not need to turn OFF the POWER SUPPLY “OUT ON” button and the ELECTRONIC LOAD “LOAD ON” button while changing the input voltage and the load current)
- 8) turn OFF the “LOAD ON” button of the ELECTRONIC LOAD and the “OUT ON” button of the DC POWER SUPPLY, open the jumper J_{16} to setup LM5122 DEM operation and repeat steps from 3) to 7)
- 9) at the end of the measurements, turn OFF the “LOAD ON” button of the ELECTRONIC LOAD and the “OUT ON” button of the DC POWER SUPPLY, then switch off all the instruments.



Test#1: measure and calculate

For the operating conditions indicated in Table 1:

- 1) measure the average input voltage V_{in} , input current I_{in} , output voltage V_{out} and output current I_{out} , the switching frequency f_s , the duty-cycle D , the peak and valley values I_{pk} and I_{vl} of the inductor current
- 2) assess whether the regulator operates in CCM or DCM by observing the inductor current (in CCM operation the valley current I_{vl} at the beginning of the switching cycle is positive) (see also [Experiment 1](#))
- 3) based on the CCM/DCM assessment, and on the DEM/SOM setup, use the appropriate formulae provided in the [Theory Background](#) section to calculate the total power losses of the inductor and of the MOSFETs (P^{SY} with SOM setup and P^{DE} DEM setup), then calculate the experimental total power losses $P_{dexp} = V_{in} I_{in} - V_{out} I_{out}$ and fill the Table 1 cells.

Table 1. Efficiency of the boost converter operating at switching frequency $f_s = 500\text{kHz}$, with $L = 10\mu\text{H}$, at different line voltage and load current, in DEM and SOM setup

(1) exp. tot. losses [mW]	(2) calc. losses [mW]	DEM setup (J_{16} open)						SOM setup (J_{16} shorted left)					
		$I_{out}=0.2\text{A}$		$I_{out}=0.4\text{A}$		$I_{out}=0.8\text{A}$		$I_{out}=0.2\text{A}$		$I_{out}=0.4\text{A}$		$I_{out}=0.8\text{A}$	
$V_{in}=10\text{V}$		(1)	(2)	(1)	(2)	(1)	(2)	(1)	(2)	(1)	(2)	(1)	(2)
$V_{in}=16\text{V}$		(1)	(2)	(1)	(2)	(1)	(2)	(1)	(2)	(1)	(2)	(1)	(2)

Inductor:

$$J_{23}\text{-}J_{24} \text{ sh} \rightarrow L=L_3 = 10\mu\text{H}, \text{ESR}_L = 57\text{m}\Omega$$

$$c_1 = 1.81 \cdot 10^8, c_2 = 5.34 \cdot 10^5, c_3 = 1.28 \cdot 10^4, c_4 = 1.59 \cdot 10^{-9}, c_5 = 376.79$$

$$J_{24}\text{-}J_{25} \text{ sh} \rightarrow L=L_4 = 3.3\mu\text{H}, \text{ESR}_L = 19.5\text{m}\Omega,$$

$$c_1 = 1.81 \cdot 10^8, c_2 = 5.34 \cdot 10^5, c_3 = 1.28 \cdot 10^4, c_4 = 1.59 \cdot 10^{-9}, c_5 = 215.96$$

MOSFETs gate driver (LM5122):

$$V_{dr} = 7.6\text{V} \text{ (min } 6.9\text{V, max } 8.3\text{V)}$$

$$R_{Q1,up} = 2.4\Omega, R_{Q1,down} = 1.8\Omega$$

$$R_{Q2,up} = 2.5\Omega, R_{Q2,down} = 1.7\Omega$$

MOSFETs Q_1 and Q_2 :

$$R_{ds} = 12\text{m}\Omega(25^\circ\text{C}), 18\text{m}\Omega(125^\circ\text{C}), Q_{gs} = 4.5\text{nC},$$

$$Q_g = 11.5\text{nC}, Q_{rr} = 54\text{nC}, V_{th} = 3\text{V}(25^\circ\text{C}), 2.3\text{V}(125^\circ\text{C}),$$

$$R_{gint} = 5.5\Omega(\text{typ.}), 11\Omega(\text{max.}), g_{FS} = 60\text{S}(25^\circ\text{C}), 50\text{S}(125^\circ\text{C}),$$

$$C_{oss} = 177\text{pF}, t_{dt} = 80\text{ns}, V_{SD} = 1\text{V}$$

Answer:

1 Are the losses at low load with DEM setup higher than with SOM setup?

- yes
 no
 it depends on line voltage
 it depends on load current
 other: _____

2 How do the losses change while the input voltage increases?

- they increase
 they decrease
 it depends on load current
 it depends on CCM/DCM operation
 other: _____

3 How do the losses change while the load current increases?

- they increase
 they decrease
 it depends on line voltage
 it depends on CCM/DCM operation
 other: _____



Test#2: preparation and procedure

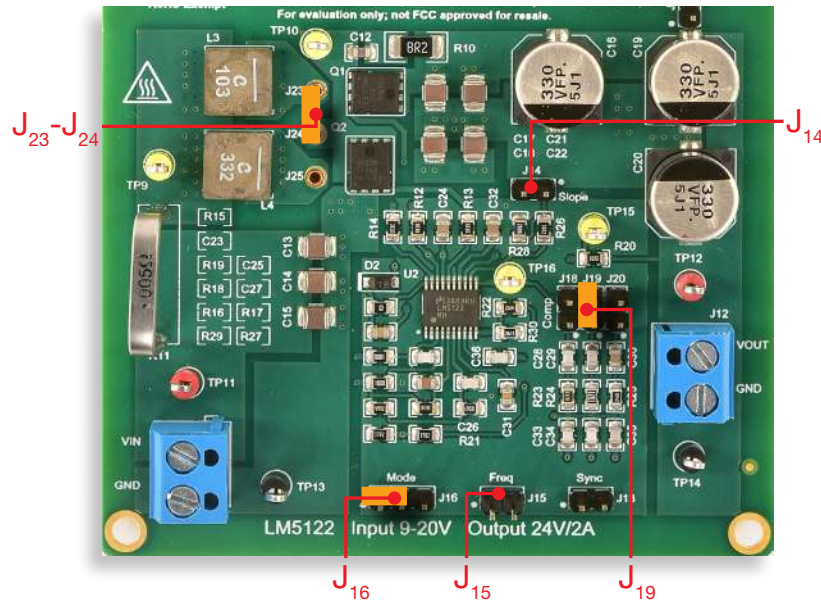

Figure 6. LM5122 board: jumpers set-up for Test#2

Initial jumpers set-up (see Figure 6):

- J_{13} open \rightarrow no external synchronization signal connected
- J_{14} open \rightarrow low slope current mode compensation
- J_{15} open \rightarrow switching frequency $f_s = 250\text{kHz}$
- J_{16} shorted left \rightarrow SOM setup
- J_{18} open, J_{19} shorted, J_{20} open \rightarrow error amplifier gain setup with parts R_{24} , C_{29} , C_{34} connected
- $J_{23} - J_{24}$ shorted $\rightarrow L_3$ ($10\mu\text{H}$) inductor connected

Test Procedure:

- 1) turn on the MULTIMETERS, set the ICM and the OCM in DC CURRENT MODE, set the IVM and the OVM in DC VOLTAGE MODE
- 2) turn on the OSCILLOSCOPE, set the CH-1 in DC 50Ω coupling mode, set the CH-2 in DC $1\text{M}\Omega$ coupling mode, select CH-2 as trigger source, and execute the “de-gauss” of the current probe to remove possible dc bias in the current probe
- 3) turn on the POWER SUPPLY (ensure that the OUT ON button is OFF), set the voltage at the initial value of 10V, and set the CURRENT LIMIT $> 3\text{A}$
- 4) turn on the ELECTRONIC LOAD (ensure that the LOAD ON button is OFF), set the CONSTANT CURRENT MODE, and set the current at 0.2A
- 5) turn ON the POWER SUPPLY “OUT ON” button and adjust the DC POWER SUPPLY knob until you read 10V in the IVM display. In these conditions you should read about 24V in the OVM display, 0A in the OCM display and a very small positive value in the ICM display (if you do read values different than as described above, turn OFF the “OUT ON” button of the DC POWER SUPPLY and verify the previous steps)
- 6) turn ON the ELECTRONIC LOAD ON button and adjust the DC POWER SUPPLY knob until you read 10V in the IVM display. In these conditions you should read about 24V in the OVM display, 0.2A in the OCM display, about 0.5A in the ICM display, and see a triangular waveshape with about 0.5A average value on CH-1 of the OSCILLOSCOPE and a waveform swinging between 24V and a slightly negative value on CH-2 of the OSCILLOSCOPE (if the values are much different than the ones listed above, turn OFF the “LOAD ON” button of the ELECTRONIC LOAD and the “OUT ON” button of the DC POWER SUPPLY and verify the experiment setup)
- 7) read the input voltage value on the IVM display, the output voltage value on the OVM display, the input current value on the ICM display, the output current value on the OCM display, measure peak and valley values of the inductor current on CH-1 of the OSCILLOSCOPE, measure the frequency and duty-cycle of the switching node voltage on CH-2 of the OSCILLOSCOPE, detect the value of the valley inductor current I_{v1} and use the measured values according to *Measure and Calculate* section instructions. Repeat this step for all the load current and input voltage values listed in Table 2 (you do not need to turn OFF the POWER SUPPLY “OUT ON” button and the ELECTRONIC LOAD “LOAD ON” button while changing the input voltage and the load current)
- 8) turn OFF the “LOAD ON” button of the ELECTRONIC LOAD and the “OUT ON” button of the DC POWER SUPPLY, short the jumper J_{15} to setup the switching frequency $f_s = 500\text{kHz}$ and repeat steps from 3) to 7)
- 9) at the end of the measurements, turn OFF the “LOAD ON” button of the ELECTRONIC LOAD and the “OUT ON” button of the DC POWER SUPPLY, then switch off all the instruments.



Test#2: measure and calculate

For the operating conditions of Table 2:

- 1) Measure the average input voltage V_{in} , input current I_{in} , output voltage V_{out} and output current I_{out} , the switching frequency f_s , the duty-cycle D , the peak and valley values I_{pk} and I_{vl} of the inductor current
- 2) Use the formulae provided in the *Theory Background* section to calculate the inductor conduction losses and core losses (formulae (5) and (6) when $I_{vl}>0$, formulae (19) and (6) when $I_{vl}<0$) and the MOSFETs conduction and switching losses (formulae (7), (8) and (13) when $I_{vl}>0$, formulae (20), (21), (22) and (23) when $I_{vl}<0$), and write the results in cells (1), (2), (3) and (4) of Table 2
- 3) Calculate the experimental total power losses $P_{exp} = P_{in} - P_{out} = V_{in}I_{in} - V_{out}I_{out}$, calculate the efficiency $\eta_{exp} = P_{out}/(P_{out}+P_{exp})$ and report the result in cell (5) of Table 2.

Table 2. Efficiency of the boost converter with SOM setup, at $V_{in} = 10V$ and $V_{in} = 20V$, with $f_s = 250kHz$ and $f_s = 500kHz$

Ind. Cond. [mW] (1)	Ind. Core [mW] (2)	FET Cond. [mW] (3)	FET Swit. [mW] (4)	η [%] (5)	Load current																								
					$I_{out}=0.2A$					$I_{out}=0.4A$					$I_{out}=0.6A$					$I_{out}=0.8A$					$I_{out}=1.0A$				
250kHz	$V_{in} = 10V$				(1)	(2)	(3)	(4)	(5)	(1)	(2)	(3)	(4)	(5)	(1)	(2)	(3)	(4)	(5)	(1)	(2)	(3)	(4)	(5)	(1)	(2)	(3)	(4)	(5)
	$V_{in} = 20V$				(1)	(2)	(3)	(4)	(5)	(1)	(2)	(3)	(4)	(5)	(1)	(2)	(3)	(4)	(5)	(1)	(2)	(3)	(4)	(5)	(1)	(2)	(3)	(4)	(5)
500kHz	$V_{in} = 10V$				(1)	(2)	(3)	(4)	(5)	(1)	(2)	(3)	(4)	(5)	(1)	(2)	(3)	(4)	(5)	(1)	(2)	(3)	(4)	(5)	(1)	(2)	(3)	(4)	(5)
	$V_{in} = 20V$				(1)	(2)	(3)	(4)	(5)	(1)	(2)	(3)	(4)	(5)	(1)	(2)	(3)	(4)	(5)	(1)	(2)	(3)	(4)	(5)	(1)	(2)	(3)	(4)	(5)

Inductor:

$J_{23}-J_{24}$ sh $\rightarrow L = 10\mu H$, $ESR_L = 57m\Omega$
 $c_1 = 1.81 \cdot 10^9$, $c_2 = 5.34 \cdot 10^5$, $c_3 = 1.28 \cdot 10^4$, $c_4 = 1.59 \cdot 10^{-9}$, $c_5 = 376.79$
 $J_{24}-J_{25}$ sh $\rightarrow L = 3.3\mu H$, $ESR_L = 19.5m\Omega$,
 $c_1 = 1.81 \cdot 10^9$, $c_2 = 5.34 \cdot 10^5$, $c_3 = 1.28 \cdot 10^4$, $c_4 = 1.59 \cdot 10^{-9}$, $c_5 = 215.96$

MOSFETs gate driver (LM5122):

$V_{dr} = 7.6V$ (min 6.9V, max 8.3V)
 $R_{Q1,up} = 2.4\Omega$, $R_{Q1,down} = 1.8\Omega$
 $R_{Q2,up} = 2.5\Omega$, $R_{Q2,down} = 1.7\Omega$

MOSFETs Q_1 and Q_2 :

$R_{ds} = 12m\Omega(25^\circ C), 18m\Omega(125^\circ C)$, $Q_{gsw} = 4.5nC$,
 $Q_g = 11.5nC$, $Q_{rr} = 54nC$, $V_{th} = 3V(25^\circ C), 2.3V(125^\circ C)$,
 $R_{gint} = 5.5\Omega(\text{typ.}), 11\Omega(\text{max.})$, $g_{FS} = 60S(25^\circ C), 50S(125^\circ C)$,
 $C_{oss} = 177pF$, $t_{dt} = 80ns$, $V_{SD} = 1V$

Answer:

- 1) How do the calculated inductor and MOSFETs losses change while the switching frequency increases?

inductor, conduction: they increase they decrease it depends on the load current
 MOSFETs, conduction: they increase they decrease it depends on the load current
 inductor, core: they increase they decrease it depends on the load current
 MOSFETs, switching: they increase they decrease it depends on the load current

it depends on the input voltage
 it depends on the input voltage
 it depends on the input voltage
 it depends on the input voltage

- 2) How do the total MOSFET+inductor calculated losses change while the switching frequency increases?

they increase they decrease it depends on the load current

it depends on the input voltage

- 3) How does the measured efficiency change while the switching frequency increases?

it increases it decreases it depends on the load current

it depends on the input voltage



Discussion

In Test#1 we are interested in measuring the power losses of the boost regulator while varying the input voltage and the load current.

The *Theory Background* section highlights that the power loss of the boost depends on the input voltage V_{in} , the switching frequency f_s , the load current, and the inductance L . With DEM setup the boost converter operates with the body diode of the MOSFET Q_1 as a freewheeling diode, and then it can operate in DCM or in CCM depending on the load current. In particular, the DCM can be observed when the load current I_{out} is lower than the value of the threshold current I_{dcm} given by equation (1) of the *Theory Background* section. With SOM setup, instead, the boost converter operates in CCM for whatever load current, as the MOSFET Q_1 can sustain negative currents when it is ON. With SOM setup, when the load current is lower than the threshold current I_{dcm} , the valley current I_{vi} at the beginning of the switching cycle, where the MOSFET Q_1 turns OFF and the MOSFET Q_2 turns ON, is negative ($I_{vi} < 0$) and this causes a change in the conduction and switching losses of both MOSFETs. Therefore, as highlighted in *Theory Background* section, we have four possible operation mode combinations one involving the DCM: DEM with $I_{out} > I_{dcm}$ (CCM), DEM with $I_{out} < I_{dcm}$ (DCM), SOM with $I_{out} > I_{dcm}$ (CCM), SOM with $I_{out} < I_{dcm}$ (CCM). The DCM influences the shape of the inductor current, which remains at zero during the *dead interval* (see the discussion of *Experiment 1* on the real behavior of inductor current and switching node voltage in DCM), whereas there is no *dead interval* in CCM. This is why we have the two different formulae for inductor winding losses (5) and (19) for CCM and DCM respectively. The conduction and switching losses of MOSFETs are also different when the boost converters operates in DCM. In fact, due to the different values of peak and valley of the inductor currents I_{pk} and I_{vp} , the rms currents change, and the turn ON commutation of MOSFET Q_2 changes too, as it occurs at zero current with consequent zero losses. When the load current I_{out} is higher than the value of the threshold current I_{dcm} , the inductor current waveforms with DEM and SOM setup are the same. However, the conduction losses are different because with DEM setup the body diode of the MOSFET Q_1 conducts during the entire interval from the turn OFF of the MOSFET Q_2 to its following turn ON, whereas with SOM setup it conducts only during the short dead time t_{dt} needed to avoid the cross-conduction of the two MOSFETs.

In Test#2 we are interested in analyzing the impact of the switching frequency on inductor and MOSFETs losses and on the efficiency of the boost regulator while varying the load current.

The SOM is preferred in dc-dc converters operating with high load current, as it facilitates the achievement of higher efficiency, thanks to the reduced conduction losses of power MOSFETs compared to diodes. The boost regulator with SOM setup operates in CCM, regardless of whether the load current I_{out} is lower or higher than the value of the threshold current I_{dcm} given by equation (1) of the *Theory Background* section (see *Experiment 1* to further investigate the operation in DCM). Nevertheless, the operation with a load current lower than the threshold current I_{dcm} (which involves $I_{vi} < 0$) determines different losses in the two MOSFETs and in the inductor, which are the devices determining the main contributions to the converter power losses. The MOSFETs and inductor conduction losses increase as the square of the rms current are proportional to the drain-to-source resistance in the MOSFETs and to the winding resistance in the inductor. Conduction losses formulae (5), (7) and (8) are valid when $I_{vi} > 0$ ($I_{out} > I_{dcm}$), whereas the formulae (19), (20) and (21) are valid when $I_{vi} < 0$ ($I_{out} < I_{dcm}$). The formulae for the calculation of MOSFETs switching losses when $I_{vi} < 0$ are different than the ones provided for the case $I_{vi} > 0$ too, although the boost regulator operates in CCM in both situations. The MOSFETs switching losses occur during the turn ON and during the turn OFF, while the devices transit through the saturation region, where they sink the power $V_{ds} \times I_{ds}$. MOSFETs switching losses are given by the formula (13) when $I_{vi} > 0$ ($I_{out} > I_{dcm}$), whereas the formula (22) is valid when $I_{vi} < 0$ ($I_{out} < I_{dcm}$). When $I_{vi} > 0$, the switching losses are mostly determined by the turn ON and the turn OFF of the MOSFET Q_2 in *hard-switching* mode (formula (13)), namely with drain-to-source voltage $V_{ds} \neq 0$ and current $I_{ds} \neq 0$ at the instant of commutation and with a large swing of the V_{ds} voltage from V_{out} to zero at the turn ON and from zero to V_{ds} at the turn OFF. The MOSFET Q_1 , instead, turns ON and OFF in *soft-switching* mode, while its body diode conducts, thus clamping the V_{ds} voltage to its forward voltage value (about 1V) during the commutations. This reduces dramatically the switching losses (this is why they are neglected). When $I_{vi} < 0$, the switching losses are determined by both MOSFETs at their turn OFF in *hard-switching* mode (formula (22)), whereas both MOSFETs turn ON in *soft-switching* mode, with very small losses, as such commutation occurs while their own body diode are conducting, respectively. The simple rule to assess whether a MOSFET is turning ON or OFF in *hard-switching* or in *soft-switching* is that the commutation occurs in *hard-switching* if the drain-to-source current I_{ds} at the moment of the commutation is positive, and in *soft-switching* if the drain-to-source current I_{ds} is negative. Overall, the MOSFETs switching losses are proportional to the switching frequency, as the amount of energy lost because of switching losses per each switching period is fixed, and then the average switching losses increase with the switching frequency. Inductor core losses are determined by the hysteresis and by the eddy currents phenomena affecting the magnetic core, and are given by the formula (6). While the MOSFETs switching losses can be quite easily determined from physical models, which lead to the relevant loss formulae referred above, the inductor core losses formulae are determined experimentally by the manufacturers, through a curve fitting of experimental measurements of power losses. Inductor core losses may depend on the switching frequency in a quite involved way (note that the γ factor in formula (6) is proportional to the peak-to-peak ripple Δi_{pp} and then inversely proportional to the switching frequency).



Experimental plots

The plots collected in the Figures 7 to 10 show the waveforms of the boost converter in CCM and DCM operation.

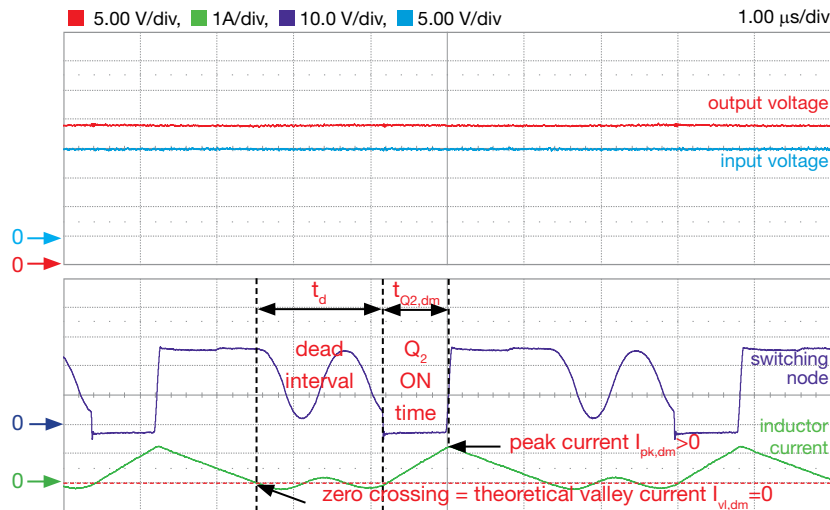

Figure 7. DCM operation with DEM setup:
 $V_{in} = 15V$, $I_{out} = 0.2A$, nominal $f_s = 250kHz$ (real $f_s = 265kHz$), $L = 10\mu H$

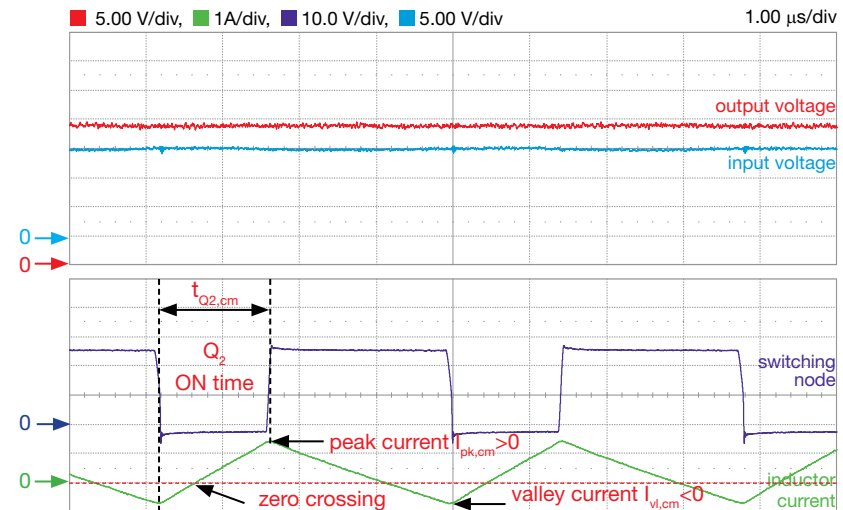

Figure 8. CCM operation with SOM setup:
 $V_{in} = 15V$, $I_{out} = 0.2A$, nominal $f_s = 250kHz$ (real $f_s = 265kHz$), $L = 10\mu H$

The plot of Figure 7 shows the DCM operation at low load current determined by the DEM setup. In theory, the valley current $I_{vl,dm}$ should be zero. Due to the oscillations caused by the resonance between the MOSFETs parasitic capacitances and the inductor, during the dead interval the inductor current swings around zero. This determines a slight increase of inductor conduction and core losses. Figure 8 shows the CCM operation, in the same test conditions of Figure 7, determined by the SOM setup. Now, there is no dead interval and the inductor current waveform is purely triangular, with a negative valley current $I_{vl,cm}$. You can observe that the peak inductor currents $I_{pk,dm}$ and $I_{pk,cm}$ and the MOSFET Q_2 ON times $t_{Q2,dm}$ and $t_{Q2,cm}$ are different.

[NOTE: the real switching frequency is about 265kHz. This is the value to be used in the theoretical power loss formulae provided the *Theory Background* section to calculate the inductor core losses and the MOSFETs switching losses].



Experimental plots

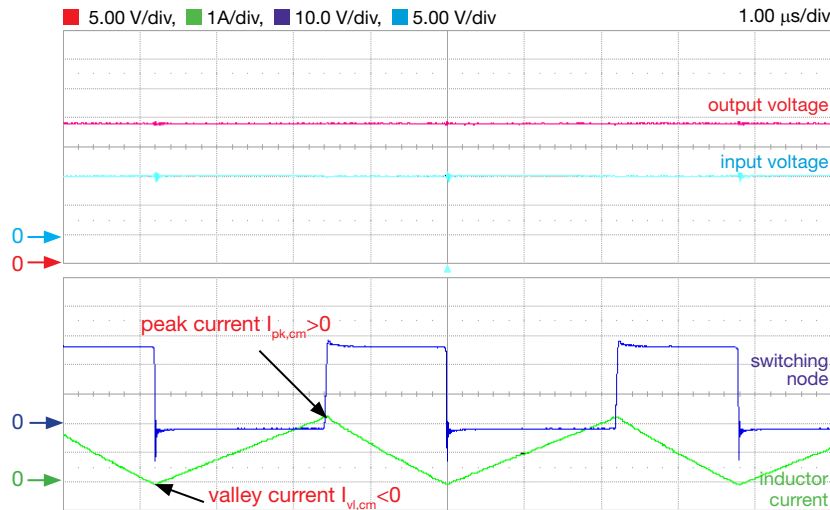

Figure 9. Boost converter operation with SOM setup at low load ($I_{out} < I_{dcm}$):
 $V_{in}=10V$, $I_{out}=0.4A$, nominal $f_s=250kHz$ (real $f_s=265kHz$), $L=10\mu H$

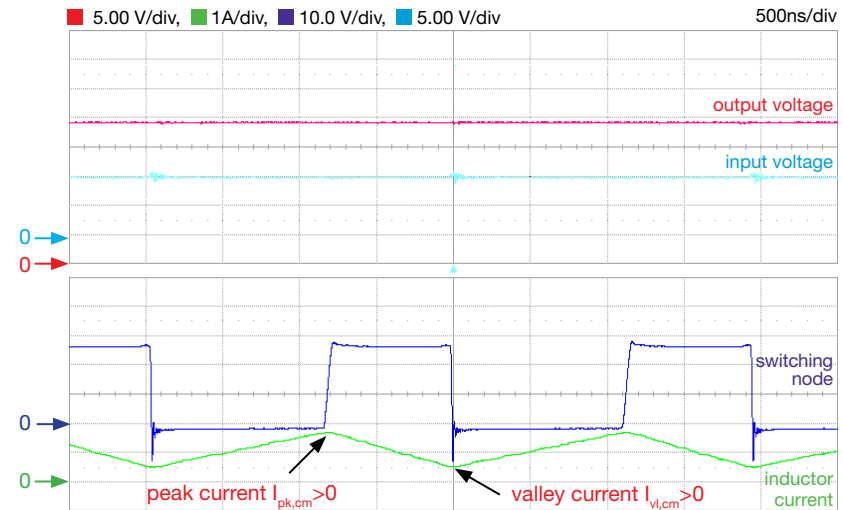

Figure 10. Boost converter operation with SOM setup at high load ($I_{out} > I_{dcm}$):
 $V_{in}=10V$, $I_{out}=0.4A$, nominal $f_s=500kHz$ (real $f_s=513kHz$), $L=10\mu H$

The plots of Figures 9 and 10 show the impact of the switching frequency on the inductor current waveform. Doubling the switching frequency reduces the inductor peak-to-peak ripple current of about 50% and makes the valley current I_{vl} positive. It is expected that the effects of the higher magnitude of the peak-to-peak inductor current ripple of Figure 9 on the inductor core losses can be balanced by the effects of the lower switching frequency, based on the loss formula (6) provided in the *Theory Background* section. It is also expected that in case of Figure 9 the turn ON losses of MOSFET Q_2 are negligible, as it commutates in soft-switching mode, and that the turn OFF losses of the MOSFET Q_1 are also small, despite of the hard-switching commutation, due to the small magnitude of the inductor current at the instant of commutation. In the case of Figure 10, instead, the switching losses are concentrated in the MOSFET Q_2 , as both its commutations are in *hard-switching* mode.

[NOTE: the real switching frequency values are about 265kHz and 513kHz, in Figures 9 and 10 respectively. These are the values to be used in the theoretical power loss formulae provided in the *Theory Background* section to calculate the inductor core losses and the MOSFETs switching losses].

Experiment 3

The goal of this experiment is to analyze the influence of input voltage, load current and feedback compensation on the dynamic response of a current-mode controlled boost converter. The TPS55340 boost regulator is used for this experiment.



Case Study

The goal of this experiment is to analyze the influence of input voltage, load current and feedback compensation on the dynamic response of current-mode controlled boost converter.

The TI-PMLK TPS55340 boost regulator provides an output voltage $V_{out}=24V$, with an input voltage V_{in} from 5V to 12V⁽¹⁾, and a load current I_{out} up to 0.6A. Figure 1 shows the basic circuit schematic, where the devices highlighted are: the input capacitor (C_I), the inductor (L), the output capacitor (C_O), the Schottky diode (D_1), the feedback compensation (R_C, C_C, C_S) and the output voltage sensing (R_{SH}, R_{SL}).

The peak current mode control technique allows to achieve a good rejection to line and load perturbations. The response to line transients and load transient is influenced by the DC input voltage and load current operating conditions and by the peak current control setup. The current sensing resistance and the slope compensation for current loop stability are fixed internally in the TPS55340 controller. Voltage feedback compensation is instead fixed by the external parts R_C, C_C, C_S , whose values can be changed through the position of jumper J_{17} .

⁽¹⁾ Restricted range adopted for this educational board, compared to the 2.9V to 32V full range of TPS55340 [5]

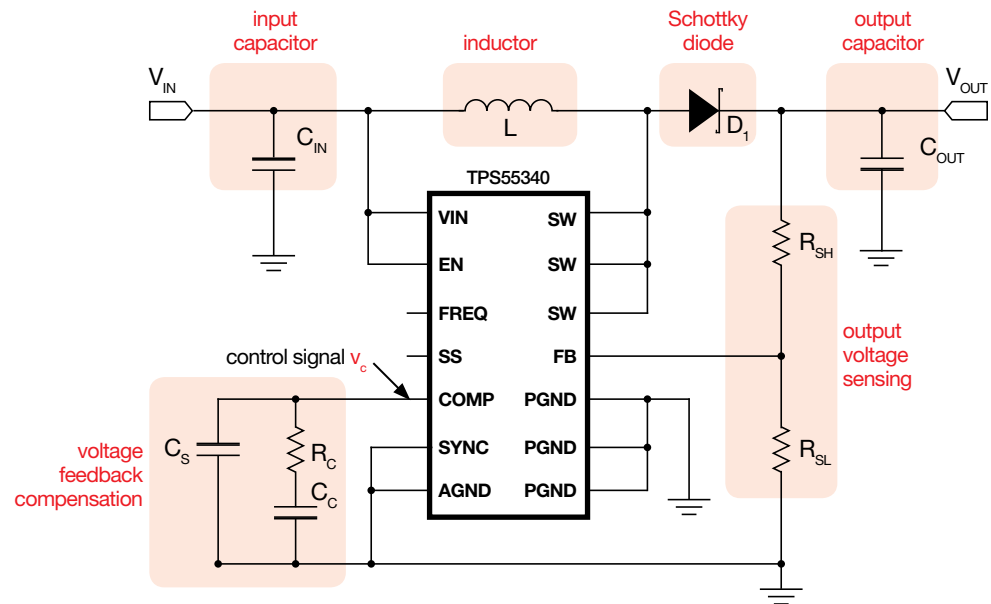

Figure 1. Simplified schematic of the TPS55340 Boost regulator

Test#1. We set-up the TPS55340 boost regulator with different input voltage values and observe the output voltage waveform as the load current swings between two fixed levels. The expectation is that, after each load current change, the output voltage has some transient surge and then it returns to the nominal value. The magnitude of the output voltage transient surges will be measured. The influence of the output capacitance C_{OUT} and of the feedback compensation setup on the magnitude of voltage transient surges will be observed and discussed.

Test#2. We set-up the TPS55340 boost regulator with different load current values and observe the output voltage waveform as the input voltage swings between two fixed levels. The expectation is that, after each input voltage change, the output voltage has some transient surge and then it returns to the nominal value. The magnitude of the output voltage transient surges will be measured. The influence of the output capacitance C_{OUT} and of the feedback compensation setup on the magnitude of voltage transient surges will be observed and discussed.



Theory Background

The fundamentals for the analysis of the peak current mode controlled boost converter dynamic response are summarized in the following equations. (see [1][2][3] and [6] for more details on boost topology operation, dynamic modeling and current-mode control analysis and design; see [5] for more details on TPS55340 operation and features)

Uncompensated Loop Gain

The control-to-output gain of peak-current-mode controlled boost converter is (1):

$$(1) G_{vc}(s) \cong G_{vc0} \frac{\left[1 + \frac{s}{\omega_{ESR}}\right] \left[1 - \frac{s}{\omega_{RHP}}\right]}{\left[1 + \frac{s}{\omega_{LFP}}\right] \left[1 + \frac{2s}{Q_s \omega_s} + \frac{4s^2}{\omega_s^2}\right]}$$

where $\omega_s = 2\pi f_s$ and:

$$(2) G_{vc0} = \frac{V_{in}}{2I_{out}R_s}; \omega_{ESR} = \frac{1}{ESR_{out}C_{out}};$$

$$(3) \omega_{RHP} = \frac{V_{in}^2}{V_{out}I_{out}L}; \omega_{LFP} = \frac{2I_{out}}{C_{out}V_{out}};$$

$$(4) Q_s = \frac{1}{\pi} \left[\frac{V_{in}}{V_{out}} \left(1 + \frac{s_e}{s_n}\right) - \frac{1}{2} \right]^{-1}$$

$$(5) s_e = K_0 + K_1 \frac{V_{out}}{V_{in}}; s_n = \frac{R_s V_{in}}{L} = K_2 V_{in}^{(1)}$$

⁽¹⁾ $K_0 = 8.3 \cdot 10^4$, $K_1 = 58f_s$, $R_s = 15m\Omega$ for TPS55340.

s_e is the slope of the current signal used by the controller to fix the duty-cycle D when it crosses the control signal, as shown in Figure 2. Stability is achieved for any V_{in} if $Q_s > 0$, i.e.:

$$(6) \frac{V_{out}}{2} - 2\sqrt{\frac{K_1 V_{out}}{K_2}} < K_0 < \frac{V_{out}}{2} + 2\sqrt{\frac{K_1 V_{out}}{K_2}}$$

Figure 3 shows how the DC gain G_{vc0} , the Low Frequency Pole ω_{LFP} , the Right Half Plane zero ω_{RHP} , and the sampling quality factor Q_s of peak-current-mode control change with V_{in} and I_{out} .

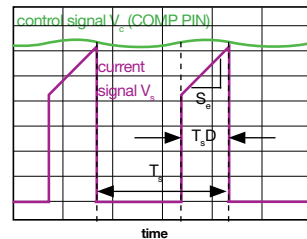

Figure 2

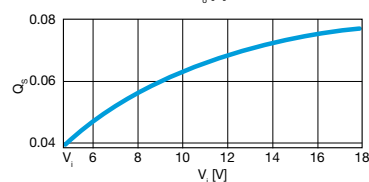
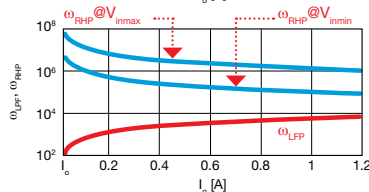
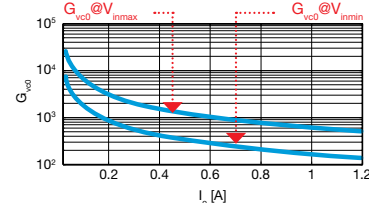

Figure 3

Error Amplifier Gain

Figure 4 shows the circuit setup of the TPS55340 Type II Error Amplifier (EA).

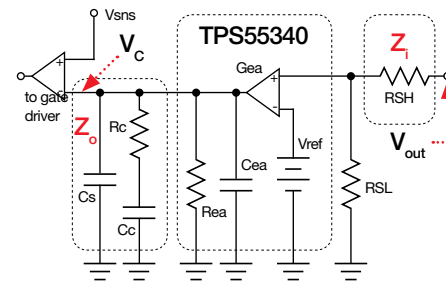

Figure 4

The EA gain $G_c(s)$ determines the compensated loop gain $T(s) = G_{vc}(s)G_c(s)$. For Type II EA it is:

$$(7) G_c(s) \cong G_{c0} \left[1 + \frac{s}{\omega_z}\right] \left[1 + \frac{s}{\omega_{p0}}\right]^{-1} \left[1 + \frac{s}{\omega_p}\right]^{-1}$$

$$(8) \frac{R_{SL}}{R_{SL} + R_{SH}} = H = \frac{V_{ref}}{V_{out}} \quad G_{c0} = R_{ea} G_{ea} H^{(2)}$$

$$(9) \omega_z = \frac{1}{R_c C_c} \quad \omega_{p0} \cong \frac{1}{R_{ea} (C_{ea} + C_c + C_s)^{(2)}$$

$$(10) \omega_p = \frac{1}{(R_c || R_{ea})(C_{ea} + C_s)}$$

⁽²⁾ $G_{ea} = 360\mu S$, $R_{ea} = 10M\Omega$, $C_{ea} = 2pF$ for TPS55340.

The parameters of the external impedances Z_1 (R_{SH}) and Z_0 (R_c , C_c , C_s) depend on the desired cross-over frequency ω_c and phase margin ϕ_c of the compensated loop gain $T(s)$, according to the following formulae [3]:

$$(11) C_c = \frac{K(\gamma_c \omega_c K - 1)}{R_{ea} \omega_c (K^2 + 1)} \quad C_s = \frac{\gamma_c}{R_{ea}} - C_c - C_{ea}$$

$$(12) R_c = \frac{K}{\omega_c C_c} \quad K = \tan\left[\frac{1}{2}\phi_b + 45^\circ\right]$$

$$(13) \gamma_c = \frac{1}{\omega_c} \sqrt{[|G_{vc}(\omega_c)| G_{c0} K]^2 - 1}$$

$$(14) \phi_b = \phi_c - 90^\circ - \angle G_{vc}(\omega_c)$$

$$(15) |G_{vc}(\omega_c)| = \text{magnitude of } G_{vc}(\omega) @ \omega = \omega_c$$

$$(16) \angle G_{vc}(\omega_c) = \text{phase of } G_{vc}(\omega) @ \omega = \omega_c$$

Figure 5 shows the Bode plots of the control-to-output G_{vc} gain at $V_{inmin} = 5V$ and $V_{inmax} = 12V$, and highlights the maximum cross-over frequency ω_{cmax} allowing the use of a Type II EA.

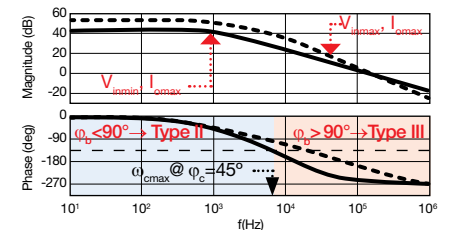

Figure 5

Good to Know

- The maximum cross-over frequency allowed by Type II EA, ω_{cmax} , is where $\phi_b = 90^\circ$. Beyond that limit a phase boost $\phi_b > 90^\circ$ is required and a Type III EA is needed, which is characterized by two zeros and two poles.
- R_{ea} limits the maximum DC gain $G_{vc0} G_{c0}$. C_{ea} limits the maximum cross-over frequency ω_c .



Experiment set-up: configuration

The instruments needed for this experiment are: a POWER SUPPLY with DC and DYNAMIC MODE options, an ELECTRONIC LOAD with DC and DYNAMIC MODE options and an OSCILLOSCOPE. Figure 5 shows the instruments connections. Follow the instructions provided in next page to set-up the **connections**.

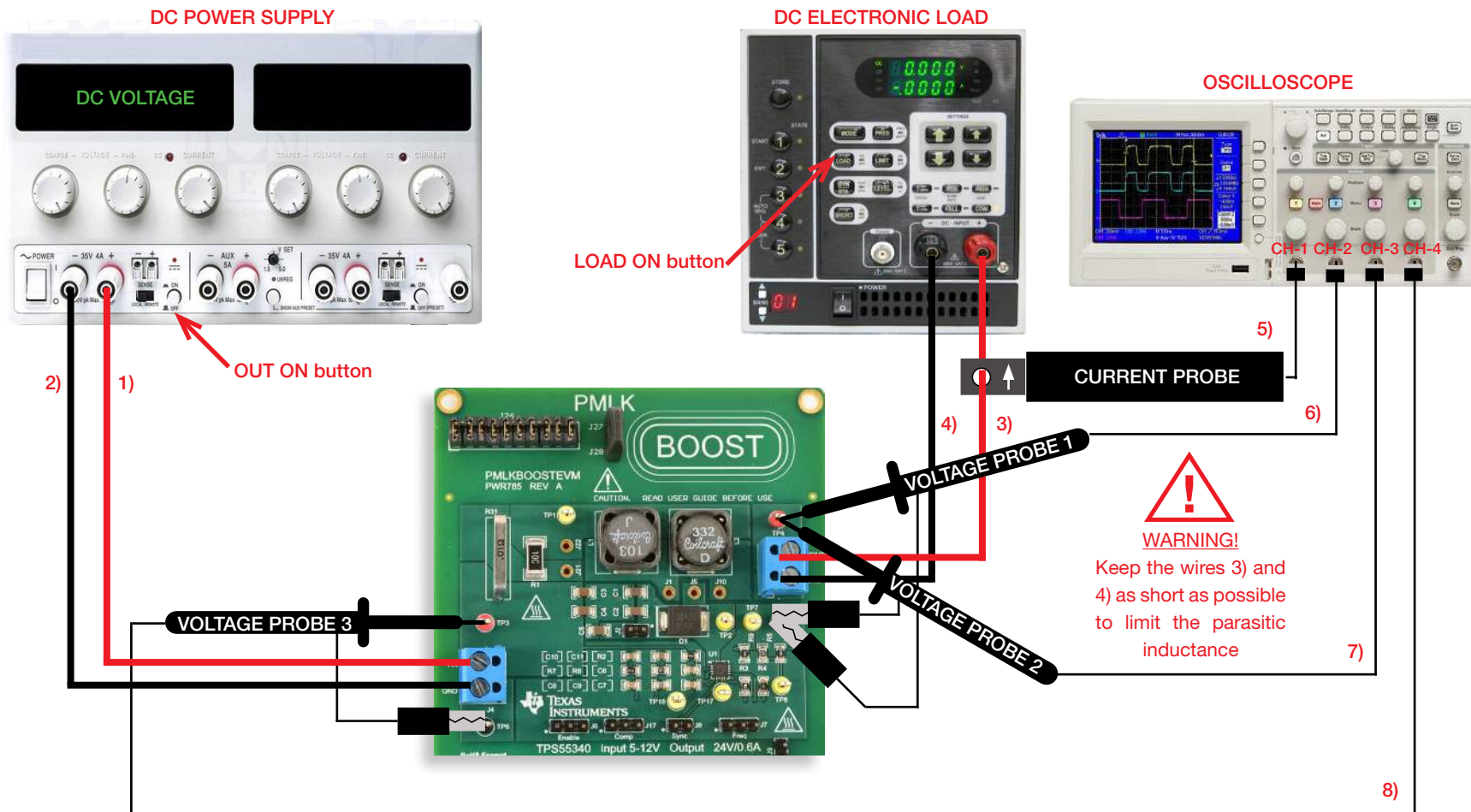

Figure 6. Experiment set-up.



Experiment set-up: instructions

With all the instruments turned off, make the following **connections**:

- 1) connect the POSITIVE (RED) OUTPUT of the DC POWER SUPPLY to the INPUT (VIN) of the J_4 screw terminal of the TPS55340 boost regulator
- 2) connect the NEGATIVE (BLACK) OUTPUT of the DC POWER SUPPLY to the GROUND (GND) of the J_4 screw terminal of the TPS55340 boost regulator
- 3) connect the OUTPUT (VOUT) of the J_3 screw terminal of the TPS55340 boost regulator to the POSITIVE (RED) INPUT of the ELECTRONIC LOAD
- 4) connect the GROUND (GND) of the J_3 screw terminal of the TPS55340 boost regulator to the NEGATIVE (BLACK) INPUT of the ELECTRONIC LOAD
- 5) connect a current probe to channel 1 of the OSCILLOSCOPE and hang it on the cable connecting the OUTPUT (VOUT) of the J_3 screw terminal of the TPS55340 boost regulator to the POSITIVE (RED) INPUT of the ELECTRONIC LOAD, ensuring that the arrow printed on the probe clamps corresponds to the current that enters the ELECTRONIC LOAD
- 6) connect a voltage probe to channel 2 of the OSCILLOSCOPE, hang its positive tip to TEST PIN TP_4 which is the output voltage of the TPS55340 boost regulator. This probe will be used to measure the DC+AC components of the output voltage
[WARNING: DO NOT INVERT the positive and ground connections of the voltage probe]
- 7) connect a voltage probe to channel 3 of the OSCILLOSCOPE, hang its positive tip to TEST PIN TP_4 which is the output voltage of the TPS55340 boost regulator. This probe will be used to measure the AC component of the output voltage
[WARNING: DO NOT INVERT the positive and ground connections of the voltage probe]
- 8) connect a voltage probe to channel 4 of the OSCILLOSCOPE, hang its positive tip to TEST PIN TP_3 which is the input voltage of the TPS55340 boost regulator
[WARNING: DO NOT INVERT the positive and ground connections of the voltage probe]



Test#1: preparation and procedure

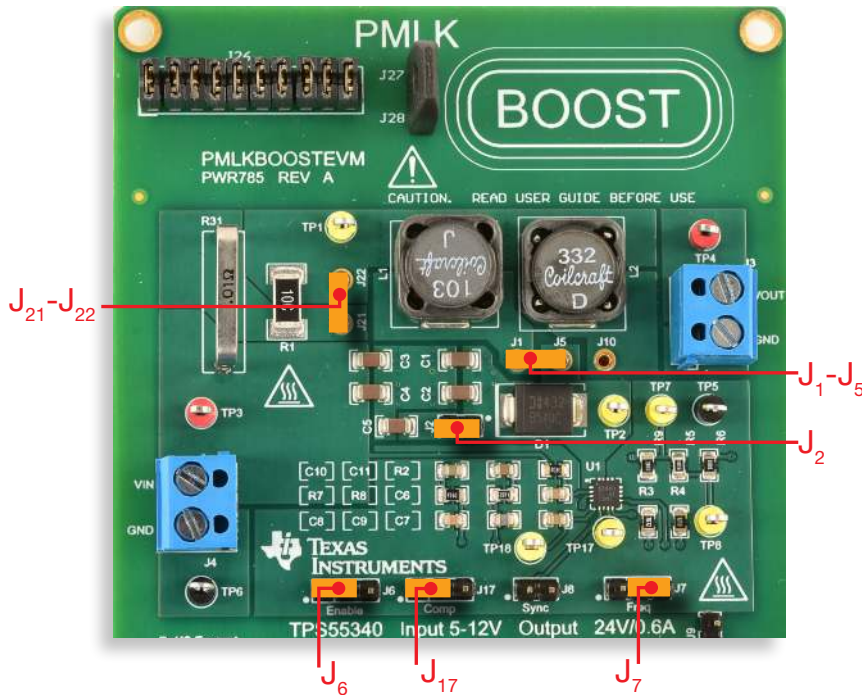

Figure 7. TPS55340 boost board: jumpers set-up for Test#1

Initial jumpers set-up (see Figure 7):

- J_6 shorted left → boost operation enabled
- J_2 shorted → C_5 (4.7 μ F) output capacitor connected
- J_7 shorted right → switching frequency $f_s = 400\text{kHz}$
- J_{17} shorted left → error amplifier gain setup with parts R_7 , C_8 , C_{10} connected (lower cross-over frequency)
- $J_1 - J_5$ shorted → L_1 (10 μ H) inductor connected
- $J_{21} - J_{22}$ shorted → loss emulation resistor R_1 bypassed
- J_8 open → boost operation with internal synchronization

Test Procedure:

- 1) turn on the OSCILLOSCOPE, set CH-1 in DC 50 Ω coupling mode, select CH-1 as trigger source, execute the “de-gauss” of the current probe to remove possible dc bias in the current probe, set CH-2 in DC 1M Ω coupling mode, CH-3 in AC 1M Ω coupling mode and CH-4 in DC 1M Ω coupling mode
- 2) turn on the POWER SUPPLY (ensure that the “OUT ON” button is OFF), set the DC VOLTAGE at 5V, and set the CURRENT LIMIT at 2.5A
- 3) turn on the ELECTRONIC LOAD (ensure that the “LOAD ON” button is OFF), set the DYNAMIC CURRENT MODE and fix the low current level at 200mA for 800 μ s, the high current level at 400mA for 800 μ s, the current rise and fall slew-rates at the highest level allowed by the instrument
- 4) turn ON the POWER SUPPLY “OUT ON” button. In these conditions you should see the load current on the CH-1 trace of the OSCILLOSCOPE as a flat waveform at zero level, the DC+AC components of the output voltage on the CH-2 trace as a flat waveform at 24V average value, the AC component of output voltage on CH-3 trace as a flat waveform at zero level, and the input voltage on CH-4 trace as a flat line at 5V level (if the waveforms do not look as described above, turn OFF the “OUT ON” button of the DC POWER SUPPLY and verify the previous steps)
- 5) turn ON the ELECTRONIC “LOAD ON” button. In these conditions you should see the load current on the CH-1 trace of the OSCILLOSCOPE as square-wave between 0.2A and 0.4A, the DC+AC components of the output voltage on the CH-2 trace as a waveform with 24V average value with small positive and negative surges at the instants of the load current steps, the AC component of output voltage on CH-3 trace as a flat waveform at zero level with small positive and negative surges at the instants of the load current steps, and the input voltage on CH-4 trace as a flat line at 5V level. (if the waveforms do not look as described above, turn OFF the “OUT ON” button of the DC POWER SUPPLY and verify the previous steps)
- 6) record in Table 1 the magnitude of the output voltage surges after each load transient for the input voltage values listed in Table 1 (you do not need to turn OFF the POWER SUPPLY “OUT ON” button while adjusting the input voltage)
- 7) turn OFF the “LOAD ON” button of the ELECTRONIC LOAD and the “OUT ON” button of the DC POWER SUPPLY, then open the jumper J_2 to disconnect the C_5 (4.7 μ F) output capacitor, repeat the steps 4) to 6), and report the results in Table 1
- 8) turn OFF the “LOAD ON” button of the ELECTRONIC LOAD and the “OUT ON” button of the DC POWER SUPPLY, then short the jumper J_{17} on right side to connect the R_8 , C_9 , C_{11} parts to the error amplifier, repeat the steps 4) to 6), and report the results in Table 1
- 9) at the end of the measurements, turn OFF the “LOAD ON” button of the ELECTRONIC LOAD and the “OUT ON” button of the DC POWER SUPPLY, then switch off all the instruments



Test#1: measure and calculate

For the operating conditions of Table 1, measure the peak output voltage overshoot and undershoot, with a dynamic load connected to the output.

Table 1. Load transient overshoot and undershoot magnitude of TPS55340 boost regulator at $f_s = 400\text{kHz}$ with $L = 10\mu\text{H}$ for different input voltage values

$C_{out} = 3 \times 4.7\mu\text{F}; R_7, C_8, C_{10}$ connected			$C_{out} = 2 \times 4.7\mu\text{F}; R_7, C_8, C_{10}$ connected			$C_{out} = 2 \times 4.7\mu\text{F}; R_8, C_9, C_{11}$ connected		
ΔV_{out}	I_{out} 0.2A→0.4A	I_{out} 0.4A→0.2A	ΔV_{out}	I_{out} 0.2A→0.4A	I_{out} 0.4A→0.2A	ΔV_{out}	I_{out} 0.2A→0.4A	I_{out} 0.4A→0.2A
$V_{in}=5\text{V}$			$V_{in}=5\text{V}$			$V_{in}=5\text{V}$		
$V_{in}=8\text{V}$			$V_{in}=8\text{V}$			$V_{in}=8\text{V}$		
$V_{in}=12\text{V}$			$V_{in}=12\text{V}$			$V_{in}=12\text{V}$		

Feedback compensation components:

J_{17} sh left: $R_c=R_7=976\Omega$, $C_c=C_{10}=150\text{nF}$, $C_s=C_8=68\text{nF}$ [$f_c=1.5\text{kHz}$, $\varphi_c=45^\circ$ @O.C.⁽⁵⁾]

J_{17} sh right: $R_c=R_8=2.37\text{k}\Omega$, $C_c=C_{11}=470\text{nF}$, $C_s=C_9=220\text{pF}$ [$f_c=6.5\text{kHz}$, $\varphi_c=45^\circ$ @O.C.⁽⁵⁾]

⁽⁵⁾ Operating Conditions (O.C.): $V_{in}=5\text{V}$, $I_{out}=1.2\text{A}$, $L=10\mu\text{H}$, $C_{out} = 3 \times 4.7\mu\text{F}$.

Inductor

J_1 - J_5 sh: $L=L_1=10\mu\text{H}$

J_5 - J_{10} sh: $L=L_2=3.3\mu\text{H}$

Output capacitor:

J_2 op: $C_{out}=2 \times 4.7\mu\text{F}$

J_2 sh: $C_{out}=3 \times 4.7\mu\text{F}$

Answer:

- Is the load transient voltage overshoot magnitude bigger than the undershoot magnitude? yes no it depends on line voltage
- Is the load transient response characterized by oscillations? yes no it depends on line voltage
- How does the load transient surge magnitude change when the line voltage increases? it increases with voltage it decreases with voltage it is not correlated
- What is the factor determining the strongest change in the load transient surge magnitude? the output capacitor the compensation they are equivalent



Test#2: preparation and procedure

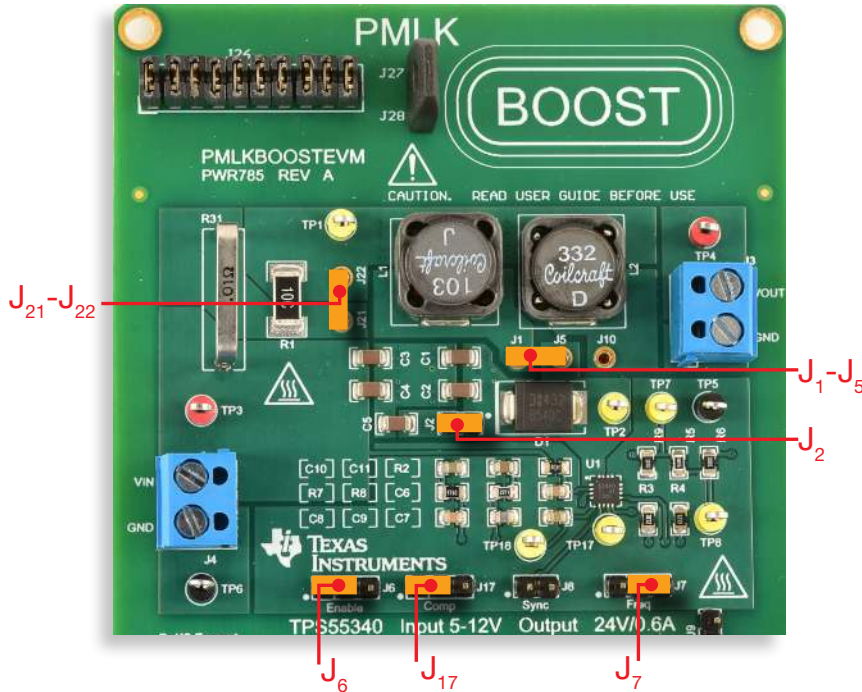

Figure 8. TPS55340 boost board: jumpers set-up for Test#2

Initial jumpers set-up (see Figure 8):

- J_6 shorted left → boost operation enabled
- J_2 shorted → C_5 (4.7 μ F) output capacitor connected
- J_7 shorted right → switching frequency $f_s = 400\text{kHz}$
- J_{17} shorted left → error amplifier gain setup with parts R_7 , C_8 , C_{10} connected (lower cross-over frequency)
- $J_1 - J_5$ shorted → L_1 (10 μ H) inductor connected
- $J_{21} - J_{22}$ shorted → loss emulation resistor R_1 bypassed
- J_8 open → boost operation with internal synchronization

Test Procedure:

- 1) turn on the OSCILLOSCOPE, set CH-1 in DC 50 Ω coupling mode, select CH-1 as trigger source, execute the “de-gauss” of the current probe to remove possible dc bias in the current probe, set CH-2 in DC 1M Ω coupling mode, CH-3 in AC 1M Ω coupling mode and CH-4 in DC 1M Ω coupling mode
- 2) turn on the POWER SUPPLY (ensure that the “OUT ON” button is OFF), set the DYNAMIC MODE, fix the low voltage level at 5V for 800 μ s, the high voltage level at 12V for 800 μ s, the voltage rise and fall slew-rates at the highest level allowed by the instrument, the CURRENT LIMIT at 3.5A
- 3) turn on the ELECTRONIC LOAD (ensure that the “LOAD ON” button is OFF), set the DC CURRENT MODE and current level at 200mA
- 4) turn ON the POWER SUPPLY “OUT ON” button. In these conditions you should see the load current on the CH-1 trace of the OSCILLOSCOPE as a flat waveform at zero level, the DC+AC components of the output voltage on the CH-2 trace as a flat waveform at 24V average value with small positive and negative surges at the instants of the line voltage steps, the AC component of output voltage on CH-3 trace as a flat waveform at zero level with small positive and negative surges at the instants of the line voltage steps, and the input voltage on CH-4 trace as a square-wave between 5V and 12V (if the waveforms do not look as described above, turn OFF the “OUT ON” button of the DC POWER SUPPLY and verify the previous steps)
- 5) turn ON the ELECTRONIC “LOAD ON” button. In these conditions you should see the load current on the CH-1 trace of the OSCILLOSCOPE as a flat waveform at 200mA average level with small positive and negative surges at the instants of the line voltage steps, the DC+AC components of the output voltage on the CH-2 trace as a waveform with 24V average value with small positive and negative surges at the instants of the load current steps, the AC component of output voltage on CH-3 trace as a flat waveform at zero level with small positive and negative surges at the instants of the load current steps, and the input voltage on CH-4 trace as a flat line at 5V level (if the waveforms do not look as described above, turn OFF the “OUT ON” button of the DC POWER SUPPLY and verify the previous steps)
- 6) record in Table 1 the magnitude of the output voltage surges after each line transient for the load current values listed in Table 1 (you do not need to turn OFF the ELECTRONIC LOAD “LOAD ON” button while adjusting the load current)
- 7) turn OFF the “LOAD ON” button of the ELECTRONIC LOAD and the “OUT ON” button of the DC POWER SUPPLY, then open the jumper J_2 to disconnect the C_5 (4.7 μ F) output capacitor, repeat the steps 4) to 6), and report the results in Table 1
- 8) turn OFF the “LOAD ON” button of the ELECTRONIC LOAD and the “OUT ON” button of the DC POWER SUPPLY, then short the jumper J_{17} on right side to connect the R_8 , C_9 , C_{11} parts to the error amplifier, repeat the steps 4) to 6), and report the results in Table 1
- 9) at the end of the measurements, turn OFF the “LOAD ON” button of the ELECTRONIC LOAD and the “OUT ON” button of the DC POWER SUPPLY, then switch off all the instruments



Test#2: measure and calculate

For the operating conditions of Table 2, measure the peak output voltage overshoot and undershoot, with a dynamic source connected to the input.

Table 2. Line transient overshoot and undershoot magnitude of TPS55340 boost regulator at $f_s = 400\text{kHz}$ with $L = 10\mu\text{H}$ for different load current values.

$C_{out} = 3 \times 4.7\mu\text{F}; R_7, C_8, C_{10}$ connected			$C_{out} = 2 \times 4.7\mu\text{F}; R_7, C_8, C_{10}$ connected			$C_{out} = 2 \times 4.7\mu\text{F}; R_8, C_9, C_{11}$ connected		
ΔV_{out}	V_{in} 5V→12V	V_{in} 12V→5V	ΔV_{out}	V_{in} 5V→12V	V_{in} 12V→5V	ΔV_{out}	V_{in} 5V→12V	V_{in} 12V→5V
$I_{out}=0.2\text{A}$			$I_{out}=0.2\text{A}$			$I_{out}=0.2\text{A}$		
$I_{out}=0.4\text{A}$			$I_{out}=0.4\text{A}$			$I_{out}=0.4\text{A}$		
$I_{out}=0.6\text{A}$			$I_{out}=0.6\text{A}$			$I_{out}=0.6\text{A}$		

Feedback compensation components:

J_{17} sh left: $R_c=R_7=976\Omega$, $C_c=C_{10}=150\text{nF}$, $C_s=C_8=68\text{nF}$ [$f_c=1.5\text{kHz}$, $\varphi_c=45^\circ$ @O.C.⁽⁵⁾]

J_{17} sh right: $R_c=R_8=2.37\text{k}\Omega$, $C_c=C_{11}=470\text{nF}$, $C_s=C_9=220\text{pF}$ [$f_c=6.5\text{kHz}$, $\varphi_c=45^\circ$ @O.C.⁽⁵⁾]

⁽⁵⁾ Operating Conditions (O.C.): $V_{in}=5\text{V}$, $I_{out}=1.2\text{A}$, $L=10\mu\text{H}$, $C_{out} = 3 \times 4.7\mu\text{F}$.

Inductor

J_1 - J_5 sh: $L=L_1=10\mu\text{H}$

J_5 - J_{10} sh: $L=L_2=3.3\mu\text{H}$

Output capacitor:

J_2 op: $C_{out}=2 \times 4.7\mu\text{F}$

J_2 sh: $C_{out}=3 \times 4.7\mu\text{F}$

Answer:

- Is the line transient voltage overshoot magnitude bigger than the undershoot magnitude? yes no it depends on load current
- Is the line transient response characterized by oscillations? yes no it depends on load current
- How does the line transient surge magnitude change when the load current increases? it increases with current it decreases with current it is not correlated
- What is the factor determining the strongest change in the line transient surge magnitude? the output capacitor the compensation they are equivalent



Discussion

In Test#1 we are interested in investigating correlations among the load transient response of the boost regulator, the line voltage and the setup of output capacitor and feedback compensation.

A voltage regulator with a good load transient response yields a small output voltage surge when the load current suddenly steps up or steps down. Typical specifications for real world dc-dc power supplies require that the load transient surges are limited within about $\pm 5\%$ of the average output nominal voltage. A simple concept can be applied to quickly assess the impact of any physical or operating parameter on the load transient performance of a voltage regulator: the magnitude of load transient surges decreases if the voltage loop cross-over frequency increases. In fact, a higher cross-over frequency improves the reactivity of the control voltage v_c (see *Figures 1 and 2*) to load changes. This results in a faster response of the inductor current to the load demand, thus shortening the duration of the time interval wherein the output capacitor has to sustain the unbalance between the inductor current and the load current (see the *TI-PMLK BUCK Experiment Book* and *TI-PMLK LDO Experiment Book*). The cross-over frequency and the load transient response of a peak-current controller boost regulator are influenced by three main elements: (a) the inherent dynamic properties of the boost topology, (b) the setup of the peak current control loop, and (c) the setup of the voltage feedback compensation. The combination of these elements determines the capability of the boost regulator to reject the effects of a load perturbation on the output voltage. Regarding the point (a), formulae (1) to (5) allow the analysis of the impact of input voltage and output capacitor. In particular, a higher input voltage involves a higher DC gain $G_{v_{c0}}$ and a higher RHP frequency ω_{RHP} . The resulting combined effect is that, for a given EA setup, a higher input voltage results in a higher cross-over frequency, as shown in Figure 5 of the *Theory Background* section, and then a better load transient performance (see the *TI-PMLK BUCK Experiment Book* to assess the difference between the peak current mode controlled buck and boost regulators). The output capacitor setup with $3 \times 4.7\mu\text{F}$ or $2 \times 4.7\mu\text{F}$ identical capacitors does not change the ESR frequency ω_{ESR} given in formula (2), whereas the LFP frequency ω_{LFP} decreases when the output capacitance C_{out} increases. This results in a decrease of the crossover frequency. Nevertheless, the higher capacitance can balance the decrease of the cross-over frequency, as it can sustain for a longer time the unbalance between the inductor current and the load current. Overall, the two setup $3 \times 4.7\mu\text{F}$ or $2 \times 4.7\mu\text{F}$ should not make a significant difference in load transient performance. The impact of the peak current control loop setup on load transient performance can be understood by means of formulae (1) and (4). Whatever element yields and increase of the quality factor Q_s , determines an increase of the control-to-output gain and therefore a better load transient performance. The plot of Figure 3 highlights that Q_s increases with the input voltage, in the range of operation of the TPS55340. An EA designed to achieve a higher crossover frequency determines an improvement of the load transient performance.

[NOTE: Given the voltage loop gain T , the cross-over frequency ω_c is the frequency such that the loop gain magnitude equals 1, that is $|T(\omega_c)|=1$. An explicit formula for ω_c is not available. The cross-over frequency ω_c can be determined by means of MATLAB® [8]. If the loop gain transfer function T is not available, it can be measured by means of a network vector analyzer [9] using the 10Ω injection resistor R_g mounted in the TPS55340 board]

In Test#2 we are interested in investigating correlations among the line transient response of the boost regulator, the load current and the setup of output capacitor and feedback compensation.

A voltage regulator with a good line transient response yields a small output voltage surge when the line voltage suddenly steps up or steps down. Typical specifications for real world dc-dc power supplies require that the line transient surges are limited within about $\pm 5\%$ of the average output nominal voltage. The correlation of line transient response with the output capacitor and voltage feedback compensation is the same discussed above for the load transient. The inherent feedforward action implemented by the peak current control modulator, shown in Figure 2, has a big influence on the line transient response of the peak current controlled boost regulator. In particular, as the slope S_e of the current signal is inversely proportional to the input voltage, the duty-cycle D is promptly adjusted with change in input voltage. The level of the control signal v_c , in fact, is mainly determined by the load current demand. So that, for a given load current, if a line transient occurs, the control signal v_c is kept temporarily fixed by the voltage error-amplifier, while the PWM comparator changes the duty-cycle D instantaneously. Eventually, the control signal v_c value is finely adjusted by the voltage error amplifier. The line transient performance of a peak current controlled boost regulator is then mainly determined by the feedforward action discussed above. Best performances are achieved when the ratio S_e/S_n of formula (4) is small. But, a very small ratio S_e/S_n may lead to instability if Q_s (which depends on the input voltage) becomes negative.



Experimental plots

The plots collected in the Figures 9 to 12 show some examples of load and line transient response of the TPS55340 boost regulator.

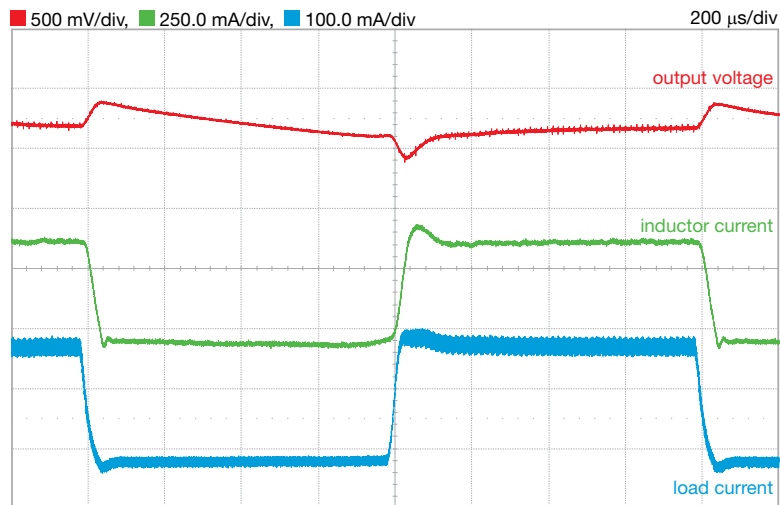

Figure 9. TPS55340 boost regulator load transient response with R_7 , C_8 , C_{10} connected (lower cross-over frequency): $V_{in}=12V$, $I_{out}=0.2A$ to $0.4A$, $f_s=400kHz$, $L=10\mu H$

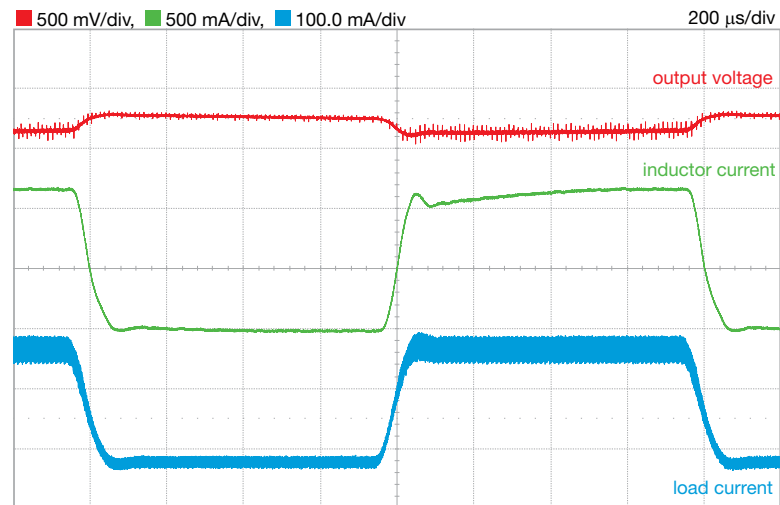

Figure 10. TPS55340 boost regulator load transient response R_8 , C_9 , C_{11} connected (higher cross-over frequency): $V_{in}=5V$, $I_{out}=0.2A$ to $0.4A$, $f_s=400kHz$, $L=10\mu H$

The plots of Figures 9 and 10 highlight the influence of the voltage feedback error amplifier setup and of the input voltage on the load transient response of the TPS55340 boost regulator. In Figure 9 we see the response with 12V input voltage and lower cross-over error amplifier setup. In Figure 10 we see that, although the input voltage is lower, the higher cross-over error amplifier setup improves the load transient response by reducing the overshoot and undershoot surge magnitude.



Experimental plots

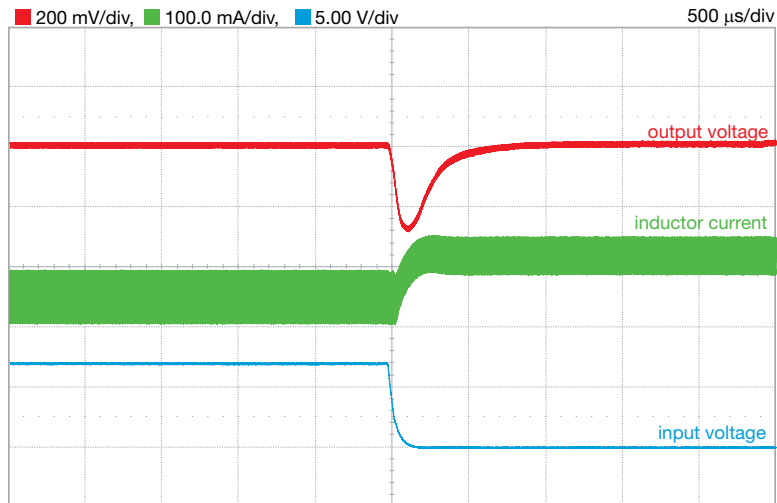

Figure 11. TPS55340 boost regulator line transient response with R_7 , C_8 , C_{10} connected (lower cross-over frequency): $V_{in}=12V$ to $5V$, $I_{out}=0.5A$, $f_s=400kHz$, $L=3.3\mu H$

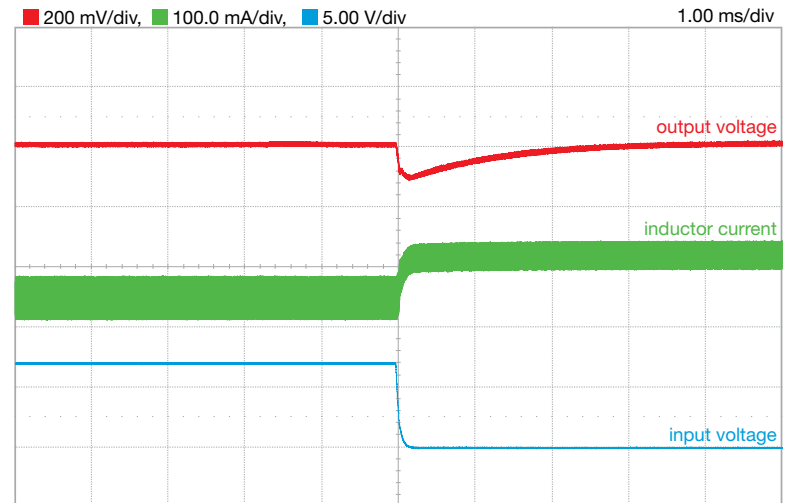

Figure 12. TPS55340 boost regulator line transient response with R_8 , C_9 , C_{11} connected (higher cross-over frequency): $V_{in}=12V$ to $5V$, $I_{out}=0.5A$, $f_s=400kHz$, $L=3.3\mu H$

The plots of Figures 11 and 12 highlight the influence of the voltage feedback error amplifier setup on the line transient response of the TPS55340 boost regulator. In Figure 11 we see the response with lower cross-over error amplifier setup, whereas in Figure 12 we see that the higher cross-over error amplifier setup improves the load transient response by reducing the undershoot surge magnitude.

Experiment 4

The goal of this experiment is to analyze the influence of the input voltage and of the inductor on the maximum average load current that the boost regulator can deliver under current limit conditions. The TPS55340 and the LM5122 boost regulators are used for this experiment.



TPS55340 Case Study

The goal of this test is to analyze the influence of input voltage, inductor, switching frequency and efficiency on the maximum load current that the boost regulator can deliver under current limit conditions. The test is realized by means of the TPS55340 boost regulator.

The TI-PMLK TPS55340 boost regulator provides an output voltage $V_{out}=24V$, with an input voltage V_{in} from 5V to 12V⁽¹⁾, and a load current I_{out} up to 0.6A. Figure 1 shows the basic circuit schematic, where the devices highlighted are: the input capacitor (C_i), the inductor (L), the output capacitor (C_o), the Schottky diode (D_1), the feedback compensation (R_c, C_c, C_s) and the output voltage sensing (R_{SH}, R_{SL}). A cycle-by-cycle current-limiting circuit is implemented into the TPS55340 controller, which shuts down the internal MOSFET if its instantaneous current exceeds 6.6A (at 25°C) when it is in the ON state. The current limiting circuit determines the maximum average current I_{Lmax} of the input inductor, whose value depends on input voltage V_{in} , switching frequency f_s and inductance L . The converter efficiency also influences the current limit as it impacts the average inductor current. Therefore, the maximum output current I_{outmax} the boost regulator can deliver is determined by the operating conditions. The current limiting action inhibits the regulation of output voltage, determining its drop below the desired nominal value.

⁽¹⁾ Restricted range adopted for this educational board, compared to the 2.9V to 32V full range of TPS55340 [5]

[NOTE: The TPS55340 has an internal current sensing, which does not require the use of an additional external current sensing resistor. In the following *LM5122 Case Study*, we will analyze current limit issues when an external current sensing resistor is used]

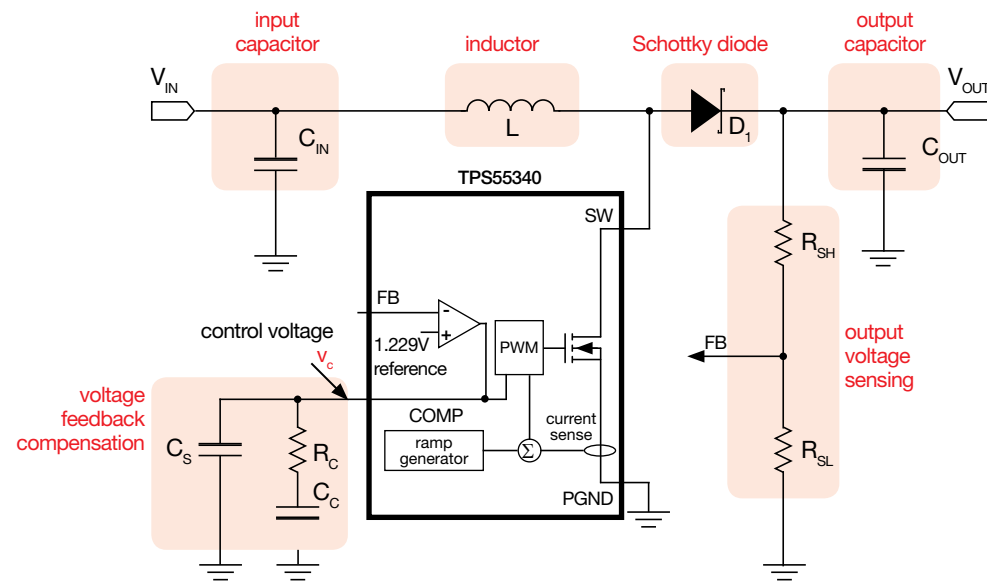

Figure 1. Simplified schematic of the TPS55340 Boost regulator

Test#1. We detect the maximum output current that the TPS55340 can deliver to the load, determined by the internal current limit circuit, by slowly increasing the load current while watching the output voltage. When the current load exceeds the current limit threshold, the output voltage regulation is lost. We record the input and output voltages and currents, we calculate the efficiency and we repeat the test for different values of input voltage, inductor, switching frequency and efficiency. The change of efficiency is emulated, for given input voltage, inductor and switching frequency, by means of a resistor mounted in the TPS55340 boost regulator, connected in series to the inductor, which can be bypassed by means of a jumper.



TPS55340 current limit: Theory Background

The correlations among current limiting action, operating conditions and converter efficiency are summarized in the following formulae. (see [1][2][3] for more details on boost topology operation and modeling and MOSFETs losses calculation; see [5] for more details on TPS55340 operation and features; refer to Figure 1 to determine inductor and MOSFETs voltages and currents)

Cycle-by-cycle current limiting

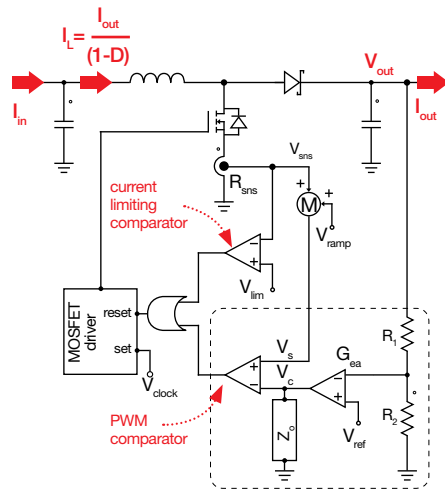

Figure 2

Figure 2 shows in detail the PWM and current limit circuits. The V_{clock} signal triggers the MOSFET turn ON at the begin of the switching period. The MOSFET is turned OFF either when the instant sensing signal $V_s = R_{\text{sns}} i + V_{\text{ramp}}$ exceeds the feedback control signal V_c , at the input of the PWM comparator, or when the sensing signal $V_{\text{sns}} = R_{\text{sns}} i$ exceeds the internal threshold V_{lim} , at the input of the current limit comparator. Figure 3(a) shows the normal operation. In this case we have:

$$(1) I_L + \Delta i_{Lpp} / 2 = I_{\text{out}} / D + V_{\text{out}} DD' / (2f_s L) < V_{\text{lim}} / R_{\text{sns}} = I_{\text{lim}}$$

where $D' = 1 - D$. Figure 3(b) shows the current limit operation. In this case we have:

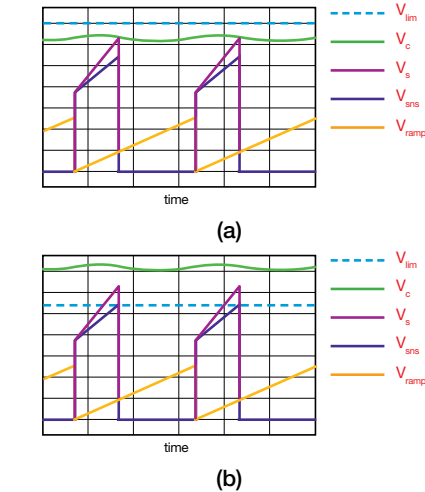

Figure 3

$$(2) I_{\text{outmax}} / D' + V_{\text{out}} DD' / (2f_s L) = I_{\text{lim}}$$

From (2) it follows that, given the current limit value I_{lim} , the maximum current I_{outmax} the boost regulator can deliver to the load is determined by the input voltage V_{in} , the inductance L and the switching frequency f_s , and is given by (3):

$$(3) I_{\text{outmax}} = D' [I_{\text{lim}} - V_{\text{out}} DD' / (2f_s L)]$$

Putting $D = 1 - V_{\text{in}} / V_{\text{out}}$ in (3) yields (4):

$$(4) I_{\text{outmax}} = V_{\text{in}} / V_{\text{out}} [I_{\text{lim}} - V_{\text{in}} (1 - V_{\text{in}} / V_{\text{out}}) / (2f_s L)]$$

The efficiency η of the converter influences the I_{outmax} current, as shown in (5):

$$(5) I_{\text{outmax}} = \eta V_{\text{in}} / V_{\text{out}} [I_{\text{lim}} - V_{\text{in}} (1 - V_{\text{in}} / V_{\text{out}}) / (2f_s L)]$$

Boost converter losses⁽¹⁾

MOSFET

conduction: $P_{\text{MOS,c}} = R_{\text{ds}} I_{\text{out}}^2 \alpha_{\text{pp}} D / D'^2$

switching: $P_{\text{MOS,sw}} \cong V_{\text{out}} I_{\text{out}} f_s t_{\text{sw}} / D'$

MOSFET

current sensing $P_{\text{sns}} = R_{\text{sns}} I_{\text{out}}^2 \alpha_{\text{pp}} D / D'^2$

Schottky diode

conduction: $P_{\text{rect}} = V_F I_{\text{out}}$

Inductor

winding: $P_{L,w} = ESR_L I_{\text{out}}^2 \alpha_{\text{pp}} / D'^2$

core⁽²⁾:

$$P_{Lc} = K_1 f_s^x (K_2 \Delta i_{\text{pp}})^y$$

Capacitors

input: $P_{\text{Cin}} = \frac{1}{12} ESR_{\text{Cin}} \Delta i_{\text{pp}}^2$

output: $P_{\text{Cout}} = ESR_{\text{Cout}} I_{\text{out}}^2 D / D'$

IC

bias: $P_{\text{IC}} = V_{\text{in}} I_{\mu}$

⁽¹⁾ see [1][2][3]

⁽²⁾ f_s [kHz], Δi_{pp} [A], P_{Lc} [mW]

Good to know

1 $D = 1 - \eta \frac{V_{\text{in}}}{V_{\text{out}}}$; $\eta = \frac{P_{\text{out}}}{P_{\text{out}} + P_{\text{loss}}}$

2 $D' = 1 - D$

3 $\alpha_{\text{pp}} = 1 + D'^2 \Delta i_{\text{pp}}^2 / (12 I_{\text{out}}^2)$

4 $\Delta i_{\text{pp}} = V_{\text{in}} D / (f_s L)$

5 R_{ds} , t_{sw} and Q_g are influenced by the gate driver voltage V_{dr} , the junction temperature T_j and the operating conditions;

6 K_1 , K_2 , x , y coefficients of P_{Lc} loss formula, depend on inductor core material and size;

7 In case of capacitors in parallel the equivalent ESR has to be calculated;

8 Additional losses depend on PCB traces resistance and ancillary parts;

9 The total converter power losses are:

$$P_{\text{loss}} = P_{\text{MOS,c}} + P_{\text{MOS,sw}} + P_{\text{sns}} + P_{\text{rect}} + P_{L,w} + P_{Lc} + P_{\text{Cin}} + P_{\text{Cout}} + P_{\text{IC}}$$



TPS55340 Experiment set-up: configuration

The instruments needed for this test are: a DC POWER SUPPLY, four MULTIMETERS and a DC ELECTRONIC LOAD. Figure 4 shows the instruments connections. Follow the instructions provided in next page to set-up the **connections**.

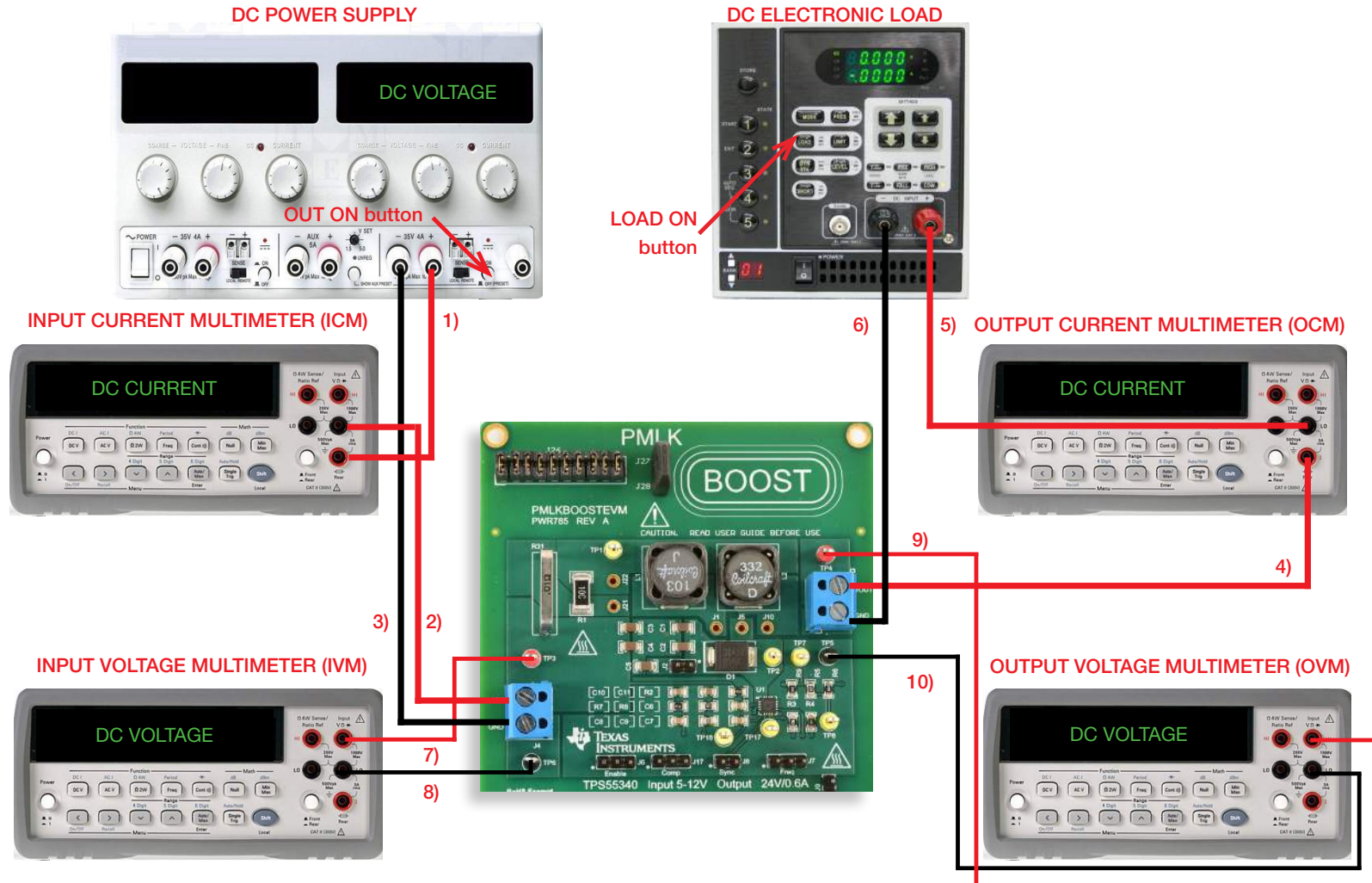

Figure 4. Experiment set-up.



TPS55340 Experiment set-up: instructions

With all the instruments turned off, make the following **connections**:

- 1) connect the POSITIVE (RED) OUTPUT of the DC POWER SUPPLY to the POSITIVE (RED) CURRENT INPUT of the INPUT CURRENT MULTIMETER (ICM)
- 2) connect the NEGATIVE (BLACK) CURRENT INPUT of the INPUT CURRENT MULTIMETER (ICM) to the INPUT (VIN) of the J_4 screw terminal of the TPS55340 boost regulator
- 3) connect the NEGATIVE (BLACK) OUTPUT of the DC POWER SUPPLY to the GROUND (GND) of the J_4 screw terminal of the TPS55340 boost regulator
- 4) connect the OUTPUT (VOUT) of the J_3 screw terminal of the TPS55340 boost regulator to the POSITIVE (RED) CURRENT INPUT of the OUTPUT CURRENT MULTIMETER (OCM)
- 5) connect the NEGATIVE (BLACK) CURRENT INPUT of the OUTPUT CURRENT MULTIMETER (OCM) to the POSITIVE (RED) INPUT of the ELECTRONIC LOAD
- 6) connect the NEGATIVE (BLACK) INPUT of the ELECTRONIC LOAD to the GROUND (GND) of the J_3 screw terminal of the TPS55340 boost regulator
- 7) connect the POSITIVE (RED) VOLTAGE INPUT of the INPUT VOLTAGE MULTIMETER (IVM) to the TEST PIN TP_3 which is the VIN of the TPS55340 boost regulator
- 8) connect the NEGATIVE (BLACK) VOLTAGE INPUT of the INPUT VOLTAGE MULTIMETER (IVM) to the TEST PIN TP_6 which is GND of the TPS55340 boost regulator
- 9) connect the POSITIVE (RED) VOLTAGE INPUT of the OUTPUT VOLTAGE MULTIMETER (OVM) to the TEST PIN TP_4 which is VOUT of the TPS55340 boost regulator
- 10) connect the NEGATIVE (BLACK) VOLTAGE INPUT of the OUTPUT VOLTAGE MULTIMETER (OVM) to the TEST PIN TP_5 which is GND of the TPS55340 boost regulator



Test#1 (TPS55340): preparation and procedure

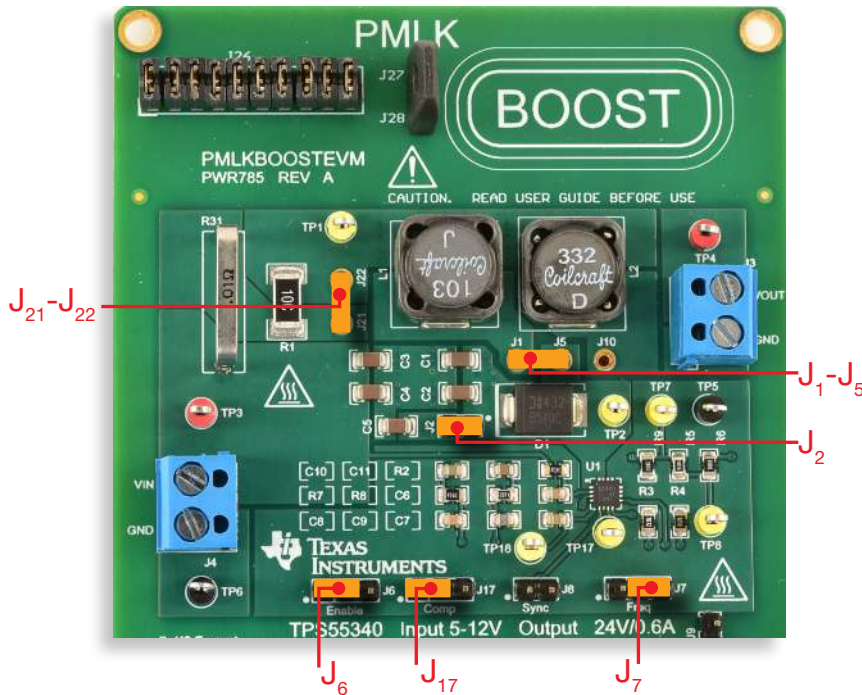

Figure 5. TPS55340 boost board: jumpers set-up for Test#1

Initial jumpers set-up (see Figure 5):

- J_6 shorted left → boost operation enabled
- J_2 shorted → C_5 (4.7 μ F) output capacitor connected
- J_7 shorted right → switching frequency $f_s = 400\text{kHz}$
- J_{17} shorted left → error amplifier gain setup with parts R_7 , C_8 , C_{10} connected (lower cross-over frequency)
- $J_1 - J_5$ shorted → L_1 (10 μ H) inductor connected
- $J_{21} - J_{22}$ shorted → loss emulation resistor R_1 bypassed
- J_8 open → boost operation with internal synchronization

Test Procedure:

- 1) turn on the MULTIMETERS, set the ICM and the OCM in DC CURRENT MODE, set the IVM and the OVM in DC VOLTAGE MODE
- 2) turn on the POWER SUPPLY (ensure that the OUT ON button is OFF), set the voltage at the initial value of 6V, and set the CURRENT LIMIT > 3A
- 3) turn on the ELECTRONIC LOAD (ensure that the LOAD ON button is OFF), set the CONSTANT CURRENT MODE and set the current at 0.2A
- 4) turn ON the POWER SUPPLY "OUT ON" button and adjust the DC POWER SUPPLY knob until you read 6V in the IVM display. In these conditions you should read about 24V in the OVM display, 0A in the OCM display and a very small positive value in the ICM display (if you do read values different than as described above, turn OFF the "OUT ON" button of the DC POWER SUPPLY and verify the previous steps)
- 5) turn ON the ELECTRONIC LOAD ON button and adjust the DC POWER SUPPLY knob until you read 6V in the IVM display. In these conditions you should read about 24V in the OVM display, 0.2A in the OCM display, about 0.8A in the ICM display (if the values are much different than the ones listed above, turn OFF the "LOAD ON" button of the ELECTRONIC LOAD and the "OUT ON" button of the DC POWER SUPPLY and verify the experiment setup)
- 6) while slowly increasing the load current of the ELECTRONIC LOAD, watch the output voltage value on the OVM display and record the highest value of the load current I_{outmax} for which you get the output voltage regulated at 24V. When you loose the output voltage regulation, turn OFF the "LOAD ON" button of the ELECTRONIC LOAD, set its current to a value slightly smaller than I_{outmax} , turn ON the "LOAD ON" button of the ELECTRONIC LOAD, and read the input voltage value on the IVM display, the output voltage value on the OVM display, the input current value on the ICM display, the output current value on the OCM display. Repeat this step 6) for all the setup conditions listed in Table 1, by shorting the jumpers $J_5 - J_{10}$ to connect the L_2 (3.3 μ H) inductor, shorting the jumper J_7 to setup the switching frequency $f_s = 600\text{kHz}$, and opening the jumpers $J_{21} - J_{22}$ to connect the emulation resistor R_1 in series to the inductor [**WARNING:** you must turn OFF the ELECTRONIC LOAD "LOAD ON" button and the POWER SUPPLY "OUT ON" button while changing the inductor or switching frequency setup]
- 7) at the end of the measurements, turn OFF the "LOAD ON" button of the ELECTRONIC LOAD and the "OUT ON" button of the DC POWER SUPPLY, then switch off all the instruments.



Test#1 (TPS55340): measure and calculate

For the operating conditions of Table 1:

- 1) measure the **maximum current** I_{outmax} the TPS55340 boost regulator is able to deliver to the load while regulating the output voltage V_{out} at **24V** (detect when output voltage is more than 1% lower than the nominal voltage), and report the value in Table 1
- 2) measure the average input voltage V_{in} , input current I_{in} , output voltage V_{out} and output current I_{out} , corresponding to a load current slightly lower than I_{outmax} , and calculate the efficiency of the converter $\eta = (V_{out} I_{out}) / (V_{in} I_{in})$, and report the result in Table 1.

Table 1. Maximum current delivered by the TPS55340 boost regulator for different input voltage values, inductance, switching frequency and efficiency.

I_{outlim} [A]	η [%]	$L = L_1 = 10\mu\text{H}$		$L = L_2 = 3.3\mu\text{H}$	
		$J_{21}-J_{22}$ open	$J_{21}-J_{22}$ shorted	$J_{21}-J_{22}$ open	$J_{21}-J_{22}$ shorted
$f_s=400\text{kHz}$	$V_{in}=6\text{V}$				
	$V_{in}=12\text{V}$				
$f_s=600\text{kHz}$	$V_{in}=6\text{V}$				
	$V_{in}=12\text{V}$				

Inductors:

J_1-J_5 sh: $L=L_1=10\mu\text{H}$, $ESR_{L1}=62.7\text{m}\Omega$;

J_5-J_{10} sh: $L=L_2=3.3\mu\text{H}$, $ESR_{L2}=17.3\text{m}\Omega$;

J_1-J_5 sh or J_5-J_{10} sh: $K_1=0.261$, $K_2=0.92$, $x=1.21$, $y=2.01$

TPS55340 integrated MOSFET:

$R_{ds}=110\text{m}\Omega$,

$I_{\mu}=500\mu\text{A}$,

$\alpha_{sw}=1.5\text{ns/V}$,

$VF=325\text{mV}$

$R_{sns}=15\text{m}\Omega$,

$t_{sw}=\alpha_{sw} V_{out}$

Capacitors:

J_2 sh $ESRC_{out}=1\text{m}\Omega$.

$ESRC_{in}=1.5\text{m}\Omega$

Answer:

- 1) Is the load current limit higher with inductor L_1 or with inductor L_2 ?

<input type="checkbox"/> higher with L_1	<input type="checkbox"/> higher with L_2	<input type="checkbox"/> it depends on line voltage	<input type="checkbox"/> no influence
--	--	---	---------------------------------------
- 2) Does a higher converter efficiency increase or decrease the load current limit?

<input type="checkbox"/> increases	<input type="checkbox"/> decreases	<input type="checkbox"/> it depends on line voltage	<input type="checkbox"/> it depends on inductor
------------------------------------	------------------------------------	---	---
- 3) Does a higher input voltage increase or decrease the load current limit?

<input type="checkbox"/> increases	<input type="checkbox"/> decreases	<input type="checkbox"/> no influence	<input type="checkbox"/> it depends on inductor
------------------------------------	------------------------------------	---------------------------------------	---



LM5122 Case Study

The goal of this test is to analyze the influence of parasitic inductances on the maximum load current that the boost regulator can deliver under current limit. The test is realized by means of the LM5122 boost regulator.

The TI-PMLK LM5122 boost regulator operates with $V_{in}=[9,20]V^{(1)}$, while regulating the output voltage at the nominal value $V_{out}=24V$, $I_{out}=[0,2]A$. Figure 6 shows the simplified circuit schematic of the regulator. The LM5122 features a peak cycle-by-cycle current limit function. If the current sensing voltage between the pins CSP and CSN exceeds the 75mV cycle-by-cycle current limit threshold, the current limit comparator immediately terminates the LO output. As highlighted in the *TPS55340 Case Study*, the current limiting circuit determines the maximum average current I_{Lmax} of the input inductor, whose value depends on the input voltage V_{in} , on the switching frequency f_s and on the inductance L . Unlike the TPS55340, the LM5122 uses the external resistor R_s to sense the inductor current. The surface-mount current sensing resistors normally used for peak-current controllers are characterized by a very small parasitic inductance. The TI-PMLK LM5122 boost regulator mounts a through-hole U-shape shunt resistor, which is used to hang a current probe for oscilloscope acquisition of the inductor current waveform, and which is also used as current sensing resistor for the peak current control. The parasitic inductance of such sensing resistor is in the range of tens of nH and it influences the current limit.

⁽¹⁾ Restricted range adopted for this educational board, compared to the 4.5V to 65V full range of LM5122 [4]

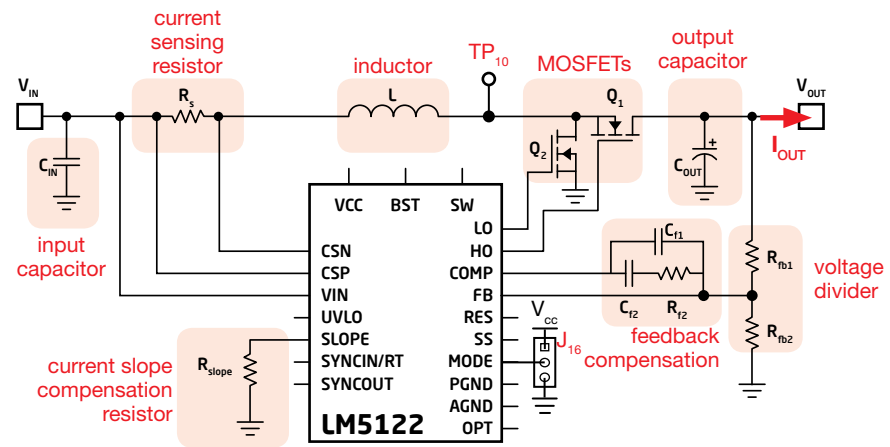

Figure 6. Simplified schematic of the LM5122 BOOST regulator

Test#1. We detect the maximum output current that the LM5122 can deliver to the load, set by the internal current limit circuit, by slowly increasing the load current while watching the output voltage. When the current threshold is reached, the output voltage regulation is lost. We observe the effect of the parasitic inductance of the sensing resistor on the maximum output current, while operating the boost converter with the two power inductors of values 3.3 μ H and 10 μ H mounted on the board. We will also see that the maximum current that the LM5122 boost regulator can deliver can be increased, when the 3.3 μ H inductor is used, by modifying the sensing resistor.



LM5122 current limit: Theory Background

The correlations among current limiting action, operating conditions and converter efficiency are summarized in the following formulae (see [1][2][3] for more details on boost topology operation and modeling and MOSFETs losses calculation; see [4] for more details on LM5122 operation and features)

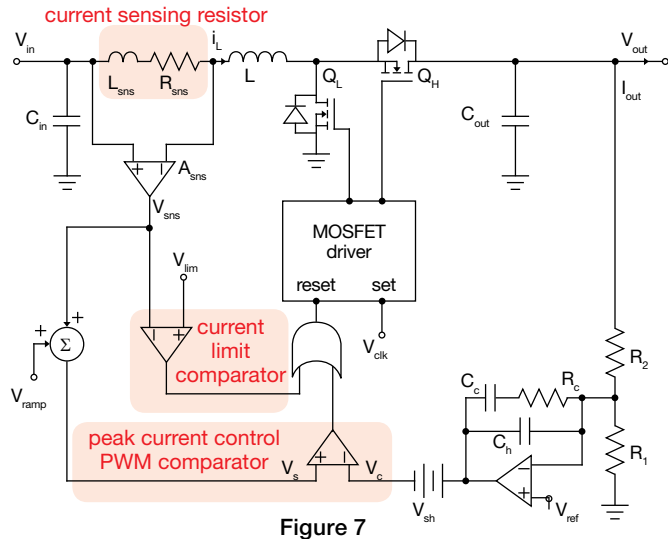

Figure 7

Figure 7 shows the schematic of the LM5122 boost regulator with peak-current-control and current limit circuitry. The current sensing resistor is highlighted. It is characterized by a resistance R_{sns} and a parasitic inductance L_{sns} . To assess the impact of L_{sns} on the overall operation of the peak-current controlled boost converter, let us first analyze the operation with $L_{sns}=0$. Like in TPS55340 boost regulator, the V_{clk} signal triggers the MOSFET Q_L turn ON at the begin of the switching period. The MOSFET Q_L is turned OFF either when the instant sensing signal $V_s = R_{sns} i_L + V_{ramp}$ exceeds the feedback control signal V_c , at the input of the PWM comparator, or when the sensing signal $V_{sns} = R_{sns} i_L$ exceeds the internal threshold V_{lim} , at the input of the current limit comparator. Therefore, if the load current does not exceed the limit $I_{outmax} = \eta V_{in} [(I_{lim} - V_{in} (1 - V_{in}/V_{out})) / (2f_s L)] / V_{out}$ ⁽¹⁾, the waveforms of V_s , V_c , V_{lim} and V_{ramp} will look as in Figure 8(a). The inductance L_{sns} influences the maximum inductor current that the boost converter can sustain before the current limit shuts down the MOSFET Q_L . L_{sns} is in series with the inductance L , which is much bigger than L_{sns} . Thus, the slope of the inductor current is determined by its own inductance L .

⁽¹⁾ see *Theory Background* section of Test#1; η is the converter efficiency.

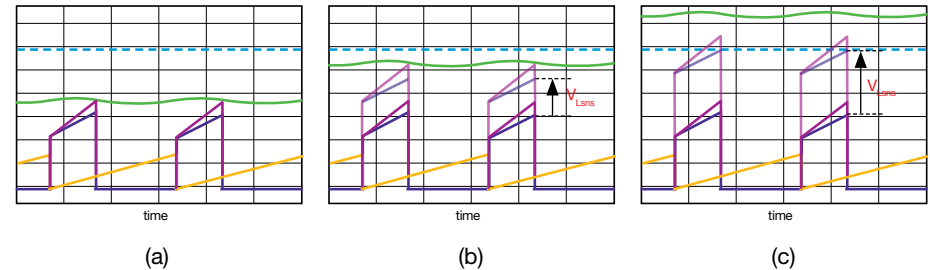

Figure 8. --- V_{lim} , --- V_c , --- $V_s @ L_{sns}=0$, --- $V_{sns} @ L_{sns}=0$, --- V_{ramp} , --- $V_s @ L_{sns} \neq 0$, --- $V_{sns} @ L_{sns} \neq 0$

The slope is $V_{in}/L > 0$ since the MOSFET Q_L turns ON, at the begin of the switching period, until the MOSFET Q_L turns OFF, at the instant where $V_s = V_c$, then the slope is $(V_{in} - V_{out})/L < 0$ until the begin of the next switching period. As a consequence, the voltage across the parasitic inductance L_{sns} is $V_{Lsns} = V_{in} L_{sns}/L > 0$ during the ON time of the MOSFET Q_L . In this interval of time, the signal V_s is used by the **peak current control PWM comparator** and the signal V_{sns} is used by the **current limit comparator** to determine the boost converter duty-cycle. Figures 8(b) and 8(c) highlight that the effect of the V_{Lsns} voltage across the parasitic inductance is a rise in the V_{sns} and V_s signals. If L_{sns} is not too big, the V_{sns} signal does not exceed the V_{lim} limit, as shown in Figure 8(b). Then, the V_s signal reaches the control signal level V_c before the V_{sns} reaches the V_{lim} limit. Then, the action of the peak-current-control PWM modulator is prevalent, and it is able to set the required duty-cycle to regulate the output voltage. If L_{sns} is too big, the V_{sns} reaches the V_{lim} limit before the V_s signal reaches the control signal level V_c , as shown in Figure 8(c). Then, the action of the current limit comparator is prevalent, and the peak-current-control PWM modulator it not able to set the required duty-cycle to regulate the output voltage. The maximum inductor current is thus reduced by the parasitic inductance and it is given by (6):

$$(6) \quad I_{outmax} = \eta V_{in} [(I_{lim} - V_{in} (1 - V_{in}/V_{out})) / (2f_s L) - V_{in} L_{sns}/L] / V_{out}$$

The formula (6) highlights that a smaller inductance L increases the effect of the parasitic inductance L_{sns} on the maximum current that can be delivered by the boost converter.



LM5122 Experiment set-up: configuration

The instruments needed for this test are: a DC POWER SUPPLY, four MULTIMETERS, an OSCILLOSCOPE and a DC ELECTRONIC LOAD. Figure 9 shows the instruments connections. Follow the instructions provided in next page to set-up the **connections**.

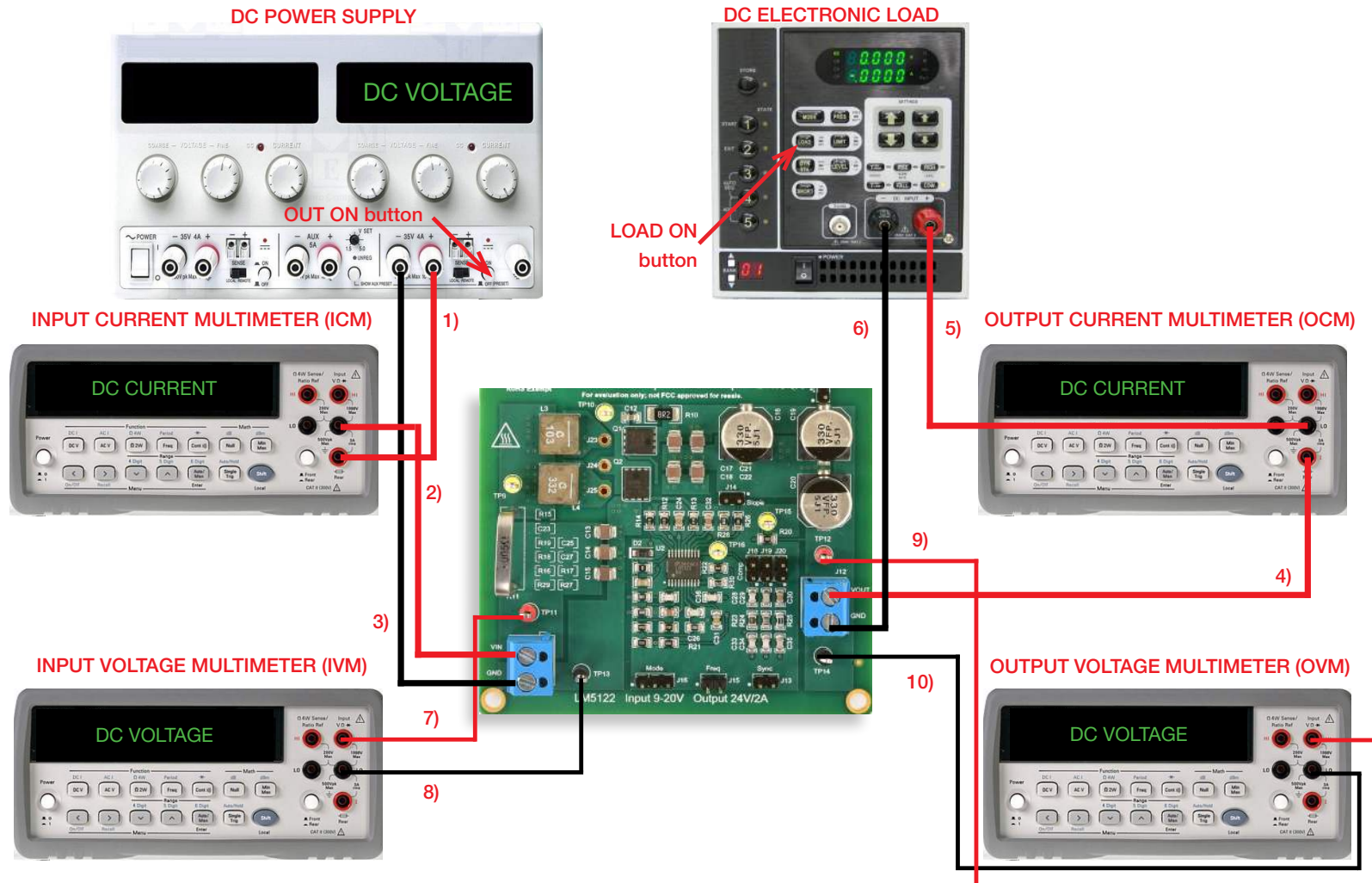

Figure 9. Experiment set-up.



LM5122 Experiment set-up: instructions

With all the instruments turned off, make the following **connections**:

- 1) connect the POSITIVE (RED) OUTPUT of the DC POWER SUPPLY to the POSITIVE (RED) CURRENT INPUT of the INPUT CURRENT MULTIMETER (ICM)
- 2) connect the NEGATIVE (BLACK) CURRENT INPUT of the INPUT CURRENT MULTIMETER (ICM) to the INPUT (VIN) of the J_{11} screw terminal of the LM5122 boost regulator
- 3) connect the NEGATIVE (BLACK) OUTPUT of the DC POWER SUPPLY to the GROUND (GND) of the J_{11} screw terminal of the LM5122 boost regulator
- 4) connect the OUTPUT (VOUT) of the J_{12} screw terminal of the LM5122 boost regulator to the POSITIVE (RED) CURRENT INPUT of the OUTPUT CURRENT MULTIMETER (OCM)
- 5) connect the NEGATIVE (BLACK) CURRENT INPUT of the OUTPUT CURRENT MULTIMETER (OCM) to the POSITIVE (RED) INPUT of the ELECTRONIC LOAD.
- 6) connect the NEGATIVE (BLACK) INPUT of the ELECTRONIC LOAD to the GROUND (GND) of the J_{12} screw terminal of the LM5122 boost regulator
- 7) connect the POSITIVE (RED) VOLTAGE INPUT of the INPUT VOLTAGE MULTIMETER (IVM) to the TEST PIN TP_{11} which is the VIN of the LM5122 boost regulator
- 8) connect the NEGATIVE (BLACK) VOLTAGE INPUT of the INPUT VOLTAGE MULTIMETER (IVM) to the TEST PIN TP_{13} which is GND of the LM5122 boost regulator
- 9) connect the POSITIVE (RED) VOLTAGE INPUT of the OUTPUT VOLTAGE MULTIMETER (OVM) to the TEST PIN TP_{12} which is VOUT of the LM5122 boost regulator
- 10) connect the NEGATIVE (BLACK) VOLTAGE INPUT of the OUTPUT VOLTAGE MULTIMETER (OVM) to the TEST PIN TP_{14} which is GND of the LM5122 boost regulator



Test#2 (LM5122): preparation and procedure

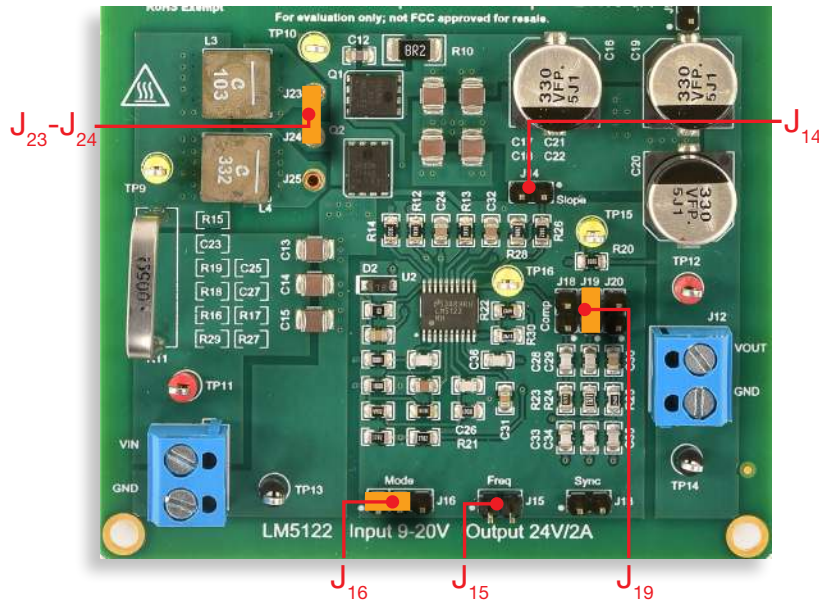

Figure 10. LM5122 board: jumpers set-up for Test#2

Initial jumpers set-up (see Figure 10):

- J_{13} open → no external synchronization signal connected
- J_{14} open → low slope current mode compensation
- J_{15} open → switching frequency $f_s = 250\text{kHz}$
- J_{16} shorted left → SOM setup
- J_{18} open, J_{19} shorted, J_{20} open → error amplifier gain setup with parts R_{24} , C_{29} , C_{34} connected (high cross-over frequency with $L = L_3 = 10\mu\text{H}$, and high slope compensation ramp)
- $J_{23} - J_{24}$ shorted → L_3 ($10\mu\text{H}$) inductor connected

Test Procedure:

- 1) turn on the MULTIMETERS, set the ICM and the OCM in DC CURRENT MODE, set the IVM and the OVM in DC VOLTAGE MODE
- 2) turn on the POWER SUPPLY (ensure that the OUT ON button is OFF), set the voltage at the initial value of 10V and set the CURRENT LIMIT $> 3\text{A}$
- 3) turn on the ELECTRONIC LOAD (ensure that the LOAD ON button is OFF), set the CONSTANT CURRENT MODE and set the current at 0.2A
- 4) turn ON the POWER SUPPLY "OUT ON" button and adjust the DC POWER SUPPLY knob until you read 6V in the IVM display. In these conditions you should read about 24V in the OVM display, 0A in the OCM display and a very small positive value in the ICM display (if you do read values different than as described above, turn OFF the "OUT ON" button of the DC POWER SUPPLY and verify the previous steps)
- 5) turn ON the ELECTRONIC LOAD ON button and adjust the DC POWER SUPPLY knob until you read 6V in the IVM display. In these conditions you should read about 24V in the OVM display, 0.2A in the OCM display, about 0.8A in the ICM display (if the values are much different than the ones listed above, turn OFF the "LOAD ON" button of the ELECTRONIC LOAD and the "OUT ON" button of the DC POWER SUPPLY and verify the experiment setup)
- 6) while slowly increasing the load current of the ELECTRONIC LOAD, watch the output voltage value on the OVM display and record the highest value of the load current I_{outmax} for which you get the output voltage regulated at 24V. When you loose the output voltage regulation, turn OFF the "LOAD ON" button of the ELECTRONIC LOAD, set its current to a value slightly smaller than I_{outmax} , turn ON the "LOAD ON" button of the ELECTRONIC LOAD, and read the input voltage value on the IVM display, the output voltage value on the OVM display, the input current value on the ICM display, the output current value on the OCM display. Repeat this step 6) for all the setup conditions listed in Table 2, by shorting the jumpers $J_{24} - J_{25}$ to connect the L_4 ($3.3\mu\text{H}$) inductor, shorting the jumper J_{15} to setup the switching frequency $f_s = 500\text{kHz}$ and opening the jumper J_{16} to setup DEM operation [WARNING: you must turn OFF the ELECTRONIC LOAD "LOAD ON" button and the POWER SUPPLY "OUT ON" button while changing the inductor or switching frequency setup]
- 7) at the end of the measurements, turn OFF the "LOAD ON" button of the ELECTRONIC LOAD and the "OUT ON" button of the DC POWER SUPPLY, then switch off all the instruments.



Test#2 (LM5122): measure and calculate

For the operating conditions of Table 2:

- 1) measure the maximum current I_{outmax} the LM5122 boost regulator is able to deliver to the load while regulating the output voltage V_{out} at 24V regulation of the (detect when output voltage is more than 1% lower than the nominal voltage), and report the value in Table 2
- 2) measure the average input voltage V_{in} , input current I_{in} , output voltage V_{out} and output current I_{out} , corresponding to a load current slightly lower than I_{outmax} , and calculate the efficiency of the converter $\eta = (V_{out} I_{out}) / (V_{in} I_{in})$, and report the result in Table 2

Table 2. Maximum current delivered by the LM5122 boost regulator for different input voltage values, inductance, switching frequency and mode of operation

I_{outlim} [A]	η [%]	$L = L_3 = 10\mu\text{H}$				$L = L_4 = 3.3\mu\text{H}$			
		SOM setup		DEM setup		SOM setup		DEM setup	
$f_s = 250\text{kHz}$	$V_{in} = 10\text{V}$								
	$V_{in} = 20\text{V}$								
$f_s = 500\text{kHz}$	$V_{in} = 10\text{V}$								
	$V_{in} = 20\text{V}$								

Inductor:

$J_{23}-J_{24}$ shorted → inductor L_3 (powdered core, 10 μH , 2.6A, 0.057 Ω) connected
 $J_{24}-J_{25}$ shorted → inductor L_4 (powdered core, 3.3 μH , 10A, 0.0195 Ω) connected

Switching frequency:

J_{15} open → $f_s = 250\text{kHz}$
 J_{15} shorted → $f_s = 500\text{kHz}$

Operation mode:

J_{16} open → Diode Emulation Mode (DEM)
 J_{16} shorted left → Synchronous Operation Mode (SOM)

Answer:

- 1) Is the load current limit higher with inductor L_3 or with inductor L_4 ?

<input type="checkbox"/> higher with L_3	<input type="checkbox"/> higher with L_4	<input type="checkbox"/> it depends on line voltage	<input type="checkbox"/> no influence
--	--	---	---------------------------------------
- 2) Is the load current limit higher with DEM setup or with SOM setup?

<input type="checkbox"/> DEM	<input type="checkbox"/> SOM	<input type="checkbox"/> it depends on line voltage	<input type="checkbox"/> it depends on inductor
------------------------------	------------------------------	---	---
- 3) Does a higher input voltage increase or decrease the load current limit?

<input type="checkbox"/> increases	<input type="checkbox"/> decreases	<input type="checkbox"/> no influence	<input type="checkbox"/> it depends on inductor
------------------------------------	------------------------------------	---------------------------------------	---



Discussion

In Test#1 we are interested in investigating how the input voltage, the switching frequency, the inductance and the efficiency influence the current limit of the TPS55340 boost regulator. The current limit threshold of a boost regulator is determined by the inductor peak current value. Operating conditions involving a higher inductor peak current value result in a lower current limit threshold. The inductor peak current value is the sum of the average inductor current and half the peak-to-peak ripple. A higher input voltage V_{in} involves a lower average inductor current. Therefore, the operation at a higher input voltage contributes to increase the current limit threshold. If $V_{in} < V_{out}/2$, the ripple current increases as V_{in} increases. In this case, the current limit threshold may increase or decrease, as the input voltage increases, depending on the balance between its opposed effects on average and ripple current. If $V_{in} > V_{out}/2$ the ripple decreases as V_{in} increases. In this case, the current limit threshold increases as the input voltage increases. For the range of input voltage specified in Test#1, we are satisfying the condition $V_{in} < V_{out}/2$. The inductor peak-to-peak ripple current increases if the switching frequency f_s decreases or if the inductance L decreases. A lower efficiency determines a decrease of the load current limit, as it involves higher losses and then a higher average inductor current. The values of f_s and L and V_{in} specified in Test#1 result in a load current limit at 12V higher than at 6V.

In Test#2 we are interested in investigating how the input voltage, the switching frequency, the inductance and the parasitic inductance of the current sensing resistor influence the current limit of the LM5122 boost regulator.

The discussion about the impact of the input voltage V_{in} , the switching frequency f_s and the inductance L on the load current limit relevant to TPS55340 boost regulator apply to LM5122 boost regulator as well. However, you may have observed that the load current limit threshold can get very low (down to $\approx 15\text{mA}$) when the inductor L_4 ($3.3\mu\text{H}$) is used, compared to the much higher load current limit threshold achieved when the inductor L_3 ($10\mu\text{H}$) is used (above 1.5A). This is the effect of the parasitic inductance L_{sns} of the current sensing resistor R_{11} . Indeed, as highlighted in the formula (6) provided in the *LM5122 current limit Theory Background* section, a smaller inductance L amplifies the voltage drop $V_{L_{sns}}$ across the parasitic inductance L_{sns} . With $L=3.3\mu\text{H}$ we have a voltage drop $V_{L_{sns}}$ three times greater than with $L=10\mu\text{H}$. With $L=10\mu\text{H}$, the voltage drop $V_{L_{sns}}$ across the parasitic inductance L_{sns} is not sufficiently large to cause the action of the current limit, and the load current can be high (see Figure 3(b) of *LM5122 current limit Theory Background* section). With $L = 3.3\mu\text{H}$, the voltage drop $V_{L_{sns}}$ gets large and the current limit is reached even with a small load current (see Figure 3(c) of *LM5122 current limit Theory Background* section).

[NOTE: If you want to increase the LM5122 boost regulator current limit threshold, it is sufficient that you solder a U-shape current shunt in parallel to the one mounted in the LM5122 board, as shown in Figure 11. If the additional shunt is identical to the one in the board, you reduce the parasitic inductance L_{sns} to one half and you can measure one half of the inductor current through each of them. As an alternative, you can solder a 2cm long wire, with 1mm to 2mm diameter, between the terminals of the U-shape current shunt mounted in the LM5122 board]

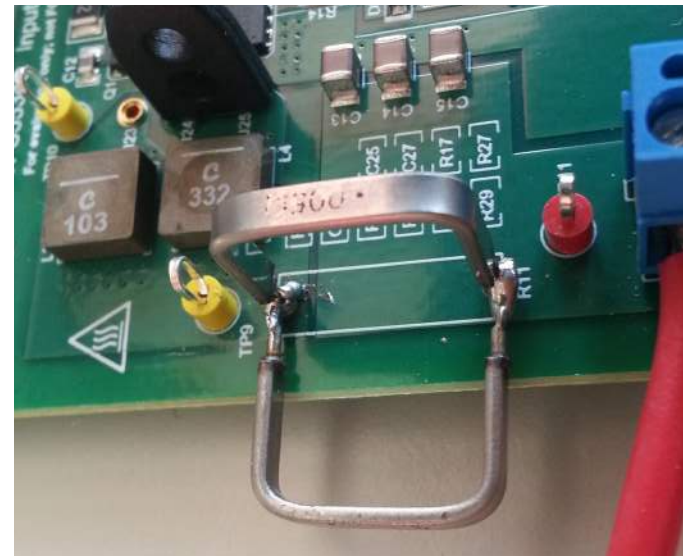

Figure 11



Experimental plots

The plots of Figures 12 to 15 show the results of experimental measurements performed on the TPS55340 boost regulator while detecting the load current limit.

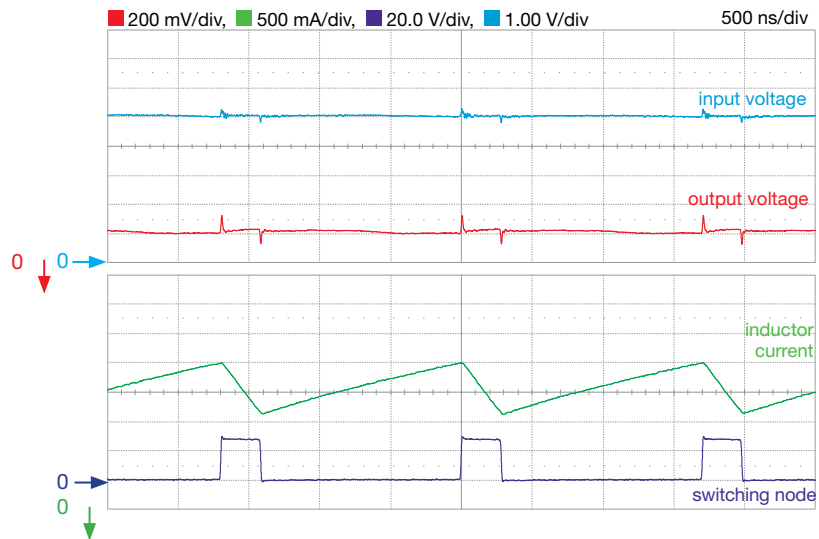

Figure 12. $V_{in}=5V$, $I_{out}=0.67A$, $f_s=600kHz$, $L=3.3\mu H$

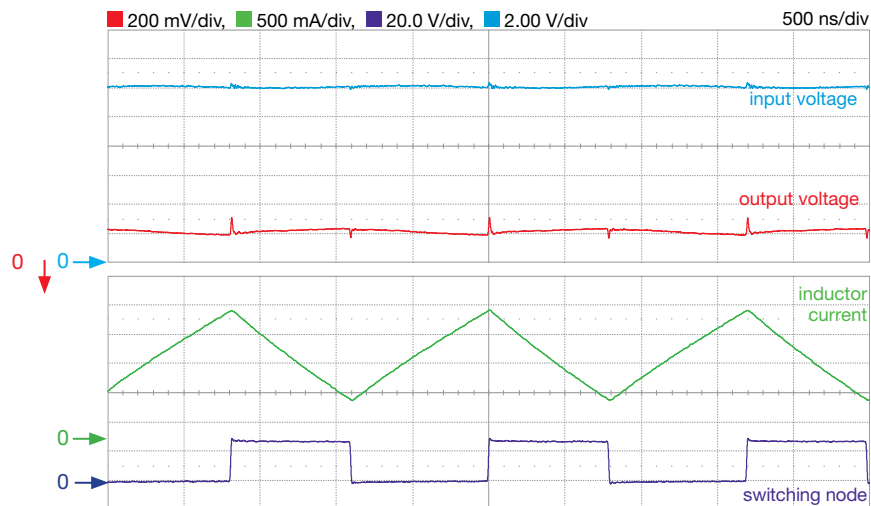

Figure 13. $V_{in}=12V$, $I_{out}=1.5A$, $f_s=600kHz$, $L=3.3\mu H$

The plots of Figures 12 and 13 compare the load current limit conditions detected with 5V input voltage and 12V input voltage for fixed values of the switching frequency f_s and of the inductance L . In the operating conditions of Figure 12, the average inductor current is about 3.30A (the zero reference of the green trace is out of the scope range) while the peak to peak ripple is about 1A, resulting in 0.67A load current limit. In the operating conditions of Figure 13, instead, the average inductor current is about 1.35A while the peak to peak to peak ripple is about 1.5A, resulting in 1.5A load current limit.



Experimental plots

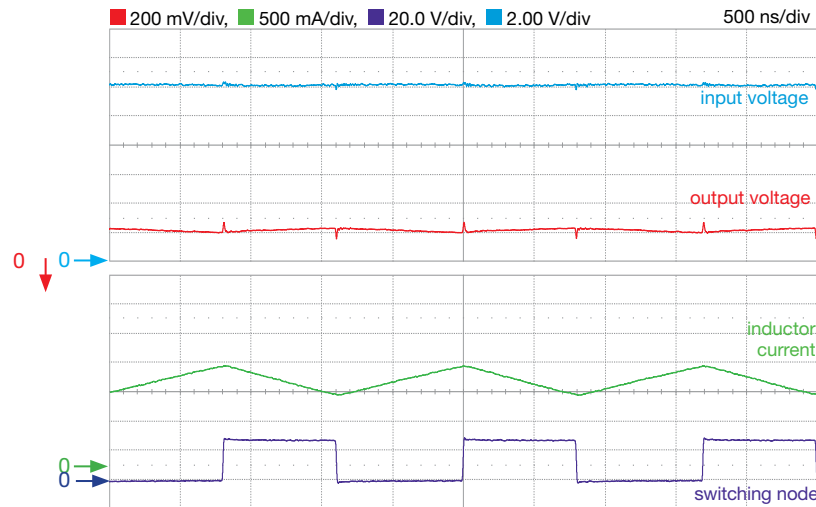

Figure 14. $V_{in}=12V$, $I_{out}=1.1A$, $f_s=600kHz$, $L=10\mu H$

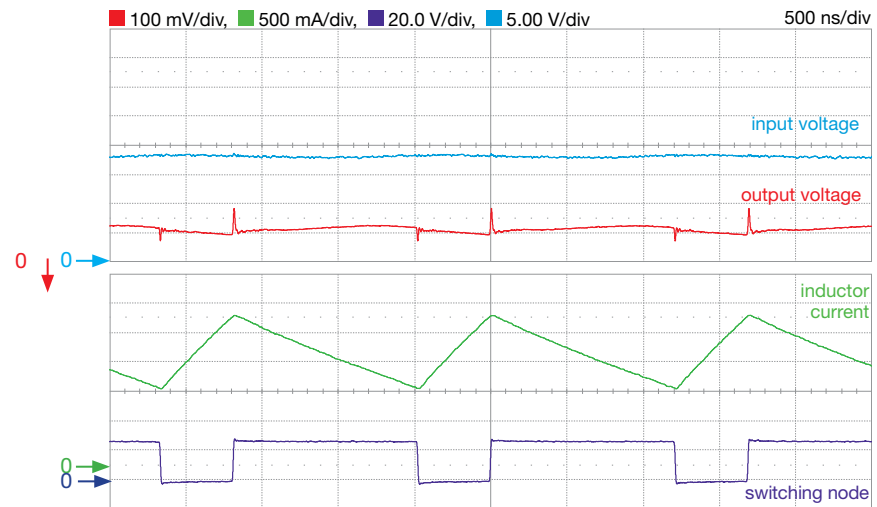

Figure 15. $V_{in}=18V$, $I_{out}=1.65A$, $f_s=600kHz$, $L=3.3\mu H$

The plots of Figures 14 and 15 compare the load current limit conditions detected with 12V input voltage and 18V input voltage for fixed values of the switching frequency f_s and two values of the inductance L . In the operating conditions of Figure 14, the average inductor current is about 1.35A (the zero reference of the green trace is out of the scope range) while the peak to peak ripple is about 0.5A, resulting in 1.10A load current limit. In the operating conditions of Figure 15, instead, the average inductor current is about 0.90A while the peak to peak ripple is about 1.25A, resulting in 1.65A load current limit.

[NOTES: 1) The load current limit is influenced by the temperature. The TPS55340 datasheet [5] provides the curve of inductor current limit vs temperature from which you can derive the load current limit based on formula (5) of the *TPS55340 current limit Theory Background* section. 2) The *Theory Background* section of *Experiment 3* highlights that the load current influences the voltage loop gain of the TPS55340 boost regulator. As a side exercise, given the input voltage V_{in} , the switching frequency f_s , the inductance L , and the error amplifier compensation, verify if there is a load current threshold value beyond which the TPS55340 becomes unstable]

Experiment 5

The goal of this experiment is to analyze how the operating conditions, the peak current control slope compensation and the voltage feedback compensation influence the line transient response of the boost converter. The LM5122 boost regulator is used in this experiment.



Case Study

The goal of this experiment is to analyze how the the load current, the current slope compensation setup and the voltage feedback compensation setup influence the line transient response of the boost converter.

The TI-PMLK LM5122 boost regulator operates with $V_{in}=[9,20]V^{(1)}$, while regulating the output voltage at the nominal value $V_{out}=24V$, $I_{out}=[0,2]A$. Figure 1 shows the basic circuit schematic. The power devices highlighted in the figure are: the input capacitor (C_{in}), the inductor (L), the output capacitor (C_{out}), the MOSFETs (Q_1, Q_2), the feedback compensation ($R_{fb1}, R_{fb2}, C_{f1}, R_{f2}, C_{f2}$), the current slope compensation resistor (R_{slope}) and the inductor current sensing resistor (R_s). A regulator has a good *line transient response* if the magnitude of the output voltage surges caused by the input voltage changes is small. The LM5122 boost regulator implements the Peak-Current Mode Control (PCMC), which provides good line voltage noise rejection, as it is characterized by an inherent feedforward feature. The Power Supply Rejection Ratio (PSRR) is a measure of the line noise rejection capability of a voltage regulator in the frequency domain. The PSRR is defined as the ratio between the output voltage perturbation ΔV_{out} and the input voltage perturbation ΔV_{in} as a function of the frequency f of the input voltage perturbation, $PSRR(f)=\Delta V_{out}(f)/\Delta V_{in}(f)$. The PSRR depends on the current-mode control setup, on the passive power components, on line/load operating conditions and on the voltage feedback error amplifier gain. If the PSRR is small, the line transient response is better.

⁽¹⁾ Restricted range adopted for this educational board, compared to the 4.5V to 65V full range of LM5122 [4]

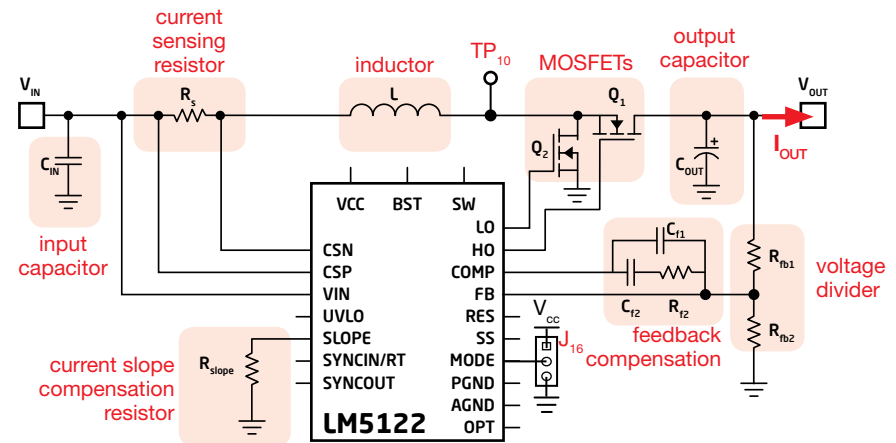

Figure 1. Simplified schematic of the LM5122 BOOST regulator

Test#1. We measure the magnitude of the output voltage surges caused by a change in the input voltage, at different load current conditions and with a different setup of the slope compensation of the current control loop. The voltage feedback compensation is changed to keep the crossover frequency high with the different slope compensation setup. The PSRR is calculated and its value is correlated with the output voltage surge magnitude. The goal is to analyze the impact of operating conditions and slope compensation on line transient response and correlate this with the PSRR formulae from the Theory Background.

Test#2. We measure the magnitude of the output voltage surges caused by a change in the input voltage, at different load current conditions and with a different setup of the voltage feedback compensation, providing different crossover with a given slope compensation setup. The PSRR is calculated and its value is correlated with the output voltage surge magnitude. The goal is to analyze the impact of operating conditions and feedback compensation on line transient response and correlate this with the PSRR formulae from the Theory Background.



Theory Background

The fundamentals of line transient response of peak-current controlled boost converter in CCM and its correlation with the PSRR are summarized below. (see [1][2][3][6] for more details on boost topology operation, dynamic modeling and current-mode control analysis and design; see [4] for more details on LM5122 operation and features)

Figure 2(b) shows the Peak Current Control (PCC) circuitry, while Figure 2(a) shows the PCC feedforward action, determining a rapid duty-cycle change when the input voltage changes.

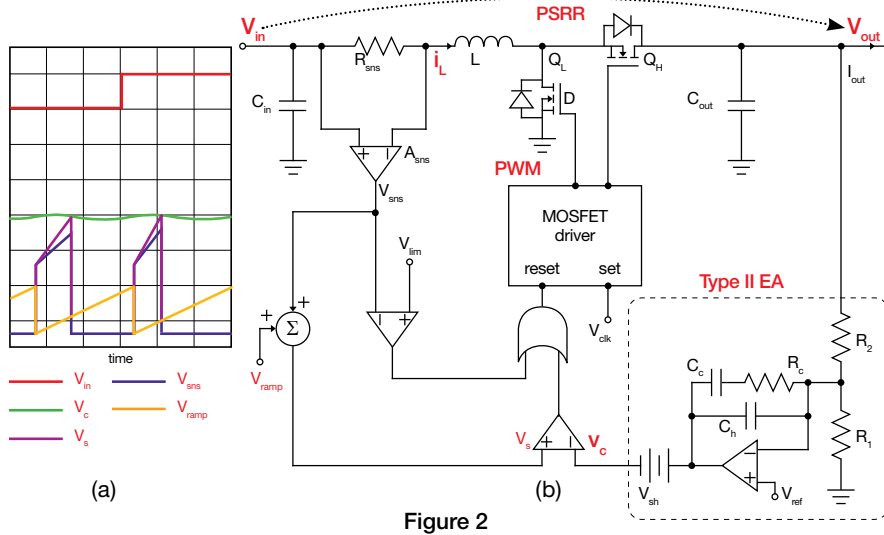

Figure 2

The PCC theory proves [6] that the PWM modulator law is given by (1):

$$(1) \quad \hat{d} = F_m [\hat{v}_c - A_s \hat{i}_L - F_v \hat{v}_{out}]$$

where the “^” means that the variable is the perturbation with respect to steady-state, and:

$$(2) \quad F_m = \frac{f_s}{s_e + s_n(1 - \frac{1}{2}M)}; A_s = R_{sns} A_{sns}; s_e = \frac{K_0 D}{R_{sl}}; s_n = \frac{A_s V_{in}}{L}; F_v = \frac{s_n D}{2f_s V_{out}}; M = \frac{V_{out}}{V_{in}}$$

From (1), the simplified *Control-to-Output* (CtO) gain $\hat{G}_{vc}(s)$ of PCMC boost can be obtained:

$$(3) \quad \hat{G}_{vc}(s) \cong \hat{G}_{vc0} \left[1 + \frac{s}{\omega_{ESR}} \right] \left[1 - \frac{s}{\omega_{RHP}} \right] \left[1 + \frac{s}{\omega_{LFP}} \right]^{-1} \left[1 + \frac{2s}{Q_s \omega_s} + \frac{4s^2}{\omega_s^2} \right]^{-1}; \hat{G}_{vc0} = \frac{V_{in}}{2I_{out} A_s}$$

where:

$$(4) \quad \omega_{ESR} = \frac{1}{ESR_{out} C_{out}}; \omega_{RHP} = \frac{V_{in}^2}{V_{out} I_{out} L}; \omega_{LFP} = \frac{2I_{out}}{C_{out} V_{out}}; Q_s = \frac{1}{\pi} \left[\frac{V_{in}}{V_{out}} \left(1 + \frac{s_e}{s_n} \right) - \frac{1}{2} \right]^{-1}$$

(1) for LM5122 it is $K_0 = 6 \cdot 10^9$

The gain of a Type II Error Amplifier (EA) (assuming ideal OP-AMP) is given by (5):

$$(5) \quad G_c(s) = \frac{\hat{v}_c}{\hat{v}_{out}} = \frac{\omega_0}{s} \left[1 + \frac{s}{\omega_z} \right] \left[1 + \frac{s}{\omega_p} \right]^{-1}; \omega_0 = \frac{1}{R_2(C_c + C_h)} = \frac{\omega_c}{K|G_{vc}(\omega_c)|}; \omega_z = \frac{1}{R_c C_c} = \frac{\omega_c}{K}; \omega_p = \frac{C_c + C_h}{R_2 C_c C_h} = \omega_c K$$

Merging the boost converter open-loop dynamic model [1] with the CtO gain of the peak-current controlled boost given by (3) and the Type II EA $G_c(s)$ gain given by (5) provides the explicit expression of the closed loop $PSRR(s) = \hat{v}_{out}/\hat{v}_{in}$ gain. The simplified form of the closed-loop PSRR at Low Frequency (LF) and High Frequency (HF) are given by (6):

$$(6) \quad PSRR_{LF} \cong s \frac{1 + A_s F_m I_{out} M^2}{F_m V_{out} \omega_0} = \frac{s}{\omega_{LF}}; \quad PSRR_{HF} \cong \frac{1}{s} \frac{V_{out} ESR (A_s F_m I_{out} M^2)}{LM [V_{out} + I_{out} ESR (1 - F_m V_{out} M)]} = \frac{\omega_{HF}}{s}$$

The formulae (6) show that:

- higher ω_{LF} means better $PSRR_{LF}$;
- smaller ω_{HF} means better $PSRR_{HF}$;
- the Error Amplifier influences the $PSRR_{LF}$ only;
- the ESR of the output capacitor influences the $PSRR_{HF}$ only;
- the slope compensation resistor R_{sl} and the line/load conditions influence the $PSRR$ globally.

Figure 3 shows the influence of R_{sl} on PSRR and line step response.

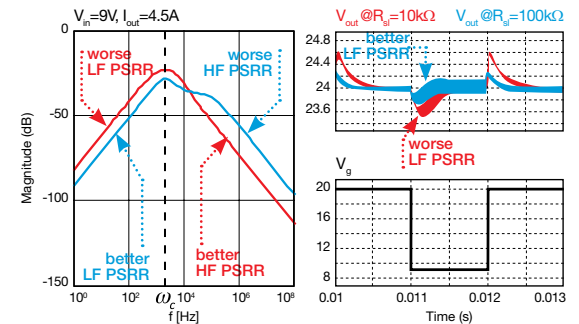

(a) PSRR Bode plots (b) line step response

Figure 3: --- $R_{sl} = 10k\Omega$; --- $R_{sl} = 100k\Omega$

Good to know

- The frequencies ω_0 , ω_p , ω_z of Type II error amplifier are determined from the desired closed loop cross-over frequency ω_c and phase margin ϕ_c : $\omega_0 = \omega_c / (|G_{vc}(\omega_c)|K)$, $\omega_z = \omega_c / K$, $\omega_p = \omega_c K$, where $K = \tan(\frac{1}{2}\phi_b + \frac{1}{4}\pi)$ and $\phi_b = \phi_c - 90^\circ - \angle G_{vc}(\omega_c)$ [1][2][3].
- The limited dc gain of a real OP-AMP makes the real $PSRR_{LF}$ flat.
- The sampling effect and the limited bandwidth of the OP-AMP influence the real $PSRR_{HF}$.
- The input capacitor and the line impedance influence the PSRR.



Experiment set-up: configuration

The instruments needed for this experiment are: a POWER SUPPLY with DC and DYNAMIC MODE options, a DC ELECTRONIC LOAD and an OSCILLOSCOPE. Figure 4 shows the instruments connections. Follow the instructions provided in next page to set-up the **connections**.

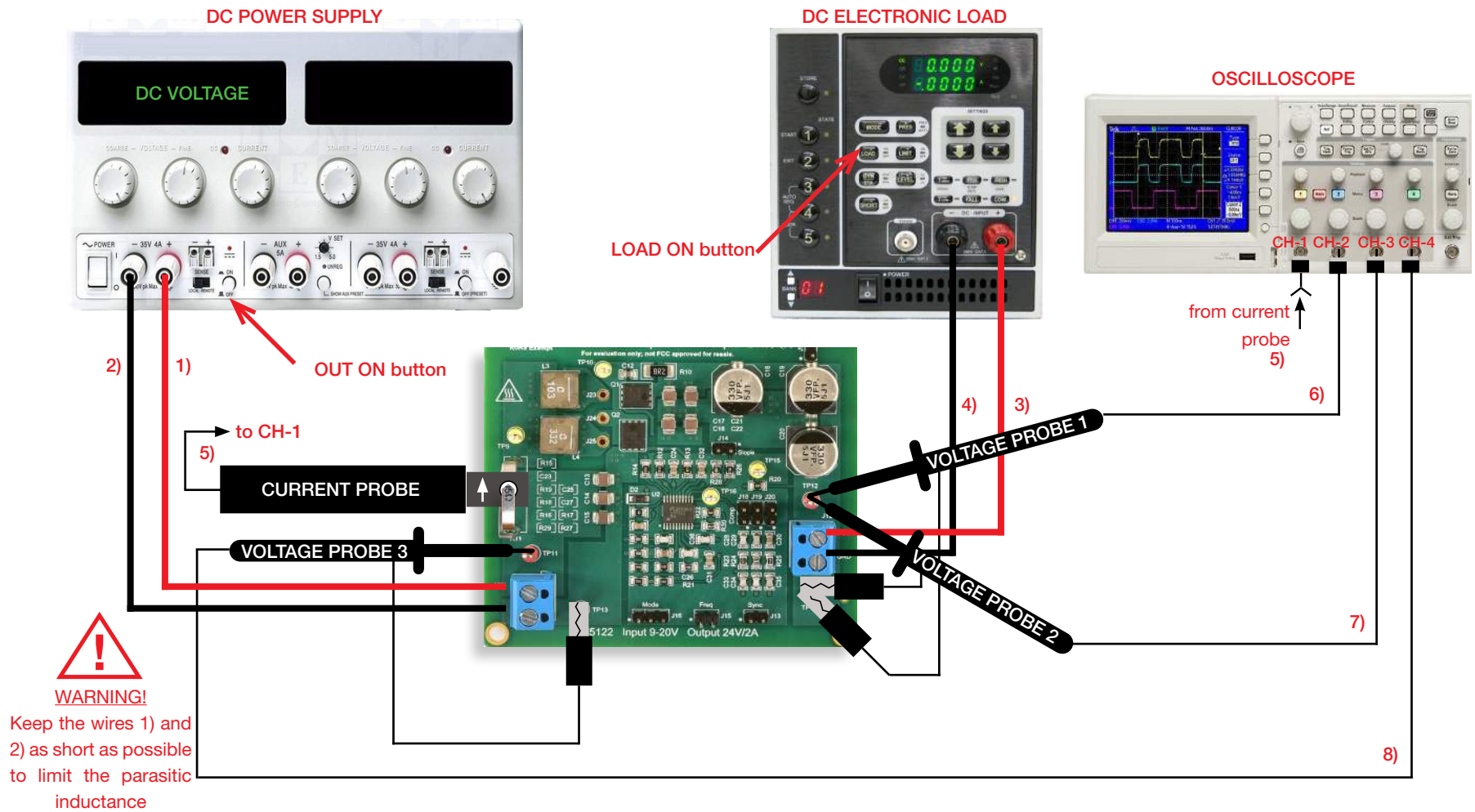

Figure 4. Experiment set-up.



Experiment set-up: instructions

With all the instruments turned off, make the following **connections**:

- 1) connect the POSITIVE (RED) OUTPUT of the DC POWER SUPPLY to the INPUT (VIN) of the J_{11} screw terminal of the LM5122 boost regulator
- 2) connect the NEGATIVE (BLACK) OUTPUT of the DC POWER SUPPLY to the GROUND (GND) of the J_{11} screw terminal of the LM5122 boost regulator
- 3) connect the OUTPUT (VOUT) of the J_{12} screw terminal of the LM5122 boost regulator to the POSITIVE (RED) INPUT of the ELECTRONIC LOAD
- 4) connect the GROUND (GND) of the J_{12} screw terminal of the LM5122 boost regulator to the NEGATIVE (BLACK) INPUT of the ELECTRONIC LOAD
- 5) connect a current probe to channel 1 of the OSCILLOSCOPE and hang it on the sensing resistor R_{11} of the LM5122 boost regulator, ensuring that the arrow printed on the probe clamps corresponds to the current that enters the inductor (the arrow must point upside when looking the LM5122 boost board frontally, as shown in Figure 5)
- 6) connect a voltage probe to channel 2 of the OSCILLOSCOPE, hang its positive tip to TEST PIN TP_{12} which is the output voltage of the LM5122 boost regulator. This probe will be used to measure the DC+AC components of the output voltage
[WARNING: DO NOT INVERT the positive and ground connections of the voltage probe]
- 7) connect a voltage probe to channel 3 of the OSCILLOSCOPE, hang its positive tip to TEST PIN TP_{12} which is the output voltage of the LM5122 boost regulator. This probe will be used to measure the AC component of the output voltage
[WARNING: DO NOT INVERT the positive and ground connections of the voltage probe]
- 8) connect a voltage probe to channel 4 of the OSCILLOSCOPE, hang its positive tip to TEST PIN TP_{11} which is the input voltage of the LM5122 boost regulator
[WARNING: DO NOT INVERT the positive and ground connections of the voltage probe]



Test#1: preparation and procedure

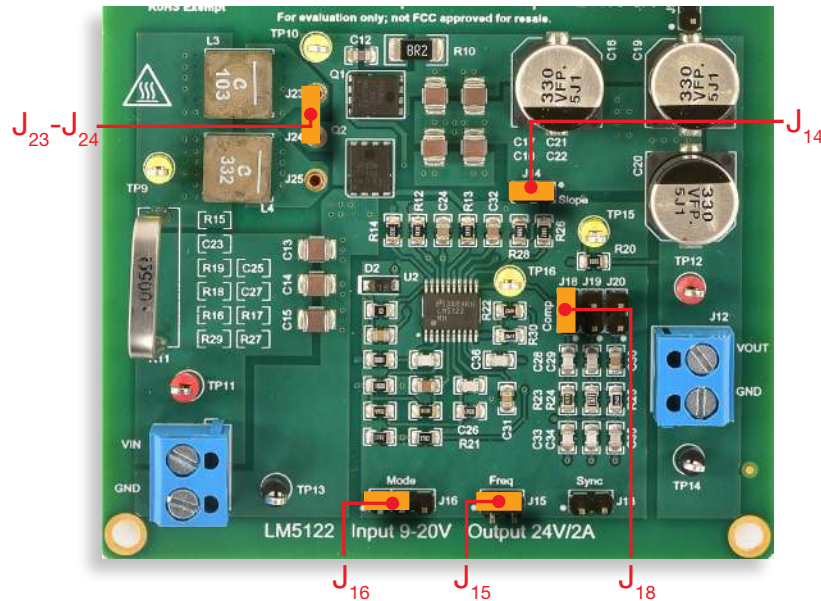

Figure 5. LM5122 board: jumpers set-up for Test#1

Initial jumpers set-up (see Figure 5):

- J_{13} open \rightarrow no external synchronization signal connected
- J_{14} shorted $\rightarrow R_{sl}=10k\Omega$ (high slope current mode compensation)
- J_{15} shorted \rightarrow switching frequency $f_s = 500kHz$
- J_{16} shorted left \rightarrow SOM setup
- J_{18} shorted, J_{19} open, J_{20} open \rightarrow error amplifier gain setup with parts R_{23} , C_{28} , C_{33} connected (high cross-over frequency with $L = L_3 = 10\mu H$, and high slope compensation ramp)
- $J_{23} - J_{24}$ shorted $\rightarrow L_3$ ($10\mu H$) inductor connected

Test Procedure:

- 1) turn on the OSCILLOSCOPE, set CH-1 in DC 50Ω coupling mode, set CH-3 and CH-4 in DC $1M\Omega$ coupling mode, set CH-2 in AC $1M\Omega$ coupling mode, select CH-4 as trigger source, and execute the “de-gauss” of the current probe to remove possible dc bias in the current probe.
- 2) turn on the POWER SUPPLY (ensure that the “OUT ON” button is OFF), set the DYNAMIC MODE, with a 250Hz, 50% duty-cycle square-wave voltage between 18V and 20V (you can adjust these values based on the features of the POWER SUPPLY, ensuring that the input voltage is limited within the 18V to 20V range) and set the CURRENT LIMIT at 4.5A
- 3) turn on the ELECTRONIC LOAD (ensure that the “LOAD ON” button is OFF), set the DC CURRENT at 0.5A
- 4) turn ON the POWER SUPPLY “OUT ON” button and the “LOAD ON” button of the ELECTRONIC LOAD. In these conditions you should see the DC+AC output voltage waveform on the CH-2 trace as a flat line around 24V level with small periodical surges, the AC component of the output voltage waveform on CH-3 trace as a flat line around 0V level with small periodical surges, the input voltage waveform on CH-4 trace as a square-wave between 18V and 20V, and the inductor current waveform on the CH-1 trace as a square-wave between about 0.6A and 2.5A (if the waveforms you see are much different than as described above, turn OFF the the “LOAD ON” button of the ELECTRONIC LOAD and the “OUT ON” button of the DC POWER SUPPLY and verify previous steps)
- 5) read the magnitude of the output voltage surges with cursor or measurement functions of the OSCILLOSCOPE, record the values in Table 1 and repeat this step for all the load current values listed in Table 1 (you do not need to turn OFF the POWER SUPPLY “OUT ON” button and the ELECTRONIC LOAD “LOAD ON” button while changing the load current)
- 6) turn OFF the the “LOAD ON” button of the ELECTRONIC LOAD and the “OUT ON” button of the DC POWER SUPPLY, open the jumper J_{14} to set the slope compensation resistance at $R_{sl}=100k\Omega$, open the jumper J_{18} and short the jumper J_{19} to set the voltage error amplifier at high crossover with small slope compensation, and repeat the steps 4) and 5)
- 7) at the end of the measurements, turn OFF the “LOAD ON” button of the ELECTRONIC LOAD and the “OUT ON” button of the DC POWER SUPPLY, then switch off all the instruments



Test#1: measure and calculate

For the operating conditions of Table 1:

- 1) measure the **peak output voltage overshoot and undershoot** with a dynamic voltage source connected to the input, imposing a 18V to 20V square-wave, and an adjustable DC load connected to the output
- 2) calculate the coefficients ω_{LF} and ω_{HF} of the PSRR formulae (6) provided in the *Theory Background* section
- 3) compare the magnitude of the output voltage line transient overshoot/undershoot with the magnitude of the coefficients ω_{LF} and ω_{HF} [**NOTE:** a higher ω_{LF} and a lower ω_{HF} improve the PSRR_{LF} and the PSRR_{HF}, respectively, and a better PSRR is expected to correspond to a smaller magnitude of line transient output voltage surges]

Table 1. Line transient response of LM5122 boost regulator with $f_s = 500\text{kHz}$, $L = 10\mu\text{H}$, SOM setup, and different slope compensation and load current setup

⁽¹⁾ ΔV_{out} [mV]	⁽²⁾ ω_{LF} [rad/s]	⁽³⁾ ω_{HF} [rad/s]	(a) high crossover (J_{18} sh, J_{19} op, J_{20} op) with high slope (J_{14} sh)									(b) high crossover (J_{18} op, J_{19} sh, J_{20} op) with low slope (J_{14} op)									
			$I_{out}=0.5\text{A}$			$I_{out}=1.0\text{A}$			$I_{out}=1.5\text{A}$			$I_{out}=0.5\text{A}$			$I_{out}=1.0\text{A}$			$I_{out}=1.5\text{A}$			
$V_{in}: 18\text{V} \rightarrow 20\text{V}^{(*)}$	(1)	(2)	(3)	(1)	(2)	(3)	(1)	(2)	(3)	(1)	(2)	(3)	(1)	(2)	(3)	(1)	(2)	(3)	(1)	(2)	(3)
$V_{in}: 20\text{V} \rightarrow 18\text{V}^{(*)}$	(1)	(2)	(3)	(1)	(2)	(3)	(1)	(2)	(3)	(1)	(2)	(3)	(1)	(2)	(3)	(1)	(2)	(3)	(1)	(2)	(3)

^(*) the extreme values 18V and 20V can be changed according to available power supply limitations. It is recommended to not exceed 2V peak-to-peak amplitude and to keep the minimum input voltage above 15V.

Feedback compensation components:

J_{18} sh, J_{19} op, J_{20} op: $R_c=R_{23}=169\Omega$, $C_c=C_{28}=1\text{nF}$, $C_h=C_{33}=27\text{pF}$; [high ω_c with $L=10\mu\text{H}$, $R_{sl}=10\text{k}\Omega$]
 J_{18} op, J_{19} sh, J_{20} op: $R_c=R_{24}=178\Omega$, $C_c=C_{29}=330\text{pF}$, $C_h=C_{34}=82\text{pF}$; [high ω_c with $L=10\mu\text{H}$, $R_{sl}=100\text{k}\Omega$]
 J_{18} op, J_{19} op, J_{20} sh: $R_c=R_{25}=24.3\text{k}\Omega$, $C_c=C_{30}=22\text{nF}$, $C_h=C_{35}=4.7\text{nF}$; [low ω_c with $L=10\mu\text{H}$, $R_{sl}=100\text{k}\Omega$]

Switching frequency:

J_{15} open $\rightarrow f_s = 250\text{kHz}$
 J_{15} shorted $\rightarrow f_s = 500\text{kHz}$

Current control slope compensation:

J_{14} open $\rightarrow R_{sl}=100.9\text{k}\Omega$ [low slope]
 J_{14} shorted $\rightarrow R_{sl}=10\text{k}\Omega$ [high slope]

Answer:

- 1 Does the magnitude of output voltage transient surges increase or decrease when the slope compensation increases?

increases decreases it depends on: _____

- 2 Is the magnitude of the coefficients ω_{LF} and ω_{HF} consistent with the magnitude of the output voltage surges?

yes no it depends on: _____

- 3 Are output voltage transient surges bigger for low load current or for high load current?

low load high load it depends on: _____



Test#2: preparation and procedure

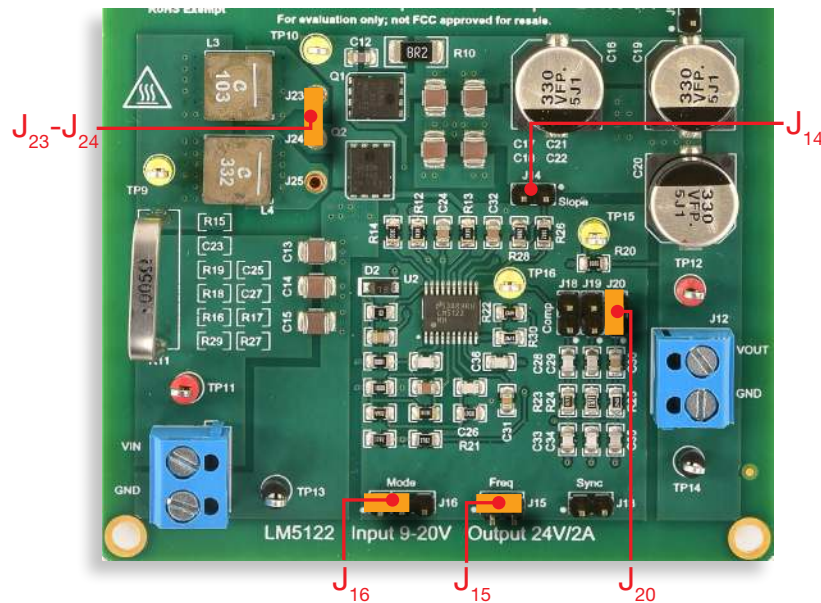

Figure 6. LM5122 board: jumpers set-up for Test#2

Initial jumpers set-up (see Figure 6):

- J_{13} open \rightarrow no external synchronization signal connected
- J_{14} open $\rightarrow R_{sl}=100k\Omega$ (low slope current mode compensation)
- J_{15} shorted \rightarrow switching frequency $f_s = 500kHz$
- J_{16} shorted left \rightarrow SOM setup
- J_{18} open, J_{19} open, J_{20} shorted \rightarrow error amplifier gain setup with parts R_{25} , C_{30} , C_{35} connected (low cross-over frequency with $L = L_3 = 10\mu H$, and small slope compensation ramp)
- $J_{23} - J_{24}$ shorted $\rightarrow L_3$ ($10\mu H$) inductor connected

Test Procedure:

- 1) turn on the OSCILLOSCOPE, set CH-1 in DC 50Ω coupling mode, set CH-3 and CH-4 in DC $1M\Omega$ coupling mode, set CH-2 in AC $1M\Omega$ coupling mode, select CH-4 as trigger source, and execute the “de-gauss” of the current probe to remove possible dc bias in the current probe.
- 2) turn on the POWER SUPPLY (ensure that the “OUT ON” button is OFF), set the DYNAMIC MODE, with a 250Hz, 50% duty-cycle square-wave voltage between 18V and 20V (you can adjust these values based on the features of the POWER SUPPLY, ensuring that the input voltage is limited within the 18V to 20V range), and set the CURRENT LIMIT at 4.5A
- 3) turn on the ELECTRONIC LOAD (ensure that the “LOAD ON” button is OFF), set the DC CURRENT at 0.5A
- 4) turn ON the POWER SUPPLY “OUT ON” button and the “LOAD ON” button of the ELECTRONIC LOAD. In these conditions you should see the DC+AC output voltage waveform on the CH-2 trace as a flat line around 24V level with small periodical surges, the AC component of the output voltage waveform on CH-3 trace as a flat line around 0V level with small periodical surges, the input voltage waveform on CH-4 trace as a square-wave between 18V and 20V, and the inductor current waveform on the CH-1 trace as a square-wave between about 0.6A and 2.5A (if the waveforms you see are much different than as described above, turn OFF the the “LOAD ON” button of the ELECTRONIC LOAD and the “OUT ON” button of the DC POWER SUPPLY and verify previous steps)
- 5) read the magnitude of the output voltage surges with cursor or measurement functions of the OSCILLOSCOPE, record the values in Table 1 and repeat this step for all the load current values listed in Table 1 (you do not need to turn OFF the POWER SUPPLY “OUT ON” button and the ELECTRONIC LOAD “LOAD ON” button while changing the load current)
- 6) turn OFF the the “LOAD ON” button of the ELECTRONIC LOAD and the “OUT ON” button of the DC POWER SUPPLY, open the jumper J_{20} and short the jumper J_{19} to set the voltage error amplifier at high crossover with small slope compensation, and repeat the steps 4) and 5)
- 7) at the end of the measurements, turn OFF the “LOAD ON” button of the ELECTRONIC LOAD and the “OUT ON” button of the DC POWER SUPPLY, then switch off all the instruments



Test#2: measure and calculate

For the operating conditions of Table 2:

- 1) measure the **peak output voltage overshoot and undershoot** with a dynamic voltage source connected to the input, imposing a 18V to 20V square-wave, and an adjustable DC load connected to the output
- 2) calculate the coefficients ω_{LF} and ω_{HF} of the PSRR formulae (6) provided in the *Theory Background* section
- 3) compare the magnitude of the output voltage line transient overshoot/undershoot with the magnitude of the coefficients ω_{LF} and ω_{HF} [**NOTE:** a higher ω_{LF} and a lower ω_{HF} improve the PSRR_{LF} and the PSRR_{HF}, respectively, and a better PSRR is expected to correspond to a smaller magnitude of line transient output voltage surges]

Table 2. Line transient response of LM5122 boost regulator with $f_s = 500\text{kHz}$, $R_{sl} = 100\text{k}\Omega$, $L = 10\mu\text{H}$, SOM setup, and different crossover and load current setup

(1) ΔV_{out} [mV]	(2) ω_{LF} [rad/s]	(3) ω_{HF} [rad/s]	(a) low crossover (J_{18} op, J_{19} op, J_{20} sh) with low slope (J_{14} sh)									(b) high crossover (J_{18} op, J_{19} sh, J_{20} op) with low slope (J_{14} sh)									
			$I_{out}=0.5\text{A}$			$I_{out}=1.0\text{A}$			$I_{out}=1.5\text{A}$			$I_{out}=0.5\text{A}$			$I_{out}=1.0\text{A}$			$I_{out}=1.5\text{A}$			
$V_{in}: 18\text{V} \rightarrow 20\text{V}^{(*)}$	(1)	(2)	(3)	(1)	(2)	(3)	(1)	(2)	(3)	(1)	(2)	(3)	(1)	(2)	(3)	(1)	(2)	(3)	(1)	(2)	(3)
$V_{in}: 20\text{V} \rightarrow 18\text{V}^{(*)}$	(1)	(2)	(3)	(1)	(2)	(3)	(1)	(2)	(3)	(1)	(2)	(3)	(1)	(2)	(3)	(1)	(2)	(3)	(1)	(2)	(3)

^(*) the extreme values 18V and 20V can be changed according to available power supply limitations. It is recommended to not exceed 2V peak-to-peak amplitude and to keep the minimum input voltage above 15V.

Feedback compensation components:

J_{18} sh, J_{19} op, J_{20} op: $R_c=R_{23}=169\Omega$, $C_c=C_{28}=1\text{nF}$, $C_h=C_{33}=27\text{pF}$; [high ω_c with $L=10\mu\text{H}$, $R_{sl}=10\text{k}\Omega$]
 J_{18} op, J_{19} sh, J_{20} op: $R_c=R_{24}=178\Omega$, $C_c=C_{29}=330\text{pF}$, $C_h=C_{34}=82\text{pF}$; [high ω_c with $L=10\mu\text{H}$, $R_{sl}=100\text{k}\Omega$]
 J_{18} op, J_{19} op, J_{20} sh: $R_c=R_{25}=24.3\text{k}\Omega$, $C_c=C_{30}=22\text{nF}$, $C_h=C_{35}=4.7\text{nF}$; [low ω_c with $L=10\mu\text{H}$, $R_{sl}=100\text{k}\Omega$]

Switching frequency:

J_{15} open $\rightarrow f_s = 250\text{kHz}$
 J_{15} shorted $\rightarrow f_s = 500\text{kHz}$

Current control slope compensation:

J_{14} open $\rightarrow R_{sl}=100.9\text{k}\Omega$ [low slope]
 J_{14} shorted $\rightarrow R_{sl}=10\text{k}\Omega$ [high slope]

Answer:

- 1 Does the magnitude of output voltage transient surges increase or decrease with lower crossover setup?

increases decreases it depends on: _____

- 2 Is the magnitude of the coefficients ω_{LF} and ω_{HF} consistent with the magnitude of the output voltage surges?

yes no it depends on: _____

- 3 Identify and discuss the combination of slope compensation, cross-over setup and load current which determines the best line transient performance and best PSRR:



Discussion

In Test#1 we are interested in investigating the impact of slope compensation on the line transient performance of the LM5122 boost regulator.

The formulae and the figures shown in the *Theory Background* section highlight how the boost regulator with peak current control reacts to input voltage perturbations and how the slope compensation impacts the PSRR and the corresponding time domain line transient response of the LM5122 boost regulator. Figure 2(a) shows the inherent feedforward action of the peak current control. In theory, should the input voltage change step-wise, the duty-cycle would immediately be adjusted in the subsequent switching cycle. In fact, the ramp signal V_s determines the duty-cycle when it intersects the control signal v_c generated by the error amplifier, as shown in Figure 2(a). The ramp signal V_s includes the compensation ramp V_{ramp} and the inductor current ramp signal V_{sns} , whose slope during the ON time of the MOSFET Q_2 is proportional to the input voltage. The consequent duty-cycle step change would then be followed by a transient response characterized by a rate of convergence to steady-state which is influenced by the voltage feedback error amplifier setup and by the current slope compensation setup. For a given error amplifier setup, the influence of the current slope compensation is shown by formulae (1), (2) and (6) and by Figure 3(a). Formulae (1) and (2) highlight that a higher slope resistance R_{si} determines a higher gain of the PWM current mode modulator F_m , which involves a higher sensitivity of the duty-cycle d to the perturbations of the inductor current i_L , control signal v_c and output voltage v_{out} . This means that the controller will rapidly react to the output voltage to the regulated steady-state value, as shown in the time domain line transient response plot of Figure 3(b). The Formula of $PSRR_{LF}$ (6) and the Bode plot of Figure 3(a) highlight the same concept in the frequency domain: the higher gain of the PWM current mode modulator F_m determined by a higher R_{si} value yields a lower $PSRR_{LF}$, which means a better capability of the PCC boost regulator to damp the effects of input voltage perturbations on the output voltage. In real world line transients, the input voltage never changes step-wise, but rather it rises or falls with a limited slew-rate, which is influenced by the output capacitance of the voltage source, by the line inductance and by the input capacitor of the boost regulator. Even more so, in this case the output voltage surges during line transient response are characterized by a smaller magnitude and a shorter duration thanks to the higher gain of the PWM current mode modulator F_m determined by a higher R_{si} value. It is worth remarking that a higher slope compensation resistance R_{si} determines an improvement as in the feedforward action of the peak current mode control as in the voltage feedback loop gain. The improvement of the feedforward action is determined by the fact that when R_{si} is higher, the magnitude of the current compensation ramp, represented in yellow in Figure 2(a), is smaller. As a consequence, the duty-cycle is more directly determined by the inductor current ramp signal V_{sns} whose slope is proportional to the input voltage. The slope of the compensation ramp has to be higher than a minimum threshold value to guarantee the stability of the current loop [6]. This limits the maximum value of the slope compensation resistance R_{si} .

In Test#2 we are interested in investigating the impact of the voltage loop gain crossover on the line transient performance of the LM5122 boost regulator.

The formulae and the figures shown in the *Theory Background* section highlight how the boost regulator with peak current control reacts to input voltage perturbations and how the voltage feedback error amplifier impacts the PSRR and the corresponding time domain line transient response of the LM5122 boost regulator. For a given current control slope compensation setup, a higher crossover ω_c involves a higher frequency $\omega_o = \omega_c / (K |G_{vc}(\omega_c)|)$ in the Error Amplifier gain $G_c(s)$ given by (5). Formulae (8) highlights that an error amplifier designed to achieve a higher crossover frequency ω_c determines a lower $PSRR_{LF}$, as it is inversely proportional to ω_o , as shown by formulae (8) and by Figure 3(a). As discussed above, a lower $PSRR_{LF}$ means a better capability of the PCC boost regulator in damping the effects of input voltage perturbations on the output voltage. Unlike a higher slope compensation resistance R_{si} , a higher crossover frequency ω_c does not improve the feedforward capability but only the voltage feedback loop gain.

Ultimately, the major improvements of the input disturbance rejection capability and of the line transient response of the a boost regulator are mostly determined by the inherent feedforward action of the peak current control, which can be maximized with a low slope compensation ramp. The voltage loop gain crossover frequency, instead, is more influential on the load transient response, which is the subject of *Experiment 6*.



Experimental plots

The plots of Figures 7 to 10 show the results of experimental measurements of the LM5122 boost regulator line transient response.

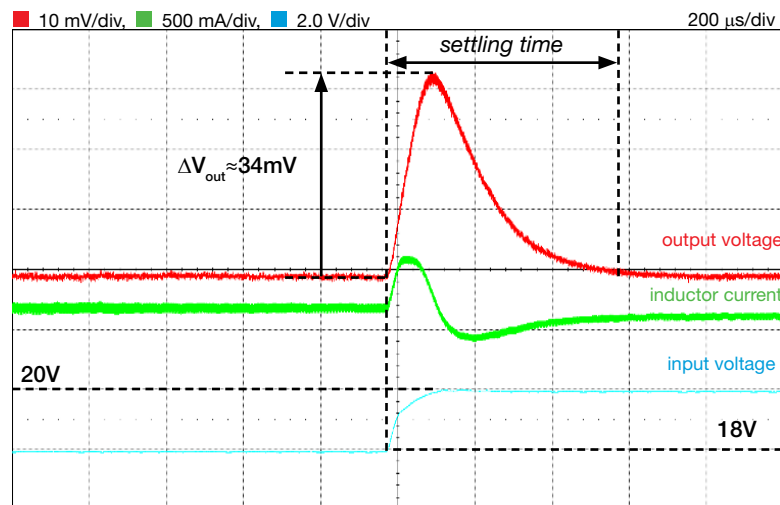

Figure 7. Line transient with high crossover loop gain and high slope compensation ramp: $V_{in}=18\text{V}$ to 20V , $I_{out}=0.5\text{A}$, $f_s=500\text{kHz}$, $L=10\mu\text{H}$

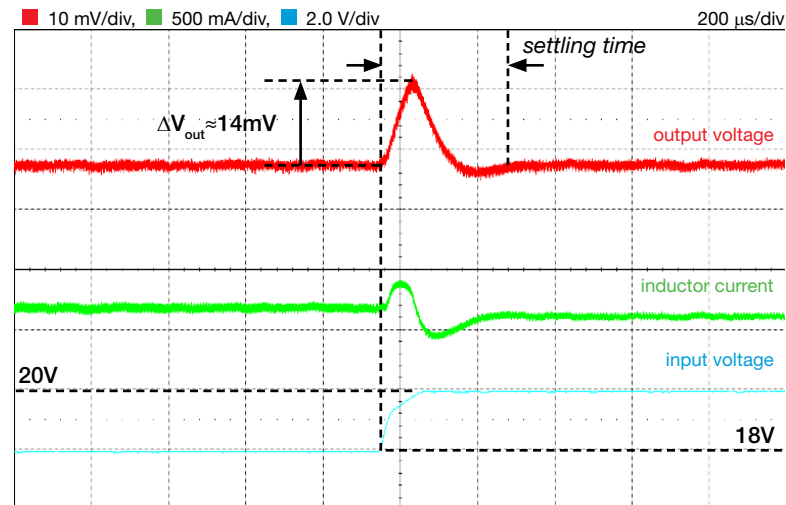

Figure 8. Line transient with high crossover loop gain and low slope compensation ramp: $V_{in}=18\text{V}$ to 20V , $I_{out}=0.5\text{A}$, $f_s=500\text{kHz}$, $L=10\mu\text{H}$

The plots of Figures 7 and 8 highlight the impact of the slope compensation setup on the line transient response of the LM5122 boost regulator, for a given load current and with a setup of the voltage feedback error amplifier such as to ensure high loop gain crossover in both cases. The magnitude of the output voltage surge is clearly smaller in Figure 8, corresponding to low slope compensation setup, compared to Figure 7, corresponding to high slope compensation setup. A low slope compensation setup also ensures a faster transient. Indeed, the time the controller takes to regulate the output voltage in the case of Figure 8 is shorter than the time the controller takes to regulate the output voltage in the case of Figure 7 (this is defined as *settling time*, which is the time elapsed from the application of the line voltage step change to the time from which the output voltage remains within a specified error band, e.g. 1% of the steady state regulated value).

[NOTE: the oscilloscope acquisitions shown in Figures 7 to 10 have been obtained with 20MHz bandwidth limit, +3bit digital filter and 10 sweeps average, to remove the switching frequency ripple]



Experimental plots

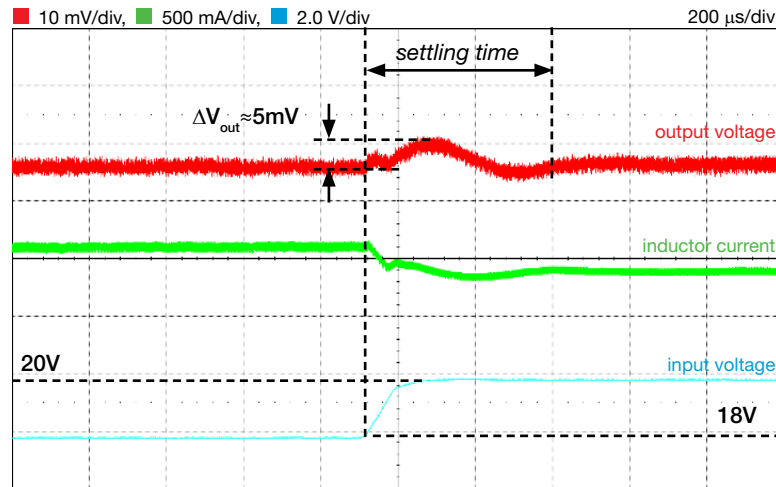

Figure 9. Line transient with high crossover loop gain and low slope compensation ramp: $V_{in}=18\text{V}$ to 20V , $I_{out}=1.5\text{A}$, $f_s=500\text{kHz}$, $L=10\mu\text{H}$

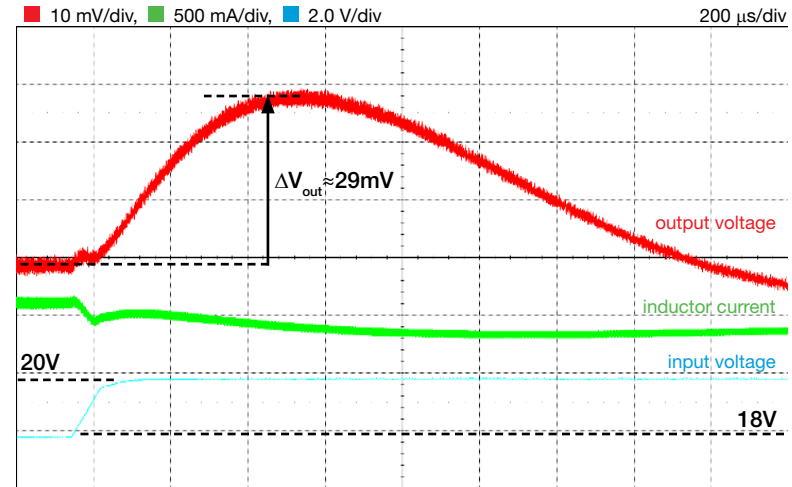

Figure 10. Line transient with low crossover loop gain and low slope compensation ramp: $V_{in}=18\text{V}$ to 20V , $I_{out}=1.5\text{A}$, $f_s=500\text{kHz}$, $L=10\mu\text{H}$

The plots of Figures 9 and 10 highlight the impact of the voltage feedback error amplifier setup on the line transient response of the LM5122 boost regulator, for a given load current and with a low slope compensation setup. The magnitude of the output voltage surge is clearly smaller in Figure 9, corresponding to a setup of the voltage feedback error amplifier ensuring a high crossover frequency of the loop gain, compared to Figure 10, corresponding to a setup of the voltage feedback error amplifier ensuring a low crossover frequency of the loop gain. The settling time in case of Figure 10 is also much longer (it falls beyond the scope) than the settling time in the case of Figure 9.

Experiment 6

The goal of this experiment is to analyze how the operating conditions, the peak current control slope compensation and the voltage feedback compensation influence the load transient response of the boost converter. The LM5122 boost regulator is used for this experiment.



Case Study

The goal of this experiment is to analyze how the input voltage, the current slope compensation setup and the voltage feedback compensation setup influence the load transient response of the boost converter.

The TI-PMLK LM5122 boost regulator operates with $V_{in}=[9,20]V^{(1)}$, while regulating the output voltage at the nominal value $V_{out}=24V$, $I_{out}=[0,2]A$. Figure 1 shows the basic circuit schematic. The power devices highlighted in the figure are: the input capacitor (C_{in}), the inductor (L), the output capacitor (C_{out}), the MOSFETs (Q_1, Q_2), the feedback compensation ($R_{fb1}, R_{fb2}, C_{f1}, R_{f2}, C_{f2}$), the current slope compensation resistor (R_{slope}) and the inductor current sensing resistor (R_s). The load transient response of a dc-dc regulator is important in all the applications where the load is expected to change rapidly. A regulator has a better *load transient response* if the magnitude of the output voltage surges caused by the load current changes is smaller. The **Output Impedance** of a regulator $OI(f)=-\Delta V_{out}(f)/\Delta I_{out}(f)$ is the ratio of the perturbations of the output voltage ΔV_{out} and the perturbation of the output current ΔI_{out} , as function of the frequency f of the output current perturbation. The $OI(f)$ function depends on the current-mode control setup, on the passive power components, on line/load operating conditions and on the voltage feedback error amplifier gain. If $OI(f)$ is small, the load transient response is good. The **reverse Power Supply Rejection Ratio** $rPSRR(f)=\Delta I_{in}(f)/\Delta I_{out}(f)$ provides a measure of how much the perturbations of the output current ΔI_{out} propagate backwards to the input current ΔI_{in} , as functions of the frequency f of the output current perturbation. The $rPSRR(f)$ is flat over the frequency range where the $OI(f)$ is small, so that a better load transient response (that is, having $OI(f)$ small over a wider frequency range) involves a lower load-to-line current noise rejection.

⁽¹⁾ Restricted range adopted for this educational board, compared to the 4.5V to 65V full range of LM5122 [4]

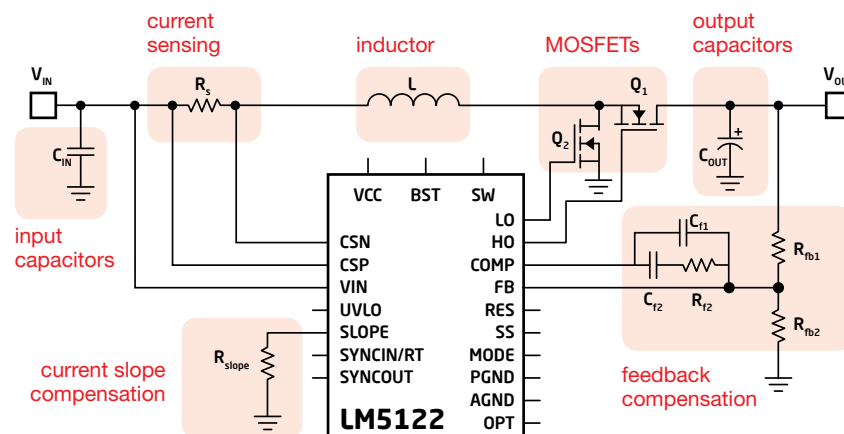

Figure 1. Simplified schematic of the LM5122 Boost regulator

Test#1. We measure the magnitude of the output voltage surges caused by a square-wave load current, at different input voltage and with different setup of the voltage feedback compensation, providing different crossover with a given slope compensation setup.

Test#2. We measure the magnitude of the output voltage surges caused by a square-wave load current, at different input voltage and with different setup of the slope compensation of the current control loop. The voltage feedback compensation is setup to keep the crossover frequency high with the different slope compensation setup.



Theory Background

The fundamentals of load transient response of peak-current controlled boost converter in CCM and its correlation with the output impedance and the reverse PSRR are discussed below (see [1][2][3] and [6] for more details on boost topology operation, dynamic modeling and current-mode control analysis and design; see [4] for more details on LM5122 operation and features)

Figure 2 shows the schematic of LM5122 boost regulator with the main elements of the peak-current control circuitry.

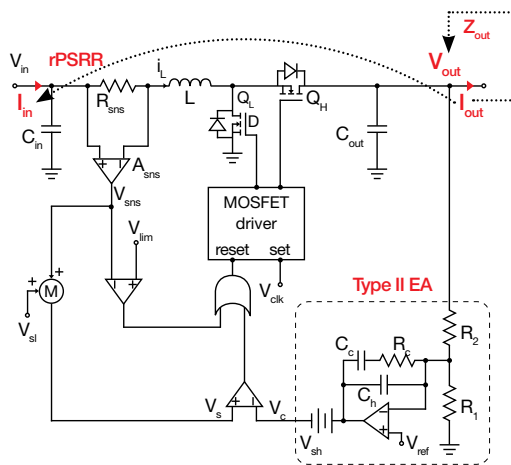

Figure 2

In some applications the load current can vary rapidly, nearly stepwise. The regulator has to attenuate the effects of such load changes, by limiting the magnitude of the output voltage overshoot/undershoot surges and the slew-rate of the input current, to comply with the required power supply specifications. The current loop and voltage loop play different roles in the achievement of these goals. The *Theory Background* section of *Experiment 5* provides the fundamentals to determine the closed loop frequency response of the LM5122 boost regulator to input line perturbations. The same procedure can

be applied to determine the Output Impedance $Z_{out}(s) = \hat{v}_{out} / \hat{i}_{out}$ at Low Frequency (LF) and High Frequency (HF) given by (1) (see *Experiment 5* for symbols):

$$(1) Z_{outLF} \cong s \frac{A_s M}{\omega_0} = \frac{s}{\omega_{LF}}; \quad Z_{outHF} \cong \frac{ESR}{1 + I_{out} ESR (1/V_{out} - F_m F_v M)}$$

where $M = V_{out} / V_{in}$. The factor ω_0 depends on the loop gain cross-over frequency (see *Experiment 5*), which is setup by the voltage feedback Error Amplifier (EA). The formula (1) shows that the EA influences Z_{outLF} , the ESR of the output capacitor and the current control slope compensation influence the Z_{outHF} , whereas the line and load conditions influence the Z_{out} globally. The reverse Power Supply Rejection Ratio $rPSRR(s) = \hat{i}_{in} / \hat{i}_{out}$ can be obtained in the same way. The formulae at Low Frequency (LF) and High Frequency (HF) are given by (2):

$$(2) rPSRR_{LF} = M, \quad rPSRR_{HF} \cong \frac{1}{s} \frac{V_{out} ESR (1 + F_v F_m V_{out} M)}{LM [V_{out} + I_{out} ESR (1 - F_m F_v M V_{out})]}$$

The formulae (2) show that the feedback Error Amplifier setup does not influence $rPSRR_{LF}$ and $rPSRR_{HF}$. Indeed the $rPSRR_{LF}$ is imposed by the voltage conversion ratio. The Error Amplifier setup determines the frequency below which the $rPSRR_{LF}$ (this is highlighted in Figure 4). The formulae (2) show that the ESR of the output capacitor and the current control slope compensation influence $rPSRR_{HF}$, whereas line/load operating conditions influence the $rPSRR$ globally. Figure 3 shows effects of crossover ω_c setup on Z_{out} and load step response: a higher ω_c improves the low frequency load noise rejection, whereas it does not influence high frequency noise rejection.

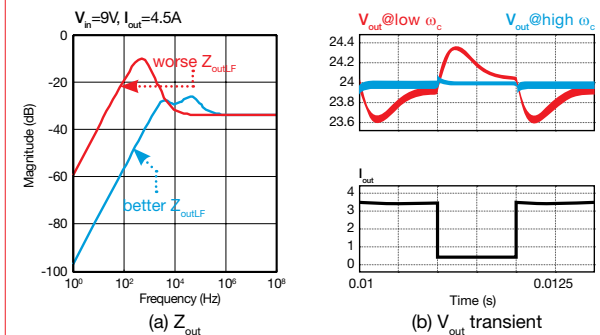

Figure 3: --- low crossover ω_c ; --- high crossover ω_c

Figure 4 shows that a higher ω_c expands the $rPSRR$ bandwidth whereas it does not influence low frequency noise rejection.

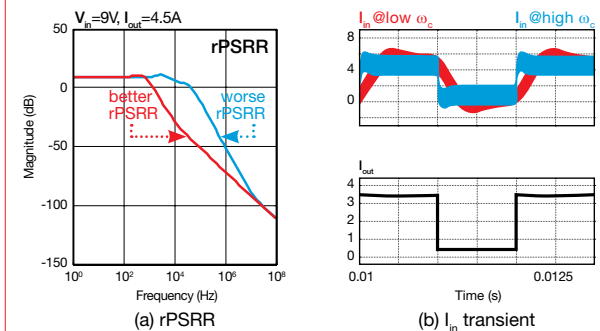

Figure 4: --- low crossover ω_c ; --- high crossover ω_c

Good to know:

The formulae (1) and (2) provided in this section are determined by using the model of the boost converter without the input capacitor. This allows to investigate the inherent load noise rejection capability of a peak-current mode controlled boost regulator. The formula shows that the crossover frequency determines the bandwidth of the line and load noises against which the voltage feedback Error Amplifier is able to immunize the output voltage V_{out} . The wider the bandwidth of load noise rejection required by V_{out} , the faster the reaction of the inductor has to be, and worse the $rPSRR$ gets. The input capacitor C_{in} helps in reducing the $rPSRR_{LF}$ bandwidth.



Experiment set-up: configuration

The instruments needed for this experiment are: a DC POWER SUPPLY, an ELECTRONIC LOAD with DYNAMIC MODE features and an OSCILLOSCOPE. Figure 5 shows the instruments connections. Follow the instructions provided in next page to set-up the **connections**.

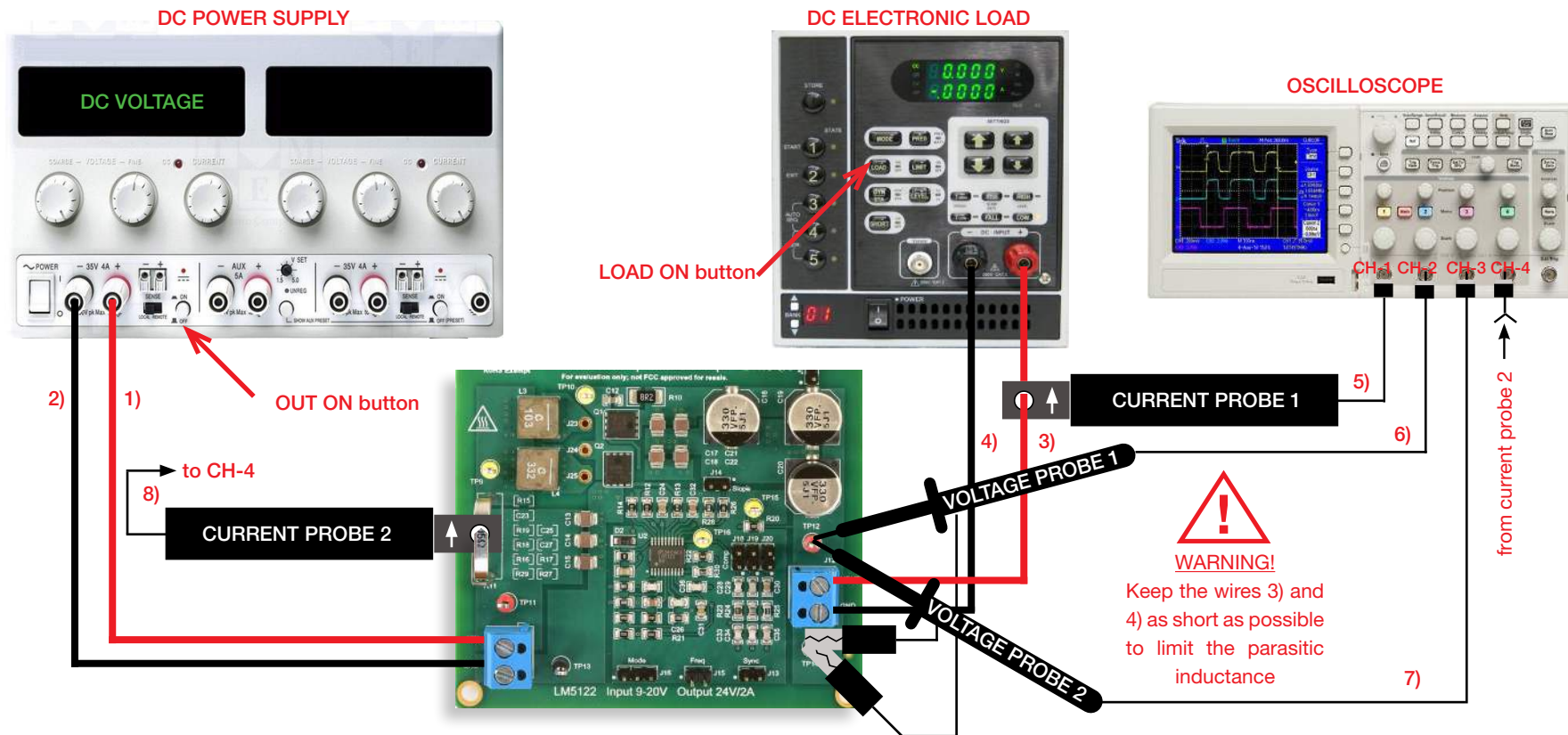

Figure 5. Experiment set-up.



Experiment set-up: instructions

With all the instruments turned off, make the following **connections**:

- 1) connect the POSITIVE (RED) OUTPUT of the DC POWER SUPPLY to the INPUT (VIN) of the J_{11} screw terminal of the LM5122 boost regulator
- 2) connect the NEGATIVE (BLACK) OUTPUT of the DC POWER SUPPLY to the GROUND (GND) of the J_{11} screw terminal of the LM5122 boost regulator
- 3) connect the OUTPUT (VOUT) of the J_{12} screw terminal of the LM5122 boost regulator to the POSITIVE (RED) INPUT of the ELECTRONIC LOAD
- 4) connect the GROUND (GND) of the J_{12} screw terminal of the LM5122 boost regulator to the NEGATIVE (BLACK) INPUT of the ELECTRONIC LOAD
- 5) connect a current probe to channel 1 of the OSCILLOSCOPE and hang it on the cable connecting the OUTPUT (VOUT) of the J_{12} screw terminal of the LM5122 boost regulator to the POSITIVE (RED) INPUT of the ELECTRONIC LOAD, ensuring that the arrow printed on the probe clamps corresponds to the current that enters the ELECTRONIC LOAD
- 6) connect a voltage probe to channel 2 of the OSCILLOSCOPE, hang its positive tip to TEST PIN TP_{12} which is the output voltage of the LM5122 boost regulator. This probe will be used to measure the DC+AC components of the output voltage
[WARNING: DO NOT INVERT the positive and ground connections of the voltage probe]
- 7) connect a voltage probe to channel 3 of the OSCILLOSCOPE, hang its positive tip to TEST PIN TP_{12} which is the output voltage of the LM5122 boost regulator. This probe will be used to measure the AC component of the output voltage
[WARNING: DO NOT INVERT the positive and ground connections of the voltage probe]
- 8) connect a current probe to channel 4 of the OSCILLOSCOPE and hang it on the sensing resistor R_{11} of the LM5122 boost regulator, ensuring that the arrow printed on the probe clamps corresponds to the current that enters the inductor (the arrow must point upside when looking the LM5122 boost board frontally, as shown in Figure 5)



Test#1: preparation and procedure

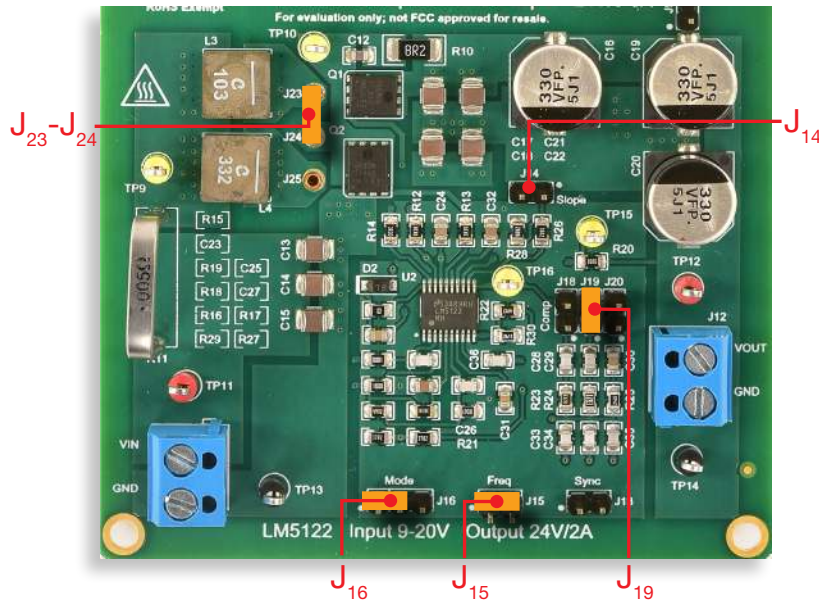

Figure 6. LM5122 board: jumpers set-up for Test#1

Initial jumpers set-up (see Figure 6):

- J_{13} open \rightarrow no external synchronization signal connected
- J_{14} open $\rightarrow R_{sl}=100k\Omega$ (low slope current mode compensation)
- J_{15} shorted \rightarrow switching frequency $f_s = 500kHz$
- J_{16} shorted left \rightarrow SOM setup
- J_{18} open, J_{19} shorted, J_{20} open \rightarrow error amplifier gain setup with parts R_{23} , C_{28} , C_{33} connected (high cross-over frequency with $L = L_3 = 10\mu H$, and low slope compensation ramp)
- $J_{23} - J_{24}$ shorted $\rightarrow L_3$ ($10\mu H$) inductor connected

Test Procedure:

- 1) turn on the OSCILLOSCOPE, set CH-1 and CH-4 in DC 50 Ω coupling mode, select CH-4 as trigger source, execute the “de-gauss” of the current probe to remove possible dc bias in the current probe, set CH-2 in DC 1M Ω coupling mode, CH-3 in AC 1M Ω coupling mode
- 2) turn on the POWER SUPPLY (ensure that the “OUT ON” button is OFF), set the DC VOLTAGE at 10V, and set the CURRENT LIMIT at 1A
- 3) turn on the ELECTRONIC LOAD (ensure that the “LOAD ON” button is OFF), set the DYNAMIC CURRENT MODE and fix the low current level at 100mA for 5ms, the high current level at 300mA for 5ms, the current rise and fall slew-rates at the highest level allowed by the instrument
- 4) turn ON the POWER SUPPLY “OUT ON” button. In these conditions you should see the load current on the CH-1 trace of the OSCILLOSCOPE as a flat waveform at zero level, the DC+AC components of the output voltage on the CH-2 trace as a flat waveform at 24V average value, the AC component of output voltage on CH-3 trace as a flat waveform at zero level, and the inductor current on CH-4 trace as a flat line at 0A level (if the waveforms do not look as described above, turn OFF the “OUT ON” button of the DC POWER SUPPLY and verify the previous steps)
- 5) turn ON the ELECTRONIC “LOAD ON” button. In these conditions you should see the load current on the CH-1 trace of the OSCILLOSCOPE as square-wave between 100mA and 300mA, the DC+AC components of the output voltage on the CH-2 trace as a waveform with 24V average value with small positive and negative surges at the instants of the load current steps, the AC component of output voltage on CH-3 trace as a flat waveform at zero level with small positive and negative surges at the instants of the load current steps, and the inductor current on CH-4 trace as a square-wave between 250mA and 750mA (if the waveforms do not look as described above, turn OFF the “OUT ON” button of the DC POWER SUPPLY and verify the previous steps)
- 6) record in Table 1 the magnitude of the output voltage surges after each load transient for the input voltage values listed in Table 1 (you do not need to turn OFF the POWER SUPPLY “OUT ON” button while adjusting the input voltage)
- 7) turn OFF the “LOAD ON” button of the ELECTRONIC LOAD and the “OUT ON” button of the DC POWER SUPPLY, then open the jumper J_{19} and short the jumper J_{19} to change the voltage feedback error amplifier setup, repeat the steps 4) to 6), and report the results in Table 1
- 8) at the end of the measurements, turn OFF the “LOAD ON” button of the ELECTRONIC LOAD and the “OUT ON” button of the DC POWER SUPPLY, then switch off all the instruments



Test#1: measure and calculate

For the operating conditions of Table 1:

- 1) measure the magnitudes of output voltage surges $\Delta V_{out,over}$ and $\Delta V_{out,under}$
- 2) calculate the factor $\omega_{LF} = \omega_o / (A_s M)$ of the output impedance $Z_{out,LF}$ given by formula (1) of the *Theory Background* section [NOTE: refer to the *Theory Background* section of *Experiment 5* to calculate the frequency factor ω_o as a function of the parameters of the feedback compensation components]
- 3) compare the magnitude of the load transient output voltage surges with the value of the frequency factor ω_{LF} [NOTE: a higher ω_{LF} makes the $Z_{out,LF}$ smaller, and this is expected to correspond to a smaller magnitude of load transient output voltage surges, that is a better load transient response]

Table 1. Output voltage load transient surges of the LM5122 boost regulator, with $f_s = 500\text{kHz}$, $L = 10\mu\text{H}$, low slope compensation, and different input voltage and feedback error amplifier setup

(a)	Input voltage	$I_{OUT}: 300\text{mA} \rightarrow 100\text{mA}$		$I_{OUT}: 100\text{mA} \rightarrow 300\text{mA}$	
$J_{18} \text{ op}$	$V_{in} = 10\text{V}$	$\Delta V_{OUT,over}$ [mV] =	ω_{LF} [rad/s] =	$\Delta V_{OUT,under}$ [mV] =	ω_{LF} [rad/s] =
$J_{19} \text{ sh}$	$V_{in} = 15\text{V}$	$\Delta V_{OUT,over}$ [mV] =	ω_{LF} [rad/s] =	$\Delta V_{OUT,under}$ [mV] =	ω_{LF} [rad/s] =
$J_{20} \text{ op}$	$V_{in} = 20\text{V}$	$\Delta V_{OUT,over}$ [mV] =	ω_{LF} [rad/s] =	$\Delta V_{OUT,under}$ [mV] =	ω_{LF} [rad/s] =
(b)	Input voltage	$I_{OUT}: 300\text{mA} \rightarrow 100\text{mA}$		$I_{OUT}: 100\text{mA} \rightarrow 300\text{mA}$	
$J_{18} \text{ op}$	$V_{in} = 10\text{V}$	$\Delta V_{OUT,over}$ [mV] =	ω_{LF} [rad/s] =	$\Delta V_{OUT,under}$ [mV] =	ω_{LF} [rad/s] =
$J_{19} \text{ op}$	$V_{in} = 15\text{V}$	$\Delta V_{OUT,over}$ [mV] =	ω_{LF} [rad/s] =	$\Delta V_{OUT,under}$ [mV] =	ω_{LF} [rad/s] =
$J_{20} \text{ sh}$	$V_{in} = 20\text{V}$	$\Delta V_{OUT,over}$ [mV] =	ω_{LF} [rad/s] =	$\Delta V_{OUT,under}$ [mV] =	ω_{LF} [rad/s] =

Feedback compensation components:

$J_{18} \text{ sh}, J_{19} \text{ op}, J_{20} \text{ op}$: $R_c = R_{23} = 169\Omega$, $C_c = C_{26} = 1\text{nF}$, $C_h = C_{33} = 27\text{pF}$; [high ω_c with $L = 10\mu\text{H}$, $R_{si} = 10\text{k}\Omega$]
 $J_{18} \text{ op}, J_{19} \text{ sh}, J_{20} \text{ op}$: $R_c = R_{24} = 178\Omega$, $C_c = C_{29} = 330\text{pF}$, $C_h = C_{34} = 82\text{pF}$; [high ω_c with $L = 10\mu\text{H}$, $R_{si} = 100\text{k}\Omega$]
 $J_{18} \text{ op}, J_{19} \text{ op}, J_{20} \text{ sh}$: $R_c = R_{25} = 24.3\text{k}\Omega$, $C_c = C_{30} = 22\text{nF}$, $C_h = C_{35} = 4.7\text{nF}$; [low ω_c with $L = 10\mu\text{H}$, $R_{si} = 100\text{k}\Omega$]

Switching frequency:

$J_{15} \text{ open} \rightarrow f_s = 250\text{kHz}$
 $J_{15} \text{ shorted} \rightarrow f_s = 500\text{kHz}$

Current control slope compensation:

$J_{14} \text{ open} \rightarrow R_{si} = 100.9\text{k}\Omega$ [low slope]
 $J_{14} \text{ shorted} \rightarrow R_{si} = 10\text{k}\Omega$ [high slope]

Answer:

- 1) Are the surges magnitude bigger for case (a) or for case (b) ? (a) (b) same it depends on: _____
- 2) Does the surges magnitude increase with the input voltage ? yes no it is insensitive other: _____
- 3) Is the magnitude of transient surges consistent with the value of ω_{LF} ? yes no it depends on: _____



Test#2: preparation and procedure

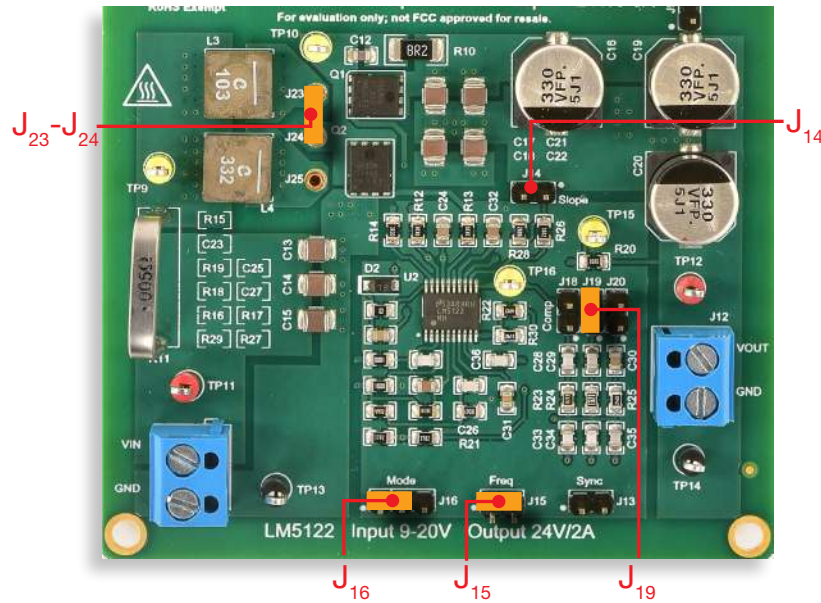

Figure 7. LM5122 board: jumpers set-up for Test#2

Initial jumpers set-up (see Figure 7):

- J_{13} open \rightarrow no external synchronization signal connected
- J_{14} open $\rightarrow R_{sl}=100k\Omega$ (low slope current mode compensation)
- J_{15} shorted \rightarrow switching frequency $f_s = 500kHz$
- J_{16} shorted left \rightarrow SOM setup
- J_{18} open, J_{19} shorted, J_{20} open \rightarrow error amplifier gain setup with parts R_{23} , C_{28} , C_{33} connected (high cross-over frequency with $L = L_3 = 10\mu H$, and low slope compensation ramp)
- $J_{23} - J_{24}$ shorted $\rightarrow L_3$ ($10\mu H$) inductor connected

Test Procedure:

- 1) turn on the OSCILLOSCOPE, set CH-1 and CH-4 in DC 50Ω coupling mode, select CH-4 as trigger source, execute the “de-gauss” of the current probe to remove possible dc bias in the current probe, set CH-2 in DC $1M\Omega$ coupling mode, CH-3 in AC $1M\Omega$ coupling mode
- 2) turn on the POWER SUPPLY (ensure that the “OUT ON” button is OFF), set the DC VOLTAGE at 10V, and set the CURRENT LIMIT at 1A
- 3) turn on the ELECTRONIC LOAD (ensure that the “LOAD ON” button is OFF), set the DYNAMIC CURRENT MODE and fix the low current level at 100mA for 5ms, the high current level at 300mA for 5ms, the current rise and fall slew-rates at the highest level allowed by the instrument
- 4) turn ON the POWER SUPPLY “OUT ON” button. In these conditions you should see the load current on the CH-1 trace of the OSCILLOSCOPE as a flat waveform at zero level, the DC+AC components of the output voltage on the CH-2 trace as a flat waveform at 24V average value, the AC component of output voltage on CH-3 trace as a flat waveform at zero level, and the inductor current on CH-4 trace as a flat line at 0A level (if the waveforms do not look as described above, turn OFF the “OUT ON” button of the DC POWER SUPPLY and verify the previous steps)
- 5) turn ON the ELECTRONIC “LOAD ON” button. In these conditions you should see the load current on the CH-1 trace of the OSCILLOSCOPE as square-wave between 100mA and 300mA, the DC+AC components of the output voltage on the CH-2 trace as a waveform with 24V average value with small positive and negative surges at the instants of the load current steps, the AC component of output voltage on CH-3 trace as a flat waveform at zero level with small positive and negative surges at the instants of the load current steps, and the inductor current on CH-4 trace as a square-wave between 250mA and 750mA (if the waveforms do not look as described above, turn OFF the “OUT ON” button of the DC POWER SUPPLY and verify the previous steps)
- 6) record in Table 1 the magnitude of the output voltage surges after each load transient for the input voltage values listed in Table 1 (you do not need to turn OFF the POWER SUPPLY “OUT ON” button while adjusting the input voltage)
- 7) turn OFF the “LOAD ON” button of the ELECTRONIC LOAD and the “OUT ON” button of the DC POWER SUPPLY, then short the jumper J_{14} to change the slope compensation setup, open the jumper J_{19} and short the jumper J_{18} to setup the voltage feedback error amplifier, repeat the steps 4) to 6), and report the results in Table 1
- 8) at the end of the measurements, turn OFF the “LOAD ON” button of the ELECTRONIC LOAD and the “OUT ON” button of the DC POWER SUPPLY, then switch off all the instruments



Test#2: measure and calculate

For the operating conditions of Table 2:

- 1) measure the magnitudes of output voltage surges $\Delta V_{out,over}$ and $\Delta V_{out,under}$
- 2) calculate the factor $\omega_{LF} = \omega_o / (A_s M)$ of the output impedance Z_{outLF} given by formula (1) of the *Theory Background* section [NOTE: refer to the *Theory Background* section of *Experiment 5* to calculate the frequency factor ω_o as a function of the parameters of the feedback compensation components]
- 3) compare the magnitude of the load transient output voltage surges with the value of the frequency factor ω_{LF} [NOTE: a higher ω_{LF} makes the Z_{outLF} smaller, and this is expected to correspond to a smaller magnitude of load transient output voltage surges, that is a better load transient response]

Table 1. Output voltage surges of the LM5122 boost regulator during load transients, with $f_s = 500\text{kHz}$, $L = 10\mu\text{H}$ and different input voltage and slope compensation setup⁽¹⁾

(a) $J_{14,op}$	Input voltage	$I_{OUT}: 300\text{mA} \rightarrow 100\text{mA}$		$I_{OUT}: 100\text{mA} \rightarrow 300\text{mA}$	
$J_{18,op}$	$V_{in}=10\text{V}$	$\Delta V_{OUT,over}$ [mV] =	ω_{LF} [rad/s] =	$\Delta V_{OUT,under}$ [mV] =	ω_{LF} [rad/s] =
$J_{19,sh}$	$V_{in}=15\text{V}$	$\Delta V_{OUT,over}$ [mV] =	ω_{LF} [rad/s] =	$\Delta V_{OUT,under}$ [mV] =	ω_{LF} [rad/s] =
$J_{20,op}$	$V_{in}=20\text{V}$	$\Delta V_{OUT,over}$ [mV] =	ω_{LF} [rad/s] =	$\Delta V_{OUT,under}$ [mV] =	ω_{LF} [rad/s] =
(b) $J_{14,sh}$	Input voltage	$I_{OUT}: 300\text{mA} \rightarrow 100\text{mA}$		$I_{OUT}: 100\text{mA} \rightarrow 300\text{mA}$	
$J_{18,sh}$	$V_{in}=10\text{V}$	$\Delta V_{OUT,over}$ [mV] =	ω_{LF} [rad/s] =	$\Delta V_{OUT,under}$ [mV] =	ω_{LF} [rad/s] =
$J_{19,op}$	$V_{in}=15\text{V}$	$\Delta V_{OUT,over}$ [mV] =	ω_{LF} [rad/s] =	$\Delta V_{OUT,under}$ [mV] =	ω_{LF} [rad/s] =
$J_{20,op}$	$V_{in}=20\text{V}$	$\Delta V_{OUT,over}$ [mV] =	ω_{LF} [rad/s] =	$\Delta V_{OUT,under}$ [mV] =	ω_{LF} [rad/s] =

⁽¹⁾ the error amplifier setup is changed too to ensure the crossover frequency does not change significantly.

Feedback compensation components:

$J_{18,sh}, J_{19,op}, J_{20,op}$: $R_c=R_{23}=169\Omega$, $C_c=C_{28}=1\text{nF}$, $C_h=C_{33}=27\text{pF}$; [high ω_c with $L=10\mu\text{H}$, $R_{si}=10\text{k}\Omega$]
 $J_{18,op}, J_{19,sh}, J_{20,op}$: $R_c=R_{24}=178\Omega$, $C_c=C_{29}=330\text{pF}$, $C_h=C_{34}=82\text{pF}$; [high ω_c with $L=10\mu\text{H}$, $R_{si}=100\text{k}\Omega$]
 $J_{18,op}, J_{19,op}, J_{20,sh}$: $R_c=R_{25}=24.3\text{k}\Omega$, $C_c=C_{30}=22\text{nF}$, $C_h=C_{35}=4.7\text{nF}$; [low ω_c with $L=10\mu\text{H}$, $R_{si}=100\text{k}\Omega$]

Switching frequency:

$J_{15,open} \rightarrow f_s = 250\text{kHz}$
 $J_{15,shorted} \rightarrow f_s = 500\text{kHz}$

Current control slope compensation:

$J_{14,open} \rightarrow R_{si}=100.9\text{k}\Omega$ [low slope]
 $J_{14,shorted} \rightarrow R_{si}=10\text{k}\Omega$ [high slope]

Answer:

- 1 Are the surges magnitude bigger for case (a) or for case (b) ? (a) (b) same it depends on: _____
- 2 Does the surges magnitude increase with the input voltage ? yes no it is insensitive other: _____
- 3 Is the magnitude of transient surges consistent with the value of ω_{LF} ? yes no it depends on: _____



Discussion

In Test#1 we are interested in investigating the impact of the voltage feedback loop gain crossover determined by the feedback error amplifier setup on the load transient performance of the LM5122 boost regulator

The formulae and the figures shown in the *Theory Background* section highlight how the boost regulator with peak current control reacts to load current perturbations and how the voltage feedback error amplifier setup impacts the output impedance Z_{out} gain and the corresponding time domain load transient response of the LM5122 boost regulator. Formulae (1) and Figure 3(a) show that the error amplifier setup mainly impacts the low frequency output impedance Z_{outLF} , which is improved by a higher crossover frequency ω_c . Improved load perturbation rejection capability is shown in Figure 3(b) due to higher crossover frequency setup. The cross-over frequency of the boost regulator voltage loop gain is determined by the poles and zeros of the feedback compensation error amplifier. If the poles and zeros of the error amplifier are placed so as to set a higher crossover frequency, its gain will have a higher magnitude over a wider frequency range. This involves that the effects of load perturbances are more strongly magnified by the error amplifier, by changing more intensely its output voltage v_e , which is the reference or the peak inductor current. Thus, a higher crossover determines a faster adaptation of the inductor current to the load demand and ensures a faster response of the boost regulator to load transients. In particular, the magnitude of the output voltage transient surges is smaller as the boost regulator reacts faster to the load perturbation and this shortens the duration of the time interval wherein the output capacitor has to sustain the unbalance between the instant power transferred from the input to the load through the inductor and the load power demand. Although a higher crossover frequency has beneficial effects on load transient performance, its value cannot be too high for two reasons. A first absolute limit that cannot be exceeded is determined by the switching frequency. In fact, a crossover frequency higher than the switching frequency is not allowed, as in that case the error amplifier would try to damp the switching ripple of the output voltage, which is not a disturbance determined by load variations but rather the beat of the converter. The ripple limiting, in fact, is achieved by means of an adequate output capacitor. The second limit for the crossover frequency is determined by the couple of poles introduced in the voltage loop gain at half the switching as a consequence of the sampling mechanism characterizing the peak current mode control [6]. These poles introduce a phase lag which depends on the slope of the compensation ramp and that increases while approaching half the switching frequency, where it becomes -90° . In theory, a Type III error amplifier could provide the due phase boost to achieve the desired phase margin. However, the global asymptotic stability requirement imposes that the phase of the loop gain is greater than -180° from DC to the crossover frequency. Thus, a high crossover frequency and global asymptotic stability could not be jointly achievable, and the design of an error amplifier intended to achieve a crossover frequency too close to one half of the switching frequency can be unfeasible with a Type II and even with a Type III error amplifier. Formulae (1) also highlight that high frequency output impedance Z_{outH} is dominated by the ESR of the output capacitor and is not influenced by the error amplifier. In fact, should the load perturbation be characterized by a frequency higher than the crossover, the feedback controller would not be able to follow and compensate it. Therefore, a low ESR is required to keep low the high frequency output impedance and limit the magnitude of the output voltage surges determined by high slew-rate load transients.

In Test#2 we are interested in investigating the impact of the peak current control modulator gain determined by the slope compensation setup on the load transient performance of the LM5122 boost regulator

The formulae (1) shown in the *Theory Background* section highlight that the slope compensation setup does not directly impact the low frequency output impedance Z_{outLF} , whereas it has a minor influence on the high frequency output impedance Z_{outHF} .

Ultimately, the major improvements of the load disturbance rejection capability and of the load transient response of the a boost regulator are mostly determined by the voltage feedback error amplifier setup, and are maximized by a high voltage loop gain crossover frequency. The slope compensation setup, instead, is more influential on the line transient response, which is the subject of *Experiment 5*.



Experimental plots

The plots of Figures 8 to 11 show some examples of experimental measurements of LM5122 boost regulator load transient response.

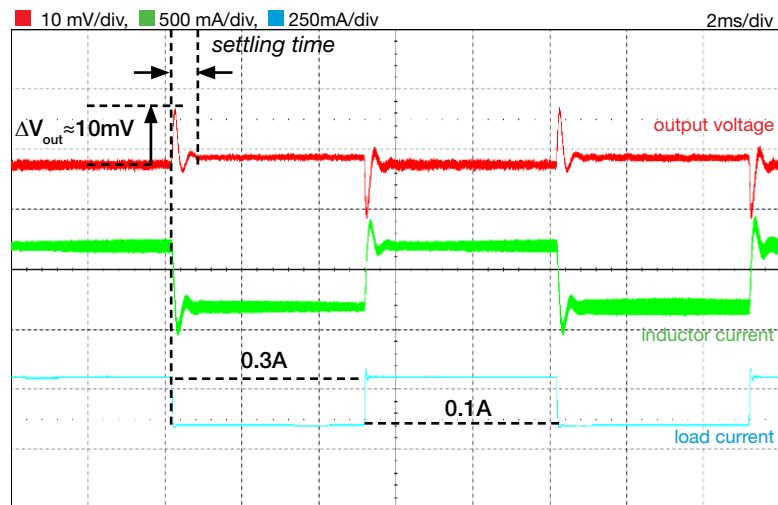

Figure 8. Load transient response with high crossover frequency loop gain and low slope compensation ramp: $V_{in}=10V$, $I_{out}=0.1A$ to $0.3A$, $f_s=500kHz$, $L=10\mu H$

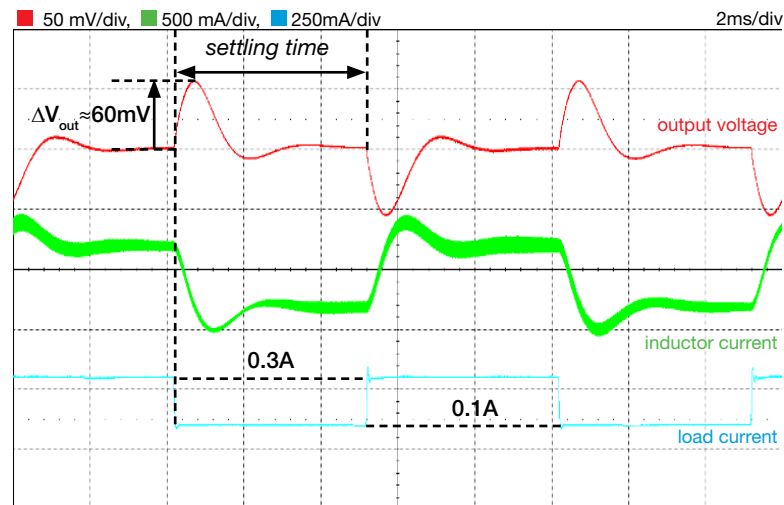

Figure 9. Load transient response with low crossover frequency loop gain and low slope compensation ramp: $V_{in}=10V$, $I_{out}=0.1A$ to $0.3A$, $f_s=500kHz$, $L=10\mu H$

The plots of Figures 8 and 9 show the impact of the loop gain crossover frequency on the load transient response, for given input voltage and low slope compensation setup. The magnitude of the output voltage surge is clearly smaller in Figure 8, corresponding to high crossover frequency setup, compared to Figure 9, corresponding to low crossover frequency setup. A higher crossover frequency also ensures a faster transient. Indeed, the time the controller takes to regulate the output voltage in the case of Figure 8 is much shorter than the time the controller takes to regulate the output voltage in the case of Figure 9 (this is defined as *settling time*, which is the time elapsed from the application of the load current step to the time from which the output voltage remains within a specified error band, e.g. 1% of the steady state regulated value). The inductor transient waveform allows to highlight the impact of the crossover frequency setup on the reverse PSRR, discussed in the *Theory Background* section. In fact, the plot of Figure 8 shows that the waveform of the inductor current (green trace) looks like a square wave similar to the load current square wave. This means that under conditions of high crossover frequency, the high frequency noise easily propagates to the input side, as the inductor is on the input side in the boost converter. Then, a higher input capacitance is required to limit the line current load transient slew-rate. The plot of Figure 9, instead, shows that the inductor current waveform has a smoother transition from low to high level and viceversa, which means that with low crossover frequency the square wave load current is better filtered towards the input line. In these conditions, a smaller input capacitor is required to limit the line current load transient slew-rate.

[NOTE: the oscilloscope acquisitions shown in Figures 8 to 11 have been obtained with 20MHz bandwidth limit, +3bit digital filter and 10 sweeps average, to remove the switching frequency ripple]



Experimental plots

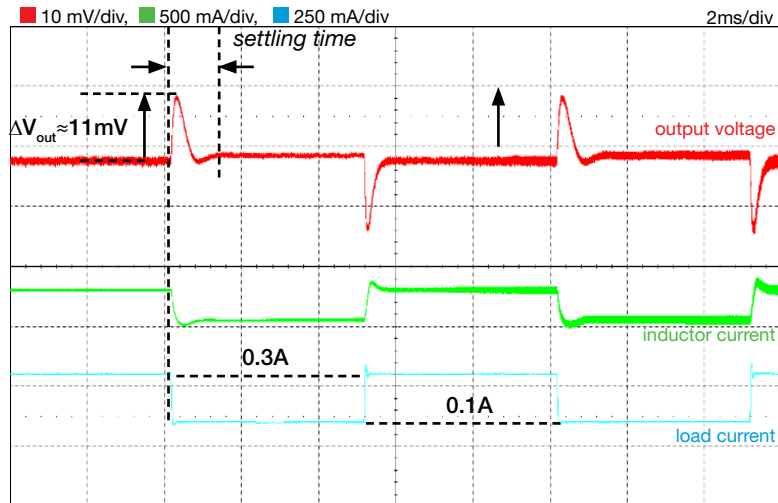

Figure 10. Load transient response with high crossover frequency loop gain and high slope compensation ramp: $V_{in}=20V$, $I_{out}=0.1A$ to $0.3A$, $f_s=500kHz$, $L=10\mu H$

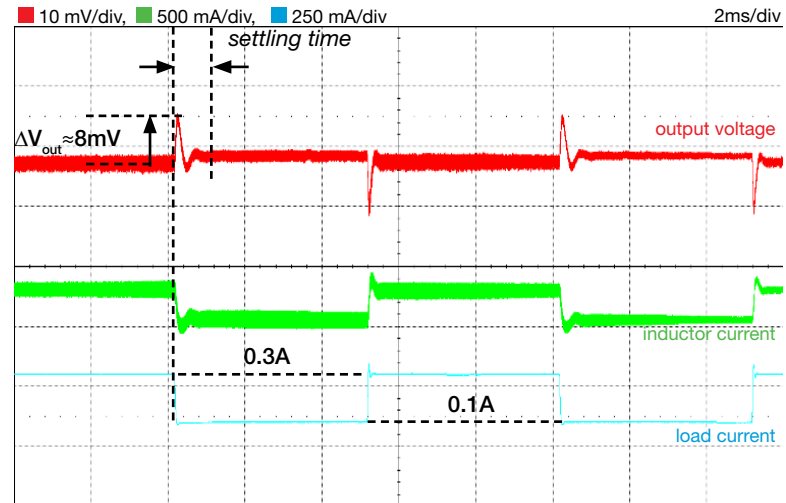

Figure 11. Load transient response with high crossover frequency loop gain and low slope compensation ramp: $V_{in}=20V$, $I_{out}=0.1A$ to $0.3A$, $f_s=500kHz$, $L=10\mu H$

The plots of Figures 10 and 11 show the impact of the compensation slope on the boost regulator load transient response, for given input voltage and crossover frequency setup. The magnitude of the output voltage surge is clearly smaller in Figure 11, corresponding to low slope compensation setup, compared to Figure 10, corresponding to high slope compensation setup. The settling time in the case of Figure 11 is slightly shorter than the settling time in the case of Figure 10. The high crossover frequency ensures a fast load transient response in both cases.

Appendix A

References

- [1] R.W. Erickson, D.Maksimovic, Fundamentals of Power Electronics, Springer
- [2] S.Maniktala, Switching Power Supplies A - Z, Newness
- [3] C.Basso, Designing Control Loops for Linear and Switching Power Supplies: A Tutorial Guide, Artech House
- [4] LM5122 datasheet, <http://www.ti.com/lit/ds/symlink/LM5122.pdf>
- [5] TPS55340 datasheet, <http://www.ti.com/lit/ds/symlink/TPS55340.pdf>
- [6] F.D. Tan, R.D. Middlebrook: "A unified model for current-programmed converters", IEEE Trans. on Power Electronics, 1995, Vol.10, No.4, pp. 397 - 408.

Appendix B

Manufacturers websites

ASJ,	http://www.asj.com.sg/
AVX,	http://www.avx.com/
Bourns,	http://www.bourns.com
Coilcraft,	http://www.coilcraft.com/
Diodes Incorporated,	http://www.diodes.com/
Kemet,	http://www.kemet.com/
Murata,	http://www.murata.com/
Nippon Chemi-Con,	http://www.chemi-con.co.jp/
ON Semiconductor,	http://www.onsemi.com/
Panasonic,	http://industrial.panasonic.com/
Philips Lumileds,	http://www.philipslumileds.com/
Rohm Semiconductor,	http://www.rohm.com/
Samsung,	http://www.samsungsem.com/
Samwha,	http://www.samwha.com/
Taiyo Yuden,	http://www.t-yuden.com/
TDK,	http://product.tdk.com/
TE Connectivity,	http://www.te.com/
Texas Instruments,	http://www.ti.com/
TT Electronics,	http://www.ttelectronics.com
Vishay,	http://www.vishay.com/
Yageo,	http://www.yageo.com/

Tluniversityprogram

Texas Instruments has been passionate about creating innovative technology solutions for more than 80 years. The TI University Program was established in 1982 and is a global program operating in 35 countries, multiple languages and impacting over hundreds of thousands of students every year. The TI University Program offers educators discounted tools, lab donations, and teaching materials so students can learn TI technology in the classroom and lab. From teaching materials to design projects, our advanced analog and embedded processing technologies fuel the passions of students and educators in university labs worldwide.

TI-PMLK: Powered by Coilcraft

Coilcraft is the exclusive inductor supplier for all TI-PMLK Educational boards.

Specified parts include:

- **MSS1278-103MLB**
MSS1278 Series Shielded Surface Mount Power Inductors
- **MSS1246T-332MLB**
MSS1246T Series High Temperature Power Inductors
- **XAL7030-103MEB**
XAL7030 Series High Current Shielded Power Inductors
- **XAL7030-332MEB**
XAL7030 Series High Current Shielded Power Inductors

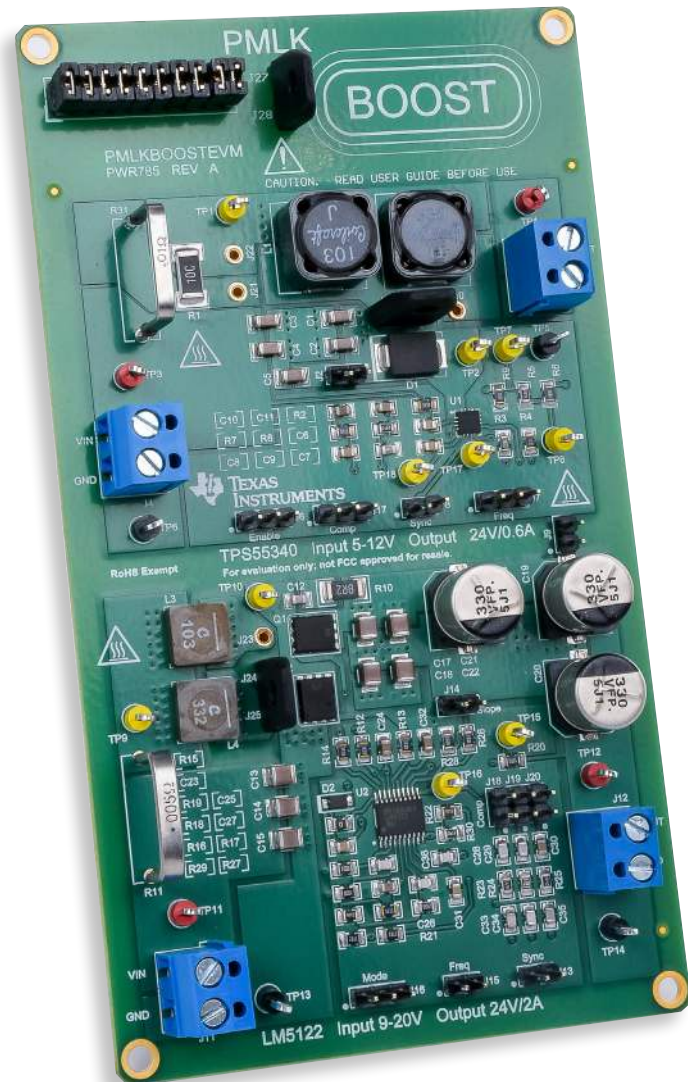

Coilcraft is your RF & Power Magnetic resource



Coilcraft understands that inductors can be difficult for students to understand, so we're committed to supporting you with the same tools and resources professional engineers rely on when designing power management and analog circuits.

Free product samples



Need some Coilcraft parts for your design project? We'll ship them today.

Industry's best design tools



Our powerful on-line tools will lead you to the perfect part quickly and easily.

Application notes



Our App Notes and Design Guides cover topics you might not learn about in class.

Free Power Management Lab Kit



This free parts tool kit helps instructors bring practical experience into the classroom.



Learn more @ [Coilcraft.com/students](https://www.coilcraft.com/students)

IMPORTANT NOTICE

TI Power Management Lab Kit (“TI-PMLK”) – Boost Experiment Book is intended to introduce students to basic electronic theory and circuits through experiments outlined in this book. While Texas Instruments Incorporated and its subsidiaries (TI) update information periodically, it may not be current at the time you conduct experiments set forth in the book. You understand and agree that you remain responsible for using your independent analysis, evaluation and judgment in conducting experiments contemplated by this book. In addition to the terms below, your use of this book is subject to TI’s Terms of Use located at <http://www.ti.com/corp/docs/legal/termsfuse.shtml> which are incorporated herein by this reference.

THE MATERIAL CONTAINED IN THIS BOOK (THE “CONTENT”) IS PROVIDED “AS IS”. TI MAKES NO WARRANTIES OR REPRESENTATIONS WITH REGARD TO THIS CONTENT, OR USE OF THIS CONTENT, WHETHER EXPRESS, IMPLIED, OR STATUTORY, INCLUDING ACCURACY OR COMPLETENESS. TI DISCLAIMS ANY WARRANTY OF TITLE AND ANY IMPLIED WARRANTIES OF MERCHANTABILITY, FITNESS FOR A PARTICULAR PURPOSE, QUIET ENJOYMENT, QUIET POSSESSION, AND NON-INFRINGEMENT OF ANY THIRD PARTY INTELLECTUAL PROPERTY RIGHTS WITH REGARD TO THE CONTENT OR THE USE OF THE CONTENT. TI SHALL NOT BE LIABLE FOR ANY ACTUAL, SPECIAL, INCIDENTAL, CONSEQUENTIAL OR INDIRECT DAMAGES, HOWEVER CAUSED, ON ANY THEORY OF LIABILITY AND WHETHER OR NOT TI HAS BEEN ADVISED OF THE POSSIBILITY OF SUCH DAMAGES, ARISING IN ANY WAY OUT OF THE CONTENT OR USE OF THE CONTENT.

Certain books may contain experiments which contemplate the use of materials obtained from third parties and/or other materials that may be linked at www.ti.com. IN ALL SUCH INSTANCES, TI OFFERS NO WARRANTIES (EITHER EXPRESS OR IMPLIED), INDEMNIFICATION, OR SUPPORT OF ANY KIND WITH RESPECT TO THIRD PARTY MATERIALS AND, TO THE EXTENT PERMITTED BY LAW, ALL DISCLAIMERS OF WARRANTIES AND LIMITATIONS OF LIABILITY WITHIN THIS NOTICE WILL APPLY TO THE THIRD PARTY MATERIALS, AS WELL.

STANDARD TERMS AND CONDITIONS FOR EVALUATION MODULES

1. *Delivery: TI delivers TI evaluation boards, kits, or modules, including any accompanying demonstration software, components, or documentation (collectively, an “EVM” or “EVMs”) to the User (“User”) in accordance with the terms and conditions set forth herein. Acceptance of the EVM is expressly subject to the following terms and conditions.*
 - 1.1 EVMs are intended solely for product or software developers for use in a research and development setting to facilitate feasibility evaluation, experimentation, or scientific analysis of TI semiconductor products. EVMs have no direct function and are not finished products. EVMs shall not be directly or indirectly assembled as a part or subassembly in any finished product. For clarification, any software or software tools provided with the EVM (“Software”) shall not be subject to the terms and conditions set forth herein but rather shall be subject to the applicable terms and conditions that accompany such Software
 - 1.2 EVMs are not intended for consumer or household use. EVMs may not be sold, sublicensed, leased, rented, loaned, assigned, or otherwise distributed for commercial purposes by Users, in whole or in part, or used in any finished product or production system.
2. *Limited Warranty and Related Remedies/Disclaimers:*
 - 2.1 These terms and conditions do not apply to Software. The warranty, if any, for Software is covered in the applicable Software License Agreement.
 - 2.2 TI warrants that the TI EVM will conform to TI’s published specifications for ninety (90) days after the date TI delivers such EVM to User. Notwithstanding the foregoing, TI shall not be liable for any defects that are caused by neglect, misuse or mistreatment by an entity other than TI, including improper installation or testing, or for any EVMs that have been altered or modified in any way by an entity other than TI. Moreover, TI shall not be liable for any defects that result from User’s design, specifications or instructions for such EVMs. Testing and other quality control techniques are used to the extent TI deems necessary or as mandated by government requirements. TI does not test all parameters of each EVM.
 - 2.3 If any EVM fails to conform to the warranty set forth above, TI’s sole liability shall be at its option to repair or replace such EVM, or credit User’s account for such EVM. TI’s liability under this warranty shall be limited to EVMs that are returned during the warranty period to the address designated by TI and that are determined by TI not to conform to such warranty. If TI elects to repair or replace such EVM, TI shall have a reasonable time to repair such EVM or provide replacements. Repaired EVMs shall be warranted for the remainder of the original warranty period. Replaced EVMs shall be warranted for a new full ninety (90) day warranty period.
3. *Regulatory Notices:*
 - 3.1 United States
 - 3.1.1 *Notice applicable to EVMs not FCC-Approved:*

This kit is designed to allow product developers to evaluate electronic components, circuitry, or software associated with the kit to determine whether to incorporate such items in a finished product and software developers to write software applications for use with the end product. This kit is not a finished product and when assembled may not be resold or otherwise marketed unless all required FCC equipment authorizations are first obtained. Operation is subject to the condition that this product not cause harmful interference to licensed radio stations and that this product accept harmful interference. Unless the assembled kit is designed to operate under part 15, part 18 or part 95 of this chapter, the operator of the kit must operate under the authority of an FCC license holder or must secure an experimental authorization under part 5 of this chapter.
 - 3.1.2 *For EVMs annotated as FCC – FEDERAL COMMUNICATIONS COMMISSION Part 15 Compliant:*

CAUTION

This device complies with part 15 of the FCC Rules. Operation is subject to the following two conditions: (1) This device may not cause harmful interference, and (2) this device must accept any interference received, including interference that may cause undesired operation.

Changes or modifications not expressly approved by the party responsible for compliance could void the user’s authority to operate the equipment.

FCC Interference Statement for Class A EVM devices

NOTE: This equipment has been tested and found to comply with the limits for a Class A digital device, pursuant to part 15 of the FCC Rules. These limits are designed to provide reasonable protection against harmful interference when the equipment is operated in a commercial environment. This equipment generates, uses, and can radiate radio frequency energy and, if not installed and used in accordance with the instruction manual, may cause harmful interference to radio communications. Operation of this equipment in a residential area is likely to cause harmful interference in which case the user will be required to correct the interference at his own expense.

FCC Interference Statement for Class B EVM devices

NOTE: This equipment has been tested and found to comply with the limits for a Class B digital device, pursuant to part 15 of the FCC Rules. These limits are designed to provide reasonable protection against harmful interference in a residential installation. This equipment generates, uses and can radiate radio frequency energy and, if not installed and used in accordance with the instructions, may cause harmful interference to radio communications. However, there is no guarantee that interference will not occur in a particular installation. If this equipment does cause harmful interference to radio or television reception, which can be determined by turning the equipment off and on, the user is encouraged to try to correct the interference by one or more of the following measures:

- *Reorient or relocate the receiving antenna.*
- *Increase the separation between the equipment and receiver.*
- *Connect the equipment into an outlet on a circuit different from that to which the receiver is connected.*
- *Consult the dealer or an experienced radio/TV technician for help.*

3.2 Canada

3.2.1 For EVMs issued with an Industry Canada Certificate of Conformance to RSS-210

Concerning EVMs Including Radio Transmitters:

This device complies with Industry Canada license-exempt RSS standard(s). Operation is subject to the following two conditions: (1) this device may not cause interference, and (2) this device must accept any interference, including interference that may cause undesired operation of the device.

Concernant les EVMs avec appareils radio:

Le présent appareil est conforme aux CNR d'Industrie Canada applicables aux appareils radio exempts de licence. L'exploitation est autorisée aux deux conditions suivantes: (1) l'appareil ne doit pas produire de brouillage, et (2) l'utilisateur de l'appareil doit accepter tout brouillage radioélectrique subi, même si le brouillage est susceptible d'en compromettre le fonctionnement.

Concerning EVMs Including Detachable Antennas:

Under Industry Canada regulations, this radio transmitter may only operate using an antenna of a type and maximum (or lesser) gain approved for the transmitter by Industry Canada. To reduce potential radio interference to other users, the antenna type and its gain should be so chosen that the equivalent isotropically radiated power (e.i.r.p.) is not more than that necessary for successful communication. This radio transmitter has been approved by Industry Canada to operate with the antenna types listed in the user guide with the maximum permissible gain and required antenna impedance for each antenna type indicated. Antenna types not included in this list, having a gain greater than the maximum gain indicated for that type, are strictly prohibited for use with this device.

Concernant les EVMs avec antennes détachables

Conformément à la réglementation d'Industrie Canada, le présent émetteur radio peut fonctionner avec une antenne d'un type et d'un gain maximal (ou inférieur) approuvé pour l'émetteur par Industrie Canada. Dans le but de réduire les risques de brouillage radioélectrique à l'intention des autres utilisateurs, il faut choisir le type d'antenne et son gain de sorte que la puissance isotrope rayonnée équivalente (p.i.r.e.) ne dépasse pas l'intensité nécessaire à l'établissement d'une communication satisfaisante. Le présent émetteur radio a été approuvé par Industrie Canada pour fonctionner avec les types d'antenne énumérés dans le manuel d'usage et ayant un gain admissible maximal et l'impédance requise pour chaque type d'antenne. Les types d'antenne non inclus dans cette liste, ou dont le gain est supérieur au gain maximal indiqué, sont strictement interdits pour l'exploitation de l'émetteur.

3.3 Japan

3.3.1 Notice for EVMs delivered in Japan: Please see http://www.tij.co.jp/lstds/ti_ja/general/eStore/notice_01.page 日本国内に輸入される評価用キット、ボードについては、次のところをご覧ください。 http://www.tij.co.jp/lstds/ti_ja/general/eStore/notice_01.page

3.3.2 Notice for Users of EVMs Considered "Radio Frequency Products" in Japan: EVMs entering Japan may not be certified by TI as conforming to Technical Regulations of Radio Law of Japan. If User uses EVMs in Japan, not certified to Technical Regulations of Radio Law of Japan, User is required by Radio Law of

Japan to follow the instructions below with respect to EVMs:

1. Use EVMs in a shielded room or any other test facility as defined in the notification #173 issued by Ministry of Internal Affairs and Communications on March 28, 2006, based on Sub-section 1.1 of Article 6 of the Ministry's Rule for Enforcement of Radio Law of Japan,
2. Use EVMs only after User obtains the license of Test Radio Station as provided in Radio Law of Japan with respect to EVMs, or
3. Use of EVMs only after User obtains the Technical Regulations Conformity Certification as provided in Radio Law of Japan with respect to EVMs. Also, do not transfer EVMs, unless User gives the same notice above to the transferee. Please note that if User does not follow the instructions above, User will be subject to penalties of Radio Law of Japan.

【無線電波を送信する製品の開発キットをお使いになる際の注意事項】 開発キットの中には技術基準適合証明を受けていないものがあります。技術適合証明を受けていないもののご使用に際しては、電波法遵守のため、以下のいずれかの措置を取っていただく必要がありますのでご注意ください。

1. 電波法施行規則第6条第1項第1号に基づく平成18年3月28日総務省告示第173号で定められた電波暗室等の試験設備でご使用いただく。
2. 実験局の免許を取得後ご使用いただく。
3. 技術基準適合証明を取得後ご使用いただく。なお、本製品は、上記の「ご使用にあたっての注意」を譲渡先、移転先に通知しない限り、譲渡、移転できないものとしします。上記を遵守頂けない場合は、電波法の罰則が適用される可能性があることをご留意ください。日本テキサス・インスツルメンツ株式会社

東京都新宿区西新宿 6 丁目 2 4 番 1 号
西新宿三井ビル

3.3.3 Notice for EVMs for Power Line Communication: Please see http://www.tij.co.jp/lstds/ti_ja/general/eStore/notice_02.page

電力線搬送波通信についての開発キットをお使いになる際の注意事項については、次のところをご覧ください。 http://www.tij.co.jp/lstds/ti_ja/general/eStore/notice_02.page

4. *EVM Use Restrictions and Warnings:*

- 4.1 EVMS ARE NOT FOR USE IN FUNCTIONAL SAFETY AND/OR SAFETY CRITICAL EVALUATIONS, INCLUDING BUT NOT LIMITED TO EVALUATIONS OF LIFE SUPPORT APPLICATIONS.
- 4.2 User must read and apply the user guide and other available documentation provided by TI regarding the EVM prior to handling or using the EVM, including without limitation any warning or restriction notices. The notices contain important safety information related to, for example, temperatures and voltages.
- 4.3 Safety-Related Warnings and Restrictions:
 - 4.3.1 User shall operate the EVM within TI's recommended specifications and environmental considerations stated in the user guide, other available documentation provided by TI, and any other applicable requirements and employ reasonable and customary safeguards. Exceeding the specified performance ratings and specifications (including but not limited to input and output voltage, current, power, and environmental ranges) for the EVM may cause personal injury or death, or property damage. If there are questions concerning performance ratings and specifications, User should contact a TI field representative prior to connecting interface electronics including input power and intended loads. Any loads applied outside of the specified output range may also result in unintended and/or inaccurate operation and/or possible permanent damage to the EVM and/or interface electronics. Please consult the EVM user guide prior to connecting any load to the EVM output. If there is uncertainty as to the load specification, please contact a TI field representative. During normal operation, even with the inputs and outputs kept within the specified allowable ranges, some circuit components may have elevated case temperatures. These components include but are not limited to linear regulators, switching transistors, pass transistors, current sense resistors, and heat sinks, which can be identified using the information in the associated documentation. When working with the EVM, please be aware that the EVM may become very warm.
 - 4.3.2 EVMs are intended solely for use by technically qualified, professional electronics experts who are familiar with the dangers and application risks associated with handling electrical mechanical components, systems, and subsystems. User assumes all responsibility and liability for proper and safe handling and use of the EVM by User or its employees, affiliates, contractors or designees. User assumes all responsibility and liability to ensure that any interfaces (electronic and/or mechanical) between the EVM and any human body are designed with suitable isolation and means to safely limit accessible leakage currents to minimize the risk of electrical shock hazard. User assumes all responsibility and liability for any improper or unsafe handling or use of the EVM by User or its employees, affiliates, contractors or designees.
- 4.4 User assumes all responsibility and liability to determine whether the EVM is subject to any applicable international, federal, state, or local laws and regulations related to User's handling and use of the EVM and, if applicable, User assumes all responsibility and liability for compliance in all respects with such laws and regulations. User assumes all responsibility and liability for proper disposal and recycling of the EVM consistent with all applicable international, federal, state, and local requirements.

5. *Accuracy of Information:* To the extent TI provides information on the availability and function of EVMs, TI attempts to be as accurate as possible. However, TI does not warrant the accuracy of EVM descriptions, EVM availability or other information on its websites as accurate, complete, reliable, current, or error-free.

6. **Disclaimers:**

- 6.1 EXCEPT AS SET FORTH ABOVE, EVMS AND ANY WRITTEN DESIGN MATERIALS PROVIDED WITH THE EVM (AND THE DESIGN OF THE EVM ITSELF) ARE PROVIDED "AS IS" AND "WITH ALL FAULTS." TI DISCLAIMS ALL OTHER WARRANTIES, EXPRESS OR IMPLIED, REGARDING SUCH ITEMS, INCLUDING BUT NOT LIMITED TO ANY IMPLIED WARRANTIES OF MERCHANTABILITY OR FITNESS FOR A PARTICULAR PURPOSE OR NON-INFRINGEMENT OF ANY THIRD PARTY PATENTS, COPYRIGHTS, TRADE SECRETS OR OTHER INTELLECTUAL PROPERTY RIGHTS.
- 6.2 EXCEPT FOR THE LIMITED RIGHT TO USE THE EVM SET FORTH HEREIN, NOTHING IN THESE TERMS AND CONDITIONS SHALL BE CONSTRUED AS GRANTING OR CONFERRING ANY RIGHTS BY LICENSE, PATENT, OR ANY OTHER INDUSTRIAL OR INTELLECTUAL PROPERTY RIGHT OF TI, ITS SUPPLIERS/LICENSORS OR ANY OTHER THIRD PARTY, TO USE THE EVM IN ANY FINISHED END-USER OR READY-TO-USE FINAL PRODUCT, OR FOR ANY INVENTION, DISCOVERY OR IMPROVEMENT MADE, CONCEIVED OR ACQUIRED PRIOR TO OR AFTER DELIVERY OF THE EVM.

7. **USER'S INDEMNITY OBLIGATIONS AND REPRESENTATIONS.** USER WILL DEFEND, INDEMNIFY AND HOLD TI, ITS LICENSORS AND THEIR REPRESENTATIVES HARMLESS FROM AND AGAINST ANY AND ALL CLAIMS, DAMAGES, LOSSES, EXPENSES, COSTS AND LIABILITIES (COLLECTIVELY, "CLAIMS") ARISING OUT OF OR IN CONNECTION WITH ANY HANDLING OR USE OF THE EVM THAT IS NOT IN ACCORDANCE WITH THESE TERMS AND CONDITIONS. THIS OBLIGATION SHALL APPLY WHETHER CLAIMS ARISE UNDER STATUTE, REGULATION, OR THE LAW OF TORT, CONTRACT OR ANY OTHER LEGAL THEORY, AND EVEN IF THE EVM FAILS TO PERFORM AS DESCRIBED OR EXPECTED.

8. **Limitations on Damages and Liability:**

- 8.1 General Limitations. IN NO EVENT SHALL TI BE LIABLE FOR ANY SPECIAL, COLLATERAL, INDIRECT, PUNITIVE, INCIDENTAL, CONSEQUENTIAL, OR EXEMPLARY DAMAGES IN CONNECTION WITH OR ARISING OUT OF THESE TERMS AND CONDITIONS OR THE USE OF THE EVMS PROVIDED HEREUNDER, REGARDLESS OF WHETHER TI HAS BEEN ADVISED OF THE POSSIBILITY OF SUCH DAMAGES. EXCLUDED DAMAGES INCLUDE, BUT ARE NOT LIMITED TO, COST OF REMOVAL OR REINSTALLATION, ANCILLARY COSTS TO THE PROCUREMENT OF SUBSTITUTE GOODS OR SERVICES, RETESTING, OUTSIDE COMPUTER TIME, LABOR COSTS, LOSS OF GOODWILL, LOSS OF PROFITS, LOSS OF SAVINGS, LOSS OF USE, LOSS OF DATA, OR BUSINESS INTERRUPTION. NO CLAIM, SUIT OR ACTION SHALL BE BROUGHT AGAINST TI MORE THAN ONE YEAR AFTER THE RELATED CAUSE OF ACTION HAS OCCURRED.
- 8.2 Specific Limitations. IN NO EVENT SHALL TI'S AGGREGATE LIABILITY FROM ANY WARRANTY OR OTHER OBLIGATION ARISING OUT OF OR IN CONNECTION WITH THESE TERMS AND CONDITIONS, OR ANY USE OF ANY TI EVM PROVIDED HEREUNDER, EXCEED THE TOTAL AMOUNT PAID TO TI FOR THE PARTICULAR UNITS SOLD UNDER THESE TERMS AND CONDITIONS WITH RESPECT TO WHICH LOSSES OR DAMAGES ARE CLAIMED. THE EXISTENCE OF MORE THAN ONE CLAIM AGAINST THE PARTICULAR UNITS SOLD TO USER UNDER THESE TERMS AND CONDITIONS SHALL NOT ENLARGE OR EXTEND THIS LIMIT.

9. **Return Policy.** Except as otherwise provided, TI does not offer any refunds, returns, or exchanges. Furthermore, no return of EVM(s) will be accepted if the package has been opened and no return of the EVM(s) will be accepted if they are damaged or otherwise not in a resalable condition. If User feels it has been incorrectly charged for the EVM(s) it ordered or that delivery violates the applicable order, User should contact TI. All refunds will be made in full within thirty (30) working days from the return of the components(s), excluding any postage or packaging costs.

10. **Governing Law:** These terms and conditions shall be governed by and interpreted in accordance with the laws of the State of Texas, without reference to conflict-of-laws principles. User agrees that non-exclusive jurisdiction for any dispute arising out of or relating to these terms and conditions lies within courts located in the State of Texas and consents to venue in Dallas County, Texas. Notwithstanding the foregoing, any judgment may be enforced in any United States or foreign court, and TI may seek injunctive relief in any United States or foreign court.

Mailing Address: Texas Instruments, Post Office Box 655303, Dallas, Texas 75265
Copyright © 2016, Texas Instruments Incorporated



TI-PMLK

TI Power Management Lab Kit
Boost Experiment Book



IMPORTANT NOTICE FOR TI DESIGN INFORMATION AND RESOURCES

Texas Instruments Incorporated ("TI") technical, application or other design advice, services or information, including, but not limited to, reference designs and materials relating to evaluation modules, (collectively, "TI Resources") are intended to assist designers who are developing applications that incorporate TI products; by downloading, accessing or using any particular TI Resource in any way, you (individually or, if you are acting on behalf of a company, your company) agree to use it solely for this purpose and subject to the terms of this Notice.

TI's provision of TI Resources does not expand or otherwise alter TI's applicable published warranties or warranty disclaimers for TI products, and no additional obligations or liabilities arise from TI providing such TI Resources. TI reserves the right to make corrections, enhancements, improvements and other changes to its TI Resources.

You understand and agree that you remain responsible for using your independent analysis, evaluation and judgment in designing your applications and that you have full and exclusive responsibility to assure the safety of your applications and compliance of your applications (and of all TI products used in or for your applications) with all applicable regulations, laws and other applicable requirements. You represent that, with respect to your applications, you have all the necessary expertise to create and implement safeguards that (1) anticipate dangerous consequences of failures, (2) monitor failures and their consequences, and (3) lessen the likelihood of failures that might cause harm and take appropriate actions. You agree that prior to using or distributing any applications that include TI products, you will thoroughly test such applications and the functionality of such TI products as used in such applications. TI has not conducted any testing other than that specifically described in the published documentation for a particular TI Resource.

You are authorized to use, copy and modify any individual TI Resource only in connection with the development of applications that include the TI product(s) identified in such TI Resource. NO OTHER LICENSE, EXPRESS OR IMPLIED, BY ESTOPPEL OR OTHERWISE TO ANY OTHER TI INTELLECTUAL PROPERTY RIGHT, AND NO LICENSE TO ANY TECHNOLOGY OR INTELLECTUAL PROPERTY RIGHT OF TI OR ANY THIRD PARTY IS GRANTED HEREIN, including but not limited to any patent right, copyright, mask work right, or other intellectual property right relating to any combination, machine, or process in which TI products or services are used. Information regarding or referencing third-party products or services does not constitute a license to use such products or services, or a warranty or endorsement thereof. Use of TI Resources may require a license from a third party under the patents or other intellectual property of the third party, or a license from TI under the patents or other intellectual property of TI.

TI RESOURCES ARE PROVIDED "AS IS" AND WITH ALL FAULTS. TI DISCLAIMS ALL OTHER WARRANTIES OR REPRESENTATIONS, EXPRESS OR IMPLIED, REGARDING TI RESOURCES OR USE THEREOF, INCLUDING BUT NOT LIMITED TO ACCURACY OR COMPLETENESS, TITLE, ANY EPIDEMIC FAILURE WARRANTY AND ANY IMPLIED WARRANTIES OF MERCHANTABILITY, FITNESS FOR A PARTICULAR PURPOSE, AND NON-INFRINGEMENT OF ANY THIRD PARTY INTELLECTUAL PROPERTY RIGHTS.

TI SHALL NOT BE LIABLE FOR AND SHALL NOT DEFEND OR INDEMNIFY YOU AGAINST ANY CLAIM, INCLUDING BUT NOT LIMITED TO ANY INFRINGEMENT CLAIM THAT RELATES TO OR IS BASED ON ANY COMBINATION OF PRODUCTS EVEN IF DESCRIBED IN TI RESOURCES OR OTHERWISE. IN NO EVENT SHALL TI BE LIABLE FOR ANY ACTUAL, DIRECT, SPECIAL, COLLATERAL, INDIRECT, PUNITIVE, INCIDENTAL, CONSEQUENTIAL OR EXEMPLARY DAMAGES IN CONNECTION WITH OR ARISING OUT OF TI RESOURCES OR USE THEREOF, AND REGARDLESS OF WHETHER TI HAS BEEN ADVISED OF THE POSSIBILITY OF SUCH DAMAGES.

You agree to fully indemnify TI and its representatives against any damages, costs, losses, and/or liabilities arising out of your non-compliance with the terms and provisions of this Notice.

This Notice applies to TI Resources. Additional terms apply to the use and purchase of certain types of materials, TI products and services. These include; without limitation, TI's standard terms for semiconductor products (<http://www.ti.com/sc/docs/stdterms.htm>), [evaluation modules](#), and [samples](http://www.ti.com/sc/docs/sampterm.htm) (<http://www.ti.com/sc/docs/sampterm.htm>).

Mailing Address: Texas Instruments, Post Office Box 655303, Dallas, Texas 75265
Copyright © 2018, Texas Instruments Incorporated