

PRODUCT NUMBER
89882-XXX(Z)LF

- ROHS COMPATIBLE, SEE NOTE 5.
- OPTIONAL LETTER
- H: HIGH TEMPERATURE PRODUCT.
- NUMBER OF POSITIONS: 02 TO 65.
- PLATING CODE
- 3= 0.76µm GOLD ON CONTACT AREA.
- 2µm MIN MATTE TIN ON TAIL.
- 4= 2µm MIN MATTE TIN FULL PLATED
- 1.27µm Ni MIN UNDERPLATING

NOTES:

- 1 - HOUSING MAT'L: THERMOPLASTIC GLASS FILLED FLAME RETARDANT PER UL 94 V-0
LOW TEMPERATURE: COLOR BLUE
HIGH TEMPERATURE: COLOR GREY.
- 2 - TERMINAL MATERIAL: PHOSPHOR BRONZE.
- 3 - 2 UP TO 4 POSITIONS PRODUCT PACKED IN PLASTIC BOX.
- 5 UP TO 65 POSITIONS PRODUCT PACKED IN TUBE.
- 4 - TO DETERMINE DIMENSIONS:
N = NUMBER OF POSITIONS
EXAMPLE: 8 POS: (N×2.54)-0.08=20.24 mm.
- 5 - ROHS COMPATIBLE PRODUCT SPECIFICATIONS

a - PLATING:

- "LF" MEANS THE PRODUCT IS LEAD-FREE, 2µm MINIMUM MATTE TIN OVER 1.27µm MINIMUM NICKEL UNDERPLATE.

b - MANUFACTURING PROCESS COMPATIBILITY

- THE HOUSING WILL WITHSTAND EXPOSURE TO 260°C ±5°C SOLDER BATH TEMPERATURE FOR 5 SECONDS IN A WAVE SOLDER APPLICATION WITH A 1.6mm MIN THICK CIRCUIT BOARD.

c - LABELING:

- MEETS PACKAGING SPECS AS PER GS-14-920
- LEGAL STATEMENT: SEE GS-47-0004

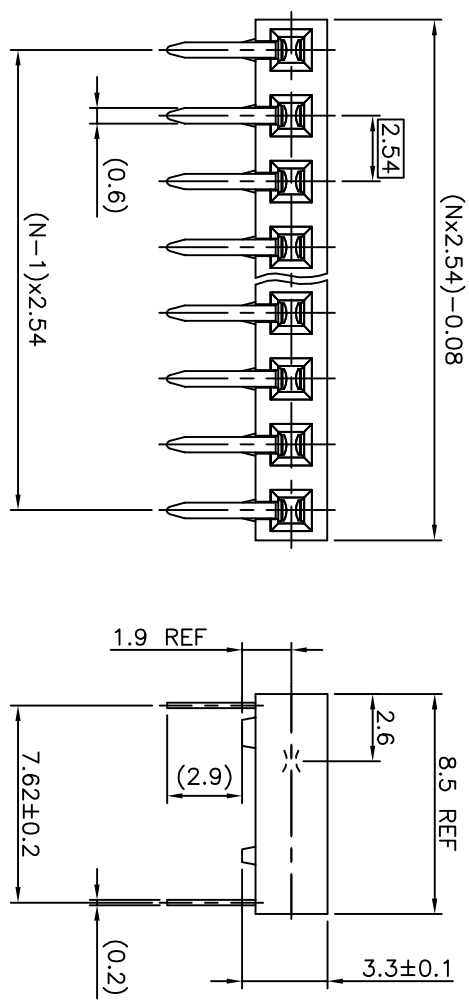

mat'l. code	SEE NOTES	surface	tolerance	projection	product family			
ltr	ecn no	dr	date	ISO 1302	ISO 406	ISO 1101	ISO 1101	title
K	B-19123	LMU	14.10.21	tolerances unless otherwise specified	±0.3	mm	scale 5:1	BtB RECEPT. HORIZ SR TMT
E	F10110	GC0	01.01.16	angles	linear	mm	scale 5:1	
F	04-0145	DLE	04.02.25	dr	D	LEGRAND	04.08.29	dwg no
G	F04-0347	DLE	04.09.28	engr	P	NIZZI	04.09.28	89882
H	F06-0204	DLE	06.06.21	th	D	LEGRAND	04.09.28	sheet 1 of 2
J	F06-0330	DLE	06.12.04	appd	P	NZ	04.09.28	A3
sheet	revision	K	B					Drwng
index	sheet	1	2					

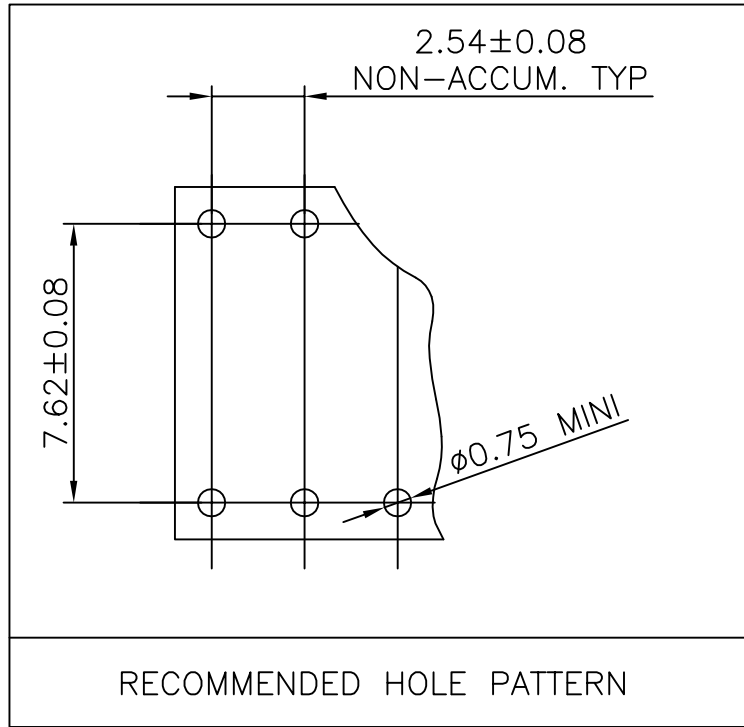

FCIconnect.com

Copyright FCI

mat'l. code SEE SHEET 1				surface ISO 1302 ✓		tolerance ISO 406 ISO 1101		projection 		product family DUBOX					
ltr	ecn no	dr	date	tolerances unless otherwise specified				mm ←→		title BtB RECEPT. HORIZ SR TMT					
A	F04-0347	DLE	04.09.28	angles linear	±0.3				scale 5:1		dwg no 89882		sheet 2 of 2 size A4		
B	F06-0204	DLE	06.06.21		±2'				FCI						type CUSTOMER
				dr	D LEGRAND	04.09.28									
				enr	P NIZZI	04.09.28									
				chr	D LE	04.09.28									
				appd	P NZ	04.09.28									
sheet index		revision sheet													