

PART NUMBER CODING

C D N-M71RC

INSULATOR / CONTACT MATERIAL

PR= PBT / BRASS
 OPERATING TEMPERATURE: -40° C TO +105° C.
 PROCESSING TEMP: WAVE/MANUAL SOLDERING ONLY.

NR= NYLON 6T / BRASS

OPERATING TEMPERATURE: -40° C TO +105° C.
 PROCESSING TEMP: WAVE/MANUAL SOLDERING ONLY.

LR= LCP / BRASS

OPERATING TEMPERATURE: -40° C TO +125° C.
 PROCESSING TEMP: 230°C MAX FOR 60 SECS
 (260°C MAX FOR 10 SECS)

TERMINATION TYPE

NUMBER OF POSITIONS
 (CONTACTS PER ROW, 002 THRU 040)

PLATING

(ALL PLATINGS HAVE .000030"~.000050" MIN NICKEL UNDERPLATE)
 CONTACT SURFACE TERMINATION
 B = .000010" GOLD .000100" PURE TIN, MATTE
 C = .000030" GOLD .000100" PURE TIN, MATTE
 E = TIN OVERALL
 P = GOLD FLASH OVERALL

REVISIONS				
REV.	ECO. NO	DESCRIPTION	DATE	BY
D	2668	ADD 'LCP' MATERIAL AND REMOVE 'NYLON 9T'	09/06/2012	LH
E	2828	UPDATE PROCESSING TEMPERATURE FOR NYLON 6T MATERIAL, UPDATE LCP OPERATING TEMP TO -40°C TO +125°C (WAS -40°C TO +105°C)	04/09/2015	LH

CODE	HEAD DIM		TAIL DIM	
	INCH	MM	INCH	MM
BA	0.230	5.84	0.120	3.05
BB	0.230	5.84	0.220	5.59
BC	0.230	5.84	0.320	8.13
BD	0.230	5.84	0.420	10.67
BE	0.230	5.84	0.520	13.21
BH	0.230	5.84	0.820	20.83
BI	0.230	5.84	0.920	23.37
BJ	0.230	5.84	1.020	25.91
GA	0.318	8.08	0.120	3.05
GB	0.318	8.08	0.220	5.59
GE	0.318	8.08	0.620	15.75
GF	0.318	8.08	0.820	20.83

PART NUMBER	A		B	
	INCH	MM	INCH	MM
__C002D__N-M71RC	0.100	2.54	0.200	5.08
__C003D__N-M71RC	0.200	5.08	0.300	7.62
__C004D__N-M71RC	0.300	7.62	0.400	10.16
__C005D__N-M71RC	0.400	10.16	0.500	12.70
__C006D__N-M71RC	0.500	12.70	0.600	15.24
__C007D__N-M71RC	0.600	15.24	0.700	17.78
__C008D__N-M71RC	0.700	17.78	0.800	20.32
__C009D__N-M71RC	0.800	20.32	0.900	22.86
__C010D__N-M71RC	0.900	22.86	1.000	25.40
__C011D__N-M71RC	1.000	25.40	1.100	27.94
__C012D__N-M71RC	1.100	27.94	1.200	30.48
__C013D__N-M71RC	1.200	30.48	1.300	33.02
__C014D__N-M71RC	1.300	33.02	1.400	35.56
__C015D__N-M71RC	1.400	35.56	1.500	38.10
__C016D__N-M71RC	1.500	38.10	1.600	40.64
__C017D__N-M71RC	1.600	40.64	1.700	43.18
__C018D__N-M71RC	1.700	43.18	1.800	45.72
__C019D__N-M71RC	1.800	45.72	1.900	48.26
__C020D__N-M71RC	1.900	48.26	2.000	50.80
__C021D__N-M71RC	2.000	50.80	2.100	53.34
__C022D__N-M71RC	2.100	53.34	2.200	55.88
__C023D__N-M71RC	2.200	55.88	2.300	58.42
__C024D__N-M71RC	2.300	58.42	2.400	60.96
__C025D__N-M71RC	2.400	60.96	2.500	63.50
__C026D__N-M71RC	2.500	63.50	2.600	66.04
__C027D__N-M71RC	2.600	66.04	2.700	68.58
__C028D__N-M71RC	2.700	68.58	2.800	71.12
__C029D__N-M71RC	2.800	71.12	2.900	73.66
__C030D__N-M71RC	2.900	73.66	3.000	76.20
__C031D__N-M71RC	3.000	76.20	3.100	78.74
__C032D__N-M71RC	3.100	78.74	3.200	81.28
__C033D__N-M71RC	3.200	81.28	3.300	83.82
__C034D__N-M71RC	3.300	83.82	3.400	86.36
__C035D__N-M71RC	3.400	86.36	3.500	88.90
__C036D__N-M71RC	3.500	88.90	3.600	91.44
__C037D__N-M71RC	3.600	91.44	3.700	93.98
__C038D__N-M71RC	3.700	93.98	3.800	96.52
__C039D__N-M71RC	3.800	96.52	3.900	99.06
__C040D__N-M71RC	3.900	99.06	4.000	101.60

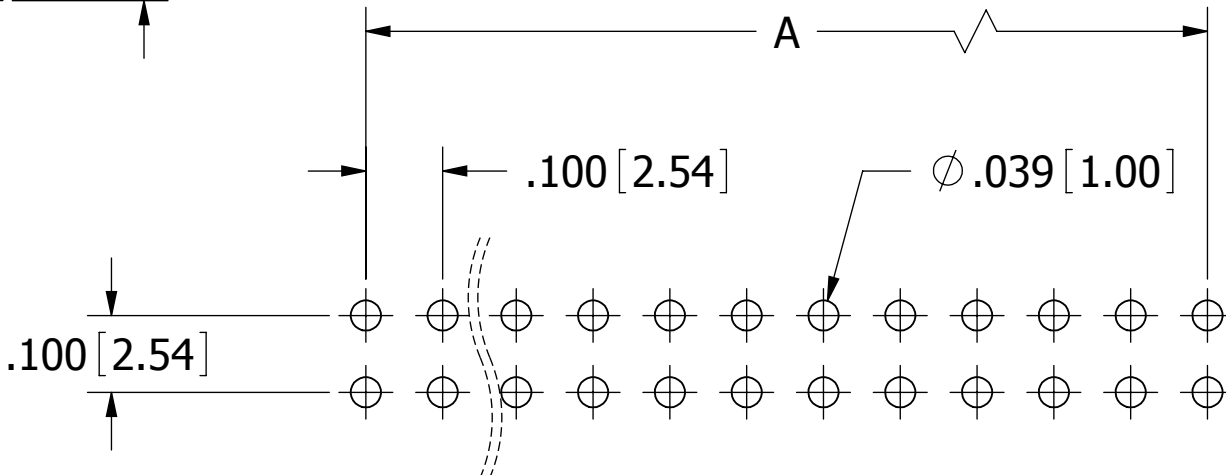
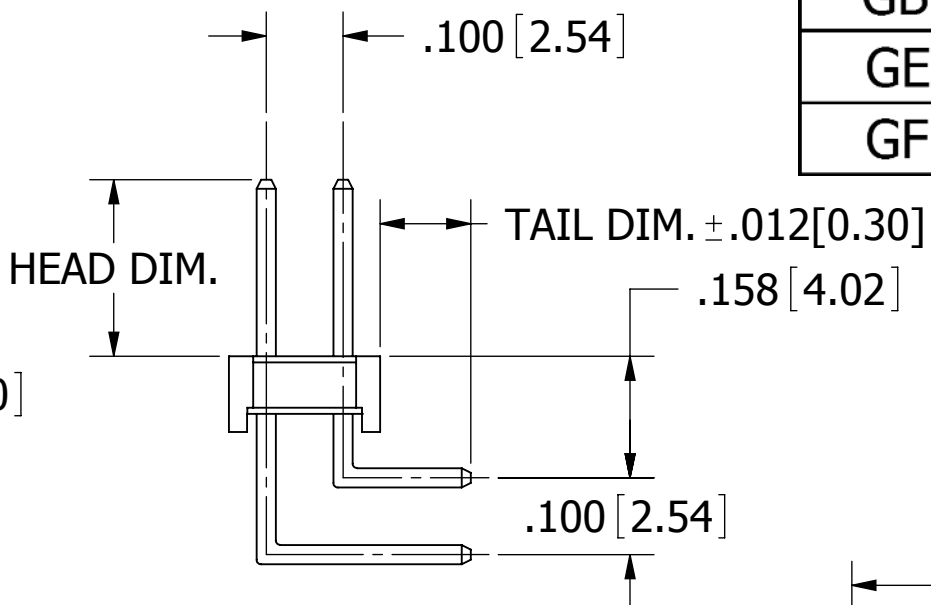
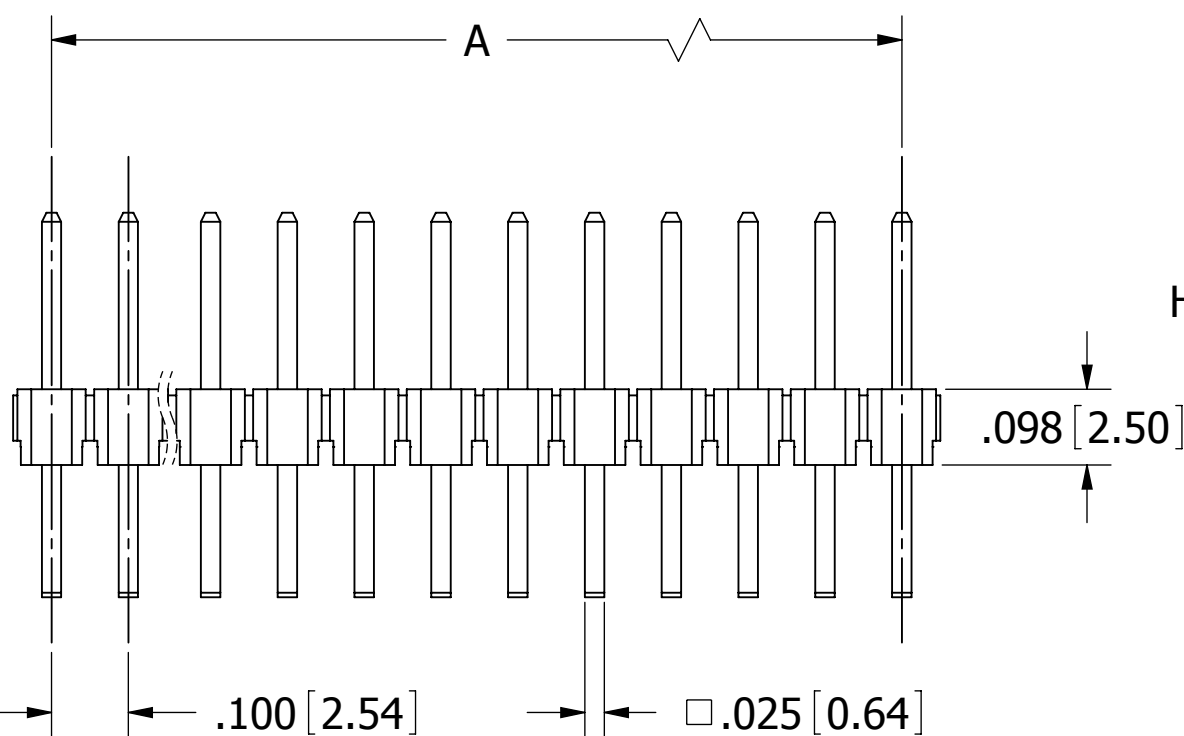
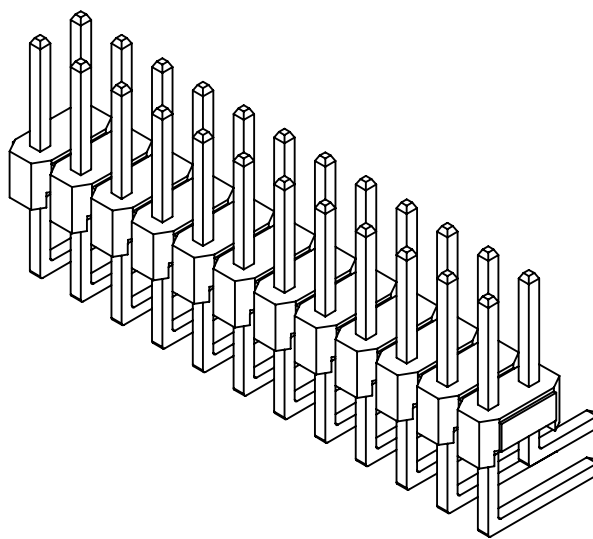
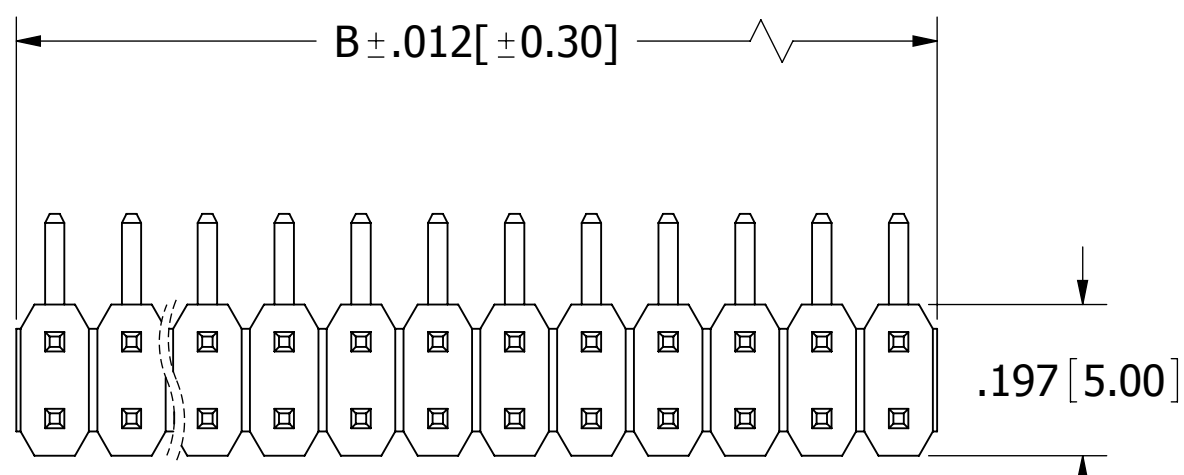

RECOMMENDED PCB LAYOUT

- NOTES:**
1. INSULATOR MATERIAL: SEE PART NUMBER CODING, UL 94V-0, BLACK.
 2. CONTACT MATERIAL: SEE PART NUMBER CODING.
 3. CONTACT PLATING: SEE PART NUMBER CODING.
 4. CURRENT RATING: 3 AMPS.
 5. INSULATOR RESISTANCE: 5000 MEGOHMS MIN.
 6. CONTACT RESISTANCE: 20 MILLIOHMS MAX.
 7. DIELECTRIC WITHSTANDING: 1000 VAC.
 8. OPERATING TEMPERATURE: SEE PART NUMBER CODING.



UNLESS OTHERWISE SPECIFIED: DIMENSIONS ARE IN INCHES [MM]		DRAWN	DATE	NAME	
TOLERANCES:			03/21/2011	LH	
ANGULAR:		THE INFORMATION HEREIN CONTAINS PROPRIETARY INFORMATION OF SULLINS ELECTRONICS AND IS NOT TO BE REPRODUCED, USED OR DISCLOSED TO OTHERS FOR ANY PURPOSE EXCEPT AS SPECIFICALLY AUTHORIZED IN WRITING BY AN OFFICER OF SULLINS ELECTRONICS.			TITLE
DECIMALS					HEADER .100"[2.54mm]PITCH, 2 ROWS, RA
.XX=± .01 [3]					PART NUMBER
.XXX=± .008 [20]					__R__C__-D__N-M71RC
.XXXX=± .0040 [100]		SIZE	CAGE CODE	DWG. NO.	REV
		C	54453	11639	E
		SCALE: 4:1		SHEET 1 OF 1	