

MULTILAYER CERAMIC ANTENNA (LINEAR POLARIZATION MODE)
1.88 GHz ~2.1 GHz
Product Specification¹ (Preliminary)

QUICK REFERENCE DATA

Dimension	8.8* 6.8 * 0.9 mm
Working Frequency	1.88~2.1 GHz
Gain	2 dBi Max
VSWR	2 max
Polarization	Linear
Azimuth	Omni-directional
Impedance	50Ω
Operating Temperature	-55~125 °C
Termination	Ni/Sn (Environmentally-Friendly Leadless)
Resistance to soldering heat	260°C, 10 sec.



Special Environmental Concerns- Green Products Design: The foil making process is using environmentally friendly aqueous solvent technology. Termination is lead free and packing materials can be re-cycled

¹ All the technical data and information contained herein are subject to change without prior notice

R&D	Print date 02/06/03		Preliminary use only			
	Multilayer Ceramic Antenna for 1.88GHz~2.1GHz	4311 112 00188	Nov. 20, 01			
			Dec. 13, 01 Jan. 7, 02			
Cliff Wang, Ph.D.		2002-01-07	Page 1/9	sheet 190-1		A4
spec.doc	Phycomp Taiwan Ltd.					

APPLICATION

Suggested Layout

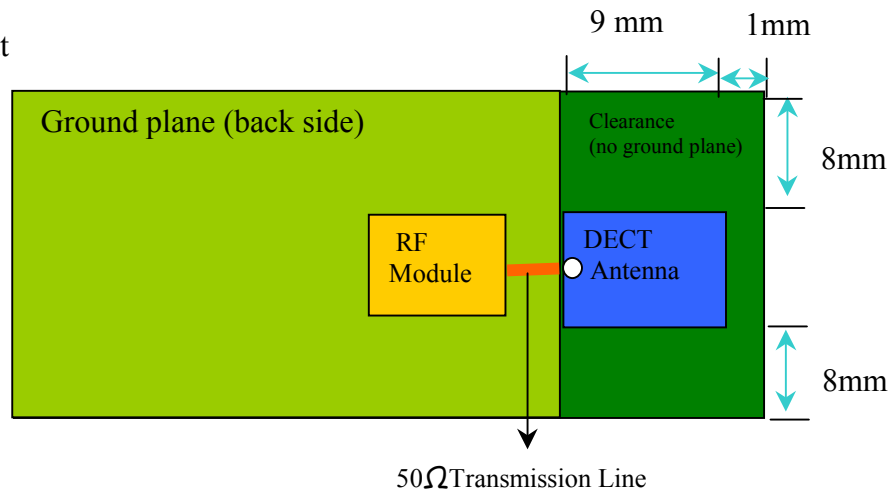

DIMENSIONAL DATA

Figure	Dimension	Port	
	L	8.8±0.2mm	-
	W	6.8±0.2mm	-
	T	0.9±0.2mm	-
	F	4.3±0.2mm	Feed termination
	C	0.5±0.3mm	-
	S1	0.5±0.3mm	Solder termination
	S2	1.3±0.2mm	Solder termination
		4.3±0.2mm	

R&D	Print date 02/06/03	Preliminary use only			
	Multilayer Ceramic Antenna for 1.88GHz~2.1GHz	4311 112 00188	Nov. 20, 01		
			Dec. 13, 01 Jan. 7, 02		
Cliff Wang, Ph.D.	2002-01-07	Page 2/9	sheet 190-2		A4
spec.doc	Phycomp Taiwan Ltd.				

SOLDER LAND PATTERN

Figure	Dimensions (mm)	Remark																						
	<table border="1"> <tr> <td>L</td> <td>10.00 ± 0.10</td> </tr> <tr> <td>W</td> <td>7.00 ± 0.10</td> </tr> <tr> <td>F</td> <td>1.40 ± 0.10</td> </tr> <tr> <td>F*</td> <td>1.40 ± 0.10</td> </tr> <tr> <td>C</td> <td>0.90 ± 0.10</td> </tr> <tr> <td>S1</td> <td>1.40 ± 0.10</td> </tr> <tr> <td>S2</td> <td>1.40 ± 0.10</td> </tr> </table>	L	10.00 ± 0.10	W	7.00 ± 0.10	F	1.40 ± 0.10	F*	1.40 ± 0.10	C	0.90 ± 0.10	S1	1.40 ± 0.10	S2	1.40 ± 0.10	<table border="1"> <tr> <td>F</td> <td>Feed Pad</td> </tr> <tr> <td>F*</td> <td>Feed Pad (Optional)</td> </tr> <tr> <td>S1</td> <td>NC Mount Pad Only</td> </tr> <tr> <td>S2</td> <td>NC Mount Pad Only</td> </tr> </table>	F	Feed Pad	F*	Feed Pad (Optional)	S1	NC Mount Pad Only	S2	NC Mount Pad Only
L	10.00 ± 0.10																							
W	7.00 ± 0.10																							
F	1.40 ± 0.10																							
F*	1.40 ± 0.10																							
C	0.90 ± 0.10																							
S1	1.40 ± 0.10																							
S2	1.40 ± 0.10																							
F	Feed Pad																							
F*	Feed Pad (Optional)																							
S1	NC Mount Pad Only																							
S2	NC Mount Pad Only																							

Radiation Pattern

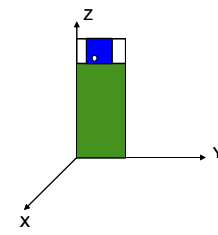
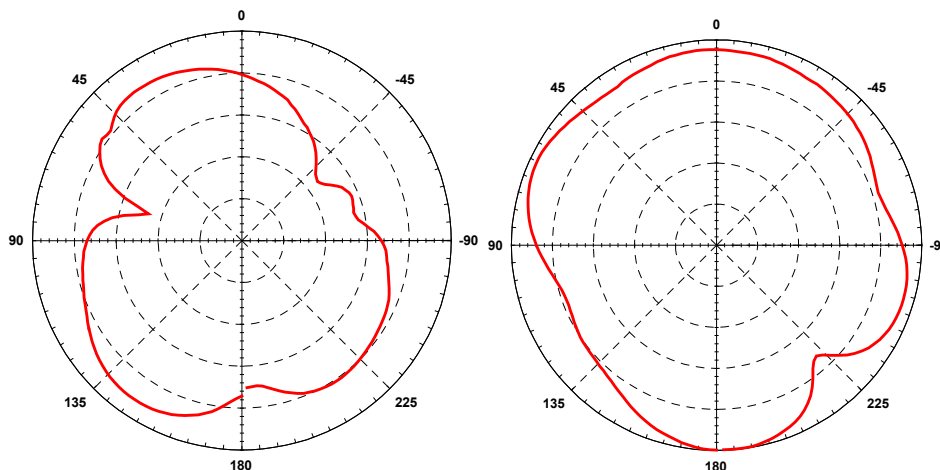

E Plane (ZY Plane) & H Plane (XY Plane)

R&D	Print date 02/06/03	Preliminary use only			
	Multilayer Ceramic Antenna for 1.88GHz~2.1GHz	4311 112 00188		Nov. 20, 01	
				Dec. 13, 01 Jan. 7, 02	
Cliff Wang, Ph.D.	2002-01-07	Page 3/9	sheet 190-3		A4
spec.doc	Phycomp Taiwan Ltd.				

RELIABILITY DATA (Reference to IEC Specification)

IEC 384-10/ CECC 32 100 CLAUSE	IEC 6006868-2 TEST METHOD	TEST	PROCEDURE	REQUIREMENTS
4.4		Mounting	The antenna can be mounted on printed-circuit boards or ceramic substrates by applying wave soldering, reflow soldering (including vapour phase soldering) or conductive adhesive	No visible damage
4.5		Visual inspection and dimension check	Any applicable method using $\times 10$ magnification	In accordance with specification (no chip off 3 mm)
4.8		Adhesion	A force of 5 N applied for 10 s to the line joining the terminations and in a plane parallel to the substrate	No visible damage
4.9		Bond strength of plating on end face	Mounted in accordance with CECC 32 100, paragraph 4.4	No visible damage
			Conditions: bending 0.5 mm at a rate of 1mm/s, radius jig. 340 mm, 1 mm warp on FR4 board of 90 mm length	No visible damage
4.10	Tb	Resistance to soldering heat	260 ± 5 °C for 10 ± 0.5 s in a static solder bath	The terminations shall be well tinned after recovery and Central Freq. Change $\pm 6\%$

R&D	Print date 02/06/03		Preliminary use only			
	Multilayer Ceramic Antenna for 1.88GHz~2.1GHz		4311 112 00188		Nov. 20, 01	
					Dec. 13, 01	
					Jan. 7, 02	
Cliff Wang, Ph.D.		2002-01-07	Page 4/9	sheet 190-4		A4
spec.doc	Phycomp Taiwan Ltd.					

IEC 384-10/ CECC 32 100 CLAUSE	IEC 6006868-2 TEST METHOD	TEST	PROCEDURE	REQUIREMENTS
		Resistance to leaching	260 ± 5 °C for 30 ± 1 s in a static solder bath	Using visual enlargement of × 10, dissolution of the termination shall not exceed 10%
4.11	Ta	Solderability	Zero hour test, and test after storage (20 to 24 months) in original atmosphere; un-mounted chips completely immersed for 2 ± 0.5 s in 235 ± 5°C.	The termination must be well tinned, at least 75% is well tinned at termination
4.12	Na	Rapid change of temperature	-55 °C (30 minutes) to +125 °C (30 minutes); 100 cycles	No visible damage Central Freq. Change ± 6%
4.14	Ca	Damp heat	500 ± 12 hours at 60 °C; 90 to 95 % RH	No visible damage 2 hours recovery Central Freq. Change ± 6%
4.15		Endurance	500 ± 12 hours at 125 °C;	No visible damage 2 hours recovery Central Freq. Change ± 6%

R&D	Print date 02/06/03		Preliminary use only			
	Multilayer Ceramic Antenna for 1.88GHz~2.1GHz		4311 112 00188		Nov. 20, 01	
					Dec. 13, 01 Jan. 7, 02	
Cliff Wang, Ph.D.		2002-01-07	Page 5/9	sheet 190-5		A4
spec.doc	Phycomp Taiwan Ltd.					

ORDERING INFORMATION: 12NC Ordering Code

The DECT antennas may be ordered by using the 12 NC ordering code. These code numbers can be determined by the following rules:

4311 1 12 00 188
 F C MS T A

F. Family Code

43 = Antenna

M. Materials Code

1 = High Frequency Material

S. Size Code

12 = 8.8*6.8 * 0.9 mm

T. Tolerance

00 = 100 M Hz Band Width

A. Working Frequency

188 = 1.88 GHz~2.1GHz

C. Packing Type Code

11 = 180 mm/ 7" blister (1000pcs)

13 = 330 mm/ 13"blister (4000pcs)

Example: 12NC 4311 112 00188
 Product description: Antenna (43) by 1000 pcs (11) of High Frequency Material (1), Size 8.8*6.8*0.9 mm (12); Tolerance (00) of 100 MHz (VSWR<2) Working Frequency (188) = 1.88G~2.1GHz Hz

ORDERING INFORMATION: Method II- by Clear Text Code

The antennas may be ordered by using the 16-digit clear text ordering code. These code numbers can be determined by the following rules:

AN1880000788681K (Clear Text Code Example)						
AN	1880	00	07	8868	1	K
Product	Central Freq.	Bandwidth	Material	Size	Quantities	Packing
AN= Antenna	1880=1.80GHz ~ 2.1GHz	00= >100MHz	07=K7	8868=8.8*6.8*0.9 mm	1 = 1K	K=7" plastic F =13" plastic B = Bulk

R&D	Print date 02/06/03		Preliminary use only			
	Multilayer Ceramic Antenna for 1.88GHz~2.1GHz		4311 112 00188		Nov. 20, 01	
					Dec. 13, 01 Jan. 7, 02	
Cliff Wang, Ph.D.		2002-01-07	Page 6/9	sheet 190-6		A4
spec.doc	Phycomp Taiwan Ltd.					

Blister Tape Specifications

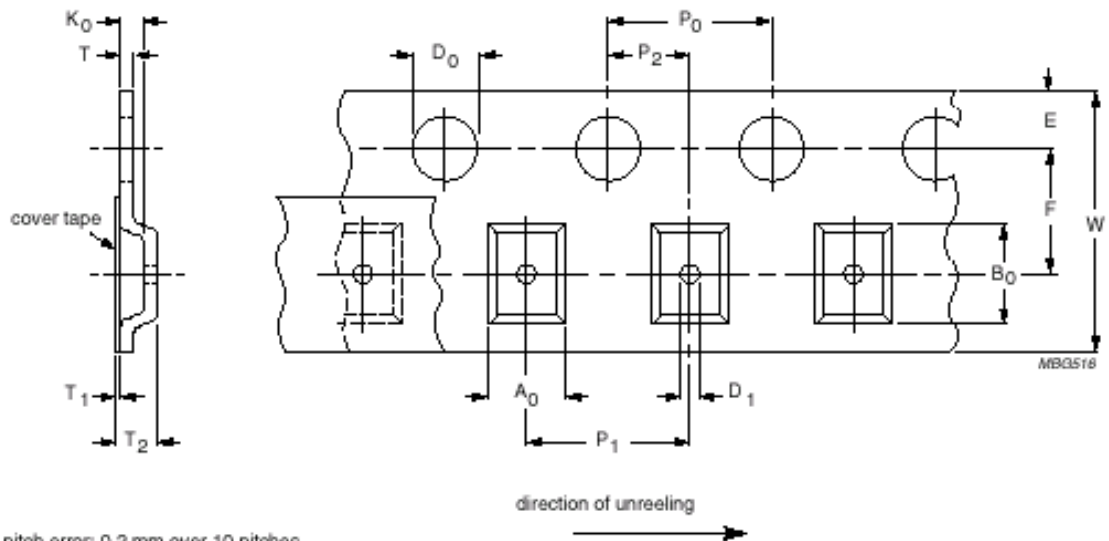

Cumulative pitch error: 0.2 mm over 10 pitches.

Cumulative tolerance over 10 holes: ± 0.2 mm.

K_0 : chosen so that the orientation of the component cannot change.

For dimensions see Table 4.

DIMENSION:

Serial no	Checking note	Index	Spec(mm)
1	Sprocket hole	Do	1.55 \pm 0.10
2	Pocket hole	D1	1.50 \pm 0.10
3	Distance sprocket hole/sprocket hole	Po	4.0 \pm 0.10
4	Distance pocket/pocket	P1	12.0 \pm 0.10
5	Distance sprocket hole/pocket	P2	2.0 \pm 0.10
6	Tape width	W	16.0 \pm 0.30
7	Distance sprocket hole/outside	E	1.75 \pm 0.10
8	Distance sprocket hole/pocket	F	7.50 \pm 0.10
9	Pocket length	Ao	7.45 \pm 0.10
10	Pocket length	Bo	9.30 \pm 0.10
11	Pocket depth	Ko	1.35 \pm 0.10
12	Thickness of tape	T	0.25 \pm 0.10

R&D	Print date 02/06/03	Preliminary use only			
	Multilayer Ceramic Antenna for 1.88GHz~2.1GHz	4311 112 00188	Nov. 20, 01		
			Dec. 13, 01 Jan. 7, 02		
Cliff Wang, Ph.D.	2002-01-07	Page 7/9	sheet 190-7		A4
spec.doc	Phycomp Taiwan Ltd.				

7”(180mm) Reel Specifications

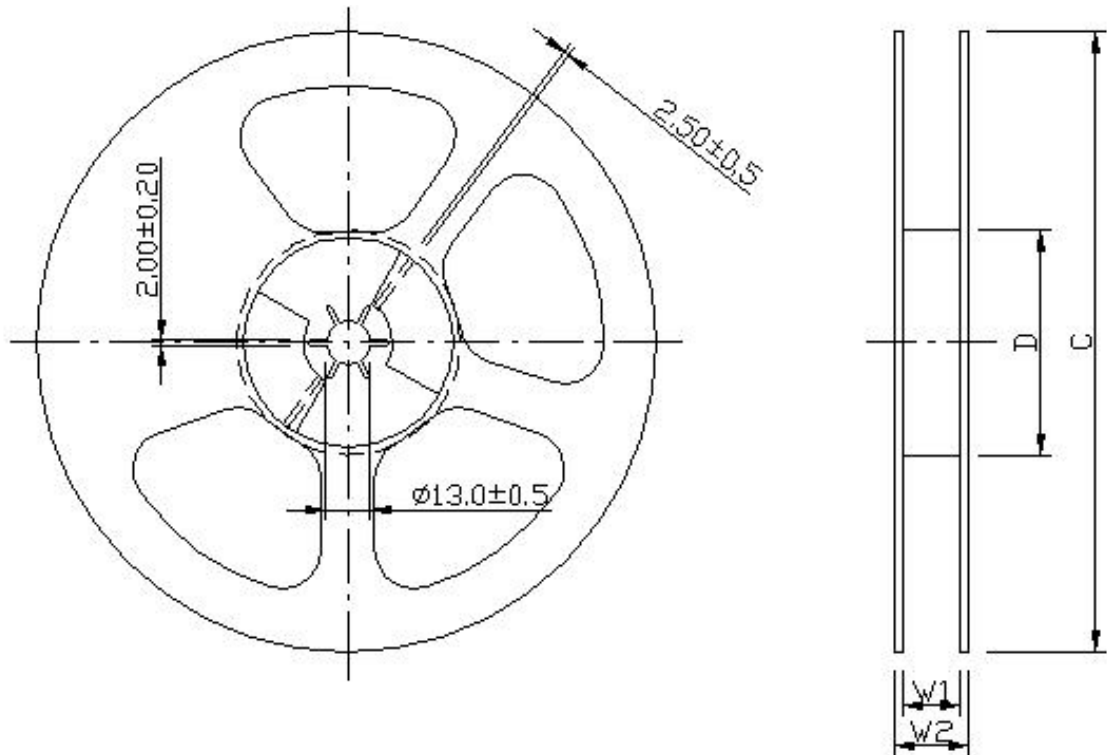

Product size code	Units per Reel	Tape Width (mm)	C (mm)	D (mm)	W ₁ (mm)	W ₂ (mm)
Antenna	1000	16	180.0±1.0	62±0.5	16.0 ⁺¹ ₋₀	20.5±0.2

R&D	Print date 02/06/03		Preliminary use only			
	Multilayer Ceramic Antenna for 1.88GHz~2.1GHz		4311 112 00188		Nov. 20, 01	
					Dec. 13, 01 Jan. 7, 02	
Cliff Wang, Ph.D.		2002-01-07	Page 8/9	sheet 190-8		A4
spec.doc	Phycomp Taiwan Ltd.					

13”(330mm) Reel Specifications

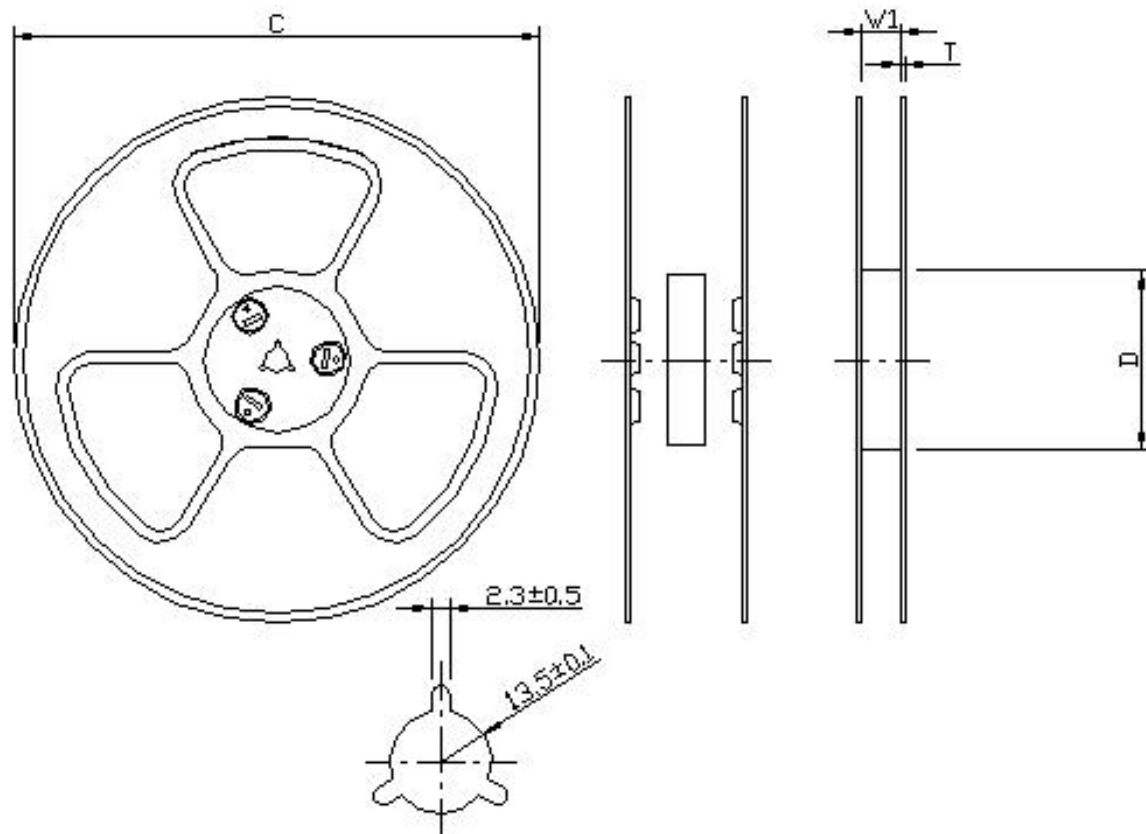

Product size code	Units per Reel	Tape Width (mm)	C (mm)	D (mm)	W ₁ (mm)	T (mm)
Antenna	4000	16	330±0.10	100±0.1	16.5±0.10	2.3±0.1

R&D	Print date 02/06/03		Preliminary use only			
	Multilayer Ceramic Antenna for 1.88GHz~2.1GHz		4311 112 00188		Nov. 20, 01	
					Dec. 13, 01 Jan. 7, 02	
Cliff Wang, Ph.D.		2002-01-07	Page 9/9	sheet 190-9		A4
spec.doc	Phycomp Taiwan Ltd.					