

## NOTES:

### 1.0 Materials

- 1.1 Body, Coupling, and Clamp Nuts: Steel. Corrosion Resistant per ASTM-A582. UNS No. S30300.
- 1.2 Center Conductor: Beryllium Copper per ASTM-B196. UNS C17300.
- 1.3 Solder Ferrule: Brass per ASTM-B16. UNS C36000.
- 1.4 Lock Ring: Beryllium Copper per ASTM-B197. UNS C17200.
- 1.5 Gasket and O-Ring: Silicone Rubber per A-A-59588.
- 1.6 Insulator: PTFE Fluorocarbon per ASTM-D1710.
- 1.7 Dielectric Beads: Polyetherimide Thermoplastic (ULTEM 1000) per ASTM-D5205.

### 2.0 Finishes

- 2.1 Center Contact and Solder Ferrule: Gold Plate per ASTM-B488 50 Microinches Min. thickness over Electrolytic Nickel Plate per ASTM-B689 50 Microinches Min. thickness.
- 2.2 Body, Coupling, and Clamp Nuts: Passivated per SAE-AMS-2700.
- 2.3 Gasket, O-Ring, Lock Ring, and Dielectrics: None.

3.0 Interface: TNCA Plug per MIL-STD-348. Figure 313-3.

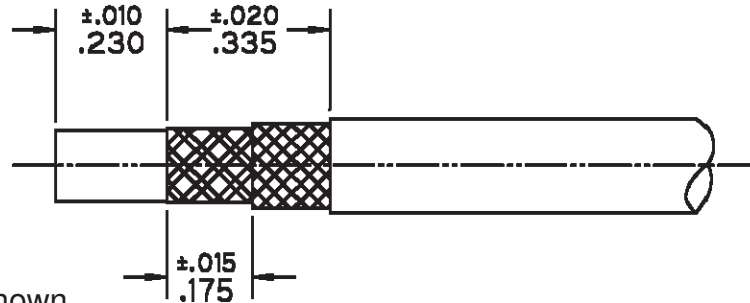

Step 1 1.1 Trim Cable as shown.

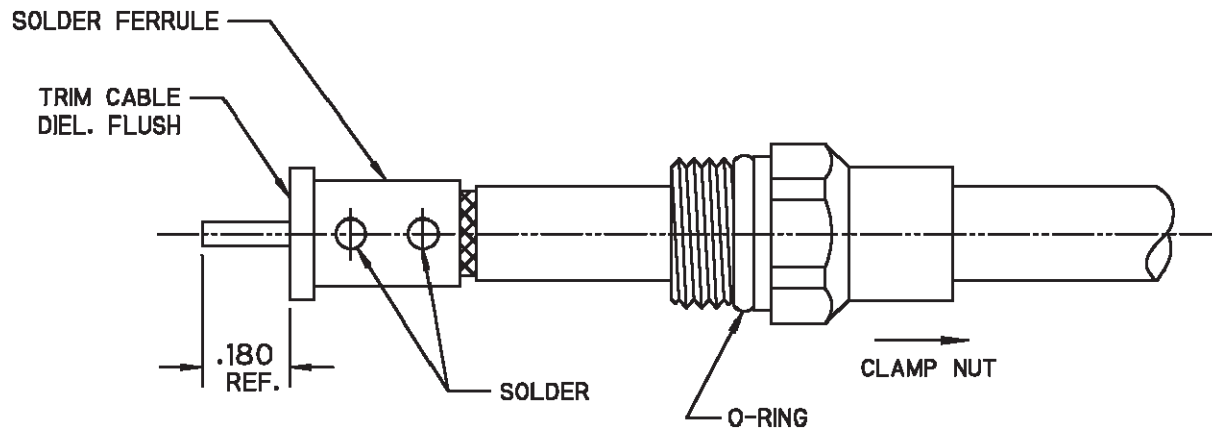

2.1 Slide clamp nut over cable as shown.  
2.2 Insert cable into solder ferrule until forward braid seats then solder both cable braids where shown.  
2.3 Trim cable dielectric flush to solder ferrule.

Step 2

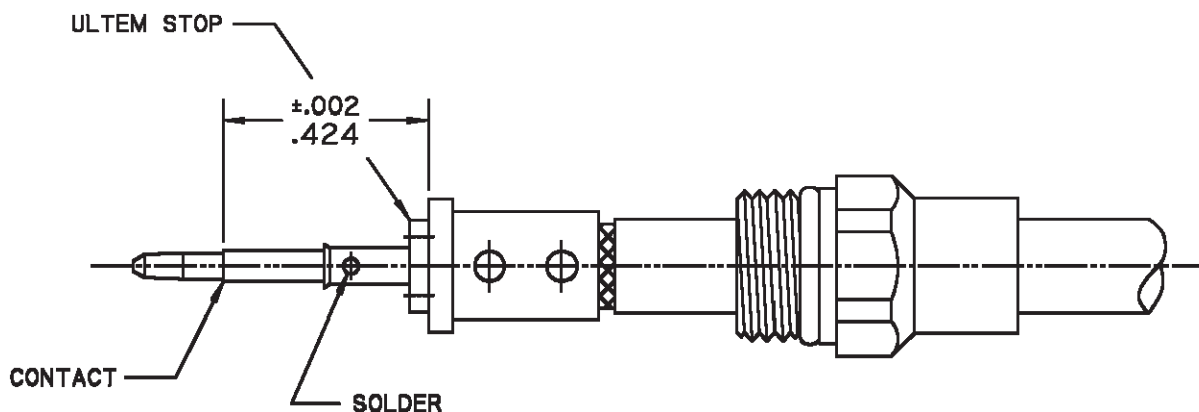

3.1 Slide Ultem dielectric stop over cable center conductor against solder ferrule as shown.  
3.2 Solder contact flush against stop to dimension shown.

Step 3

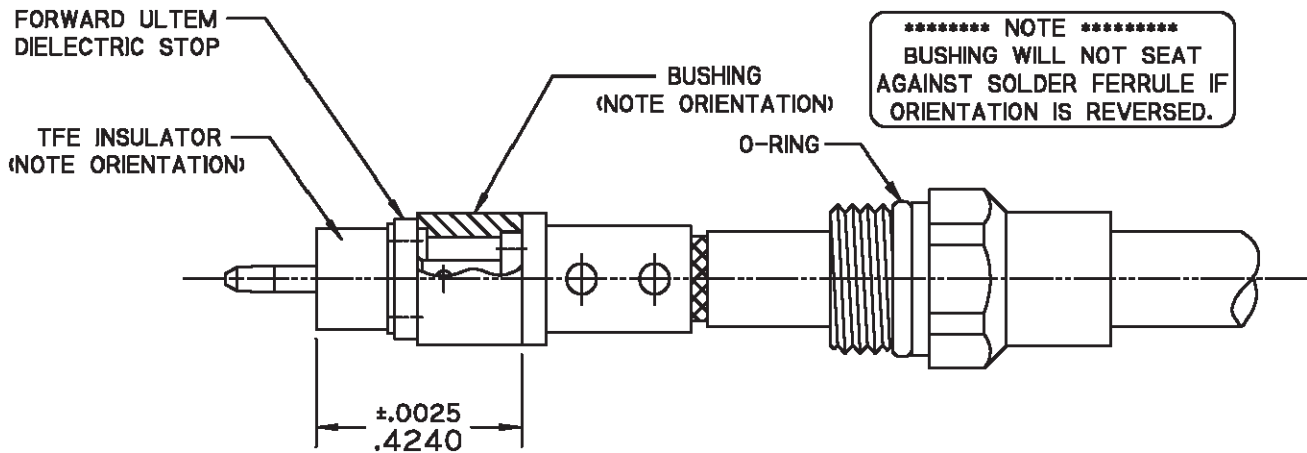

4.1 Slide bushing. Forward Ultem stop and forward teflon insulator over contact as shown. (Note: orient bushing with deeper smaller diameter c'bore toward solder ferrule. Orient forward TFE insulator with shoulder toward stop.)

Step 4

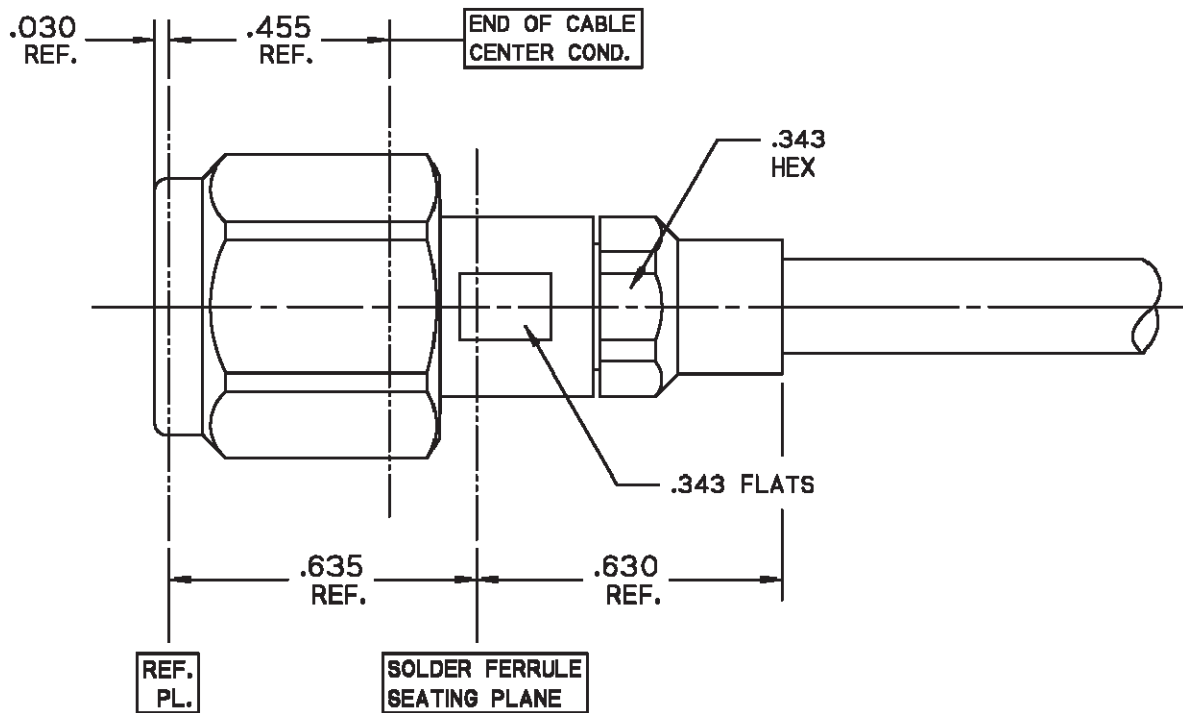

5.1 Insert cable/contact sub-assembly into connector until seated and tighten clamp nut to 35-45 in-lbs.

Step 5

**Product Control:**

Crystek Part Number:	CS-TM-MHA	Release Date:	04-Jan-11
Revision Level:	A	Responsible:	K. Piotrowicz