

LOC		DIST		REVISIONS			
GP	00	REV	DATE	BY	CHK	APPV	
K3	REVISED PER ECO-11-004835	11MAR11	RK	HMR			

- ① RCPT CONNECTOR FULLY LOADED WITH CONTACTS. ALL OTHER PARTS SHIPPED UNASSEMBLED (EACH PART INDIVIDUALLY BULK PACKED).
- ② NUMBER ON CONTACT INDICATES WIRE RANGE.
- ③ SHIELDS: MATERIAL—.020 THICK STEEL, TIN PLATED.
- ④ CONTACTS PLATED .000030 GOLD ON MATING END FOR .100 MIN LENGTH. .000100—.000200 BRIGHT TIN OR BRIGHT TIN-LEAD IN WIRE TERMINATION AREA. .000050 NICKEL UNDERPLATE ON ENTIRE CONTACT.
- ⑤ CONTACTS PLATED WITH GOLD FLASH ON MATING END FOR .100 MIN LENGTH. .000100—.000200 BRIGHT TIN OR BRIGHT TIN-LEAD IN WIRE TERMINATION AREA. .000030 NICKEL UNDERPLATE ON ENTIRE CONTACT.
- ⑥ RAISED CAVITY IDENTIFICATION AND AMP TRADEMARK.
- ⑦ CONTACTS PLATED .000030 GOLD ON MATING END FOR .100 MIN LENGTH. .000100—.000200 MATTE TIN IN WIRE TERMINATION AREA. .000050 MIN NICKEL UNDERPLATE ON ENTIRE CONTACT.
- ⑧ CONTACTS PLATED WITH GOLD FLASH ON MATING END FOR .100 MIN LENGTH. .000100—.000200 MATTE TIN IN WIRE TERMINATION AREA. .000030 MIN NICKEL UNDERPLATE ON ENTIRE CONTACT.

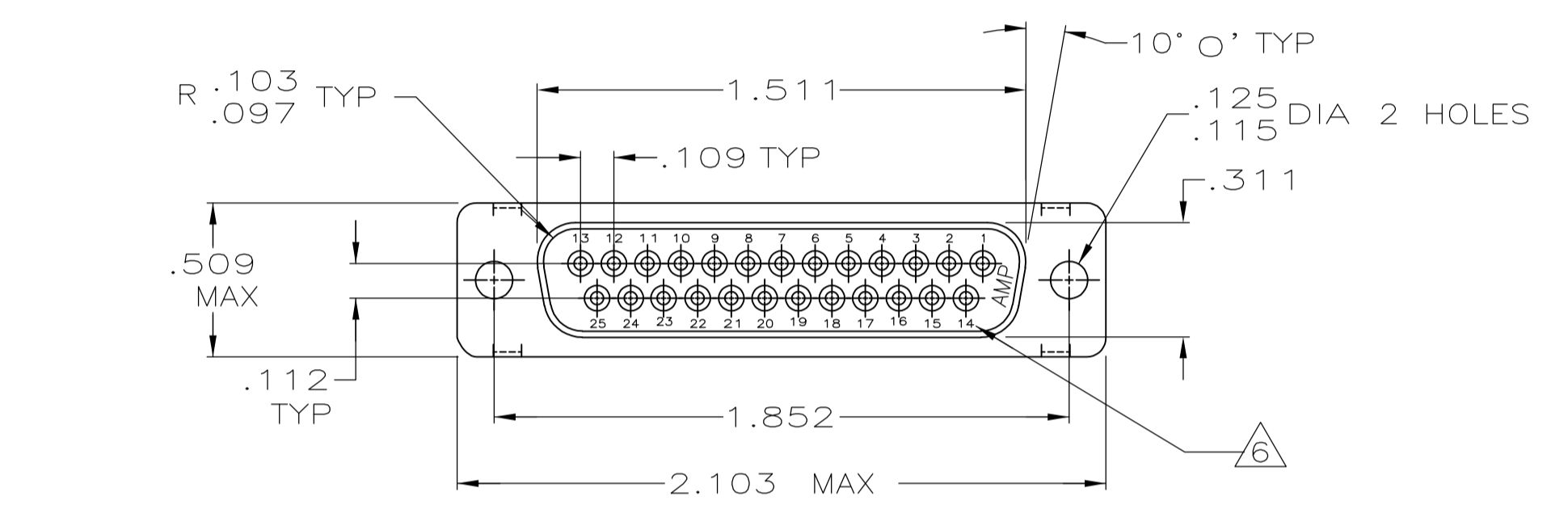

RCPT CONNECTOR
 INSERT: BLACK THERMOPLASTIC,
 94V-0 RATED.
 SHELL: STEEL PER ASTM A109,
 BRIGHT TIN PLATED
 PER MIL-T-10727.

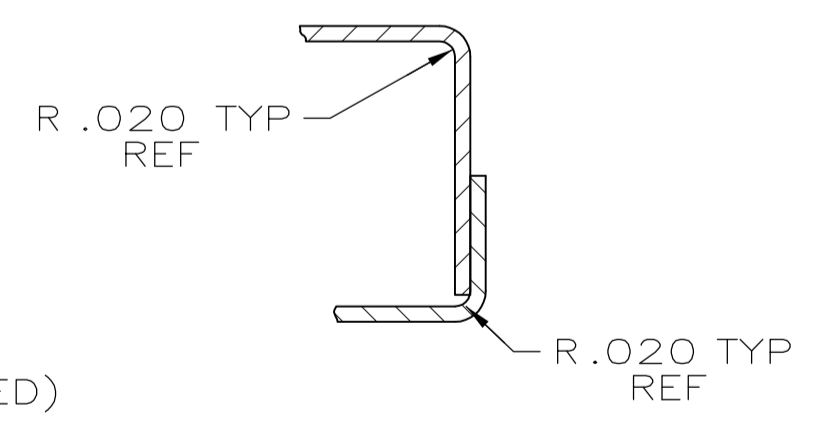
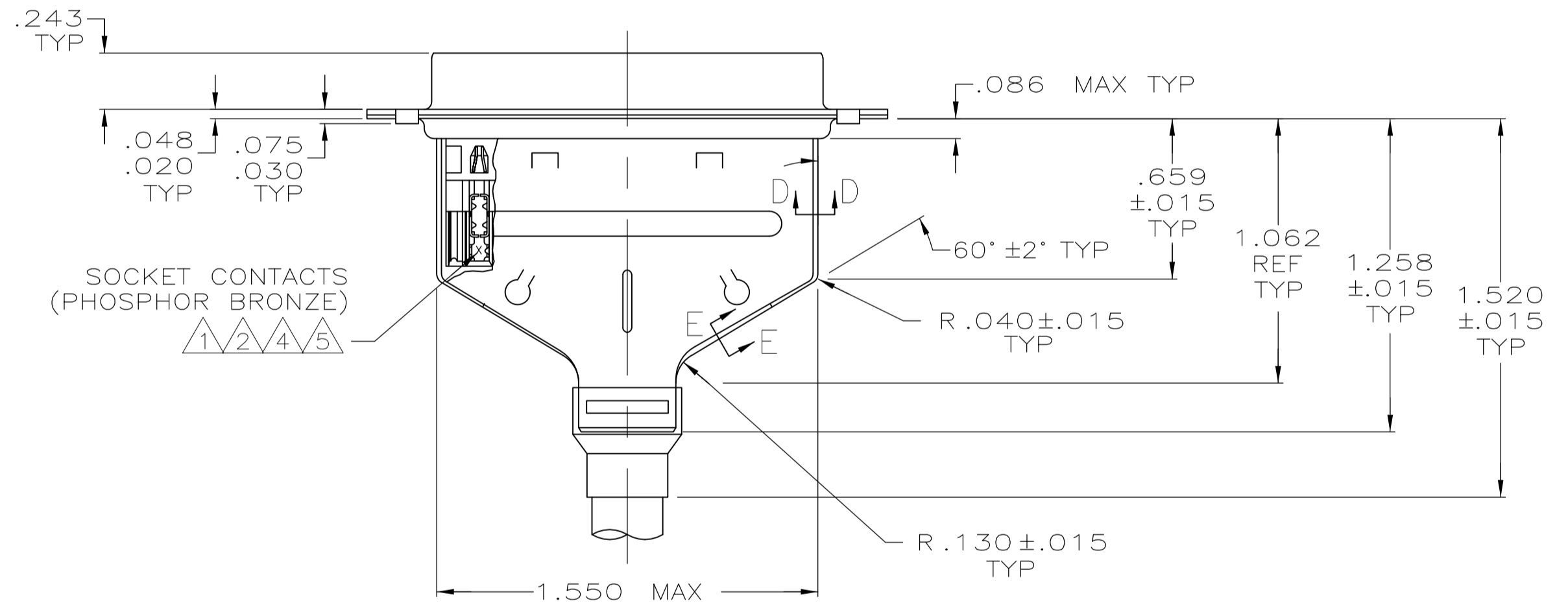
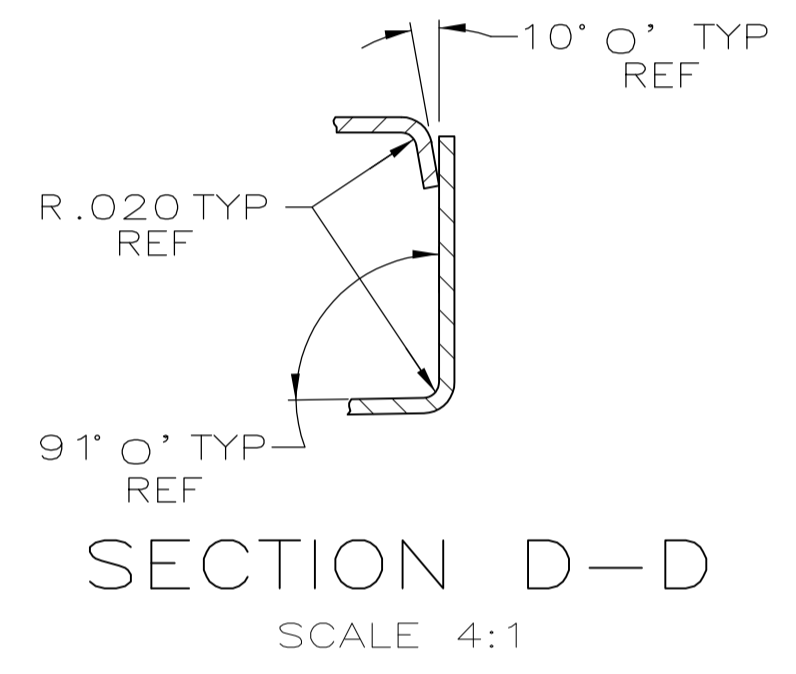

SECTION E-E
 SCALE 4:1

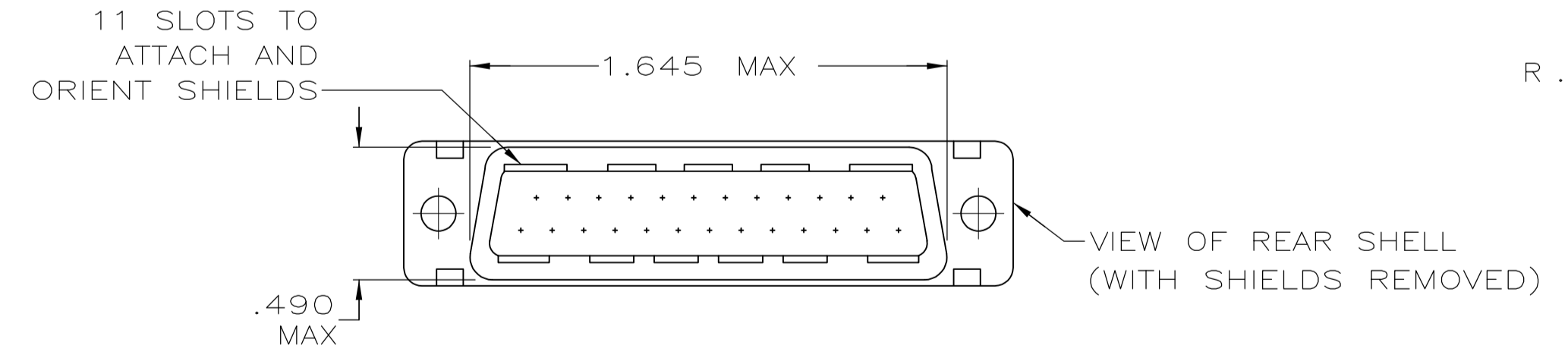

REV	DESCRIPTION	DATE	BY	CHK	APPV
3	#22-26	747548-9			
2	#22-26	747548-8			
1	#26-30	747548-7			
3	#20-22	747548-6			
2	#22-26	747548-5			
1	#26-30	747548-4			
3	#20-22	747548-3			
2	#22-26	747548-2			
1	#26-30	747548-1			
CONTACT FINISH		②	WIRE RANGE	PART NUMBER	

THIS DRAWING IS A CONTROLLED DOCUMENT.

DIMENSIONS: INCHES	TOLERANCES UNLESS OTHERWISE SPECIFIED:	DIN	11-16-04
0 PLC ± -	1 PLC ± -	L. VARELA - DOCKS	11-16-04
2 PLC ± -	3 PLC ± .005	J. GERACE	
4 PLC ± -	ANGLES ± 0° 30'	M. WALMSLEY	11-16-04
FINISH	SEE TABLE	NAME	
SEE CALL OUTS		PRODUCT SPEC	108-40011 & 108-40030
		APPLICATION SPEC	108-40002
		SIZE	A1
		WEIGHT	00779
		CUSTOMER DRAWING	747548

STE TE Connectivity
 KIT, RCPT, SHIELDING HARDWARE, SIZE 3, 25 POSN, HDE-20, AMPLITE

SCALE 2:1 SHEET 1 OF 1 REV K3