



IR Emitter and Detector Product Data Sheet

LTE-C9306

Spec No.: DS50-2007-0010

Effective Date: 04/20/2007

Revision: -

LITE-ON DCC

RELEASE

BNS-OD-FC001/A4

FEATURES

- * MEET ROHS, GREEN PRODUCT.
- * PACKAGE IN 8MM TAPE ON 7" DIAMETER REELS.
- * COMPATIBLE WITH INFRARED AND SOLDER PROCESS.
- * EIA STD PACKAGE.

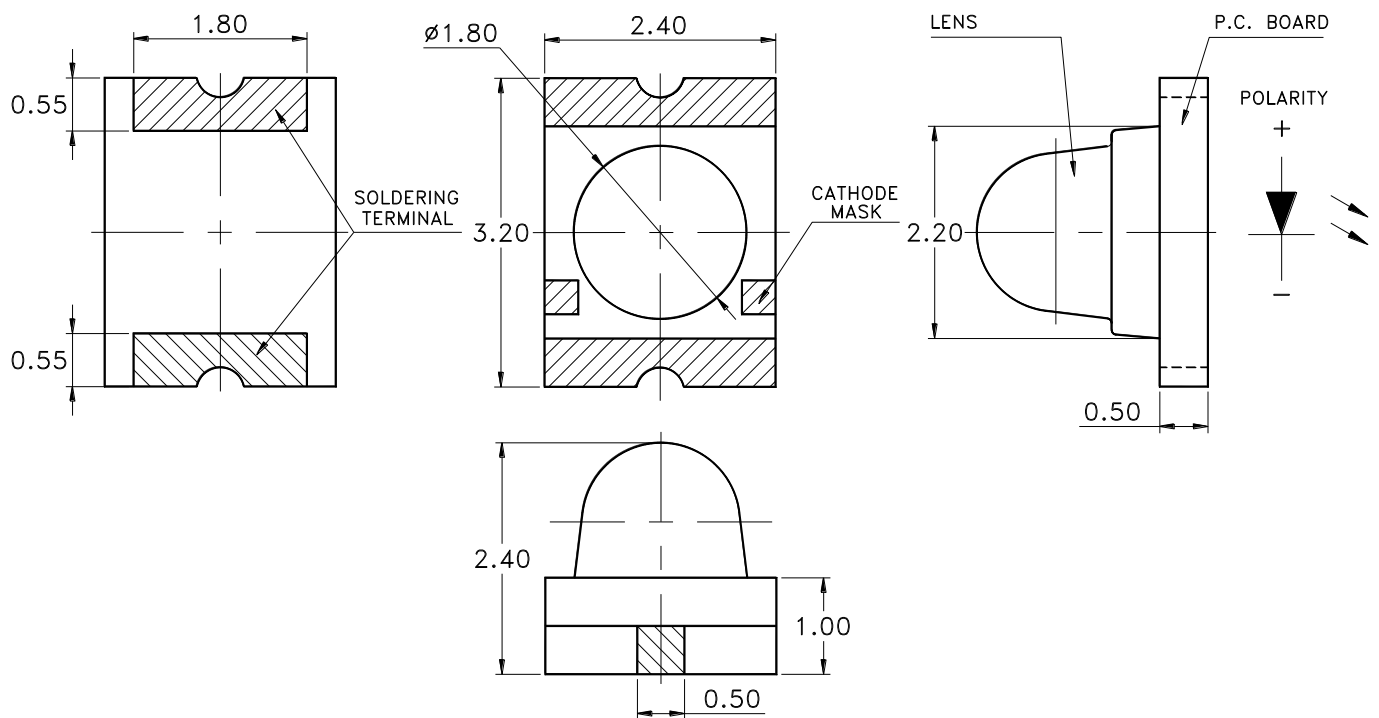
PACKAGE DIMENSIONS**NOTES:**

1. All dimensions are in millimeters (inches).
2. Tolerance is ± 0.1 mm (.004") unless otherwise noted.
3. Specifications are subject to change without notice.

ABSOLUTE MAXIMUM RATINGS AT TA=25°C

PARAMETER	MAXIMUM RATING	UNIT
Power Dissipation	75	mW
Peak Forward Current (300pps, 10 μs pulse)	500	mA
Continuous Forward Current	50	mA
Reverse Voltage	5	V
Operating Temperature Range	-25°C to + 85°C	
Storage Temperature Range	-55°C to + 85°C	
Wave Soldering Condition	260°C for 5 Seconds	
Infrared Reflow Condition	260°C for 5 Seconds	

Suggestion IR Reflow Profile For Pb Free Process

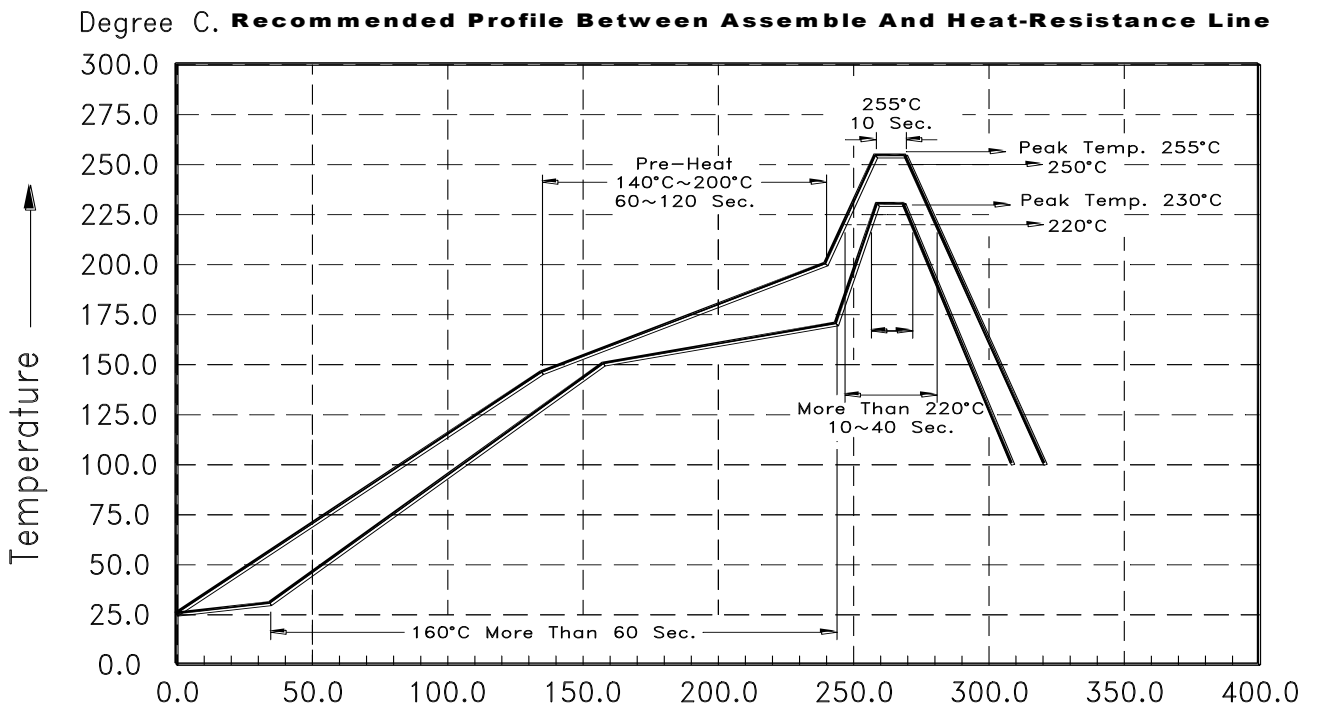

ELECTRICAL / OPTICAL CHARACTERISTICS AT TA=25°C

PARAMETER	SYMBOL	MIN.	TYP.	MAX.	UNIT	TEST CONDITION
Radiant Intensity	I_E	4	9	-	mW/sr	$I_F = 20\text{mA}$
Radiant Intensity	I_E	10	22.5	-	mW/sr	$I_F = 50\text{mA}$
Peak Emission Wavelength	λ_{Peak}	-	850	-	nm	$I_F = 20\text{mA}$
Spectral Line Half-Width	$\Delta\lambda$	-	50	-	nm	$I_F = 20\text{mA}$
Forward Voltage	V_F	1.3	1.45	1.65	V	$I_F = 20\text{mA}$
Reverse Current	I_R	-	-	10	μA	$V_R = 5\text{V}$
Rise/Fall Time	T_r/T_f	-	30	-	nS	10%~90%, $I_F = 20\text{mA}$
Viewing Angle (See FIG.6)	$2\theta_{1/2}$	-	20	-	deg.	

TYPICAL ELECTRICAL / OPTICAL CHARACTERISTICS CURVES

(25°C Ambient Temperature Unless Otherwise Noted)

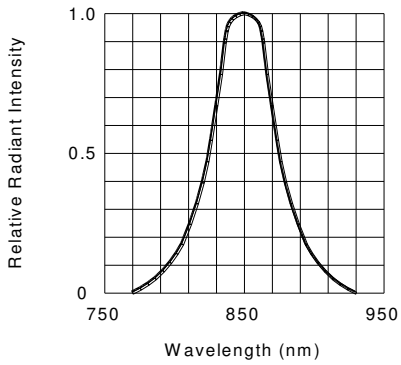

FIG.1 SPECTRAL DISTRIBUTION

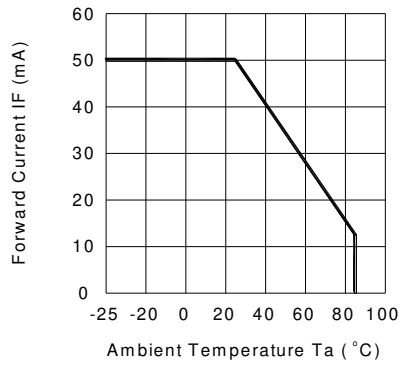

FIG.2 FORWARD CURRENT VS. AMBIENT TEMPERATURE

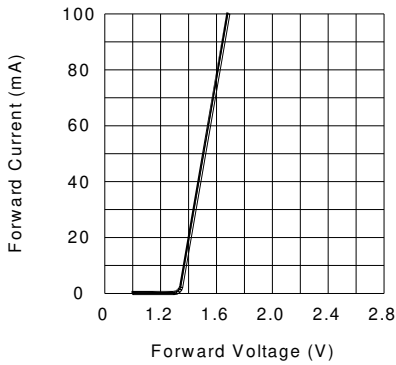

FIG.3 FORWARD CURRENT VS. FORWARD VOLTAGE

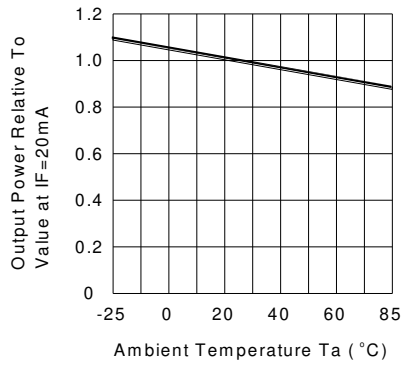

FIG.4 RELATIVE RADIANT INTENSITY VS. AMBIENT TEMPERATURE

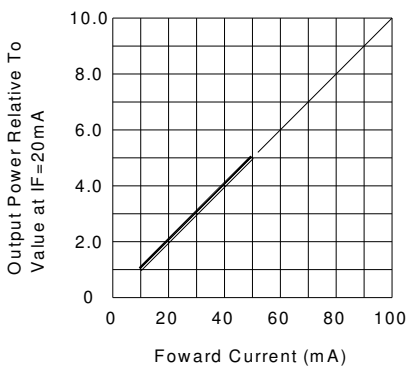

FIG.5 RELATIVE RADIANT INTENSITY VS. FORWARD CURRENT

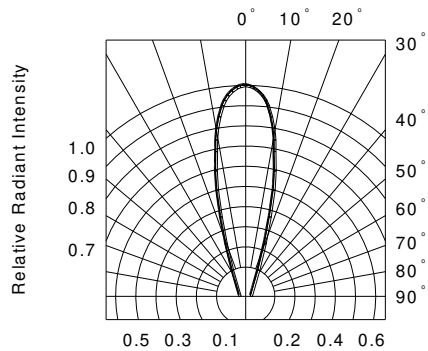
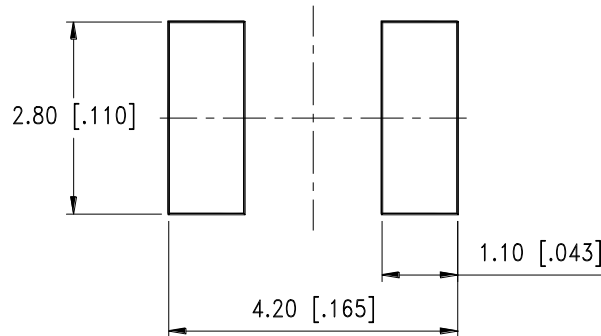
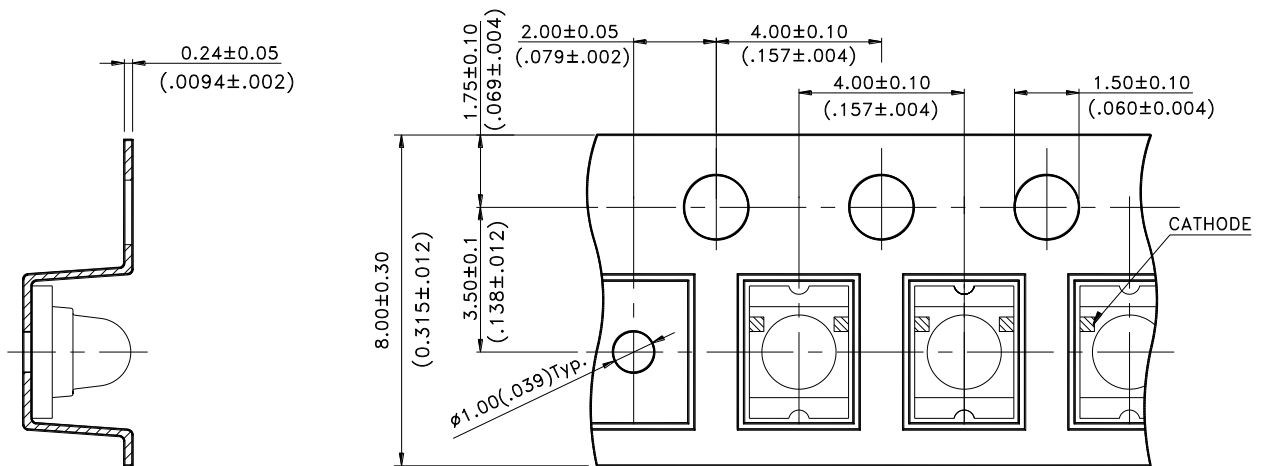

FIG.6 RADIATION DIAGRAM

CLEANING:

Do not use unspecified chemical liquid to clean LED they could harm the package.

If clean is necessary, immerse the LED in ethyl alcohol or in isopropyl alcohol at normal temperature for less one minute.

SUGGEST SOLDERING PAD DIMENSIONS**PACKAGE DIMENSIONS OF TAPE AND REEL****NOTES:**

1. All dimensions are in millimeters (inches).

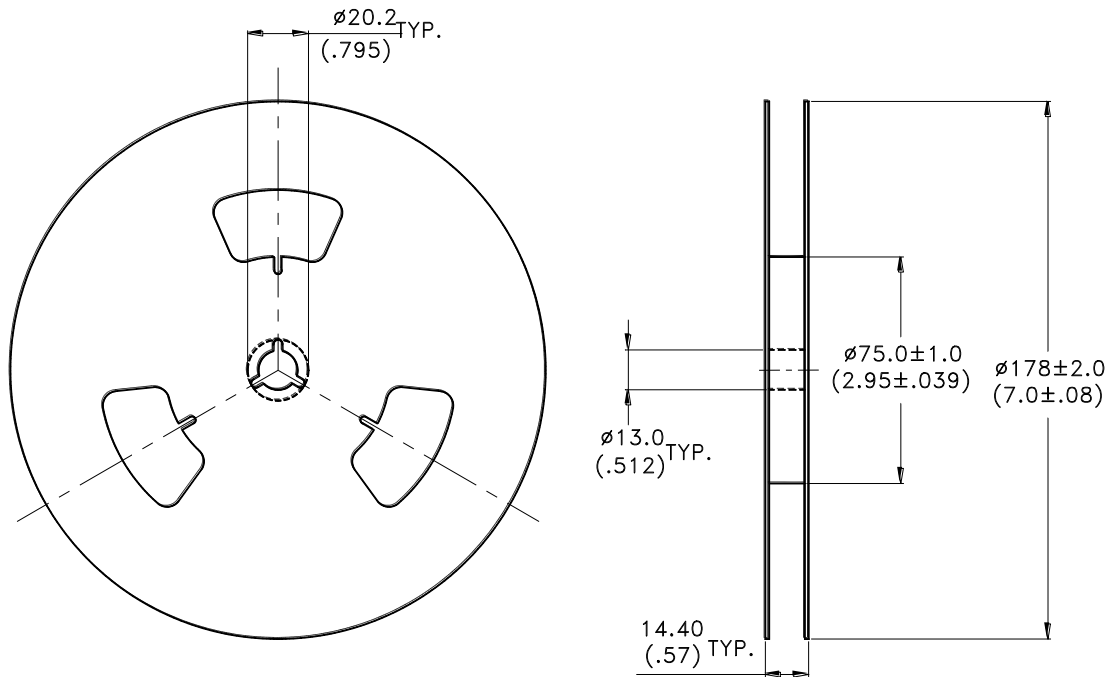
**NOTES:**

1. Empty component pockets sealed with top cover tape.
2. 7 inch reel- 1500 pieces per reel.
3. Minimum packing quantity is 500 pcs for remainders.
4. The maximum number of consecutive missing parts is two.
5. In accordance with ANSI/EIA 481-1-A-1994 specifications.

CAUTIONS

1. APPLICATION

The LEDs described here are intended to be used for ordinary electronic equipment (such as office equipment, communication equipment and household applications). Consult Liteon's Sales in advance for information on applications in which exceptional reliability is required, particularly when the failure or malfunction of the LEDs may directly jeopardize life or health (such as in aviation, transportation, traffic control equipment, medical and life support systems and safety devices).

2. STORAGE

The storage ambient for the LEDs should not exceed 30°C temperature or 70% relative humidity. It is recommended that LEDs out of their original packaging are IR-reflowed within one week. For extended storage out of their original packaging, it is recommended that the LEDs be stored in a sealed container with appropriate desiccant, or in a desiccators with nitrogen ambient. LEDs stored out of their original packaging for more than a week should be baked at about 60 deg C for at least 24 hours before solder assembly.

3. CLEANING

Use alcohol-based cleaning solvents such as isopropyl alcohol to clean the LED if necessary.

4. SOLDERING

Recommended soldering conditions:

Reflow soldering		Wave Soldering		Soldering iron	
Pre-heat	120~150°C	Pre-heat	100°C Max.	Temperature	300°C Max.
Pre-heat time	120 sec. Max.	Pre-heat time	60 sec. Max.	Soldering time	3 sec. Max.
Peak temperature	240°C Max.	Solder wave	260°C Max.		(one time only)
Soldering time	10 sec. Max.	Soldering time	10 sec. Max.		

5. DRIVE METHOD

An LED is a current-operated device. In order to ensure intensity uniformity on multiple LEDs connected in parallel in an application, it is recommended that a current limiting resistor be incorporated in the drive circuit, in series with each LED as shown in Circuit A below.

Circuit model A

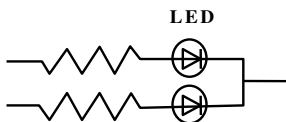

(A) Recommended circuit.

Circuit model B

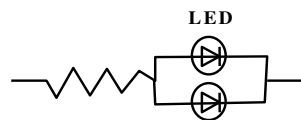

(B) The brightness of each LED might appear different due to the differences in the I-V characteristics of those LEDs.

6. OTHERS

The appearance and specifications of the product may be modified for improvement without prior notice.