

AC-DC Medical Power Module PAAM15 Series

Features:

- PCB Mountable Switching Power Module
- Fully Encapsulated Plastic Case
- Universal Input Range (90-264VAC)
- Regulated Output and Low Ripple and Noise
- <0.1W No Load Input Power
- Isolation Class II
- Small Size
- CE, CB, UL, cUL Approvals
- 3-Year Product Warranty



Description:

The PAAM15 series of encapsulated, single output, through-hole AC/DC modules is specially designed for use in medical applications. This power dense 1.08" x 2.07" platform offers up to 15W of continuous throughput across a wide range of operating temperatures whilst maintaining low emissions and high efficiency.

Model Number ¹	Max Output Wattage	Output Voltage	Output Current (mA) max	Output Line Regulation	Output Load Regulation	Ripple & Noise (mVp-p)	Max Capacitive Load (μF)	Average Efficiency @ 115VAC
PAAM15-10	15W	5V	3000	±0.5%	±1%	195	7000	79%
PAAM15-11	15W	9V	1666	±0.5%	±1%	195	5000	80%
PAAM15-12	15W	12V	1250	±0.5%	±1%	240	1500	84%
PAAM15-13	15W	15V	1000	±0.5%	±1%	300	1000	84%
PAAM15-14	15W	24V	625	±0.5%	±1%	480	470	85%

NOTES:

1. Add the letter "C" to the end of the model number for chassis mount option. Ex. "PAAM15-10C".
2. Ripple & Noise measured with 20MHz bandwidth with a 0.1μF ceramic & 47μF electrolytic capacitor across the output.
3. Safety approvals cover input frequencies of 47-63 Hz.
4. Natural convection is about 20LFM (not still air).

Specifications	
Input	
Input Voltage	90-264 VAC or 120-370 VDC, "N" to DC "+"; "L" to DC "-"
Input Frequency	47-440Hz
Input Current	385 mA max. (115 VAC) / 250 mA max. (230 VAC)
Inrush Current	20A max. (115VAC) / 40A max. (230 VAC)
Leakage Current	<0.1mA / 264 VAC (Touch Current)
External Fuse (recommend)	3.15A slow blow type
Output	
Total Output Power	Up to 15W
Voltage Accuracy	±2%
Minimum Load	0%
Line Regulation	±0.5%
Load Regulation	±1%
Hold Up Time	15ms (115VAC) / 56ms (230VAC)
Protection	
Overpower Protection	Hiccup mode, auto-recovery
Over Voltage Protection	Zener diode clamp
Short Circuit Protection	Hiccup mode, indefinite (auto-recovery)
Isolation	
Input—Output (VAC)	4000V
Environmental	
Operating Temperature	-40°C to +80°C (with derating)
Storage Temperature	-40°C to +90°C
Max Case Operating Temperature	Under 115 VAC 83°C, otherwise 90°C
Temperature Coefficient	±0.05%/°C
Altitude During Operation	5000m
Humidity	Up to 95% RH
MTBF	>350,000h at 25°C (MIL-HDBK-217F)
Atmospheric Pressure	540 hPa to 1060 hPa
General Specifications	
Dimensions	2.07 x 1.08 x 0.93 Inches (52.5x27.5x23.5 mm) Chassis Mount: 2.12 x 3.78 x 1.14 Inches (53.9x96x29 mm)
Case Material	Plastic resin (flammability to UL 94V-0)
Weight	60g
Cooling Method	Free air convection
Safety	
Agency Approvals	UL 60950-1, CAN/CSA C22.2 No. 60950-1-07 ANSI/AAMI ES60601-1 (2005 + C1:09 + A2:10), CAN/CSA-C22.2 No. 60601-1 (2008), 2 x MOPP IEC 60950-1:2005 (2nd Edition) + Am 1:2009 + Am 2:2013 IEC 60601-1:2005 (3rd Edition) + CORR. 1 (2006) + CORR. 2 (2007) + AM1 (2012) or IEC 60601-1 (2012 reprint), 2 x MOPP
*Consult with TT Electronics for information on additional country safety approvals	
EMC	
EMI (Conducted & Radiated Emissions) EMS	EN 55011 Class B EN 60601-1-2 Ed. 4
*EMC filtering occurs internally within the module	

MECHANICAL DIMENSION

Diagrams

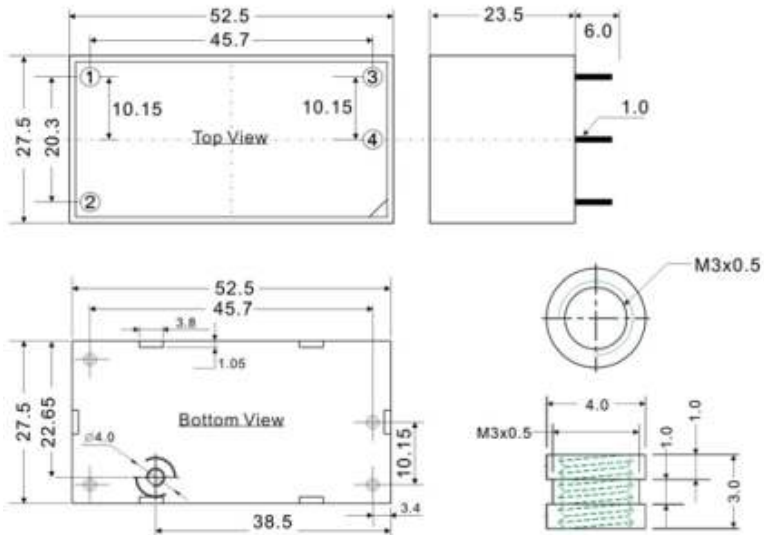

PIN#	Single
1	AC IN (L)
2	AC IN (N)
3	+DC OUT
4	-DC OUT

Maximum Torque 12 { 1.2 1 } (kg f . cm { N.m })

BLOCK DIAGRAM

Single Output

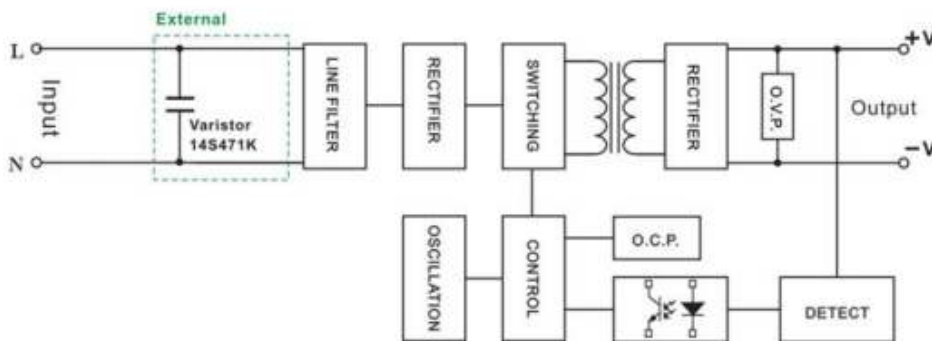

DERATING

