

REV.	DATE	ECR NO.	DESCRIPTION
NC	10/21/11	XXXXXX	INITIAL RELEASE

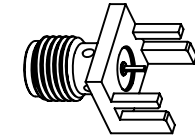
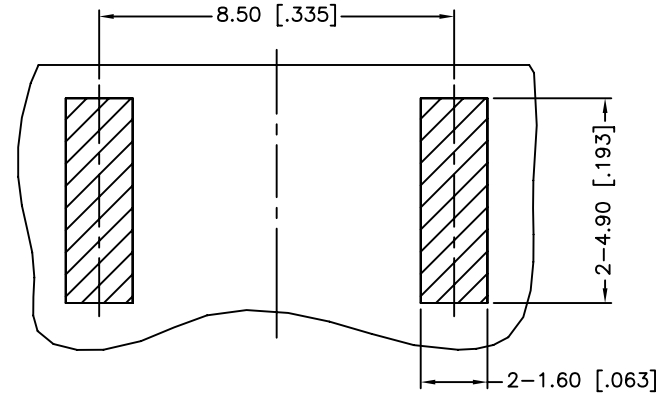
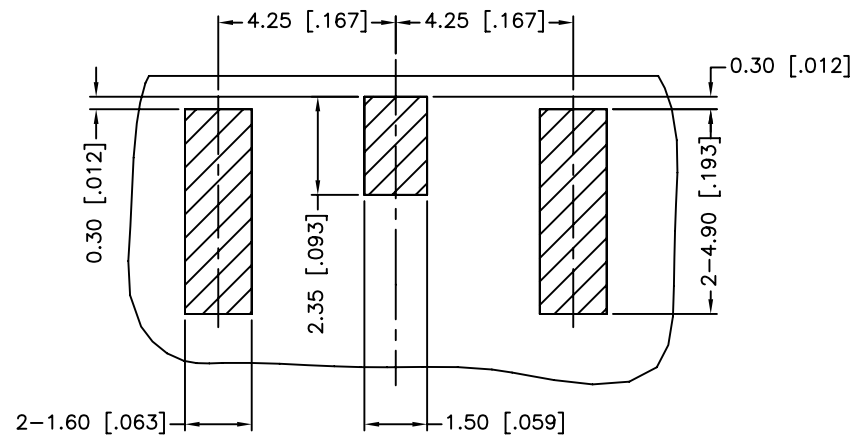

BOTTOM VIEW

RECOMMENDED PCB LAYOUT

TOP VIEW

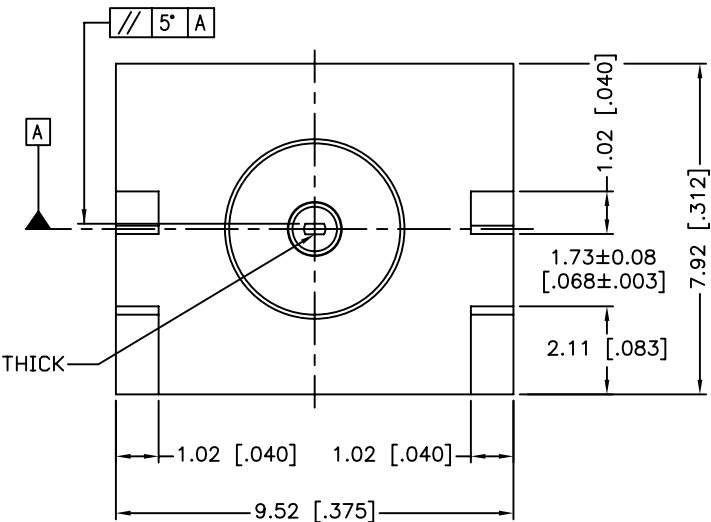
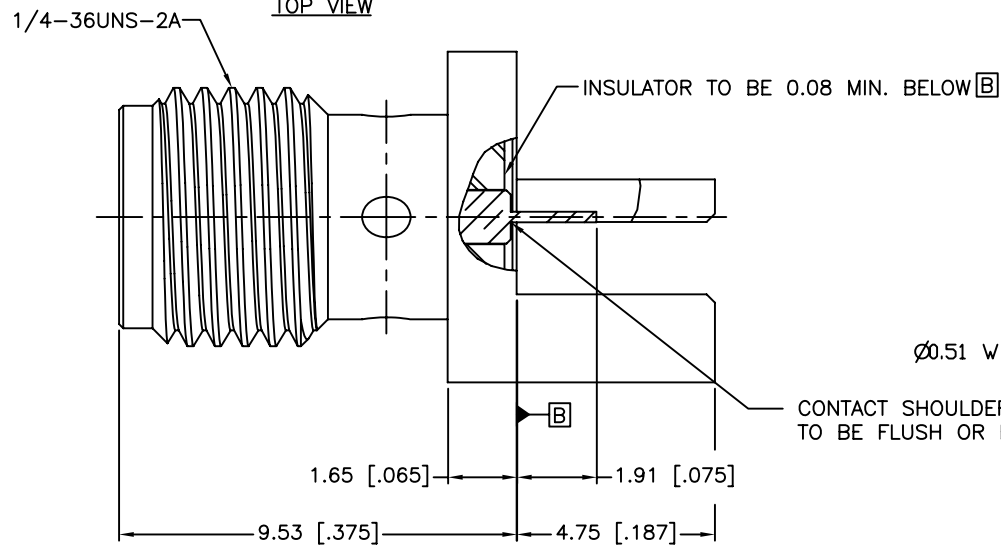

1. IMPEDANCE: 50 OHM
2. FREQUENCY RANGE: DC 0-18 GHZ
3. VSWR: NOT APPLICABLE
4. INSERTION LOSS: NOT APPLICABLE
5. DIELECTRIC WITHSTANDING VOLTAGE: 1000 VRMS, MIN.
6. DURABILITY: 500 CYCLES MIN.
7. CONTACT PIN MUST WITHSTAND 6 LBS MIN. AXIAL IN BOTH DIRECTIONS AND 4 IN-OZ MIN. RADIAL FORCE.
8. BOTTOM OF CONTACT TO BE IN LINE WITH MOUNTING LEG WITHIN .010"
9. BOARD THICKNESS=1.57 MM [.062"]

UNLESS OTHERWISE SPECIFIED DIMENSIONS ARE IN MILLIMETERS. DIMENSIONS IN [] ARE IN INCHES AND FOR CUSTOMER REFERENCE ONLY.		APPROVALS	DATE
UNLESS OTHERWISE SPECIFIED TOLERANCES FOR MILLIMETERS ARE: 0.5 - 8mm ± 0.20mm 8 - 30mm ± 0.40mm 30 - 120mm ± 0.50mm		DRAWN M.ZHANG	10/21/11
UNLESS OTHERWISE SPECIFIED TOLERANCES FOR INCHES ARE: .020 - .315 = ± 0.007" .315 - 1.180 = ± 0.015" 1.180 - 4.724 = ± 0.020"		CHECKED	
DO NOT SCALE DRAWING		ISSUED	
		SHEET 1 OF 1	
		CAD FILE C:/CONNEX/132357-11.DWG	

Amphenol Connex

PART DESCRIPTION			
SMA END LAUNCH RECEPT. JACK, FLUSH FLANGE FLAT-TAB CONTACT(.062" BOARD THICKNESS)			
PART NO.		132357-11	
DWG. NO.	132357-11.DWG	REV.	NC
SIZE	A	SCALE	NA

DESCRIPTION	MATERIAL	FINISH	QTY
3 CONTACT PIN	BER. COPPER	GOLD	1
2 INSULATOR	PTFE	NATURAL	1
1 BODY	BRASS	GOLD	1