

---

## Features

- Low Current Consumption:  $I_{DD} < 100 \mu\text{A}$
- RC Oscillator
- Internal Reset During Power-up and Supply Voltage Drops (POR)
- “Short” Trigger Window for Active Mode
- “Long” Trigger Window for Sleep Mode
- Cyclical Wake-up of the Microcontroller in Sleep Mode
- Trigger Input
- Six Wake-up Inputs
- Reset Output
- Enable Output



---

## Digital Window Watchdog Timer

---

### U5020M

## 1. Description

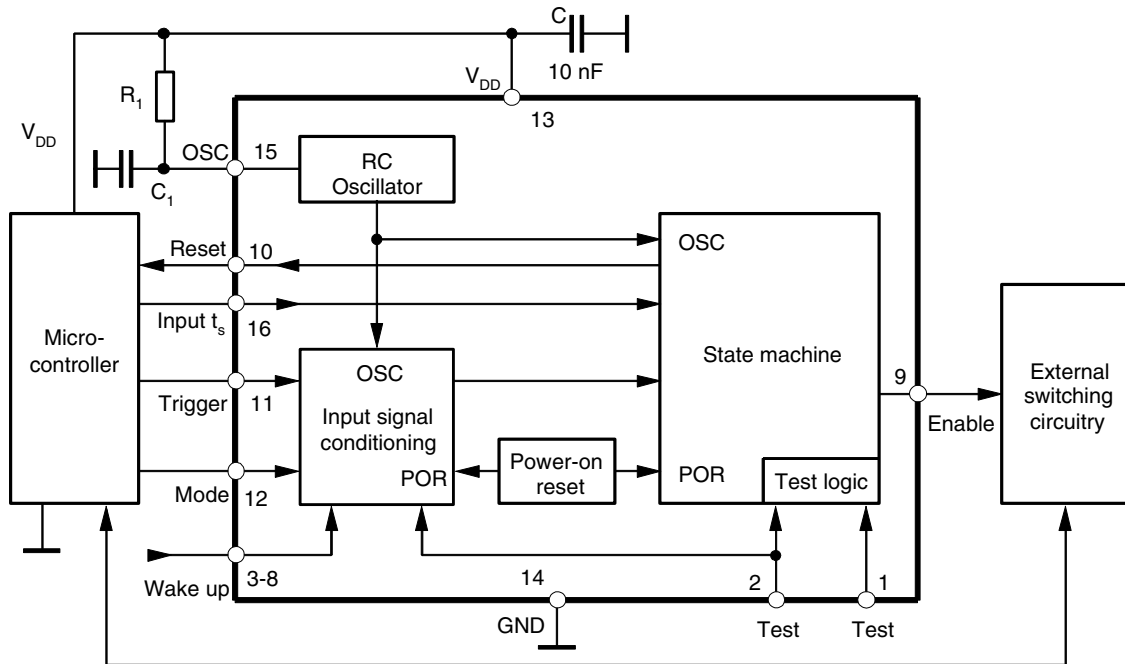
The digital window watchdog timer, U5020M, is a CMOS integrated circuit. In applications where safety is critical, it is especially important to monitor the microcontroller. Normal microcontroller operation is indicated by a cyclically transmitted trigger signal, which is received by a window watchdog timer within a defined time window.

A missing or a wrong trigger signal causes the watchdog timer to reset the microcontroller. The IC is tailored for microcontrollers which can work in both full-power and sleep mode. With an additional voltage monitoring (power-on reset and supply voltage drop reset), the U5020M offers a complete monitoring solution for microsystems in automotive and industrial applications.

Rev. 4755B-AUTO-11/05

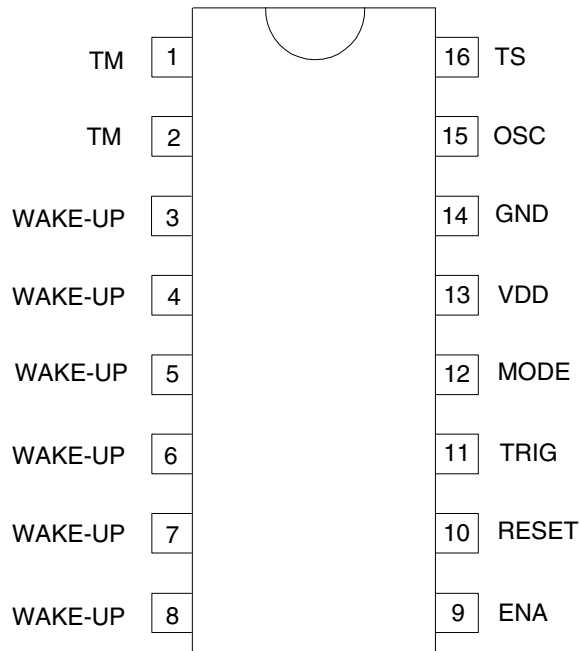


**Figure 1-1.** Block Diagram with External Circuit



## 2. Pin Configuration

**Figure 2-1.** Pinning SO16



### 3. Pin Description

Pin	Symbol	Function
1	TM	Test must not be connected
2	TM	Test must be connected to GND
3 to 8	WAKE-UP	Wake-up inputs (pull-down resistor) There are six digitally debounced wake-up inputs. During the long trigger mode each signal slope at the inputs initiates a reset pulse at pin 10.
9	ENA	Enable output (push-pull) It is used for the control of peripheral components. It is activated after the processor triggers three times correctly.
10	RESET	Reset output (open drain) Resets the processor in the case of a trigger error or if a wake-up pulse occurs during the long watchdog period.
11	TRIG	Trigger input (pull-up resistor) It is connected to the microprocessor's trigger signal.
12	MODE	Mode input (pull-up resistor) The processor's mode signal initiates the switchover between the long and the short watchdog time.
13	VDD	Supply voltage
14	GND	Ground, reference voltage
15	OSC	RC oscillator
16	TS	Time switch input Programming pin to select different time durations for the long watchdog time.

### 4. Functional Description

#### 4.1 Supply, Pin 13

The U5020M requires a stabilized supply voltage  $V_{DD} = 5\text{ V} \pm 5\%$  to comply with its electrical characteristics.

An external buffer capacitor of  $C = 10\text{ nF}$  may be connected between pin 13 and GND.

#### 4.2 RC Oscillator, Pin 15

The clock frequency,  $f$ , can be adjusted by the components  $R_1$  and  $C_1$  according to the formula:

$$f = \frac{1}{t}$$

where  $t = 1.35 + 1.57 R_1 (C_1 + 0.01)$

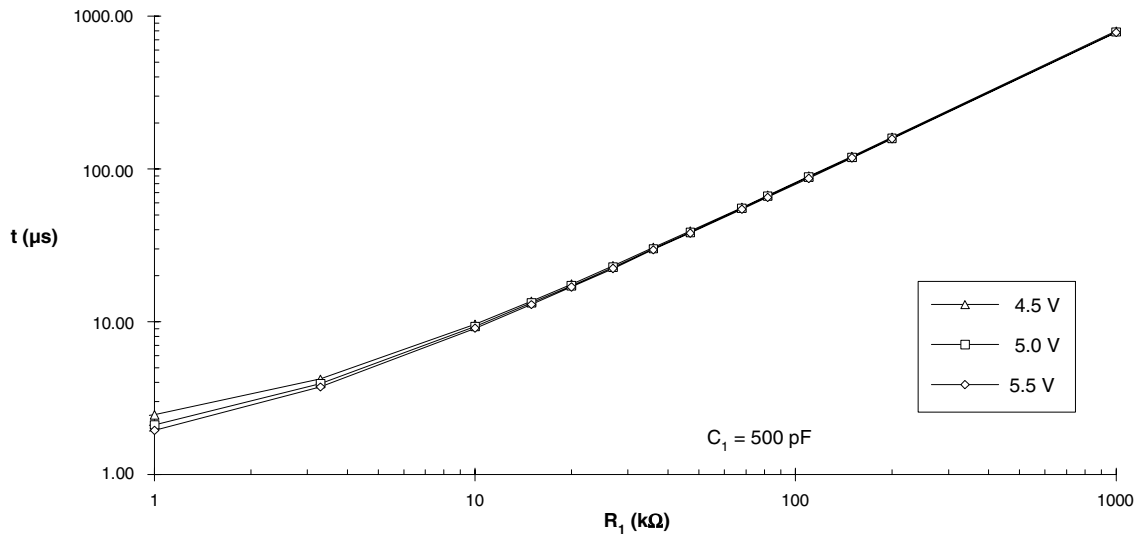
$R_1$  in  $k\Omega$ ,  $C_1$  in  $nF$  and  $t$  in  $\mu s$

The clock frequency determines all time periods of the logic part as shown in the table "Electrical Characteristics" under the subheading "Timing" on page 8. With an appropriate component selection, the clock frequency,  $f$ , is nearly independent of the supply voltage as shown in Figure 4-1 on page 4.

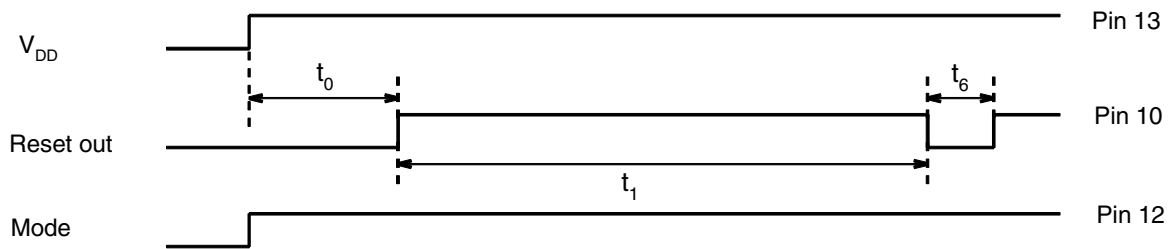
Frequency tolerance  $\Delta f_{\max} = 10\%$  with  $R_1 \pm 1\%$ ,  $C_1 = \pm 5\%$



**Figure 4-1.** Period  $t$  versus  $R_1$ , at  $C_1 = 500$  pF



**Figure 4-2.** Power-up Reset and Mode Switchover



### 4.3 Supply Voltage Monitoring, Pin 10

The integrated power-on reset (POR) circuitry sets the internal logic to a defined basic status and generates a reset pulse at the reset output, pin 10, during ramp-up of the supply voltage and in the case of voltage drops of the supply. A hysteresis in the POR threshold prevents the circuit from oscillating. During ramp-up of the supply voltage, the reset output stays active for a specified period of time ( $t_0$ ) in order to bring the microcontroller in its defined reset status (see [Figure 4-2](#)). Pin 10 has an open-drain output.

### 4.4 Switch-over Mode Time, Pin 12

The switch-over mode time enables the synchronous operation of microcontroller and watchdog. When the power-up reset time has elapsed, the watchdog has to be switched to monitoring mode by the microcontroller by a “low” signal transmitted to the mode pin (pin 12) within the time-out period,  $t_1$ . If the low signal does not occur within  $t_1$ , (see [Figure 4-2](#)) the watchdog generates a reset pulse,  $t_6$ , and the time,  $t_1$ , starts again. Microcontroller and watchdog are synchronized with the switchover mode time,  $t_1$ , each time a reset pulse is generated.

## 4.5 Microcontroller in Active Mode

### 4.5.1 Monitoring with the “Short” Trigger Window

After the switch-over mode the watchdog operates in short watchdog mode and expects a trigger pulse from the microcontroller within the defined time window,  $t_3$ , (enable time). The watchdog generates a reset pulse which resets the microcontroller if

- the trigger pulse duration is too long
- the trigger pulse is within the disable time,  $t_2$
- there is no trigger pulse

Figure 4-3 shows the pulse diagram with a missing trigger pulse.

**Figure 4-3.** Pulse Diagram with no Trigger Pulse During the Short Watchdog Time

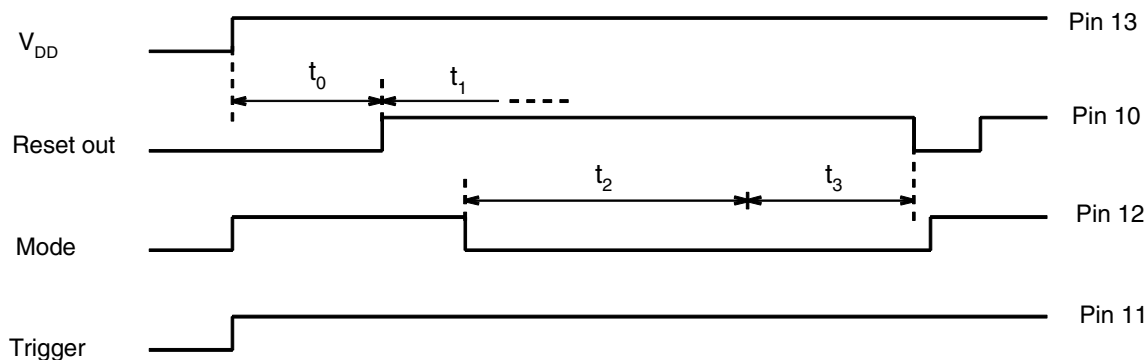


Figure 4-4 on page 6 shows a correct trigger sequence. The positive edge of the trigger signal starts a new monitoring cycle with the disable time,  $t_2$ . To ensure correct operation of the microcontroller, the watchdog needs to be triggered three times correctly before it sets its enable output. This feature is used to activate or deactivate safety-critical components which have to be switched to a certain condition (emergency status) in the case of a microcontroller malfunction. As soon as there is an incorrect trigger sequence, the enable signal is reset and it takes a sequence of three correct triggers before enable is reset.

## 4.6 Microcontroller in Sleep Mode

### 4.6.1 Monitoring with the “Long” Trigger Window

The long watchdog mode allows cyclical wake-up of the microcontroller during sleep mode. As in short watchdog mode, there is a disable time,  $t_4$ , and an enable time,  $t_5$ , in which a trigger signal is accepted. The watchdog can be switched from the short trigger window to the long trigger window with a “high” potential at the mode pin (pin 12). In contrast to the short watchdog mode, the time periods are now much longer and the enable output remains inactive so that other components can be switched off to effect a further decrease in current consumption. As soon as a wake-up signal at one of the 6 wake up inputs (pins 3 to 8) is detected, the long watchdog mode ends, a reset pulse wakes-up the sleeping microcontroller and the normal monitoring cycle starts with the mode switch-over time.

By means of a low or high potential at pin 16 (time switch), two values for the long watchdog time can be selected.

**Figure 4-4.** Pulse Diagram of a Correct Trigger Sequence During the Short Watchdog Time

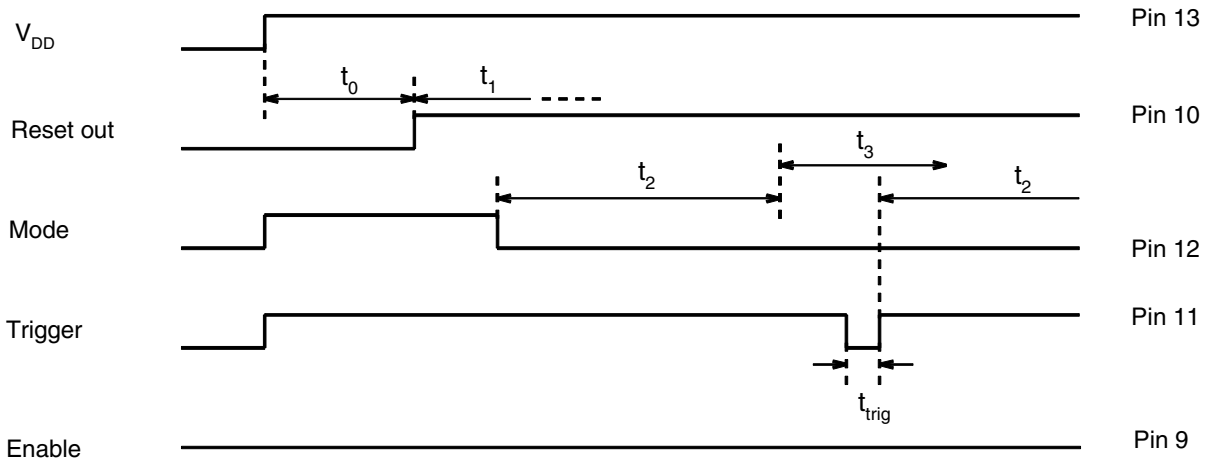
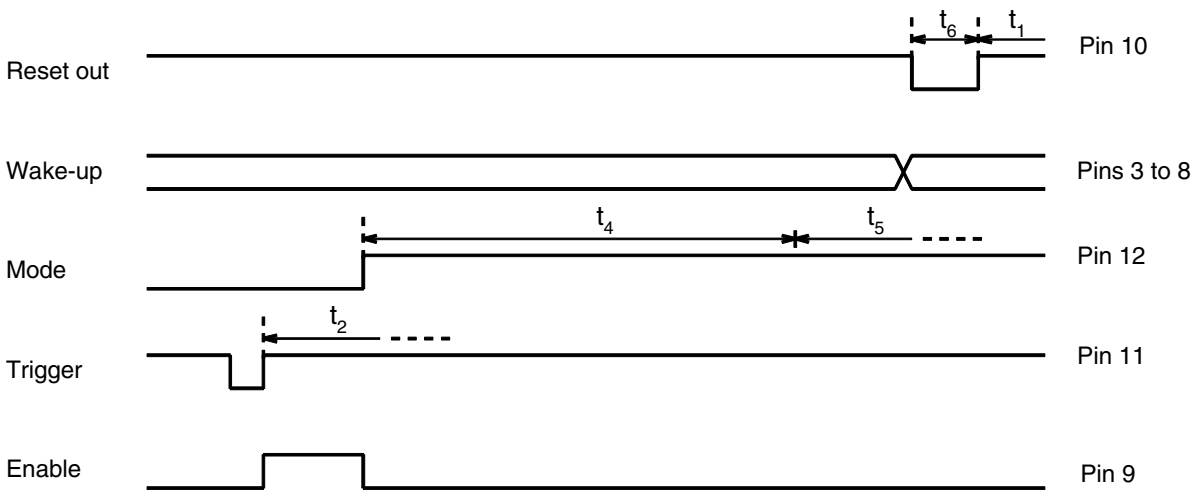


Figure 4-5 shows the switch-over from the short to the long watchdog mode. The wake-up signal during the enable time,  $t_5$ , activates a reset pulse,  $t_6$ .

The watchdog can be switched back from the long to the short watchdog mode with a low potential at the mode pin (pin 12).

**Figure 4-5.** Pulse Diagram of the Long Watchdog Time



## 5. Application Hint

In order to prevent the IC from an undesired reset output signal which may be caused by transients on the supply under certain conditions, a PC board connection from pin 2 to GND is strongly recommended.

## 6. Absolute Maximum Ratings

Stresses beyond those listed under “Absolute Maximum Ratings” may cause permanent damage to the device. This is a stress rating only and functional operation of the device at these or any other conditions beyond those indicated in the operational sections of this specification is not implied. Exposure to absolute maximum rating conditions for extended periods may affect device reliability.

Parameters	Symbol	Value	Unit
Supply voltage	$V_{DD}$	6.5	V
Output current	$I_{OUT}$	$\pm 2$	mA
Input voltage	$V_{IN}$	-0.5 V to $V_{DD} + 0.5$ V	V
Ambient temperature range	$T_{amb}$	-40 to +85	°C
Storage temperature range	$T_{stg}$	-55 to +150	°C

## 7. Thermal Resistance

Parameters	Symbol	Value	Unit
Junction ambient SO16	$R_{thJA}$	160	K/W

## 8. Electrical Characteristics

$V_{DD} = 5\text{ V}$ ;  $T_{amb} = -40^{\circ}\text{C}$  to  $+85^{\circ}\text{C}$ ; reference point is ground (pin14); [Figure 4-2 on page 4](#), unless otherwise specified

Parameters	Test Conditions	Pin	Symbol	Min.	Typ.	Max.	Unit
Supply voltage		13	$V_{DD}$	4.5		5.5	V
Current consumption	$R_1 = 66\text{ k}\Omega$	13	$I_{DD}$			100	$\mu\text{A}$
Power-on reset	Logic functions	13	$V_{DD}$	1			V
Power-on reset	Threshold	13	$V_{POR}$		3.8		V
Power-on reset	Hysteresis	13	$V_{hys}$		100		mV
<b>Inputs</b>		3 to 8, 11, 12, 16					
Upper threshold ("1")			$V_{IH}$	4.0			V
Lower threshold ("0")			$V_{IL}$			1.0	V
Input voltage range			$V_{IN}$	-0.4		$V_{DD} + 0.2$	V
Input current	Depending on pin		$I_{IN}$	-20		20	$\mu\text{A}$
<b>Output Pin 9</b>							
Maximum output current			$I_{OUT}$	2			mA
Upper output voltage ("1")	$I_{OUT} = 1\text{ mA}$		$V_{OH}$	4.5			V
Lower output voltage ("0")	$I_{OUT} = -1\text{ mA}$		$V_{OL}$			0.5	V
<b>Output Pin 10</b>							
Maximum output current			$I_{OUT}$	2			mA
Lower output voltage ("0")	$I_{OUT} = -1\text{ mA}$		$V_{OL}$			0.5	V
<b>Timing</b>							
Debounce period	Trig, Mode	11, 12		3		4	cycle
Debounce period	Wake-up 1-6	3 to 8		96		128	cycle
Maximum trigger pulse period					45		cycle
Power-up reset time			$t_0$		201		cycle
Time-out period			$t_1$		1,112		cycle
Short disable time			$t_2$		130		cycle
Short enable time			$t_3$		124		cycle
Long disable time	Input switch = low (0)	16	$t_4$		71,970		cycle
Long enable time	Input switch = low (0)	16	$t_5$		30,002		cycle
Long disable time	Input switch = high (1)	16	$t_4$		1,200		cycle
Long enable time	Input switch = high (1)	16	$t_5$		400		cycle
Reset-out time			$t_6$		40		cycle

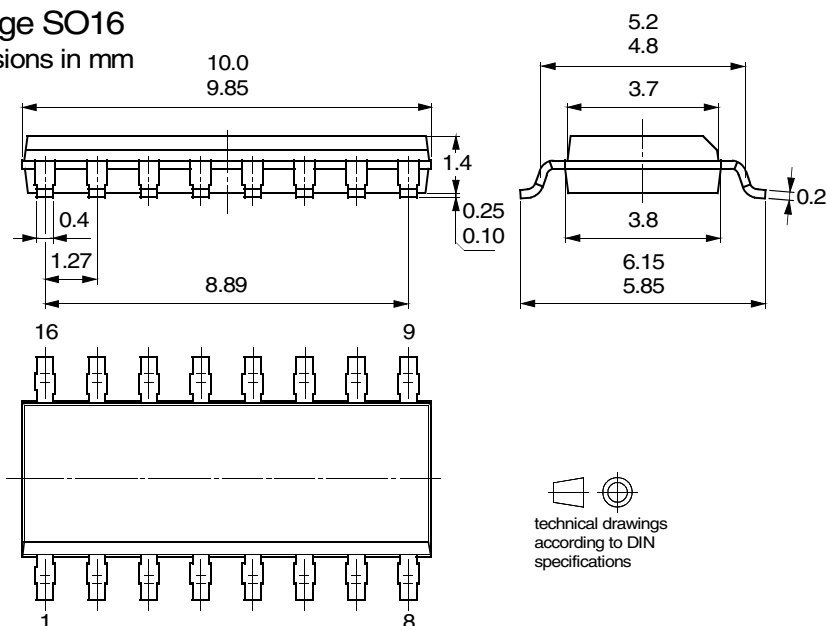


## 9. Ordering Information

Extended Type Number	Package	Remarks
U5020M-MFPY	SO16	Tubed, Pb-free
U5020M-MFPG3Y	SO16	Taped and reeled, Pb-free

## 10. Package Information

Package SO16  
Dimensions in mm



## 11. Revision History

Please note that the following page numbers referred to in this section refer to the specific revision mentioned, not to this document.

Revision No.	History
4755B-AUTO-11/05	<ul style="list-style-type: none"> <li>Put datasheet in a new template</li> <li>First page: Pb-free logo added</li> <li>Page 9: Ordering Information changed</li> </ul>



## Atmel Corporation

2325 Orchard Parkway  
San Jose, CA 95131, USA  
Tel: 1(408) 441-0311  
Fax: 1(408) 487-2600

## Regional Headquarters

### Europe

Atmel Sarl  
Route des Arsenaux 41  
Case Postale 80  
CH-1705 Fribourg  
Switzerland  
Tel: (41) 26-426-5555  
Fax: (41) 26-426-5500

### Asia

Room 1219  
Chinachem Golden Plaza  
77 Mody Road Tsimshatsui  
East Kowloon  
Hong Kong  
Tel: (852) 2721-9778  
Fax: (852) 2722-1369

### Japan

9F, Tonetsu Shinkawa Bldg.  
1-24-8 Shinkawa  
Chuo-ku, Tokyo 104-0033  
Japan  
Tel: (81) 3-3523-3551  
Fax: (81) 3-3523-7581

## Atmel Operations

### Memory

2325 Orchard Parkway  
San Jose, CA 95131, USA  
Tel: 1(408) 441-0311  
Fax: 1(408) 436-4314

### Microcontrollers

2325 Orchard Parkway  
San Jose, CA 95131, USA  
Tel: 1(408) 441-0311  
Fax: 1(408) 436-4314

La Chantrerie  
BP 70602  
44306 Nantes Cedex 3, France  
Tel: (33) 2-40-18-18-18  
Fax: (33) 2-40-18-19-60

### ASIC/ASSP/Smart Cards

Zone Industrielle  
13106 Rousset Cedex, France  
Tel: (33) 4-42-53-60-00  
Fax: (33) 4-42-53-60-01

1150 East Cheyenne Mtn. Blvd.  
Colorado Springs, CO 80906, USA  
Tel: 1(719) 576-3300  
Fax: 1(719) 540-1759

Scottish Enterprise Technology Park  
Maxwell Building  
East Kilbride G75 0QR, Scotland  
Tel: (44) 1355-803-000  
Fax: (44) 1355-242-743

### RF/Automotive

Theresienstrasse 2  
Postfach 3535  
74025 Heilbronn, Germany  
Tel: (49) 71-31-67-0  
Fax: (49) 71-31-67-2340

1150 East Cheyenne Mtn. Blvd.  
Colorado Springs, CO 80906, USA  
Tel: 1(719) 576-3300  
Fax: 1(719) 540-1759

### Biometrics/Imaging/Hi-Rel MPU/ High Speed Converters/RF Datacom

Avenue de Rochepleine  
BP 123  
38521 Saint-Egreve Cedex, France  
Tel: (33) 4-76-58-30-00  
Fax: (33) 4-76-58-34-80

---

### Literature Requests

[www.atmel.com/literature](http://www.atmel.com/literature)

**Disclaimer:** The information in this document is provided in connection with Atmel products. No license, express or implied, by estoppel or otherwise, to any intellectual property right is granted by this document or in connection with the sale of Atmel products. **EXCEPT AS SET FORTH IN ATMEL'S TERMS AND CONDITIONS OF SALE LOCATED ON ATMEL'S WEB SITE, ATMEL ASSUMES NO LIABILITY WHATSOEVER AND DISCLAIMS ANY EXPRESS, IMPLIED OR STATUTORY WARRANTY RELATING TO ITS PRODUCTS INCLUDING, BUT NOT LIMITED TO, THE IMPLIED WARRANTY OF MERCHANTABILITY, FITNESS FOR A PARTICULAR PURPOSE, OR NON-INFRINGEMENT. IN NO EVENT SHALL ATMEL BE LIABLE FOR ANY DIRECT, INDIRECT, CONSEQUENTIAL, PUNITIVE, SPECIAL OR INCIDENTAL DAMAGES (INCLUDING, WITHOUT LIMITATION, DAMAGES FOR LOSS OF PROFITS, BUSINESS INTERRUPTION, OR LOSS OF INFORMATION) ARISING OUT OF THE USE OR INABILITY TO USE THIS DOCUMENT, EVEN IF ATMEL HAS BEEN ADVISED OF THE POSSIBILITY OF SUCH DAMAGES.** Atmel makes no representations or warranties with respect to the accuracy or completeness of the contents of this document and reserves the right to make changes to specifications and product descriptions at any time without notice. Atmel does not make any commitment to update the information contained herein. Unless specifically provided otherwise, Atmel products are not suitable for, and shall not be used in, automotive applications. Atmel's products are not intended, authorized, or warranted for use as components in applications intended to support or sustain life.

© Atmel Corporation 2005. All rights reserved. Atmel®, logo and combinations thereof, Everywhere You Are® and others, are registered trademarks or trademarks of Atmel Corporation or its subsidiaries. Other terms and product names may be trademarks of others.



Printed on recycled paper.