

NOTES:

1. MATERIALS AND FINISHES:

- BODY, COUPLING NUTS - BRASS, NICKEL PLATING
- CONTACT - BRASS, GOLD PLATING
- RETAINING RING - SUS 304 & PHOSPHORBRONZE, NATURAL & NICKEL PLATING
- INSULATORS - PTFE, NATURAL
- GASKETS - SILICONE RUBBER, RED

2. ELECTRICAL:

- A. IMPEDANCE: 50 OHM
- B. FREQUENCY RANGE: DC-18 GHz
- C. VSWR(RETURN LOSS): 1.20 (21 dB) MAX @ DC-18 GHz
- D. DIELECTRIC WITHSTANDING VOLTAGE: 1000 VRMS, MIN.

3. MECHANICAL:

- A. DURABILITY: 500 CYCLES MIN.
- B. TEMPERATURE RANGE: -65° C TO 165° C

4. PACKAGING:

- A. QUANTITY: SINGLE PACK
- B. MARKING: PACKAGING TO BE MARKED  
"AMPHENOL RF, AD-TNCPSMAP-1 & DATE CODE"

THIRD ANGLE PROJ.

REVISIONS

REV	DESCRIPTION	DATE	ECN	APPR
A	RELEASE TO MFG.	06-MAR-20	14623	EH

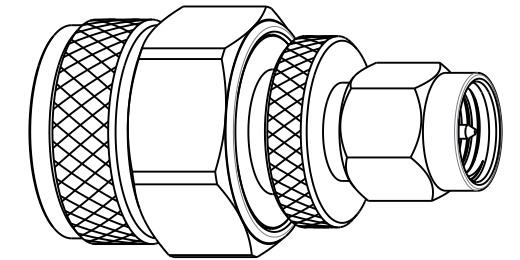

SCALE 2.000

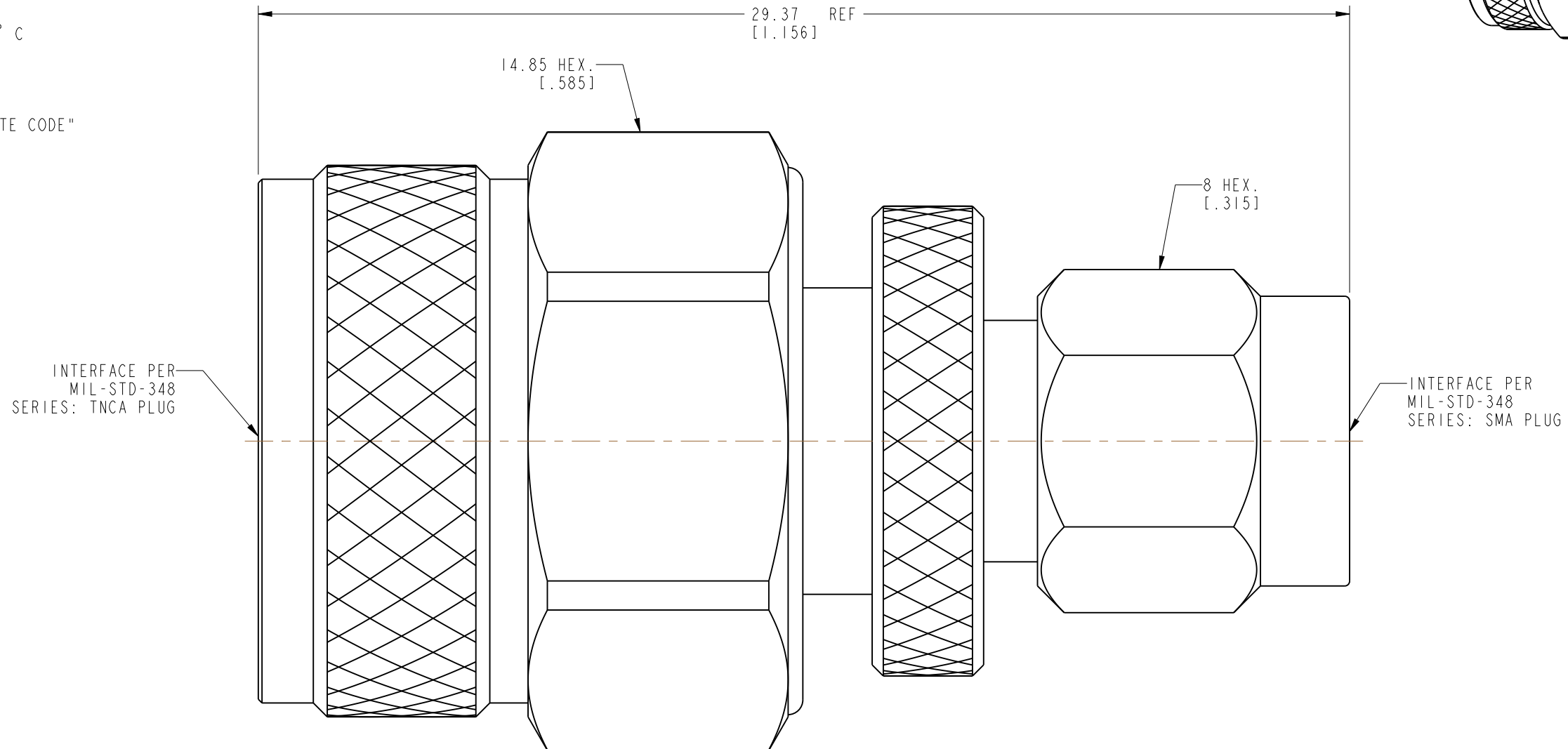

**CUSTOMER OUTLINE DRAWING**

ALL OTHER SHEETS ARE FOR INTERNAL USE ONLY

<p>UNLESS OTHERWISE SPECIFIED, DIMENSIONS ARE IN METRIC AND TOLERANCES ARE:                  &lt;0.5mm ±0.05mm    0.5 - 6mm ±0.1mm    6 - 30mm ±0.2mm    30 - 120mm ±0.3mm    ANGLES ±1°</p>	MATERIAL	DRAWN	DATE	<p>TITLE                  PERFORMANCE GRADE                  TNC PLUG TO SMA PLUG                  ADAPTER</p>	<p>Amphenol RF                  www.amphenolrf.com</p>
	REFERENCE	B. WYMAN	04-Dec-18		
<p>NOTICE - These drawings, specifications, or other data (1) are, and remain the property of Amphenol corp. (2) must be returned upon request; and (3) are confidential and not to be disclosed to any person other than those to whom they are given by Amphenol Corp. the furnishing of these drawings, specifications, or other data by Amphenol Corp., or to any other person to anyone for any purpose is not to be regarded by implication or otherwise in any manner licensing, granting rights to permitting such holder or any other person to manufacture, use or sell any product, process or design, patented or otherwise, that may in any way be related to or disclosed by said drawings, specifications, or other data.</p>	EAR# 8674	ENGINEER	DATE	<p>SCALE: 7.0:1.0   SHEET 2 OF 2</p>	DRAWING NO. AD-TNCPSMAP-1
	REF: ---	B. WYMAN	04-Dec-18		REV
	CONFIGURATION LEVEL: In Work	M. HOYACK	APPROVED	DATE	DWG SIZE
FINISH		CAD FILE	06-MAR-20	B	A