

DCNEVT500 SERIES HIGH CURRENT HIGH VOLTAGE DC CONTACTOR RELAY



Description

High current and high voltage DC contactor relays for electric vehicle, hybrid electric vehicle, circuit protection, battery switch disconnect, and main transfer switch. The Coil Economizer greatly reduces coil power and heating after the contactor is energized. Once the contactor is energized, it takes minimal coil power to keep the contacts closed due to Pulse Width Modulation (PWM) reducing the average power delivered by pulsing the electrical signal. Utilizes polarized contacts for optimum performance amidst polarized electrical loads.

Features and Benefits

- High current (500A) and high voltage (1800V) contactor for EV applications
- Dual Coil Economizer greatly reduces coil power and heating
- Hermetically sealed contact chamber to protect all moving parts
- Optional auxiliary contacts available
- 360KW power switch capable
- Designed and manufactured under the IATF16949 certification for Automotive Quality Systems.
- Designed specifically for automotive applications.

Specifications Overview

Amperage:	500A Continuous Carry
Housing:	Nylon UL 94-V0
Voltage Rating:	1800V
Output Connectors:	M10
Ingress Protections:	IP54
Operating Temperature:	-40 to 85°C
Circuitry:	SPST NO
Coil Voltage:	B: 12V DC Nominal, 9.9 - 14V DC Working C: 24V DC Nominal, 19.7 - 28V DC Working
Max Coil Inrush Current:	B: 3.3A C: 1.7A
Size:	74mm x 54mm x 120mm
Mounting:	M5
Mounting Bolt Torque:	3-4 Nm (26-35 in-lb)
Contact Torque:	13 - 15 Nm (115- 130 in-lb)
Terminals:	M10 Silver Plated Copper
Coil Terminals:	M3.5 x 0.6
Approvals:	UL File No. E510407 Recognized

Applications

- Battery Electric Vehicles
- Hybrid Electric Vehicles
- Material Handling
- Electric Maintenance and Transport Vehicles
- Industrial Applications

Web Resources

Download 2D print and technical resources at:
littelfuse.com/DCNEVT500

Ordering Information

PART NUMBER	DESCRIPTION	COIL VOLTAGE 12V DC	COIL VOLTAGE 24V DC	BOTTOM MOUNT	AUXILIARY CONTACT SPST-NO
DCNEVT500-C	High Voltage DC Contactor Relay Bottom Mount with Polar Load Terminals		●	●	
DCNEVT500-CA	High Voltage DC Contactor Relay Bottom Mount with Auxiliary Circuit with Polar Load Terminals		●	●	●
DCNEVT500-BA	High Voltage DC Contactor Relay Bottom Mount with Auxiliary Circuit with Polar Load Terminals	●		●	●
DCNEVT500-B	High Voltage DC Contactor Relay Bottom Mount with Polar Load Terminals	●		●	

* Box Packaging Available

DCNEVT500 SERIES HIGH CURRENT HIGH VOLTAGE DC CONTACTOR RELAY

Dimensions in MM

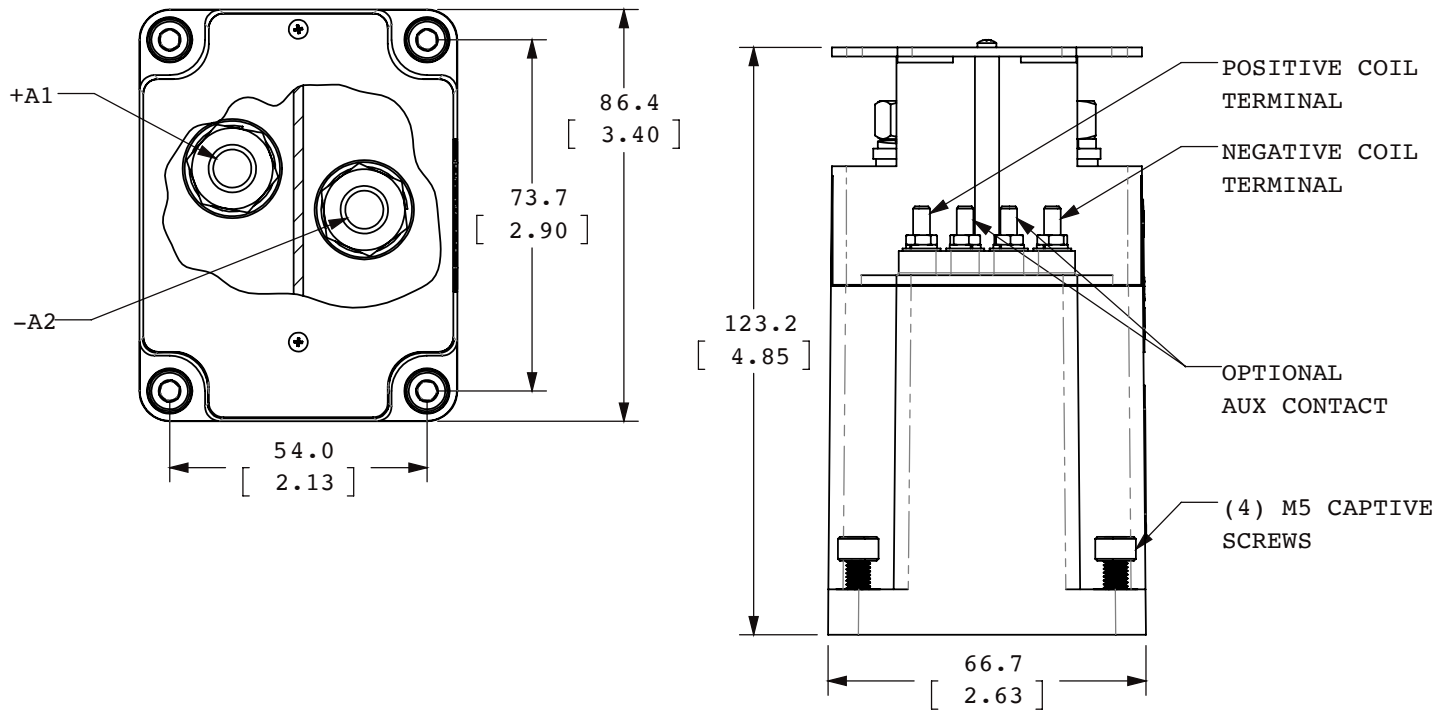

Estimated Make Break Chart

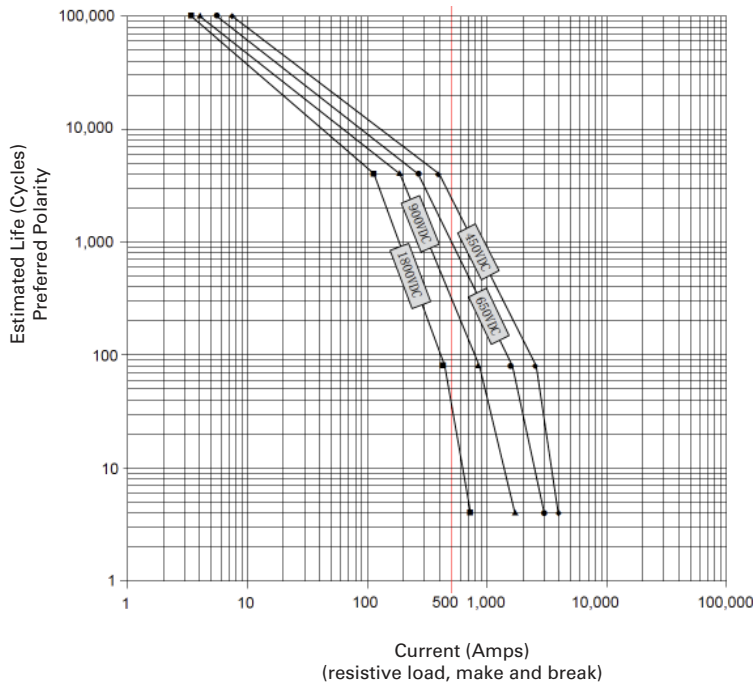

Electrical Diagram

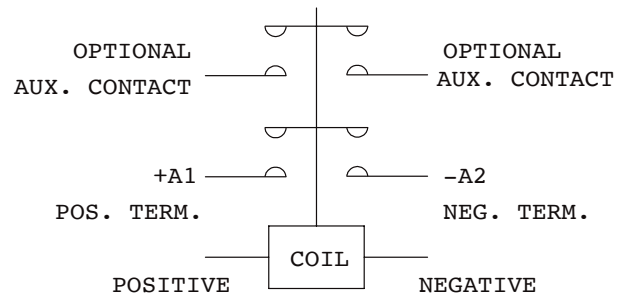

DCNEVT500 SERIES HIGH CURRENT HIGH VOLTAGE DC CONTACTOR RELAY

Performance Data

MAIN CONTACT	
Contact arrangement	1 Form X (SPST-NO, DM)
Rated Operating Voltage	12-1,800VDC
Continuous (Carry) Current	500A*1
Max short circuit current	3,300A @ 320VDC (1 cycle)
Dielectric Withstanding Voltage	Between open contacts: 4,000VDC (leakage ≤1mA) Between contact and coil: 2,200Vrms (leakage ≤1mA)
Insulation Resistance	Terminal to Terminal/Terminal to coil New: Min 100 MΩ @500Vdc
Voltage Drop (@350A)	≤70mV

COIL DATA		
Voltage rating	12Vdc	24Vdc
Pickup voltage (25°C)	9.9Vdc	19.7Vdc
Dropout voltage (25°C)	2Vdc	4Vdc
Inrush current @ nominal voltage ²	3.3A	1.7A
Holding current @ nominal voltage ²	0.74A	0.37A

MAX. BREAKING LIMIT	MAX. SHORT CIRCUIT
3,300A @ 800VDC, 1 cycle	4,000A, 1 sec

LIFE	
Electrical life	See estimated make break chart
Mechanical life	200,000 cycles

OPERATE / RELEASE TIME	
Close (includes bounce)	40ms, Max.
Release	20ms, Max.

ENVIRONMENTAL DATA	
Shock, 11ms ½ sine, operating	20G Peak
Vibration, Sine, Peak, 20G	10—1,000Hz
Operating Ambient Temperature	-40 to +85°C
Weight	3.38 lb (1.53 kg)

AUX. CONTACT	
Aux. Contact Arrangement	SPST-NO (1 Form A)
Aux. Contact Rating (Max Wattage)	10W
Aux. Contact Rating (Max Voltage)	100 VDC
Aux. Contact Resistance (Max)	500mΩ

1: Current is relevant to cross-sectional area of conductor.
2: Two coil design

Current vs Time Curve

Carry Current vs Time (25°C)

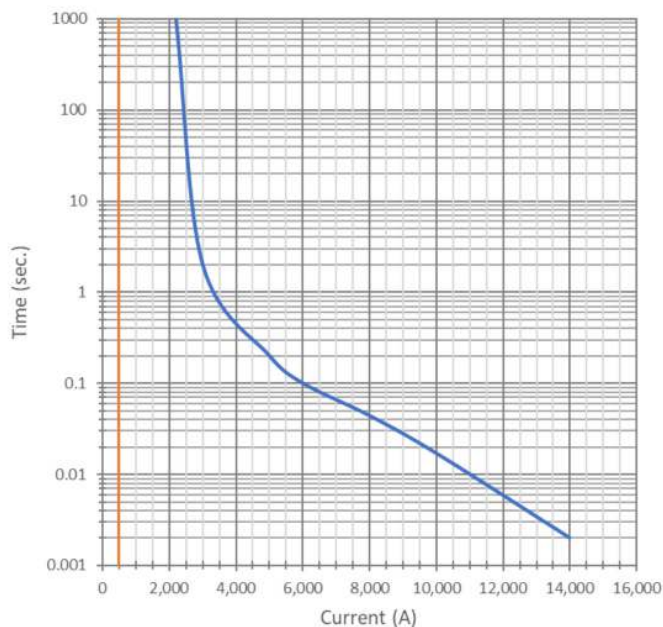

Copper Conductor: 125mm²

Application Note:

- Be sure to use washer to prevent screws from loosening, all the terminals or copper bar must be in direct contact with the contactor's terminals.
 - Contact Terminal Torque: 115 - 130 lb.in (13 - 15 N.m)
 - Mounting Torque: 26 - 35 lb.in (3 - 4 N.m)
- Contact terminals are polarized so refer to drawing during connecting. There is a reverse surge absorption circuit so that it is not necessary to use a surge protective device.
- Do not use if dropped.
- Avoid installing in a strong magnetic field (close to a transformer or magnet), or near a heat source.
- Electrical life
Use per load capability and life cycle limits so as not to cause a function failure (treat the contactor as a product with specified life and replace it when necessary). It is possible to make parts burn around the contactor once operating failure occurs. It is necessary to take layout considerations into account and to make sure power shall be cut off within 1 second.
- Avoid debris or oil contamination of the main terminals to optimize contact and avoid excess heat generation.