

# ASCB-HTC2-0A309

## 1110 Tricolor PLCC-4 LED

---

### Description

The Broadcom® ASCB-HTC2 series of RGB tricolor LEDs target indoor small pixel pitch displays. With a package size of 1.1 mm × 1.0 mm × 0.85 mm, this is the smallest Plastic Leaded Chip Carrier (PLCC) RGB LEDs package size ever produced. ASCB-HTC2 is a PLCC-4 package with a common anode footprint. The full black body appearance with diffused epoxy enhances display contrast and provides a perfect solution for high-resolution video displays.

To facilitate easy pick-and-place assembly, the LEDs are packed in tape and reel form. Every reel is shipped in single intensity and color bin to ensure uniformity.

### Features

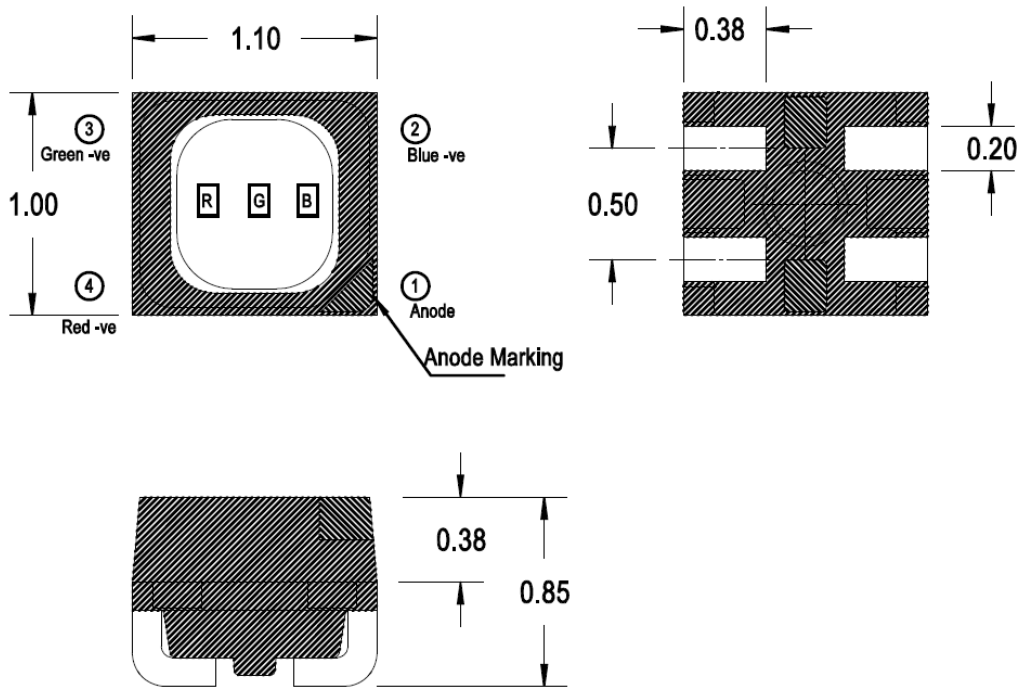
- PLCC-4 package with full black body
- Suitable for fine pitch sign

### Applications

- Indoor full-color display
- Status indicator

**CAUTION!** This LED is ESD sensitive. Observe appropriate precautions during handling and processing. Refer to application note AN-1142 for additional details.

Figure 1: Package Drawing



Pin	Configuration
1	Common Anode
2	Blue Cathode
3	Green Cathode
4	Red Cathode

**NOTE:**

1. All dimensions in millimeters (mm).
2. Tolerance is  $\pm 0.20$  mm unless otherwise specified.
3. Terminal finish = silver plating.

## Absolute Maximum Ratings

Parameters	Red	Green	Blue	Unit
DC Forward Current <sup>a</sup>	10	10	10	mA
Peak Forward Current <sup>b</sup>	100	100	100	mA
Power Dissipation	23	31	31	mW
Reverse Voltage	Not recommended for reverse-bias operation			
LED Junction Temperature	100			°C
Operating Temperature Range	-40 to +85			°C
Storage Temperature Range	-40 to +100			°C

a. Derate linearly as shown in Figure 8.

b. Duty factor = 10%, frequency = 1 kHz.

## Optical Characteristics (T<sub>J</sub> = 25°C)

Color	Luminous Intensity, I <sub>V</sub> (mcd) <sup>a</sup>			Dominant Wavelength, λ <sub>d</sub> (nm) <sup>b</sup>			Peak Wavelength, λ <sub>p</sub> (nm)	Viewing Angle, 2θ <sub>½</sub> (°) <sup>c</sup>	Test Current (mA)
	Min.	Typ.	Max.	Min.	Typ.	Max.	Typ.	Typ.	
Red	24	32	52	617	620	625	628	100	5
Green	80	120	175	527	530	535	522	100	3
Blue	13	20	29	462	467	471	463	100	3

a. The luminous intensity, I<sub>V</sub>, is measured at the mechanical axis of the package and it is tested with a single current pulse condition. The actual peak of the spatial radiation pattern may not be aligned with the axis.

b. The dominant wavelength, λ<sub>d</sub>, is derived from the CIE Chromaticity Diagram and represents the perceived color of the device.

c. θ<sub>½</sub> is the off-axis angle where the luminous intensity is half of the peak intensity.

## Electrical Characteristics (T<sub>J</sub> = 25°C)

Color	Forward Voltage, V <sub>F</sub> (V) <sup>a</sup>			Reverse Voltage, V <sub>R</sub> (V) at I <sub>R</sub> = 10 μA <sup>b</sup>
	Min.	Typ.	Max.	Min.
Red	1.60	1.95	2.30	4.0
Green	2.40	2.60	3.10	4.0
Blue	2.40	2.70	3.40	4.0

a. Forward voltage tolerance is ±0.1V. V<sub>F</sub> is tested at test current similar to optical characteristics test current.

b. Indicates product final test condition. Long term reverse bias is not recommended.

# Part Numbering System

A S C B - H T x<sub>1</sub> 2 - 0 x<sub>2</sub> x<sub>3</sub> x<sub>4</sub> x<sub>5</sub>

Code	Description	Option	
x <sub>1</sub>	Package Type	C	Full black body
x <sub>2</sub>	Minimum Intensity Bin	A	Red = Bin R1
			Green = Bin G1
			Blue = Bin B1
x <sub>3</sub>	Number of Intensity Bins	3	3 Intensity Bins from minimum
x <sub>4</sub>	Color Bin Option	0	Red = Full distribution
			Green = Bin A, B, C, D, E, F
			Blue = Bin G, H, J, K, L, M, N
x <sub>5</sub>	Test Option	9	Test Current: Red 5 mA, Green 3 mA, Blue 3 mA

## Bin Information

### Intensity Bin Limits (CAT)

Bin ID	Luminous Intensity, I <sub>v</sub> (mcd)	
	Min.	Max.
<b>Red</b>		
R1	24	30
R2	30	40
R3	40	52
<b>Green</b>		
G1	80	100
G2	100	135
G3	135	175
<b>Blue</b>		
B1	13	17
B2	17	22
B3	22	29

Tolerance = ±12%

Example of Bin information on reel and packaging label:

- CAT: R1 G2 B2 – Red intensity bin R1  
 – Green intensity bin G2  
 – Blue intensity bin B2
- BIN: AG – Green color bin A  
 – Blue color bin G

### Color Bin Limits (BIN)

Bin ID	Dominant Wavelength, (nm)	
	Min.	Max.
<b>Red</b>		
–	617	625
<b>Green</b>		
A	527	530
B	528	531
C	529	532
D	530	533
E	531	534
F	532	535
<b>Blue</b>		
G	462	465
H	463	466
J	464	467
K	465	468
L	466	469
M	467	470
N	468	471

Tolerance = ±1.0 nm

Figure 2: Spectral Power Distribution

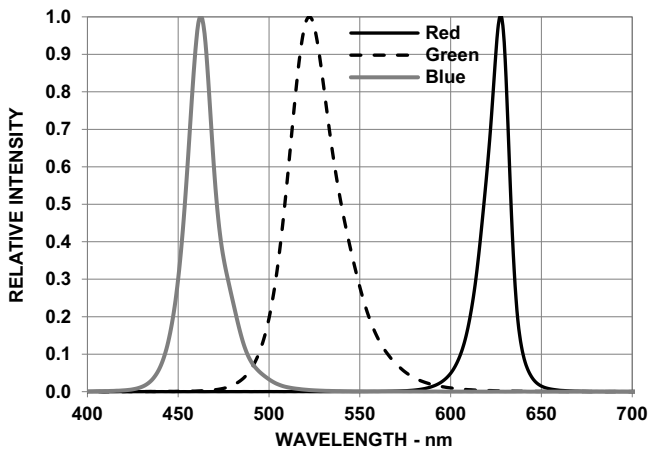


Figure 3: Forward Current vs. Forward Voltage

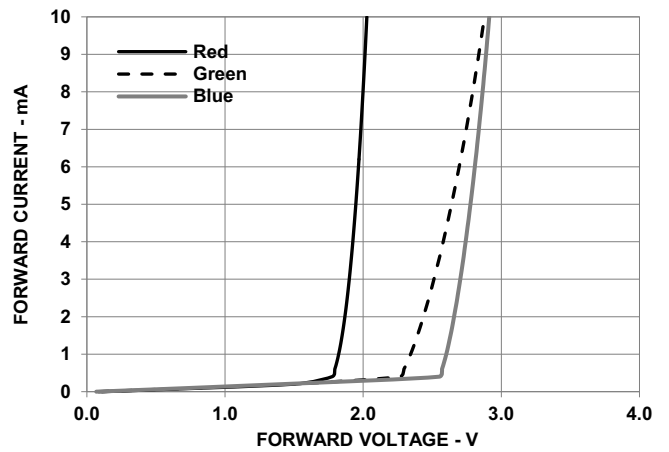


Figure 4: Relative Luminous Intensity vs. Mono Pulse Current

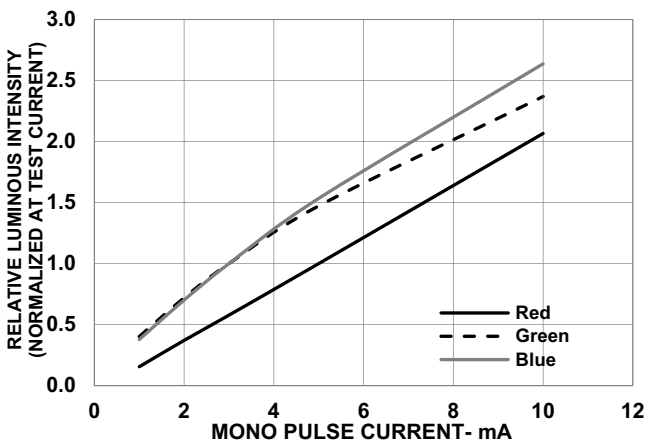


Figure 5: Dominant Wavelength Shift vs. Mono Pulse Current

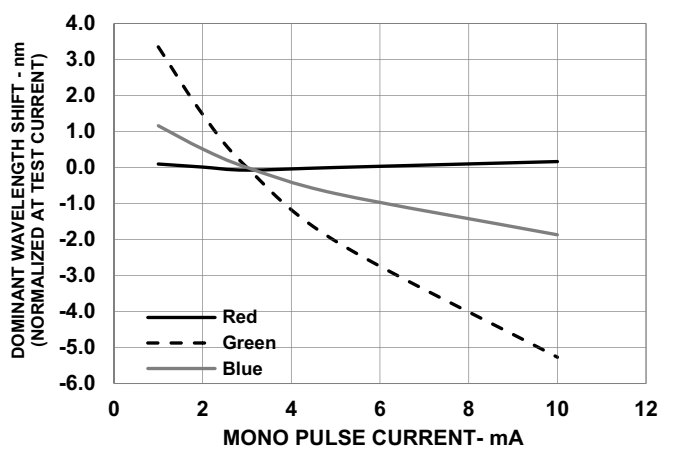


Figure 6: Relative Light Output vs. Junction Temperature

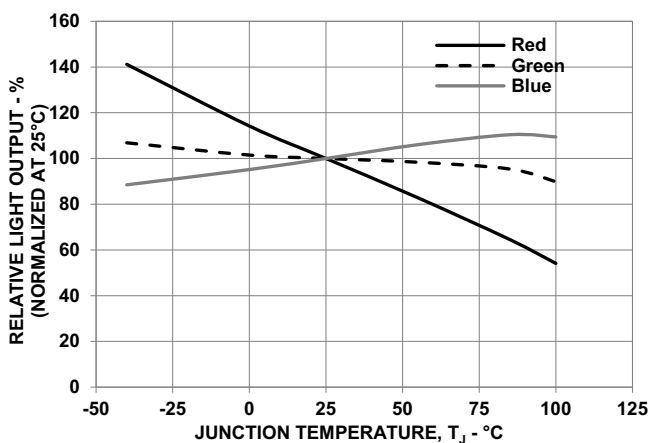
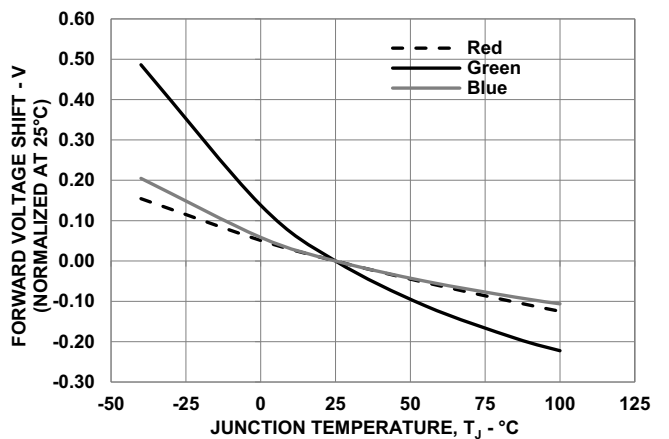
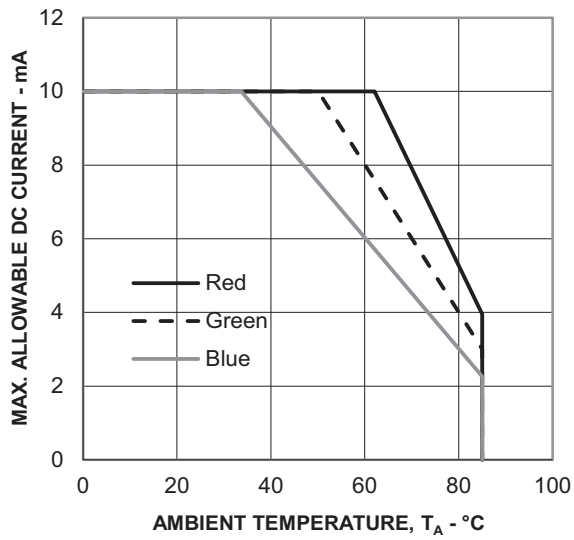


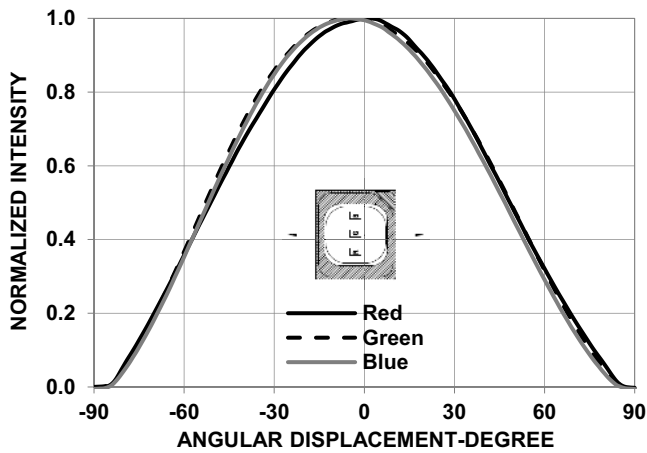
Figure 7: Forward Voltage Shift vs. Junction Temperature



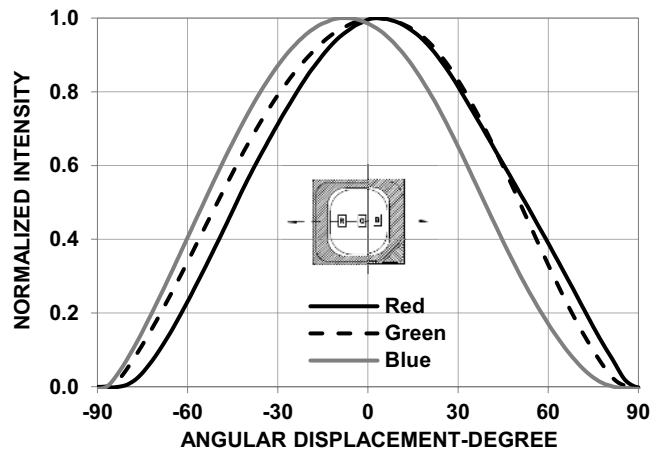
**Figure 8: Maximum Forward Current vs. Temperature for Red, Green, and Blue (Three Chips On)**



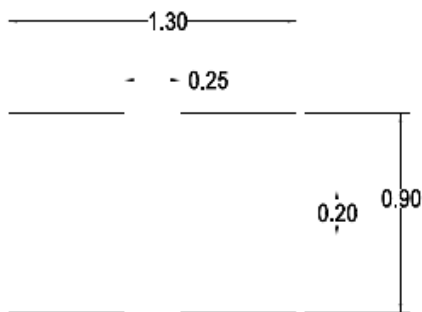
**Figure 9: Radiation Pattern for x-axis**



**Figure 10: Radiation Pattern for y-axis**

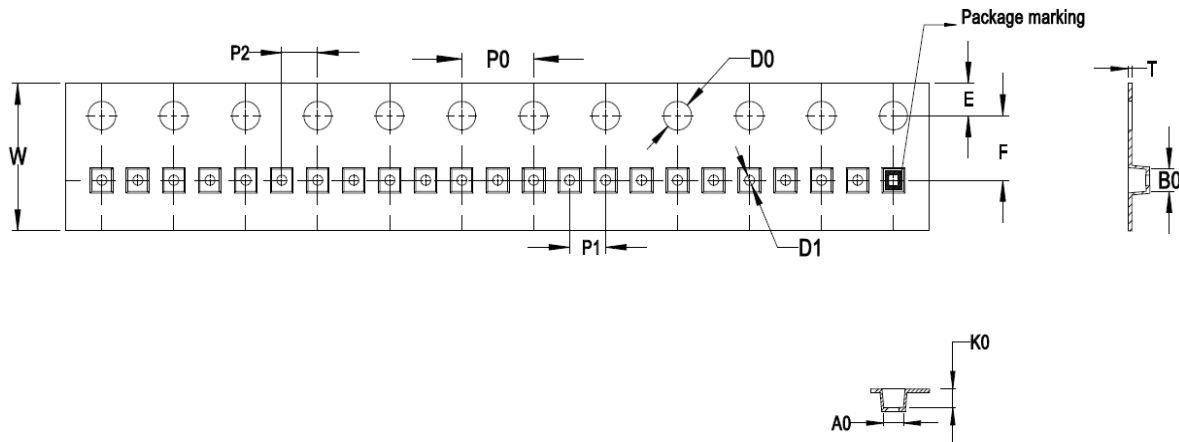


**Figure 11: Recommended Soldering Pad Pattern**



**NOTE:** All dimensions are in millimeters (mm).

**Figure 12: Carrier Tape Drawing**



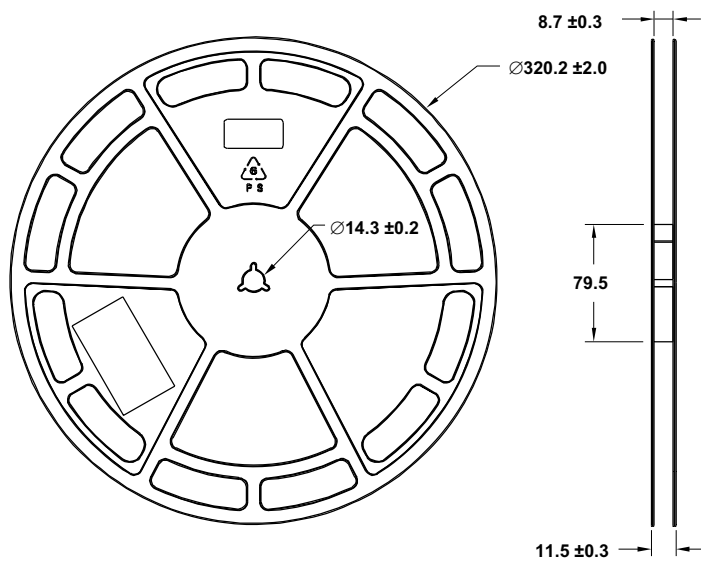
F	E1	P0	P1	P2	D0	D1	W
3.5 ±0.05	1.75 ±0.10	4.0 ±0.10	2.0 ±0.05	2.0 ±0.05	1.55 ±0.05	0.56 ±0.05	8.0 ±0.10

A0	K0	B0	T
1.1 ±0.05	1.0 ±0.05	1.2 ±0.05	0.20 ±0.02

**NOTE:**

1. All dimensions are in millimeters (mm).
2. LED quantity per reel is 30000 pieces.

**Figure 13: Reel Drawing**



**NOTE:** All dimensions are in millimeters (mm).



## Precautionary Notes

### Soldering

- Do not perform reflow soldering more than twice. Observe necessary precautions of handling moisture-sensitive device as stated in the following section.
- Do not apply any pressure or force on the LED during reflow, or after reflow when the LED is still hot.
- Use reflow soldering to solder the LED. Use hand soldering only for rework if unavoidable, but it must be strictly controlled to following conditions:
  - Soldering iron tip temperature = 315°C maximum
  - Soldering duration = 3 seconds maximum
  - Number of cycles = 1 only
  - Power of soldering iron = 50W maximum
- Do not touch the LED package body with the soldering iron except for the soldering terminals because it may cause damage to the LED.
- Confirm beforehand whether the functionality and performance of the LED is affected by soldering with hand soldering.

Figure 14: Recommended Lead-Free Reflow Soldering Profile

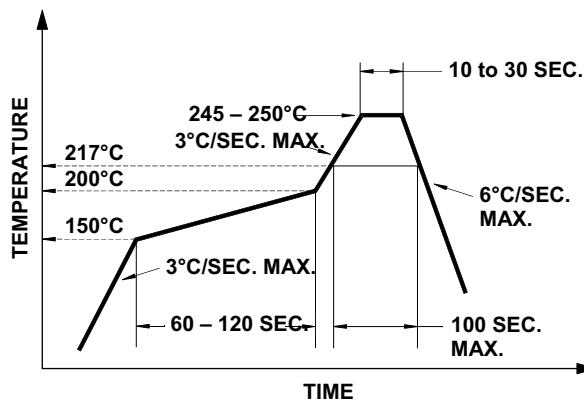
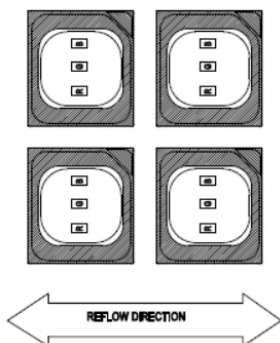


Figure 15: Recommended Board Reflow Direction



## Handling Precautions

Special handling precautions need to be observed during assembly of epoxy-encapsulated LED products. Failure to comply might lead to damage and premature failure of the LED.

- Do not stack assembled PCBs together. Use an appropriate rack to hold the PCBs.
- For automated pick-and-place, Broadcom has tested a nozzle size with OD 1.0 mm to work with this LED. However, due to the possibility of variations in other parameters such as pick-and-place machine maker/model and other settings of the machine, verify that the selected nozzle will not cause damage to the LED.

## Handling of Moisture-Sensitive Devices

This product has a Moisture Sensitive Level 5a rating per JEDEC J-STD-020. Refer to Broadcom Application Note AN5305, *Handling of Moisture Sensitive Surface Mount Devices* for additional details and a review of proper handling procedures.

- Before use:
  - An unopened moisture barrier bag (MBB) can be stored at <40°C/90% RH for 12 months. If the actual shelf life has exceeded 12 months and the Humidity Indicator Card (HIC) indicates that baking is not required, then it is safe to reflow the LEDs per the original MSL rating.
  - Do not open the MBB prior to assembly (for example, for IQC). If unavoidable, MBB must be properly resealed with fresh desiccant and HIC. The exposed duration must be taken in as floor life.
- Control after opening the MBB:
  - Read the HIC immediately upon opening of MBB.
  - Keep the LEDs at <30°C/60% RH at all times, and complete all high temperature-related processes, including soldering, curing, or rework, within 24 hours.
- Control for unfinished reel:
  - Store unused LEDs in a sealed MBB with desiccant or a desiccator at <5% RH.
- Control of assembled boards:
  - If the PCB soldered with the LEDs is to be subjected to other high-temperature processes, store the PCB in a sealed MBB with desiccant or desiccator at <5% RH to ensure that all LEDs have not exceeded their floor life of 24 hours.

- Baking is required if the following conditions exist:
  - The HIC indicator indicates a change in color for 10% and 5%, as stated on the HIC.
  - The LEDs are exposed to conditions of >30°C/60% RH at any time.
  - The LED's floor life exceeded 24 hours.

The recommended baking condition is: 65°C ±5°C for 24 hours.

Baking can only be done once.

- Storage:

The soldering terminals of these Broadcom LEDs are silver plated. If the LEDs are exposed in ambient environment for too long, the silver plating might be oxidized, thus affecting its solderability performance. As such, keep unused LEDs in a sealed MBB with desiccant or in a desiccator at <5% RH.

## Application Precautions

- The drive current of the LED must not exceed the maximum allowable limit across temperatures as stated in the data sheet. Use constant current driving to ensure consistent performance.
- The circuit design must cater to the whole range of the forward voltage ( $V_F$ ) of the LEDs to ensure the intended drive current can always be achieved.
- The LED exhibits slightly different characteristics at different drive currents, which may result in a larger variation of performance (meaning: intensity, wavelength, and forward voltage). Set the application current as close as possible to the test current to minimize these variations.
- The LED is not intended for reverse bias. Use other appropriate components for such purposes. When driving the LED in matrix form, ensure that the reverse bias voltage does not exceed the allowable limit of the LED.
- As actual application might not be exactly similar to the test conditions, verify that the LED will not be damaged by prolonged exposure in the intended environment.
- Avoid rapid changes in the ambient temperature, especially in high-humidity environments, because they cause condensation on the LED.
- If the LED is intended to be used in a harsh or an outdoor environment, protect the LED against damages caused by rain water, water, dust, oil, corrosive gases, external mechanical stresses, and so on.

## Eye Safety Precautions

LEDs may pose optical hazards when in operation. Do not look directly at operating LEDs because it might be harmful to the eyes. For safety reasons, use appropriate shielding or personal protective equipment.

## Disclaimer

Broadcom's products and software are not specifically designed, manufactured, or authorized for sale as parts, components, or assemblies for the planning, construction, maintenance, or direct operation of a nuclear facility or for use in medical devices or applications. The customer is solely responsible, and waives all rights to make claims against Broadcom or its suppliers, for all loss, damage, expense, or liability in connection with such use.

Copyright © 2022 Broadcom. All Rights Reserved. The term "Broadcom" refers to Broadcom Inc. and/or its subsidiaries. For more information, go to [www.broadcom.com](http://www.broadcom.com). All trademarks, trade names, service marks, and logos referenced herein belong to their respective companies.

Broadcom reserves the right to make changes without further notice to any products or data herein to improve reliability, function, or design. Information furnished by Broadcom is believed to be accurate and reliable. However, Broadcom does not assume any liability arising out of the application or use of this information, nor the application or use of any product or circuit described herein, neither does it convey any license under its patent rights nor the rights of others.



Lead (Pb) Free  
RoHS Compliant