

THIS DRAWING IS UNPUBLISHED. RELEASED FOR PUBLICATION  
 © COPYRIGHT - By - ALL RIGHTS RESERVED.

LOC	DIST	REVISIONS			
P	LTR	DESCRIPTION	DATE	DWN	APVD
AF	50	B	REVISEWD PER ECR-13-007151	30JUL2013	KH KR

- 1 FITS 0.31±0.025 X 4.75 [.012±.001 X .187] TAB REFER TO CP-15978 FOR DETAILS.
- 2 WIRE SIZE: 0.3-0.9MM<sup>2</sup> [22-18 AWG], STRANDED ONLY. STRIP LENGTH 7.14 [.281]
- 3 INSULATION SIZE: 4.19 [.165] MAX DIA.
- 4 CONTINUOUS STRIP,SPLICE FREE.

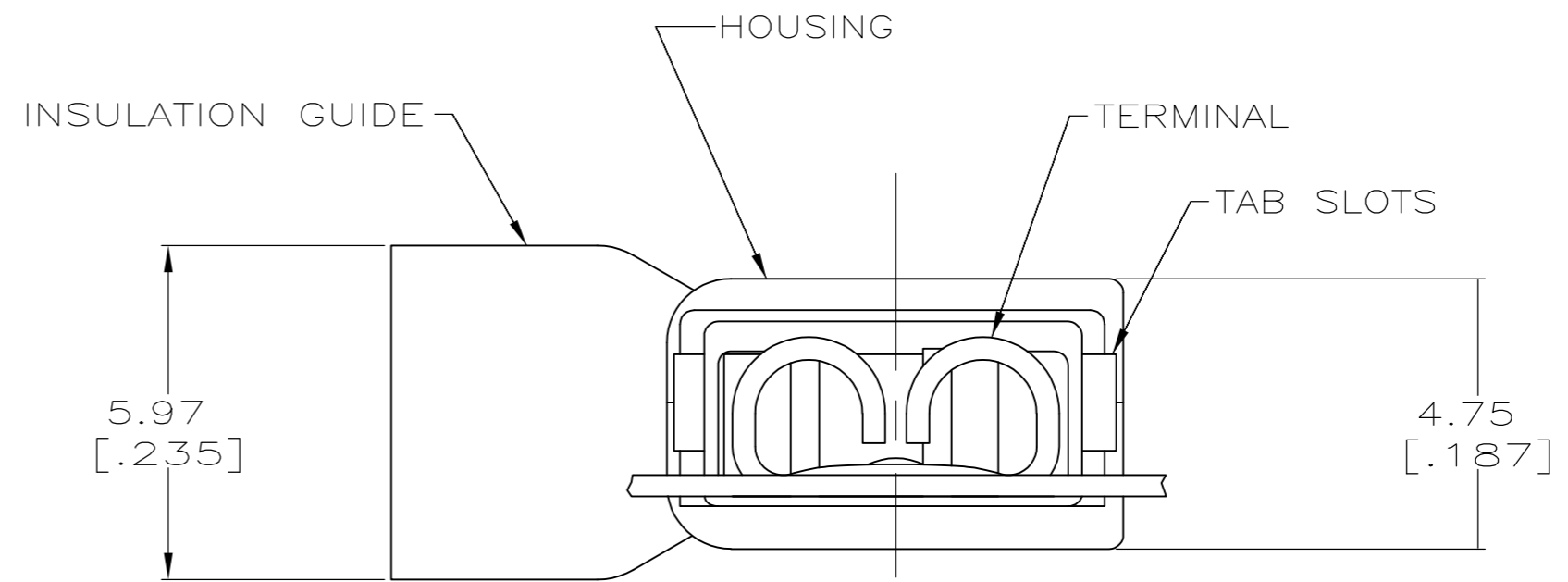
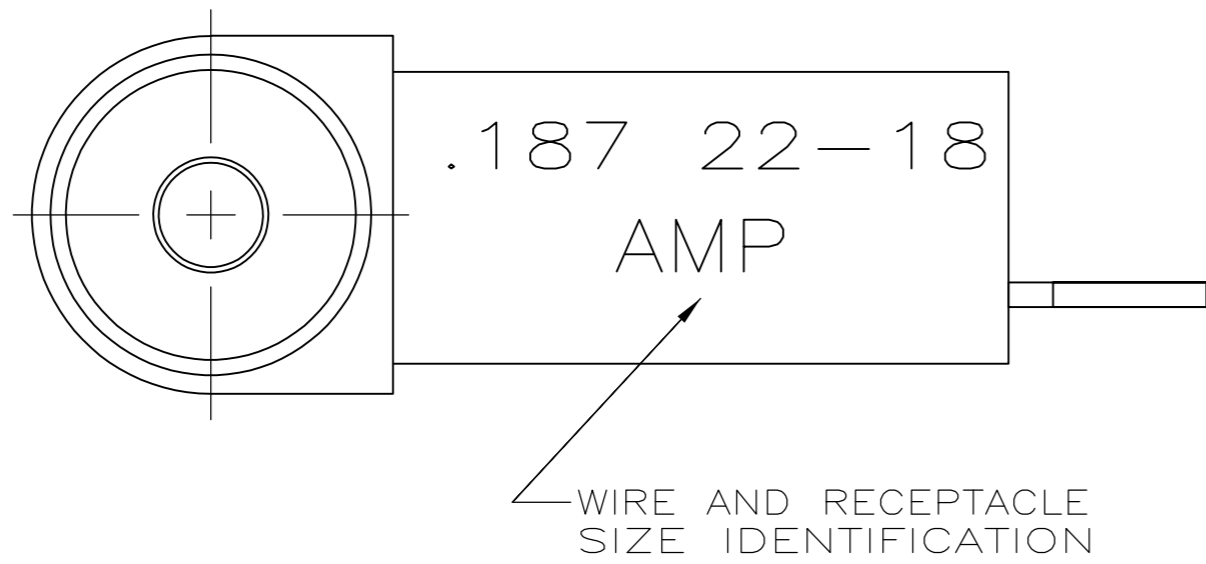
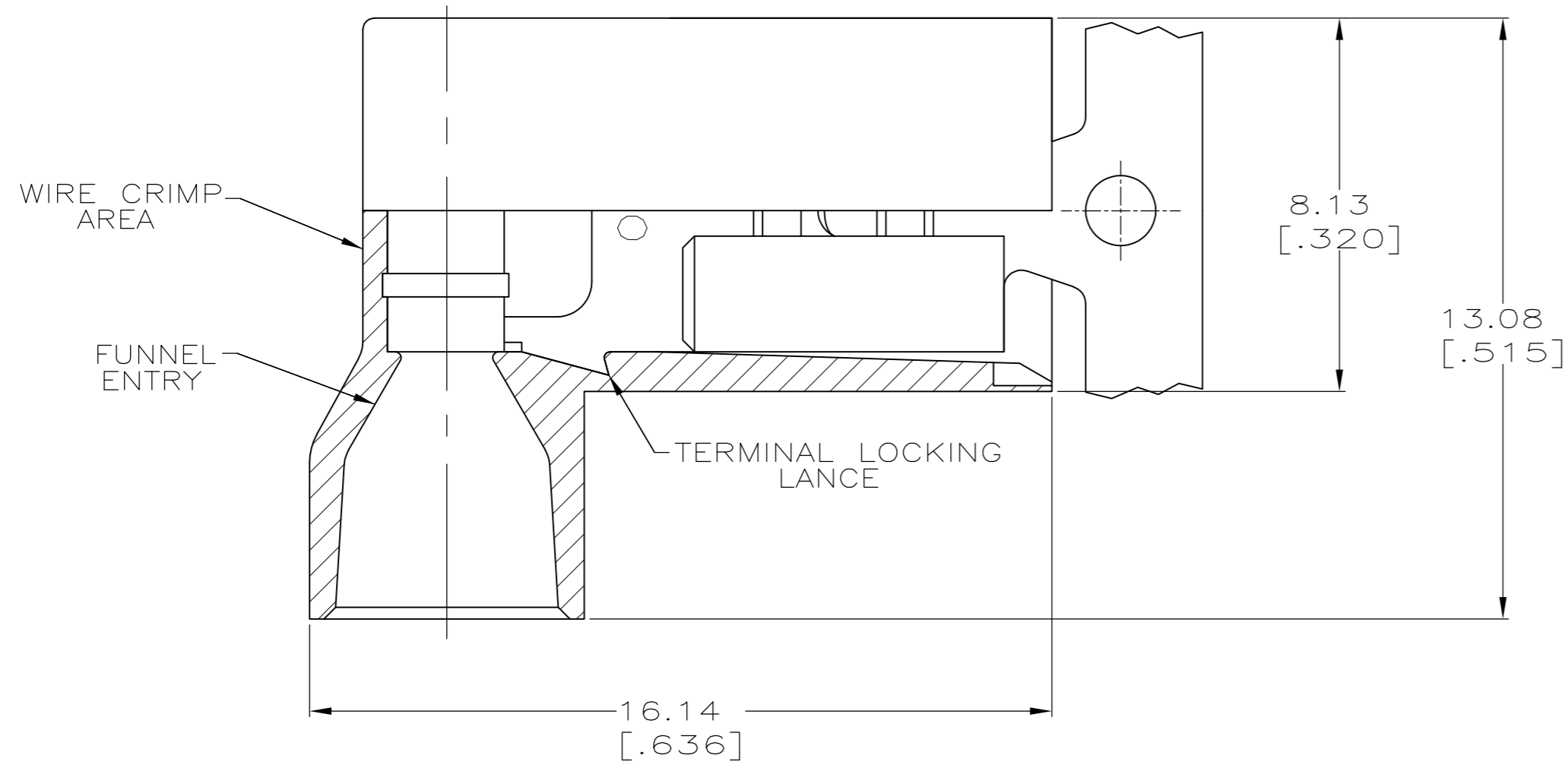

TYPE 6/6 NYLON	RED TRANSLUCENT	BRASS	0.002032 [.000080] MIN TIN PL	2-521121-2
MATERIAL	COLOR	MATERIAL	FINISH	PART NUMBER
HOUSING		TERMINAL		

THIS DRAWING IS A CONTROLLED DOCUMENT.		DWN J RUTH 9/6/96	TE Connectivity	
DIMENSIONS: mm [INCHES]		CHK MS FEHER 9/6/96		
TOLERANCES UNLESS OTHERWISE SPECIFIED:		APVD D BRATINA 9/6/96	NAME RECEPTACLE ASSEMBLY,ULTRA-FAST FLAG, 4.75 [.187] SERIES	
0 PLC ± -	1 PLC ± -	PRODUCT SPEC 108-2043	SIZE A2	CAGE CODE 00779
2 PLC ± 0.25 [.010]	3 PLC ± -	APPLICATION SPEC 114-2123	DRAWING NO C=521121	RESTRICTED TO -
4 PLC ± -	ANGLES ± -	WEIGHT -	SCALE 8:1	SHEET 1 of 1
MATERIAL SEE TABLE	FINISH SEE TABLE	CUSTOMER DRAWING		REV B