

P	LTR	DESCRIPTION	DATE	DWN	APVD
	B1	REVISED PER ECO-17-008114	07JUN2018	RS	DR

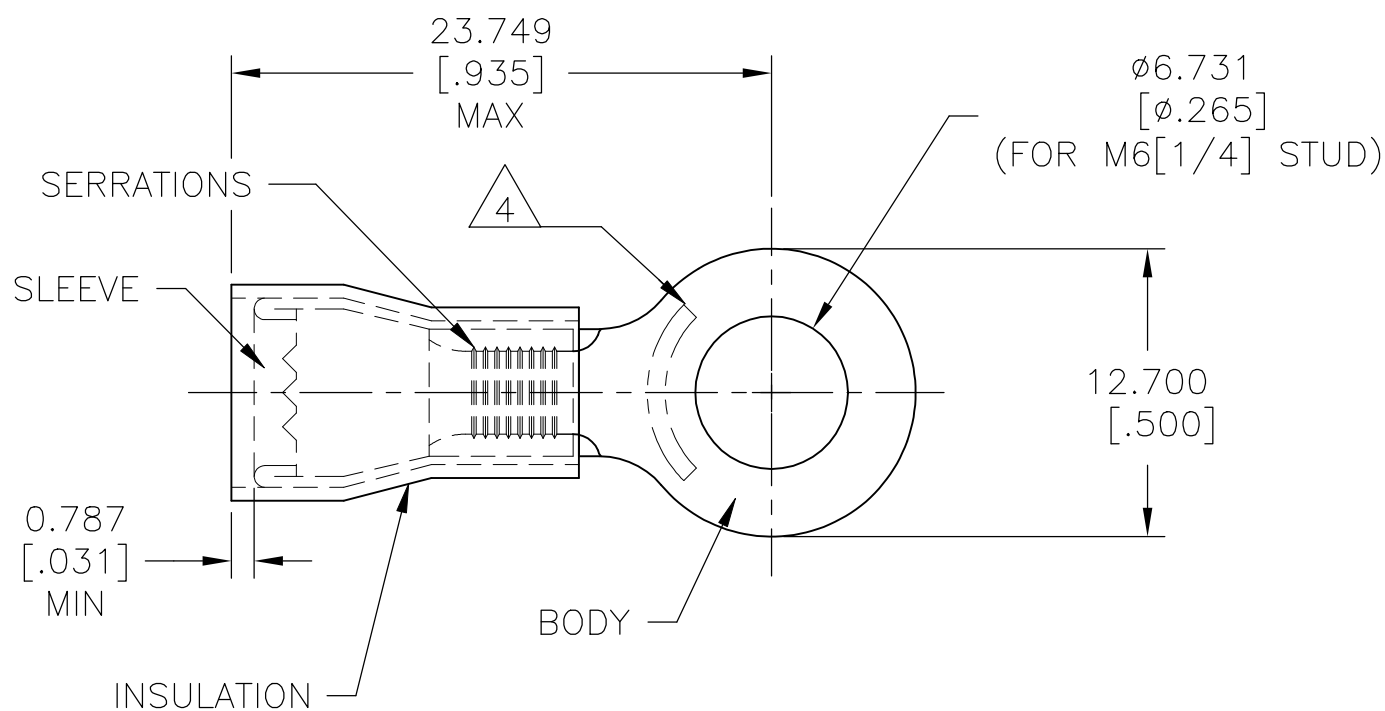

- 1 APPLIES FROM EDGE OF METAL WIRE BARREL TO CENTER OF STUD HOLE
- 2 MATERIAL:  
BODY & SLEEVE: COPPER PER ASTM B152  
INSULATION: NYLON
- 3 FINISH:  
BODY & SLEEVE: TIN PLATED PER ASTM B545  
INSULATION: COLOR - YELLOW
- 4 STAMP AMP 12-10\* APPROX AS SHOWN
- 5 FOR 3.810 TO 6.350 [.150 TO .250] INS. DIA

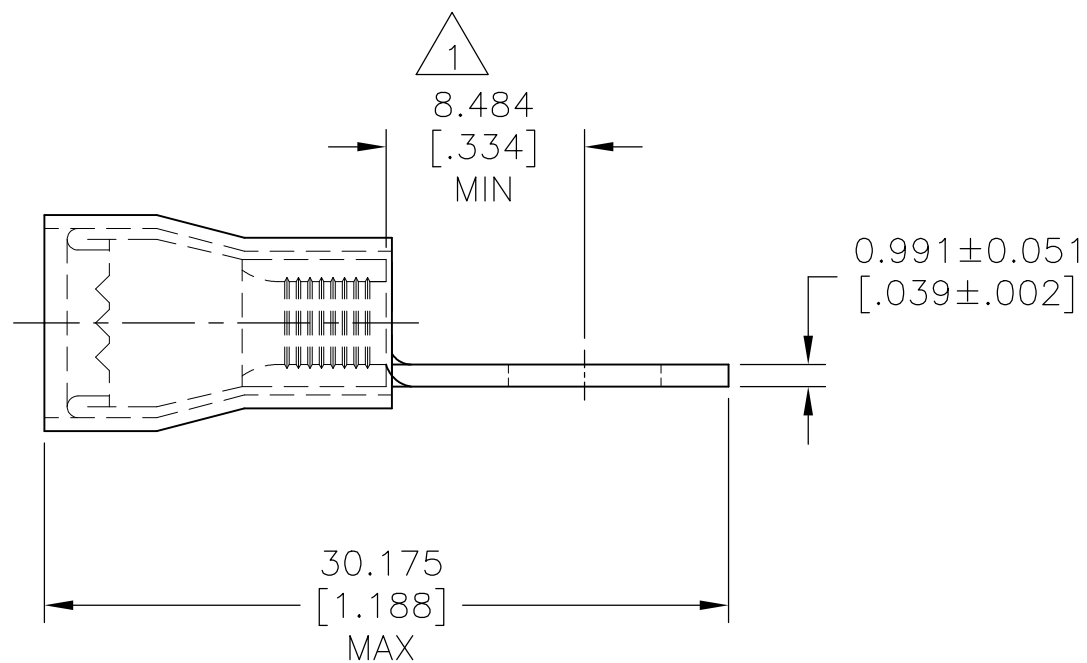

500	LOOSE PIECE	165034
QTY	PACKAGE TYPE	PART NO

AMP INCORPORATED  
CUSTOMER SERVICE SYSTEMS

THIS DRAWING IS A CONTROLLED DOCUMENT.

DWN RAVI S 07JUN2018

CHK ROHDE DANIEL F 07JUN2018

APVD ROHDE DANIEL F 07JUN2018

**STE** TE Connectivity Ltd.

FOR ADDITIONAL PRODUCT INFORMATION OR COPIES OF DRAWINGS AND TECHNICAL DOCUMENTS  
PRODUCT INFORMATION CENTER  
1-800-522-6752

MAX RECOMMENDED OPERATING TEMPERATURE:  
105°C [221°F]

DIMENSIONS:  
mm [INCHES]

TOLERANCES UNLESS OTHERWISE SPECIFIED:

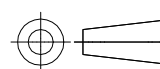

- 0 PLC ± -
- 1 PLC ± -
- 2 PLC ± -
- 3 PLC ± 0.127 [0.005]
- 4 PLC ± -
- ANGLES ± -

PRODUCT SPEC

UL 486 A-B

APPLICATION SPEC

114-2157

WEIGHT

NAME  
TERMINAL, RING TONGUE, PIDG  
WIRE SIZE: 12-10 AWG

FOR APPLICATION TOOLING INFORMATION  
TOOLING ASSISTANCE CENTER  
1-800-722-1111

WIRE CROSS SECTIONAL AREA RANGE,  
2.62-6.64mm<sup>2</sup> [5,180-13,100] CIR MILS

MATERIAL



FINISH



CUSTOMER DRAWING

SIZE A3 CAGE CODE 00779 DRAWING NO C-165034 RESTRICTED TO -

FOR ORDER ENTRY  
1-800-526-5142

SCALE N.T.S SHEET 1 OF 1 REV B1