



Programmable System Clock Chip for ATI RS/RD690 - K8™ based Systems

Recommended Application:

ATI RS/RD690 systems using AMD K8 processors & SB600 Southbridge

Output Features:

- 2 - pairs of CPU pairs
- 8 - pairs of SRC pairs
- 4 - pairs of ATIG pairs
- 1 - HyperTransport 66MHz clock seed
- 2 - 48MHz USB clock
- 3 - 14.318MHz Reference clock

Key Specifications:

- CPU outputs cycle-to-cycle jitter < 85ps
- SRC outputs cycle-to-cycle jitter < 125ps
- ATIG outputs cycle-to-cycle jitter < 125ps
- +/- 300ppm frequency accuracy on CPU, SRC & ATIG clocks

Features/Benefits:

- 3 - Programmable Clock Request pins for SRC and ATIG clocks
- ATIGCLKs are programmable for frequency
- Spread Spectrum for EMI reduction
- Outputs may be disabled via SMBus
- External crystal load capacitors for maximum frequency accuracy

Functionality

FS2	FS1	FS0	CPU MHz	HTT MHz	SRC MHz	ATIG MHz	USB MHz
0	0	0	Hi-Z	Hi-Z	100.00	100.00	48.00
0	0	1	X / 2	X / 3	100.00	100.00	48.00
0	1	0	230.00	76.67	100.00	100.00	48.00
0	1	1	240.00	80.00	100.00	100.00	48.00
1	0	0	100.00	66.66	100.00	100.00	48.00
1	0	1	133.33	66.66	100.00	100.00	48.00
1	1	0	166.67	66.66	100.00	100.00	48.00
1	1	1	200.00	66.66	100.00	100.00	48.00

Power Groups

Pin Number		Description
VDD	GND	
5	8	USB_48 outputs
14,23,28,44	15,22,29,45	SRCCLK outputs
39	38	ATIGCLK differential outputs
50	49	Analog, PLL
54	53	CPUCLK8 differential outputs
60	58	HTTCLK output
2	1	REF outputs

Pin Configuration

GNDREF	1	64	FS0/REF0
VDDREF	2	63	FS1/REF1
X1	3	62	FS2/REF2
X2	4	61	PD**
VDD48	5	60	VDDHTT
48MHz_0	6	59	HTTCLK0
48MHz_1	7	58	GNDHTT
GND48	8	57	*CLKREQA#
SMBCLK	9	56	CPUCLK8T0
SMBDAT	10	55	CPUCLK8C0
RESET_IN#	11	54	VDDCPU
SRCCLKT7	12	53	GNDCPU
SRCCLKC7	13	52	CPUCLK8T1
VDDSRC	14	51	CPUCLK8C1
GNDSRC	15	50	VDDA
SRCCLKT6	16	49	GND A
SRCCLKC6	17	48	IREF
SRCCLKT5	18	47	SRCCLKT0
SRCCLKC5	19	46	SRCCLKC0
SRCCLKT4	20	45	GNDSRC
SRCCLKC4	21	44	VDDSRC
GNDSRC	22	43	SRCCLKT1
VDDSRC	23	42	SRCCLKC1
SRCCLKT3	24	41	ATIGCLKT0
SRCCLKC3	25	40	ATIGCLKC0
SRCCLKT2	26	39	VDDATIG
SRCCLKC2	27	38	GNDATIG
VDDSRC	28	37	ATIGCLKT1
GNDSRC	29	36	ATIGCLKC1
ATIGCLKT3	30	35	ATIGCLKT2
ATIGCLKC3	31	34	ATIGCLKC2
*CLKREQB#	32	33	*CLKREQC#

ICS 951462

64-TSSOP

* Internal Pull-Up Resistor

** Internal Pull-Down Resistor

Pin Description

PIN #	PIN NAME	TYPE	DESCRIPTION
1	GNDREF	PWR	Ground pin for the REF outputs.
2	VDDREF	PWR	Ref, XTAL power supply, nominal 3.3V
3	X1	IN	Crystal input, Nominally 14.318MHz.
4	X2	OUT	Crystal output, Nominally 14.318MHz
5	VDD48	PWR	Power pin for the 48MHz output.3.3V
6	48MHz_0	OUT	48MHz clock output.
7	48MHz_1	OUT	48MHz clock output.
8	GND48	PWR	Ground pin for the 48MHz outputs
9	SMBCLK	IN	Clock pin of SMBUS circuitry, 5V tolerant
10	SMBDAT	I/O	Data pin of SMBUS circuitry, 5V tolerant
11	RESET_IN#	IN	Real time active low input. When active, SMBus is reset to power up default.
12	SRCCLKT7	OUT	True clock of differential SRC clock pair.
13	SRCCLKC7	OUT	Complement clock of differential SRC clock pair.
14	VDDSRC	PWR	Supply for SRC clocks, 3.3V nominal
15	GNDSRC	PWR	Ground pin for the SRC outputs
16	SRCCLKT6	OUT	True clock of differential SRC clock pair.
17	SRCCLKC6	OUT	Complement clock of differential SRC clock pair.
18	SRCCLKT5	OUT	True clock of differential SRC clock pair.
19	SRCCLKC5	OUT	Complement clock of differential SRC clock pair.
20	SRCCLKT4	OUT	True clock of differential SRC clock pair.
21	SRCCLKC4	OUT	Complement clock of differential SRC clock pair.
22	GNDSRC	PWR	Ground pin for the SRC outputs
23	VDDSRC	PWR	Supply for SRC clocks, 3.3V nominal
24	SRCCLKT3	OUT	True clock of differential SRC clock pair.
25	SRCCLKC3	OUT	Complement clock of differential SRC clock pair.
26	SRCCLKT2	OUT	True clock of differential SRC clock pair.
27	SRCCLKC2	OUT	Complement clock of differential SRC clock pair.
28	VDDSRC	PWR	Supply for SRC clocks, 3.3V nominal
29	GNDSRC	PWR	Ground pin for the SRC outputs
30	ATIGCLKT3	OUT	True clock of differential ATIGCLK clock pair.
31	ATIGCLKC3	OUT	Complementary clock of differential ATIGCLK clock pair.
32	*CLKREQB#	IN	Output enable for PCI Express (SRC) outputs. SMBus selects which outputs are controlled. 0 = enabled, 1 = tri-stated

Pin Description (Continued)

PIN #	PIN NAME	TYPE	DESCRIPTION
33	*CLKREQC#	IN	Output enable for PCI Express (SRC) outputs. SMBus selects which outputs are controlled. 0 = enabled, 1 = tri-stated
34	ATIGCLKC2	OUT	Complementary clock of differential ATIGCLK clock pair.
35	ATIGCLKT2	OUT	True clock of differential ATIGCLK clock pair.
36	ATIGCLKC1	OUT	Complementary clock of differential ATIGCLK clock pair.
37	ATIGCLKT1	OUT	True clock of differential ATIGCLK clock pair.
38	GNDATIG	PWR	Ground for ATIG clocks
39	VDDATIG	PWR	Power supply ATIG clocks, nominal 3.3V
40	ATIGCLKC0	OUT	Complementary clock of differential ATIGCLK clock pair.
41	ATIGCLKT0	OUT	True clock of differential ATIGCLK clock pair.
42	SRCCLKC1	OUT	Complement clock of differential push-pull SRC clock pair.
43	SRCCLKT1	OUT	True clock of differential SRC clock pair.
44	VDDSRC	PWR	Supply for SRC clocks, 3.3V nominal
45	GNDSRC	PWR	Ground pin for the SRC outputs
46	SRCCLKC0	OUT	Complement clock of differential SRC clock pair.
47	SRCCLKT0	OUT	True clock of differential SRC clock pair.
48	IREF	OUT	This pin establishes the reference current for the differential current-mode output pairs. This pin requires a fixed precision resistor tied to ground in order to establish the appropriate current. 475 ohms is the standard value.
49	GND A	PWR	Ground pin for the PLL core.
50	VDD A	PWR	3.3V power for the PLL core.
51	CPUCLK8C1	OUT	Complementary clock of differential 3.3V push-pull K8 pair.
52	CPUCLK8T1	OUT	True clock of differential 3.3V push-pull K8 pair.
53	GND CPU	PWR	Ground pin for the CPU outputs
54	VDD CPU	PWR	Supply for CPU clocks, 3.3V nominal
55	CPUCLK8C0	OUT	Complementary clock of differential 3.3V push-pull K8 pair.
56	CPUCLK8T0	OUT	True clock of differential 3.3V push-pull K8 pair.
57	*CLKREQA#	IN	Output enable for PCI Express (SRC) outputs. SMBus selects which outputs are controlled. 0 = enabled, 1 = tri-stated
58	GNDHTT	PWR	Ground pin for the HTT outputs
59	HTTCLK0	OUT	3.3V Hyper Transport output
60	VDDHTT	PWR	Supply for HTT clocks, nominal 3.3V.
61	PD**	IN	Asynchronous active high input pin used to power down the device. The internal clocks are disabled and the VCO is stopped.
62	FS2/REF2	I/O	Frequency select latch input pin / 14.318 MHz reference clock.
63	FS1/REF1	I/O	Frequency select latch input pin / 14.318 MHz reference clock.
64	FS0/REF0	I/O	Frequency select latch input pin / 14.318 MHz reference clock.

General Description

The **ICS951462** is a main clock synthesizer chip that provides all clocks required for ATI RS/RD690-based systems. An SMBus interface allows full control of the device.

Block Diagram

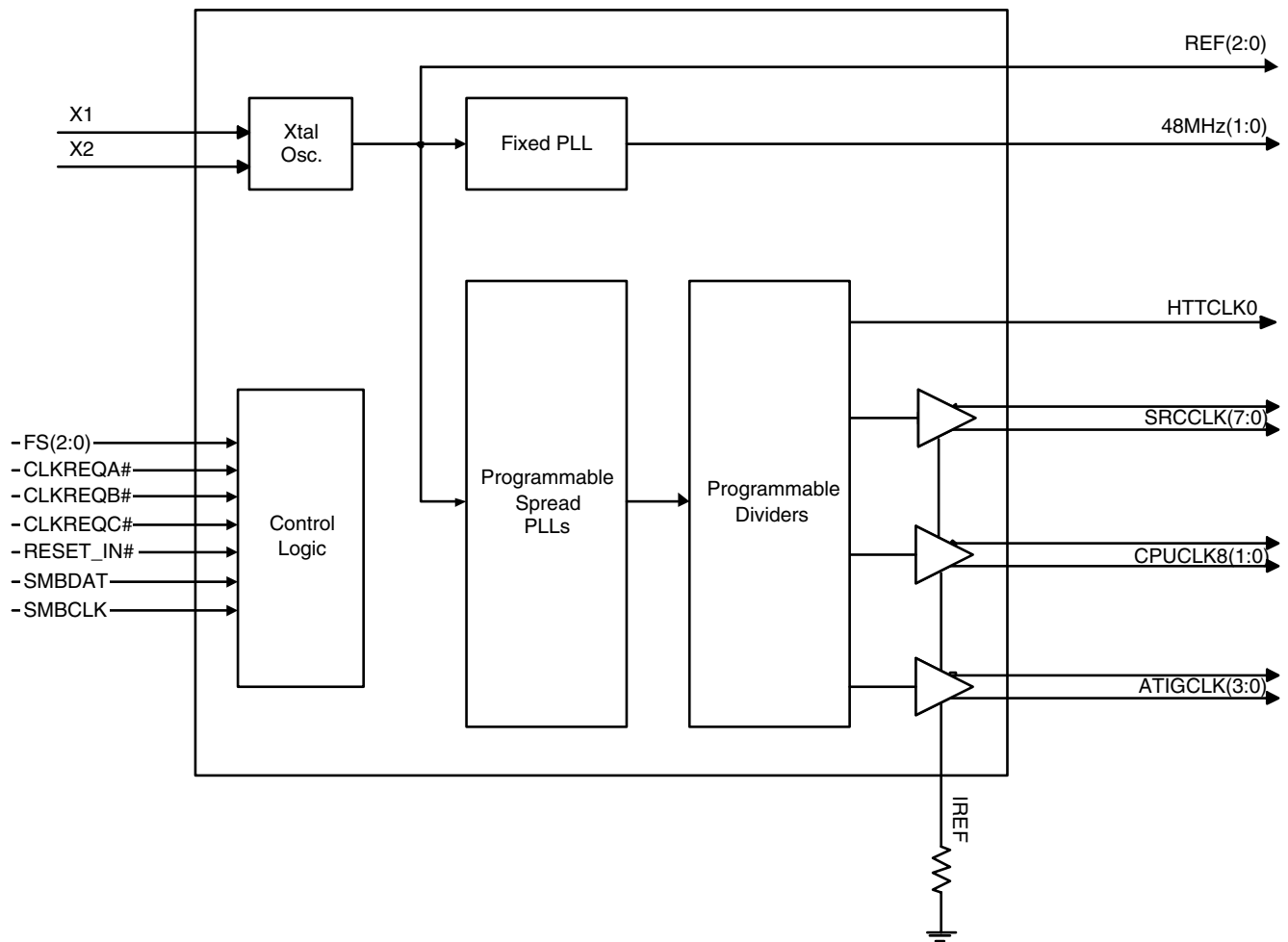

Table1: CPU and HTT Frequency Selection Table

Byte 0					CPUCLK (2:0) (MHz)	HTT (MHz)	Spread %	Overclock %
Bit4	Bit3	Bit2	Bit1	Bit0				
CPU SS_EN	CPU FS3	CPU FS2	CPU FS1	CPU FS0				
0	0	0	0	0	Hi-Z	Hi-Z	None	
0	0	0	0	1	X / 2	X / 3	None	
0	0	0	1	0	230.00	76.67	None	15%
0	0	0	1	1	240.00	80.00	None	20%
0	0	1	0	0	100.00	66.67	None	0%
0	0	1	0	1	133.33	66.67	None	
0	0	1	1	0	166.67	66.67	None	
0	0	1	1	1	200.00	66.67	None	
0	1	0	0	0	250.00	83.33	None	25%
0	1	0	0	1	260.00	86.67	None	30%
0	1	0	1	0	270.00	90.00	None	35%
0	1	0	1	1	280.00	93.33	None	40%
0	1	1	0	0	102.00	68.00	None	2%
0	1	1	0	1	136.00	68.00	None	
0	1	1	1	0	170.00	68.00	None	
0	1	1	1	1	204.00	68.00	None	
1	0	0	0	0	210.00	70.00	-0.5%	5%
1	0	0	0	1	220.00	73.33	-0.5%	10%
1	0	0	1	0	230.00	76.67	-0.5%	15%
1	0	0	1	1	240.00	80.00	-0.5%	20%
1	0	1	0	0	100.00	66.67	-0.5%	0%
1	0	1	0	1	133.33	66.67	-0.5%	
1	0	1	1	0	166.67	66.67	-0.5%	
1	0	1	1	1	200.00	66.67	-0.5%	
1	1	0	0	0	250.00	83.33	-0.5%	25%
1	1	0	0	1	260.00	86.67	-0.5%	30%
1	1	0	1	0	270.00	90.00	-0.5%	35%
1	1	0	1	1	280.00	93.33	-0.5%	40%
1	1	1	0	0	102.00	68.00	-0.5%	2%
1	1	1	0	1	136.00	68.00	-0.5%	
1	1	1	1	0	170.00	68.00	-0.5%	
1	1	1	1	1	204.00	68.00	-0.5%	

Table2: SRC Frequency Selection Table

Byte 0 Bit 5	Byte 5				SRC(7:0) (MHz)	Spread %	SRC OverClock %
	SRC SS_EN	SRC FS3	SRC FS2	SRC FS1			
0	0	0	0	0	100.00	0	0%
0	0	0	0	1	101.00	0	1%
0	0	0	1	0	102.00	0	2%
0	0	0	1	1	103.00	0	3%
0	0	1	0	0	104.00	0	4%
0	0	1	0	1	105.00	0	5%
0	0	1	1	0	106.00	0	6%
0	0	1	1	1	107.00	0	7%
0	1	0	0	0	100.00	0	0%
0	1	0	0	1	101.00	0	1%
0	1	0	1	0	102.00	0	2%
0	1	0	1	1	103.00	0	3%
0	1	1	0	0	104.00	0	4%
0	1	1	0	1	105.00	0	5%
0	1	1	1	0	106.00	0	6%
0	1	1	1	1	107.00	0	7%
1	0	0	0	0	100.00	-0.25%	0%
1	0	0	0	1	101.00	-0.25%	1%
1	0	0	1	0	102.00	-0.25%	2%
1	0	0	1	1	103.00	-0.25%	3%
1	0	1	0	0	104.00	-0.25%	4%
1	0	1	0	1	105.00	-0.25%	5%
1	0	1	1	0	106.00	-0.25%	6%
1	0	1	1	1	107.00	-0.25%	7%
1	1	0	0	0	100.00	-0.5%	0%
1	1	0	0	1	101.00	-0.5%	1%
1	1	0	1	0	102.00	-0.5%	2%
1	1	0	1	1	103.00	-0.5%	3%
1	1	1	0	0	104.00	-0.5%	4%
1	1	1	0	1	105.00	-0.5%	5%
1	1	1	1	0	106.00	-0.5%	6%
1	1	1	1	1	107.00	-0.5%	7%

Table3: ATIG Frequency Selection Table

Byte 0 Bit 6	Byte 9				ATIG(2:0) (MHz)	Spread %	ATIG OverClock %
	Bit3	Bit2	Bit1	Bit0			
ATIG SS_EN	ATIG FS3	ATIG FS2	ATIG FS1	ATIG FS0			
0	0	0	0	0	100.00	0	0%
0	0	0	0	1	105.00	0	5%
0	0	0	1	0	110.00	0	10%
0	0	0	1	1	115.00	0	15%
0	0	1	0	0	120.00	0	20%
0	0	1	0	1	125.00	0	25%
0	0	1	1	0	130.00	0	30%
0	0	1	1	1	135.00	0	35%
0	1	0	0	0	100.00	0	0%
0	1	0	0	1	105.00	0	5%
0	1	0	1	0	110.00	0	10%
0	1	0	1	1	115.00	0	15%
0	1	1	0	0	120.00	0	20%
0	1	1	0	1	125.00	0	25%
0	1	1	1	0	130.00	0	30%
0	1	1	1	1	135.00	0	35%
1	0	0	0	0	100.00	-0.25%	0%
1	0	0	0	1	105.00	-0.25%	5%
1	0	0	1	0	110.00	-0.25%	10%
1	0	0	1	1	115.00	-0.25%	15%
1	0	1	0	0	120.00	-0.25%	20%
1	0	1	0	1	125.00	-0.25%	25%
1	0	1	1	0	130.00	-0.25%	30%
1	0	1	1	1	135.00	-0.25%	35%
1	1	0	0	0	100.00	-0.5%	0%
1	1	0	0	1	105.00	-0.5%	5%
1	1	0	1	0	110.00	-0.5%	10%
1	1	0	1	1	115.00	-0.5%	15%
1	1	1	0	0	120.00	-0.5%	20%
1	1	1	0	1	125.00	-0.5%	25%
1	1	1	1	0	130.00	-0.5%	30%
1	1	1	1	1	135.00	-0.5%	35%

Table 4: CPU Divider Ratios

B19b(7:4)		Divider (3:2)							
Divider (1:0)	Bit	00		01		10		11	MSB
	00	0000	2	0100	4	1000	8	1100	16
	01	0001	3	0101	6	1001	12	1101	24
	10	0010	5	0110	10	1010	20	1110	40
	11	0011	15	0111	30	1011	60	1111	120
	LSB	Address	Div	Address		Address	Div	Address	Div

Table 5: HTT Divider Ratios

B20b(3:0)		Divider (3:2)							
Divider (1:0)	Bit	00		01		10		11	MSB
	00	0000	4	0100	8	1000	16	1100	32
	01	0001	3	0101	6	1001	12	1101	24
	10	0010	5	0110	10	1010	20	1110	40
	11	0011	15	0111	30	1011	60	1111	120
	LSB	Address	Div	Address		Address	Div	Address	Div

Table 6: ATIG Divider Ratios

B19b(3:0)		Divider (3:2)							
Divider (1:0)	Bit	00		01		10		11	MSB
	00	0000	2	0100	4	1000	8	1100	16
	01	0001	3	0101	6	1001	12	1101	24
	10	0010	5	0110	10	1010	20	1110	40
	11	0011	7	0111	14	1011	28	1111	56
	LSB	Address	Div	Address		Address	Div	Address	Div

General SMBus serial interface information for the ICS951462

How to Write:

- Controller (host) sends a start bit.
- Controller (host) sends the write address $D2_{(H)}$
- ICS clock will **acknowledge**
- Controller (host) sends the beginning byte location = N
- ICS clock will **acknowledge**
- Controller (host) sends the data byte count = X
- ICS clock will **acknowledge**
- Controller (host) starts sending **Byte N through Byte N + X - 1**
(see Note 2)
- ICS clock will **acknowledge** each byte **one at a time**
- Controller (host) sends a Stop bit

How to Read:

- Controller (host) will send start bit.
- Controller (host) sends the write address $D2_{(H)}$
- ICS clock will **acknowledge**
- Controller (host) sends the beginning byte location = N
- ICS clock will **acknowledge**
- Controller (host) will send a separate start bit.
- Controller (host) sends the read address $D3_{(H)}$
- ICS clock will **acknowledge**
- ICS clock will send the data byte count = X
- ICS clock sends **Byte N + X - 1**
- ICS clock sends **Byte 0 through byte X (if $X_{(H)}$ was written to byte 8).**
- Controller (host) will need to acknowledge each byte
- Controller (host) will send a not acknowledge bit
- Controller (host) will send a stop bit

Index Block Write Operation		
Controller (Host)		ICS (Slave/Receiver)
T	starT bit	
Slave Address $D2_{(H)}$		
WR	WRite	
		ACK
Beginning Byte = N		
		ACK
Data Byte Count = X		
		ACK
Beginning Byte N	X Byte	
○		ACK
○		○
○		○
Byte N + X - 1		○
		ACK
P	stoP bit	

Index Block Read Operation			
Controller (Host)		ICS (Slave/Receiver)	
T	starT bit		
Slave Address $D2_{(H)}$			
WR	WRite		
		ACK	
Beginning Byte = N			
		ACK	
RT	Repeat starT		
Slave Address $D3_{(H)}$			
RD	ReaD		
		ACK	
		Data Byte Count = X	
ACK			
ACK		X Byte	
			Beginning Byte N
○			○
○			○
○			○
		Byte N + X - 1	
N	Not acknowledge		
P	stoP bit		

SMBus Table: Spread Spectrum Enable and CPU Frequency Select Register

Byte 0	Pin #	Name	Control Function	Type	0	1	PWD
Bit 7	-	FS Source	Latched Input or SMBus Frequency Select	RW	Latched Inputs	SMBus	0
Bit 6	-	ATIG_SS_EN	ATIG Spread Spectrum Enable	RW	Disable	Enable	0
Bit 5	-	SRC_SS_EN	SRC Spread Spectrum Enable	RW	Disable	Enable	0
Bit 4	-	CPU_SS_EN	CPU Spread Spectrum Enable	RW	Disable	Enable	0
Bit 3	-	CPU_FS3	CPU Freq Select Bit 3	RW	See Table 1: CPU Frequency Selection Table		0
Bit 2	-	CPU_FS2	CPU Freq Select Bit 2	RW			Latch
Bit 1	-	CPU_FS1	CPU Freq Select Bit 1	RW			Latch
Bit 0	-	CPU_FS0	CPU Freq Select Bit 0	RW			Latch

Note: Each Spread Spectrum Enable bit is independent from the other.

Bit(6:4) must all set to "1" in order to enable spread for CPU, SRC and ATIG clocks.

SMBus Table: Output Control Register

Byte 1	Pin #	Name	Control Function	Type	0	1	PWD
Bit 7	7	48MHz_1	48MHz_1 Output Enable	RW	Disable	Enable	1
Bit 6	6	48MHz_0	48MHz_0 Output Enable	RW	Disable	Enable	1
Bit 5	62	REF2	REF2 Output Enable	RW	Disable	Enable	1
Bit 4	63	REF1	REF1 Output Enable	RW	Disable	Enable	1
Bit 3	64	REF0	REF0 Output Enable	RW	Disable	Enable	1
Bit 2	59	HTTCLK0	HTTCLK0 Output Enable	RW	Disable	Enable	1
Bit 1	52,51	CPUCLK1	CPUCLK1 Output Enable	RW	Disable	Enable	1
Bit 0	56,55	CPUCLK0	CPUCLK0 Output Enable	RW	Disable	Enable	1

SMBus Table: ATIGCLK and CLKREQB# Output Control Register

Byte 2	Pin #	Name	Control Function	Type	0	1	PWD
Bit 7	30,31	ATIGCLK3	ATIGCLK3 Output Enable	RW	Disable	Enable	1
Bit 6	35,34	ATIGCLK2	ATIGCLK2 Output Enable	RW	Disable	Enable	1
Bit 5	37,36	ATIGCLK1	ATIGCLK1 Output Enable	RW	Disable	Enable	1
Bit 4	41,40	ATIGCLK0	ATIGCLK0 Output Enable	RW	Disable	Enable	1
Bit 3	20,21	REQBSRC4	CLKREQB# Controls SRC4	RW	Does not control	Controls	0
Bit 2	24,25	REQBSRC3	CLKREQB# Controls SRC3	RW	Does not control	Controls	0
Bit 1	26,27	REQBSRC2	CLKREQB# Controls SRC2	RW	Does not control	Controls	0
Bit 0	30,31	REQBATIG3	CLKREQB# Controls ATIG3	RW	Does not control	Controls	0

SMBus Table: SRCCLK Output Control Register

Byte 3	Pin #	Name	Control Function	Type	0	1	PWD
Bit 7	12,13	SRCCLK7	Master Output control. Enables or disables output, regardless of CLKREQ# inputs.	RW	Disable	Enable	1
Bit 6	16,17	SRCCLK6		RW	Disable	Enable	1
Bit 5	18,19	SRCCLK5		RW	Disable	Enable	1
Bit 4	20,21	SRCCLK4		RW	Disable	Enable	1
Bit 3	24,25	SRCCLK3		RW	Disable	Enable	1
Bit 2	26,27	SRCCLK2		RW	Disable	Enable	1
Bit 1	43,42	SRCCLK1		RW	Disable	Enable	1
Bit 0	47,46	SRCCLK0		RW	Disable	Enable	1

SMBus Table: CLKREQA# and CLKREQC# Output Control Register

Byte 4	Pin #	Name	Control Function	Type	0	1	PWD
Bit 7	12,13	REQASRC7	CLKREQA# Controls SRC7	RW	Does not control	Controls	0
Bit 6	16,17	REQASRC6	CLKREQA# Controls SRC6	RW	Does not control	Controls	0
Bit 5	18,19	REQASRC5	CLKREQA# Controls SRC5	RW	Does not control	Controls	0
Bit 4	43,42	REQCSRC1	CLKREQC# Controls SRC1	RW	Does not control	Controls	0
Bit 3	35,34	REQCATIG2	CLKREQC# Controls ATIG2	RW	Does not control	Controls	0
Bit 2	37,36	REQCATIG1	CLKREQC# Controls ATIG1	RW	Does not control	Controls	0
Bit 1	41,40	REQCATIG0	CLKREQC# Controls ATIG0	RW	Does not control	Controls	0
Bit 0	47,46	REQCSRC0	CLKREQC# Controls SRC0	RW	Does not control	Controls	0

SMBus Table: CPU Stop Control and SRC Frequency Select Register

Byte 5	Pin #	Name	Control Function	Type	0	1	PWD
Bit 7			Reserved				0
Bit 6			Reserved				0
Bit 5			Reserved				0
Bit 4	SRC, ATIG	Differential Output Disable Mode	Hi-Z or Driven when disable	RW	Driven	Hi-Z	0
Bit 3	-	SRC FS3	SRC Freq Select Bit 3	RW	See Table 2: SRC Frequency Selection Table		0
Bit 2	-	SRC FS2	SRC Freq Select Bit 2	RW			0
Bit 1	-	SRC FS1	SRC Freq Select Bit 1	RW			0
Bit 0	-	SRC FS0	SRC Freq Select Bit 0	RW			0

SMBus Table: Device ID Register

Byte 6	Pin #	Name	Control Function	Type	0	1	PWD
Bit 7	-	Device ID7 (MSB)	DEVICE ID	R	-	-	0
Bit 6	-	Device ID6		R	-	-	1
Bit 5	-	Device ID5		R	-	-	1
Bit 4	-	Device ID4		R	-	-	0
Bit 3	-	Device ID3		R	-	-	0
Bit 2	-	Device ID2		R	-	-	0
Bit 1	-	Device ID1		R	-	-	1
Bit 0	-	Device ID0 (LSB)		R	-	-	0

SMBus Table: Revision and Vendor ID Register

Byte 7	Pin #	Name	Control Function	Type	0	1	PWD
Bit 7	-	RID3	REVISION ID	R	-	-	0
Bit 6	-	RID2		R	-	-	0
Bit 5	-	RID1		R	-	-	0
Bit 4	-	RID0		R	-	-	1
Bit 3	-	VID3	VENDOR ID	R	-	-	0
Bit 2	-	VID2		R	-	-	0
Bit 1	-	VID1		R	-	-	0
Bit 0	-	VID0		R	-	-	1

SMBus Table: Byte Count Register

Byte 8	Pin #	Name	Control Function	Type	0	1	PWD
Bit 7	-	BC7	Byte Count Programming b(7:0)	RW	Writing to this register will configure how many bytes will be read back, default is 9 bytes.		0
Bit 6	-	BC6		RW			0
Bit 5	-	BC5		RW			0
Bit 4	-	BC4		RW			0
Bit 3	-	BC3		RW			1
Bit 2	-	BC2		RW			0
Bit 1	-	BC1		RW			0
Bit 0	-	BC0		RW			1

SMBus Table: REF2, 48MHz Output Strength Control and ATIG Frequency Select Register

Byte 9	Pin #	Name	Control Function	Type	0	1	PWD
Bit 7	62	REF2Str	REF2 Strength Control	RW	1X	2X	1
Bit 6	7	48MHz_1Str	48MHz_1 Strength Control	RW	1X	2X	1
Bit 5	6	48MHz_0Str	48MHz_0 Strength Control	RW	1X	2X	1
Bit 4	Reserved						0
Bit 3	-	ATIG FS3	ATIG Freq Select Bit 3	RW	See Table 3: ATIG Frequency Selection Table		0
Bit 2	-	ATIG FS2	ATIG Freq Select Bit 2	RW			0
Bit 1	-	ATIG FS1	ATIG Freq Select Bit 1	RW			0
Bit 0	-	ATIG FS0	ATIG Freq Select Bit 0	RW			0

SMBus Table: PLLs M/N Programming Enable and REF1, REF0 Output Strength Control Register

Byte 10	Pin #	Name	Control Function	Type	0	1	PWD
Bit 7	-	M/N_EN	PLLs M/N Programming Enable	RW	Disable	Enable	0
Bit 6	63	REF1Str	REF1 Strength Control	RW	1X	2X	1
Bit 5	64	REF0Str	REF0 Strength Control	RW	1X	2X	1
Bit 4	Reserved						0
Bit 3	Reserved						0
Bit 2	Reserved						0
Bit 1	Reserved						0
Bit 0	Reserved						0

SMBus Table: CPU PLL VCO Frequency Control Register

Byte 11	Pin #	Name	Control Function	Type	0	1	PWD
Bit 7	-	N Div8	N Divider Prog bit 8	RW	The decimal representation of M and N Divider in Byte 11 and 12 will configure the VCO frequency. Default at power up = latch-in or Byte 0 Rom table. VCO Frequency = $14.318 \times [\text{NDiv}(9:0)+8] / [\text{MDiv}(5:0)+2]$		X
Bit 6	-	N Div 9	N Divider Prog bit 9	RW			X
Bit 5	-	M Div5	M Divider Programming bits	RW			X
Bit 4	-	M Div4		RW			X
Bit 3	-	M Div3		RW			X
Bit 2	-	M Div2		RW			X
Bit 1	-	M Div1		RW			X
Bit 0	-	M Div0		RW			X

SMBus Table: CPU PLL VCO Frequency Control Register

Byte 12	Pin #	Name	Control Function	Type	0	1	PWD
Bit 7	-	N Div7	N Divider Programming b(7:0)	RW	The decimal representation of M and N Divider in Byte 11 and 12 will configure the VCO frequency. Default at power up = latch-in or Byte 0 Rom table. VCO Frequency = $14.318 \times [\text{NDiv}(9:0)+8] / [\text{MDiv}(5:0)+2]$		X
Bit 6	-	N Div6		RW			X
Bit 5	-	N Div5		RW			X
Bit 4	-	N Div4		RW			X
Bit 3	-	N Div3		RW			X
Bit 2	-	N Div2		RW			X
Bit 1	-	N Div1		RW			X
Bit 0	-	N Div0		RW			X

SMBus Table: CPU PLL Spread Spectrum Control Register

Byte 13	Pin #	Name	Control Function	Type	0	1	PWD
Bit 7	-	SSP7	Spread Spectrum Programming b(7:0)	RW	These Spread Spectrum bits in Byte 13 and 14 will program the spread percentage. It is recommended to use ICS Spread % table for spread programming.		X
Bit 6	-	SSP6		RW			X
Bit 5	-	SSP5		RW			X
Bit 4	-	SSP4		RW			X
Bit 3	-	SSP3		RW			X
Bit 2	-	SSP2		RW			X
Bit 1	-	SSP1		RW			X
Bit 0	-	SSP0		RW			X

SMBus Table: CPU PLL Spread Spectrum Control Register

Byte 14	Pin #	Name	Control Function	Type	0	1	PWD
Bit 7	-	-	Reserved	-	-	-	0
Bit 6	-	SSP14	Spread Spectrum Programming b(14:8)	RW	These Spread Spectrum bits in Byte 13 and 14 will program the spread percentage. It is recommended to use ICS Spread % table for spread programming.		X
Bit 5	-	SSP13		RW			X
Bit 4	-	SSP12		RW			X
Bit 3	-	SSP11		RW			X
Bit 2	-	SSP10		RW			X
Bit 1	-	SSP9		RW			X
Bit 0	-	SSP8		RW			X

SMBus Table: ATIG PLL VCO Frequency Control Register

Byte 15	Pin #	Name	Control Function	Type	0	1	PWD
Bit 7	-	N Div8	N Divider Prog bit 8	RW	The decimal representation of M and N Divier in Byte 17 and 18 will configure the VCO frequency. Default at power up = Byte 0 Rom table. VCO Frequency = 14.318 x [NDiv(9:0)+8] / [MDiv(5:0)+2]		X
Bit 6	-	N Div9	N Divider Prog bit 9	RW			X
Bit 5	-	M Div5	M Divider Programming bits	RW			X
Bit 4	-	M Div4		RW			X
Bit 3	-	M Div3		RW			X
Bit 2	-	M Div2		RW			X
Bit 1	-	M Div1		RW			X
Bit 0	-	M Div0		RW			X

SMBus Table: ATIG PLL VCO Frequency Control Register

Byte 16	Pin #	Name	Control Function	Type	0	1	PWD
Bit 7	-	N Div7	N Divider Programming b(7:0)	RW	The decimal representation of M and N Divier in Byte 17 and 18 will configure the VCO frequency. Default at power up = Byte 0 Rom table. VCO Frequency = 14.318 x [NDiv(9:0)+8] / [MDiv(5:0)+2]		X
Bit 6	-	N Div6		RW			X
Bit 5	-	N Div5		RW			X
Bit 4	-	N Div4		RW			X
Bit 3	-	N Div3		RW			X
Bit 2	-	N Div2		RW			X
Bit 1	-	N Div1		RW			X
Bit 0	-	N Div0		RW			X

SMBus Table: ATIG PLL Spread Spectrum Control Register

Byte 17	Pin #	Name	Control Function	Type	0	1	PWD
Bit 7	-	SSP7	Spread Spectrum Programming b(7:0)	RW	These Spread Spectrum bits in Byte 19 and 20 will program the spread percentage. It is recommended to use ICS Spread % table for spread programming.		X
Bit 6	-	SSP6		RW			X
Bit 5	-	SSP5		RW			X
Bit 4	-	SSP4		RW			X
Bit 3	-	SSP3		RW			X
Bit 2	-	SSP2		RW			X
Bit 1	-	SSP1		RW			X
Bit 0	-	SSP0		RW			X

SMBus Table: ATIG PLL Spread Spectrum Control Register

Byte 18	Pin #	Name	Control Function	Type	0	1	PWD
Bit 7		Reserved					0
Bit 6	-	SSP14	Spread Spectrum Programming b(14:8)	RW	These Spread Spectrum bits in Byte 19 and 20 will program the spread percentage. It is recommended to use ICS Spread % table for spread programming.		X
Bit 5	-	SSP13		RW			X
Bit 4	-	SSP12		RW			X
Bit 3	-	SSP11		RW			X
Bit 2	-	SSP10		RW			X
Bit 1	-	SSP9		RW			X
Bit 0	-	SSP8		RW			X

SMBus Table: CPU and ATIG Divider Ratio Programming Bits Select Register

Byte 19	Pin #	Name	Control Function	Type	0	1	PWD
Bit 7	-	CPU_Div3	CPU_Divider Ratio Programming Bits	RW	See Table 4: CPU Divider Ratios		X
Bit 6	-	CPU_Div2		RW			X
Bit 5	-	CPU_Div1		RW			X
Bit 4	-	CPU_Div0		RW			X
Bit 3	-	ATIG_Div3	ATIG_Divider Ratio Programming Bits	RW	See Table 5: ATIG Divider Ratios		X
Bit 2	-	ATIG_Div2		RW			X
Bit 1	-	ATIG_Div1		RW			X
Bit 0	-	ATIG_Div0		RW			X

SMBus Table: HTT Divider Ratio Programming Bits Select Register

Byte 20	Pin #	Name	Control Function	Type	0	1	PWD
Bit 7		Reserved					0
Bit 6		Reserved					0
Bit 5		Reserved					0
Bit 4		Reserved					0
Bit 3	-	HTT_Div3	HTT_Divider Ratio Programming Bits	RW	See Table 6: HTT Divider Ratios		X
Bit 2	-	HTT_Div2		RW			X
Bit 1	-	HTT_Div1		RW			X
Bit 0	-	HTT_Div0		RW			X

Absolute Maximum Rating (Above which useful life may be impaired)

PARAMETER	SYMBOL	CONDITIONS	MIN	TYP	MAX	UNITS	Notes
3.3V Core Supply Voltage	VDD_A	-			V _{DD} + 0.5V	V	1
3.3V Logic Input Supply Voltage	VDD_In	-	GND - 0.5		V _{DD} + 0.5V	V	1
Storage Temperature	Ts	-	-65		150	°C	1
Ambient Operating Temp	Tambient	-	0		70	°C	1
Max Junction Temp	T _J	V _{DD} MAX, 70°C			130	°C	1
Case Temperature	Tcase	-			115	°C	1
Input ESD protection HBM	ESD prot	-	2000			V	1

¹Guaranteed by design and characterization, not 100% tested in production.

Electrical Characteristics - Input/Supply/Common Output Parameters

PARAMETER	SYMBOL	CONDITIONS*	MIN	TYP	MAX	UNITS	Notes
Input High Voltage	V _{IH}	3.3 V +/-5%	2		V _{DD} + 0.3	V	1
Input Low Voltage	V _{IL}	3.3 V +/-5%	V _{SS} - 0.3		0.8	V	1
Input High Current	I _{IH}	V _{IN} = V _{DD}	-5		5	uA	1
Input Low Current	I _{IL1}	V _{IN} = 0 V; Inputs with no pull-up resistors	-5			uA	1
	I _{IL2}	V _{IN} = 0 V; Inputs with pull-up resistors	-200			uA	1
Low Threshold Input-High Voltage	V _{IH_FS}	3.3 V +/-5%	0.7		V _{DD} + 0.3	V	1
Low Threshold Input-Low Voltage	V _{IL_FS}	3.3 V +/-5%	V _{SS} - 0.3		0.35	V	1
Operating Current	I _{DD3.3OP}	all outputs driven			400	mA	1
Powerdown Current	I _{DD3.3PD}	all diff pairs driven			70	mA	1
		all differential pairs tri-stated			12	mA	1
Input Frequency	F _i	V _{DD} = 3.3 V		14.31818		MHz	2
Pin Inductance	L _{pin}				7	nH	1
Input Capacitance	C _{IN}	Logic Inputs			5	pF	1
	C _{OUT}	Output pin capacitance			6	pF	1
	C _{INX}	X1 & X2 pins			5	pF	1
Clk Stabilization	T _{STAB}	From VDD Power-Up or de-assertion of PD to 1st clock			1.8	ms	1
Modulation Frequency		Triangular Modulation	30		33	kHz	1
Tdrive_PD		CPU output enable after PD de-assertion			300	us	1
Tfall_PD		PD fall time of			5	ns	1
Trise_PD		PD rise time of			5	ns	1
SMBus Voltage	V _{DD}		2.7		5.5	V	1
Low-level Output Voltage	V _{OL}	@ I _{PULLUP}			0.4	V	1
Current sinking at V _{OL} = 0.4 V	I _{PULLUP}		4			mA	1
SMBCLK/SMBDAT Clock/Data Rise Time	T _{RI2C}	(Max VIL - 0.15) to (Min VIH + 0.15)			1000	ns	1
SMBCLK/SMBDAT Clock/Data Fall Time	T _{FI2C}	(Min VIH + 0.15) to (Max VIL - 0.15)			300	ns	1

*TA = 0 - 70°C; Supply Voltage VDD = 3.3 V +/-5%

¹Guaranteed by design and characterization, not 100% tested in production.

² Input frequency should be measured at the REF pin and tuned to ideal 14.31818MHz to meet ppm frequency accuracy on PLL outputs.

Electrical Characteristics - K8 Push Pull Differential Pair

$T_A = 0 - 70^\circ\text{C}$; $V_{DD} = 3.3\text{ V} \pm 5\%$; $C_L = \text{AMD64 Processor Test Load}$

PARAMETER	SYMBOL	CONDITIONS	MIN	TYP	MAX	UNITS	NOTES
Rising Edge Rate	$\delta V/\delta t$	Measured at the AMD64 processor's test load. 0 V +/- 400 mV (differential measurement)	2		10	V/ns	1
Falling Edge Rate	$\delta V/\delta t$		2		10	V/ns	1
Differential Voltage	V_{DIFF}	Measured at the AMD64 processor's test load. (single-ended measurement)	0.4	1.25	2.3	V	1
Change in V_{DIFF_DC} Magnitude	ΔV_{DIFF}		-150		150	mV	1
Common Mode Voltage	V_{CM}		1.05	1.25	1.45	V	1
Change in Common Mode Voltage	ΔV_{CM}		-200		200	mV	1
Jitter, Cycle to cycle	$t_{jyc-cyc}$	Measurement from differential waveform. Maximum difference of cycle time between 2 adjacent cycles.	0	50	85	ps	1
Jitter, Accumulated	t_{ja}	Measured using the JIT2 software package with a Tek 7404 scope. TIE (Time Interval Error) measurement technique: Sample resolution = 50 ps, Sample Duration = 10 μs	-1000		1000		1,2,3
Duty Cycle	d_{I3}	Measurement from differential waveform	45		53	%	1
Output Impedance	R_{ON}	Average value during switching transition. Used for determining series termination value.	15	35	55	Ω	1
Group Skew	$t_{src-skew}$	Measurement from differential waveform			50	ps	1

¹Guaranteed by design and characterization, not 100% tested in production.

²All accumulated jitter specifications are guaranteed assuming that REF is at 14.31818MHz

³Spread Spectrum is off

Electrical Characteristics - HTTCLK Clock

PARAMETER	SYMBOL	CONDITIONS	MIN	TYP	MAX	UNITS	Notes
Long Accuracy	ppm	see Tperiod min-max values	-300		300	ppm	1,2
PCI33 Clock period	T _{period}	33.33MHz output nominal	29.9910		30.0090	ns	2
		33.33MHz output spread	29.9910		30.1598	ns	2
HTT66 Clock period	T _{period}	66.67MHz output nominal	14.9955		15.0045	ns	2
		66.67MHz output spread	14.9955		15.0799	ns	2
Output High Voltage	V _{OH}	I _{OH} = -1 mA	2.4			V	1
Output Low Voltage	V _{OL}	I _{OL} = 1 mA			0.55	V	1
Output High Current	I _{OH}	V _{OH} @ MIN = 1.0 V	-33			mA	1
		V _{OH} @ MAX = 3.135 V			-33	mA	1
Output Low Current	I _{OL}	V _{OL} @ MIN = 1.95 V	30			mA	1
		V _{OL} @ MAX = 0.4 V			38	mA	1
Edge Rate	ΔV/Δt	Rising edge rate	1		4	V/ns	1
Edge Rate	ΔV/Δt	Falling edge rate	1		4	V/ns	1
Rise Time	t _{r1}	V _{OL} = 0.4 V, V _{OH} = 2.4 V	0.5		2	ns	1
Fall Time	t _{f1}	V _{OH} = 2.4 V, V _{OL} = 0.4 V	0.5		2	ns	1
Duty Cycle	d _{t1}	V _T = 1.5 V	45		55	%	1
Jitter, Cycle to cycle	t _{jyc-cyc}	V _T = 1.5 V			180	ps	1

*T_A = 0 - 70°C; VDD=3.3V +/-5%; C_L = 30 pF (unless otherwise specified)

¹Guaranteed by design and characterization, not 100% tested in production.

²All Long Term Accuracy and Clock Period specifications are guaranteed with the assumption that REF is at 14.31818MHz

Electrical Characteristics - SRC/ATIG 0.7V Current Mode Differential Pair

PARAMETER	SYMBOL	CONDITIONS*	MIN	TYP	MAX	UNITS	Notes
Current Source Output Impedance	Z _o	V _O = V _x	3000			Ω	1
Voltage High	VHigh	Statistical measurement on single ended signal	660		850	mV	1,3
Voltage Low	VLow		-150		150	mV	1,3
Max Voltage	Vovs	Measurement on single ended signal using absolute value.			1150	mV	1
Min Voltage	Vuds		-300			mV	1
Crossing Voltage (abs)	Vx(abs)		250		550	mV	1
Crossing Voltage (var)	d-Vx	Variation of crossing over all edges			140	mV	1
Long Accuracy	ppm	see Tperiod min-max values	-300		300	ppm	1,2
Average period	Tperiod	100.00MHz nominal	9.9970		10.0030	ns	2
		100.00MHz spread	9.9970		10.0533	ns	2
Absolute min period	Tabmin	100.00MHz nominal/spread	9.8720			ns	1,2
Rise Time	t _r	V _{OL} = 0.175V, V _{OH} = 0.525V	175		700	ps	1
Fall Time	t _f	V _{OH} = 0.525V V _{OL} = 0.175V	175		700	ps	1
Rise Time Variation	d-t _r	V _{OL} = 0.175V, V _{OH} = 0.525V			125	ps	1
Fall Time Variation	d-t _f	V _{OH} = 0.525V V _{OL} = 0.175V			125	ps	1
Duty Cycle	d _{t3}	Measurement from differential waveform	45		55	%	1
Skew	t _{sk3}	V _T = 50%			100	ps	1
Jitter, Cycle to cycle	t _{jyc-cyc}	Measurement from differential waveform			125	ps	1

*T_A = 0 - 70°C; V_{DD} = 3.3 V +/-5%; C_L = 2pF, R_S = 33.2Ω, R_P = 49.9Ω, I_{REF} = 475Ω

¹Guaranteed by design and characterization, not 100% tested in production.

²All Long Term Accuracy and Clock Period specifications are guaranteed assuming that REFOUT is at 14.31818MHz

³I_{REF} = V_{DD}/(3xR_P). For R_P = 475Ω (1%), I_{REF} = 2.32mA. I_{OH} = 6 x I_{REF} and V_{OH} = 0.7V @ Z_O = 50Ω.

Electrical Characteristics - USB - 48MHz

PARAMETER	SYMBOL	CONDITIONS*	MIN	TYP	MAX	UNITS	NOTES
Long Accuracy	ppm	see Tperiod min-max values	-100		100	ppm	1,2
Clock period	T_{period}	48.00MHz output nominal	20.8229		20.8344	ns	2
Clock Low Time	T_{low}	Measure from < 0.6V	9.3750		11.4580	ns	2
Clock High Time	T_{high}	Measure from > 2.0V	9.3750		11.4580	ns	2
Output High Voltage	V_{OH}	$I_{\text{OH}} = -1 \text{ mA}$	2.4			V	1
Output Low Voltage	V_{OL}	$I_{\text{OL}} = 1 \text{ mA}$			0.55	V	1
Output High Current	I_{OH}	$V_{\text{OH}} @ \text{MIN} = 1.0 \text{ V}$	-33			mA	1
		$V_{\text{OH}} @ \text{MAX} = 3.135 \text{ V}$			-33	mA	1
Output Low Current	I_{OL}	$V_{\text{OL}} @ \text{MIN} = 1.95 \text{ V}$	30			mA	1
		$V_{\text{OL}} @ \text{MAX} = 0.4 \text{ V}$			38	mA	1
Rise Time	$t_{\text{r USB}}$	$V_{\text{OL}} = 0.4 \text{ V}, V_{\text{OH}} = 2.4 \text{ V}$	0.5		1.5	ns	1
Fall Time	$t_{\text{f USB}}$	$V_{\text{OH}} = 2.4 \text{ V}, V_{\text{OL}} = 0.4 \text{ V}$	0.5		1.5	ns	1
Duty Cycle	d_{t1}	$V_{\text{T}} = 1.5 \text{ V}$	45		55	%	1
Group Skew	t_{skew}	$V_{\text{T}} = 1.5 \text{ V}$			100	ps	1
Jitter, Cycle to cycle	$t_{\text{jyc-cyc}}$	$V_{\text{T}} = 1.5 \text{ V}$			130	ps	1,2

*TA = 0 - 70°C; Supply Voltage VDD = 3.3 V +/-5%, CL = 5 pF with Rs = 22Ω (unless otherwise specified)

¹Guaranteed by design and characterization, not 100% tested in production.

²ICS recommended and/or chipset vendor layout guidelines must be followed to meet this specification

Electrical Characteristics - REF-14.318MHz

PARAMETER	SYMBOL	CONDITIONS	MIN	TYP	MAX	UNITS	Notes
Long Accuracy	ppm	see Tperiod min-max values	-300		300	ppm	1,2
Clock period	T_{period}	14.318MHz output nominal	69.8270		69.8550	ns	2
Clock Low Time	T_{low}	Measure from < 0.6V	30.9290		37.9130	ns	2
Clock High Time	T_{high}	Measure from > 2.0V	30.9290		37.9130	ns	2
Output High Voltage	V_{OH}	$I_{\text{OH}} = -1 \text{ mA}$	2.4			V	1
Output Low Voltage	V_{OL}	$I_{\text{OL}} = 1 \text{ mA}$			0.4	V	1
Output High Current	I_{OH}	$V_{\text{OH}} @ \text{MIN} = 1.0 \text{ V},$ $V_{\text{OH}} @ \text{MAX} = 3.135 \text{ V}$	-29		-23	mA	1
		$V_{\text{OL}} @ \text{MIN} = 1.95 \text{ V},$ $V_{\text{OL}} @ \text{MAX} = 0.4 \text{ V}$	29		27	mA	1
Rise Time	t_{r1}	$V_{\text{OL}} = 0.4 \text{ V}, V_{\text{OH}} = 2.4 \text{ V}$			1.5	ns	1
Fall Time	t_{f1}	$V_{\text{OH}} = 2.4 \text{ V}, V_{\text{OL}} = 0.4 \text{ V}$			1.5	ns	1
Skew	t_{sk1}	$V_{\text{T}} = 1.5 \text{ V}$			100	ps	1
Duty Cycle	d_{t1}	$V_{\text{T}} = 1.5 \text{ V}$	44	53	56	%	1
Jitter	$t_{\text{jyc-cyc}}$	$V_{\text{T}} = 1.5 \text{ V}$		200	300	ps	1

*TA = 0 - 70°C; Supply Voltage VDD = 3.3 V +/-5%, CL = 5 pF with Rs = 22Ω (unless otherwise specified)

¹Guaranteed by design and characterization, not 100% tested in production.

²All Long Term Accuracy and Clock Period specifications are guaranteed assuming that REFOUT is at 14.31818MHz

RESET_IN# - Assertion (transition from '1' to '0')

Asserting RESET_IN pin stops all the outputs including CPU, SRC, ATIG, PCI and USB with the REF[2:0] running. The pin is a Schmitt trigger input with debouncing. After it is triggered, REF clocks will wait for two clock cycle to ensure the RESET_IN is asserted. Then, it will take 3 μ s for the clocks to stop without glitches. The clock chip will be power down and re-power up, and SMBus will be reloaded. It will take no more than 2.5mS for the clocks to come out with correct frequencies and no glitches.

**** Deassertion of RESET_IN# (transition from '0' to '1') has NO effect on the clocks.**

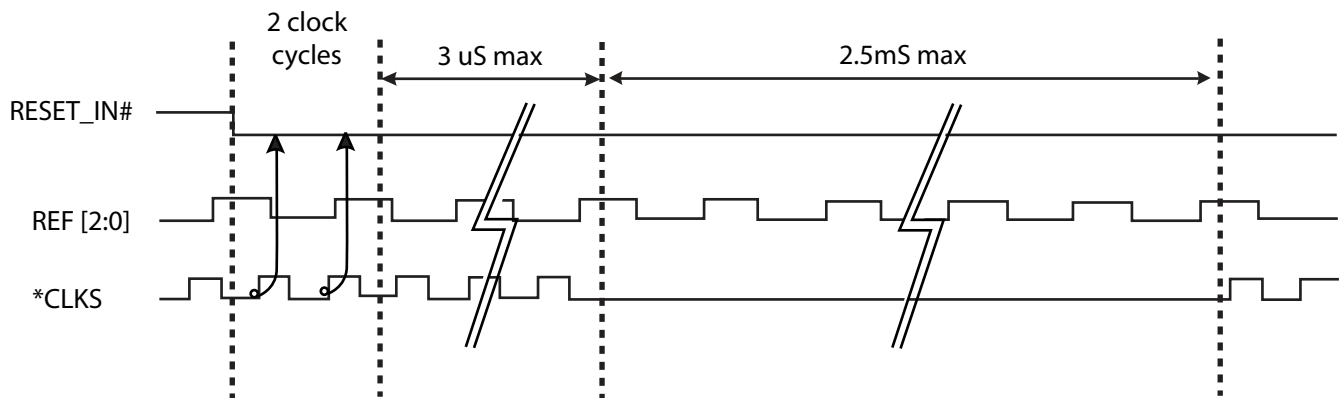

SRC Routing Information

SRC Reference Clock			
Common Recommendations for Differential Routing	Dimension or Value	Unit	Figure
L1 length, Route as non-coupled 50 ohm trace.	0.5 max	inch	2, 3
L2 length, Route as non-coupled 50 ohm trace.	0.2 max	inch	2, 3
L3 length, Route as non-coupled 50 ohm trace.	0.2 max	inch	2, 3
R_s	33	ohm	2, 3
R_t	49.9	ohm	2, 3

Down Device Differential Routing	Dimension or Value	Unit	Figure
L4 length, Route as coupled microstrip 100 ohm differential trace.	2 min to 16 max	inch	2
L4 length, Route as coupled stripline 100 ohm differential trace.	1.8 min to 14.4 max	inch	2

Differential Routing to PCI Express Connector	Dimension or Value	Unit	Figure
L4 length, Route as coupled microstrip 100 ohm differential trace.	0.25 to 14 max	inch	3
L4 length, Route as coupled stripline 100 ohm differential trace.	0.225 min to 12.6 max	inch	3

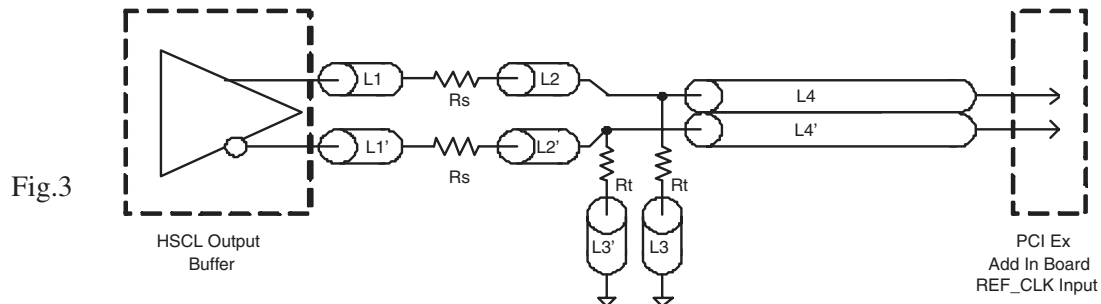
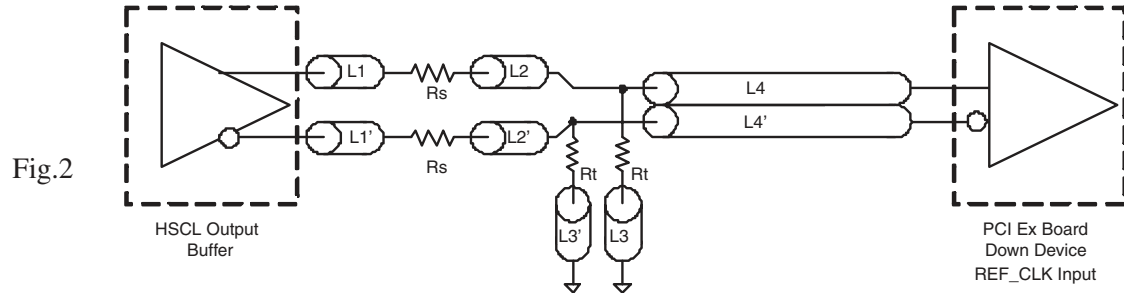
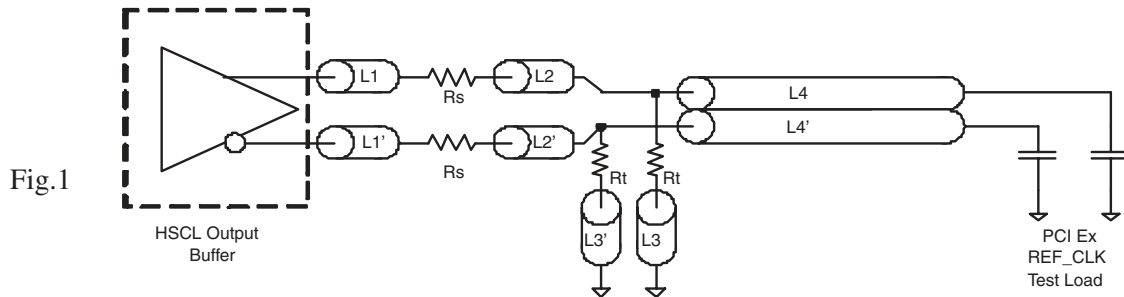

Shared Pin Operation - Input/Output Pins

The I/O pins designated by (input/output) on the **ICS951462** serve as dual signal functions to the device. During initial power-up, they act as input pins. The logic level (voltage) that is present on these pins at this time is read and stored into a 5-bit internal data latch. At the end of Power-On reset, (see AC characteristics for timing values), the device changes the mode of operations for these pins to an output function. In this mode the pins produce the specified buffered clocks to external loads.

To program (load) the internal configuration register for these pins, a resistor is connected to either the VDD (logic 1) power supply or the GND (logic 0) voltage potential. A 10 Kiloohm (10K) resistor is used to provide both the solid CMOS programming voltage needed during the power-up programming period and to provide an insignificant load on the output clock during the subsequent operating period. Figure 1 shows a means of implementing this function when a switch or 2 pin header is used. With no jumper is installed

the pin will be pulled high. With the jumper in place the pin will be pulled low. If programmability is not necessary, than only a single resistor is necessary. The programming resistors should be located close to the series termination resistor to minimize the current loop area. It is more important to locate the series termination resistor close to the driver than the programming resistor.

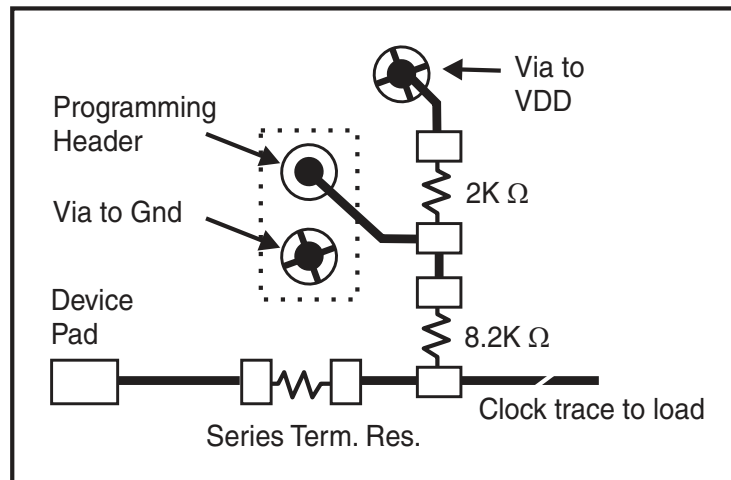
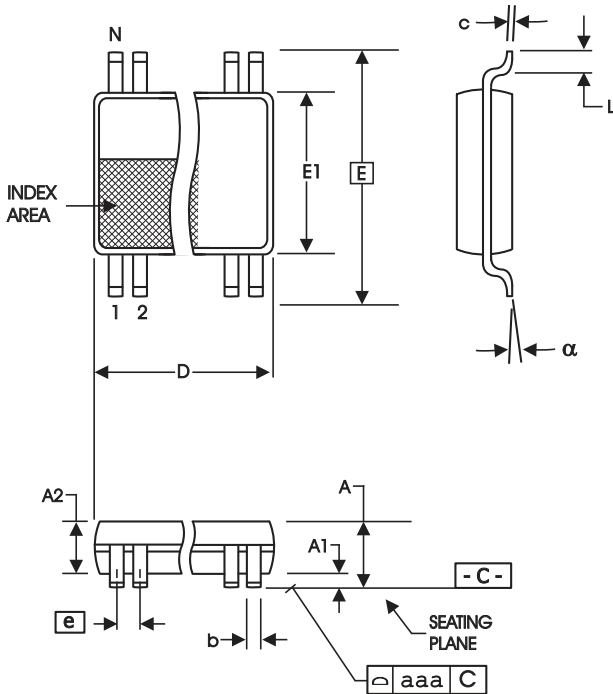

Fig. 1



6.10 mm. Body, 0.50 mm. Pitch TSSOP
(240 mil) (20 mil)

SYMBOL	In Millimeters COMMON DIMENSIONS		In Inches COMMON DIMENSIONS	
	MIN	MAX	MIN	MAX
A	--	1.20	--	.047
A1	0.05	0.15	.002	.006
A2	0.80	1.05	.032	.041
b	0.17	0.27	.007	.011
c	0.09	0.20	.0035	.008
D	SEE VARIATIONS		SEE VARIATIONS	
E	8.10 BASIC		0.319 BASIC	
E1	6.00	6.20	.236	.244
e	0.50 BASIC		0.020 BASIC	
L	0.45	0.75	.018	.030
N	SEE VARIATIONS		SEE VARIATIONS	
alpha	0°	8°	0°	8°
aaa	--	0.10	--	.004

VARIATIONS

N	D mm.		D (inch)	
	MIN	MAX	MIN	MAX
64	16.90	17.10	.665	.673

Reference Doc.: JEDEC Publication 95, MO-153

10-0039

Ordering Information

951462yGLFT

Example:

XXXX y G LFT

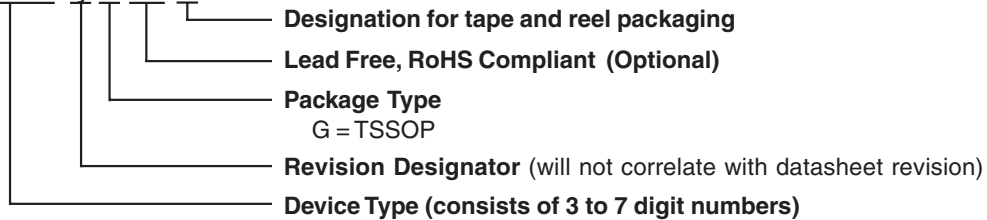

Revision History

Rev.	Issue Date	Description	Page #
0.0	4/7/2005	Initial Release	-
0.1	4/15/2005	Added Timing Diagram	19
0.2	6/6/2005	1. SMBus Byte 5 bits[6:5] are changed from CPU_STOP Enable to RESERVED. 2. Updated LF Ordering Information from "Annealed Lead Free" to "RoHS Compliant".	11, 22
0.3	6/8/2005	Updated Timing Diagram.	19
0.4	9/9/2005	1. Updated all description: Changed RS680 to RS580. 2. Updated Pin Description: Pin 11 and 57. 3. Updated Block Diagram: Took out CPU_STOP#. 4. Updated Electrical Characteristics: i. Input/Supply/Common Output Parameters: Took out Operating Supply Current. ii. USB: Updated Rise and Fall Time. iii. REF: Updated Rise and Fall Time. 5. Updated LF Ordering Information.	1, 2,3, 4, 15,18, 22
0.5	9/22/2005	1. Updated Output Features.	1
0.6	2/8/2006	Updated pin description pin 30/31 and 42/43	2-3
A	3/22/2006	1. Updated REF and USB cycle to cycle jitter specs to tentative SB600 requirements. 2. Updated CPU skew and jitter numbers 3. Updated SRC and ATIG skew and jitter numbers 4. Move Data sheet to Preliminary	17, 18
B	5/26/2006	1. Updated REF and USB rise/fall time specs to tentative SB600 requirements.	18
C	7/25/2006	Updated Reference to CLKREQB# on Byte 4 to CLKREQA#.	11
D	9/15/2006	Updated Recommended Application.	1, 4
E	12/5/2006	1. Updated Table 3 description. 2. Updated SMBus Pin# association.	7, 10-11
F	12/12/2006	1. Updated REF duty cycle to 56/44%.	18
G	1/30/2007	1. Updated REF Rise/Fall time spec	18
H	3/5/2007	1. Updated pinout and pin description for pin #61	1, 3
I	5/23/2007	Added Max Junction Temperature.	15
J	3/16/2009	Changed Cycle-to-cycle Jitter spec from 85 to 125ps.	17

IMPORTANT NOTICE AND DISCLAIMER

RENESAS ELECTRONICS CORPORATION AND ITS SUBSIDIARIES (“RENESAS”) PROVIDES TECHNICAL SPECIFICATIONS AND RELIABILITY DATA (INCLUDING DATASHEETS), DESIGN RESOURCES (INCLUDING REFERENCE DESIGNS), APPLICATION OR OTHER DESIGN ADVICE, WEB TOOLS, SAFETY INFORMATION, AND OTHER RESOURCES “AS IS” AND WITH ALL FAULTS, AND DISCLAIMS ALL WARRANTIES, EXPRESS OR IMPLIED, INCLUDING, WITHOUT LIMITATION, ANY IMPLIED WARRANTIES OF MERCHANTABILITY, FITNESS FOR A PARTICULAR PURPOSE, OR NON-INFRINGEMENT OF THIRD PARTY INTELLECTUAL PROPERTY RIGHTS.

These resources are intended for developers skilled in the art designing with Renesas products. You are solely responsible for (1) selecting the appropriate products for your application, (2) designing, validating, and testing your application, and (3) ensuring your application meets applicable standards, and any other safety, security, or other requirements. These resources are subject to change without notice. Renesas grants you permission to use these resources only for development of an application that uses Renesas products. Other reproduction or use of these resources is strictly prohibited. No license is granted to any other Renesas intellectual property or to any third party intellectual property. Renesas disclaims responsibility for, and you will fully indemnify Renesas and its representatives against, any claims, damages, costs, losses, or liabilities arising out of your use of these resources. Renesas' products are provided only subject to Renesas' Terms and Conditions of Sale or other applicable terms agreed to in writing. No use of any Renesas resources expands or otherwise alters any applicable warranties or warranty disclaimers for these products.

(Disclaimer Rev.1.0 Mar 2020)

Corporate Headquarters

TOYOSU FORESIA, 3-2-24 Toyosu,
Koto-ku, Tokyo 135-0061, Japan
www.renesas.com

Contact Information

For further information on a product, technology, the most up-to-date version of a document, or your nearest sales office, please visit:
www.renesas.com/contact/

Trademarks

Renesas and the Renesas logo are trademarks of Renesas Electronics Corporation. All trademarks and registered trademarks are the property of their respective owners.