

APPROVED: \_\_\_\_\_  
 DATE: \_\_\_\_\_ TITLE: \_\_\_\_\_

Rev	AWO #	Description	Date	Appr
-		RELEASED	11/16/20	

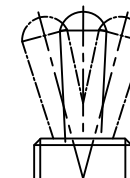
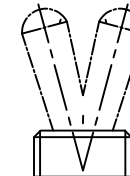
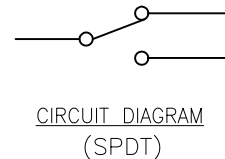
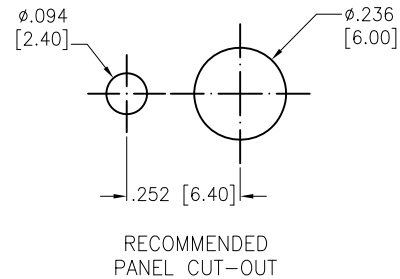
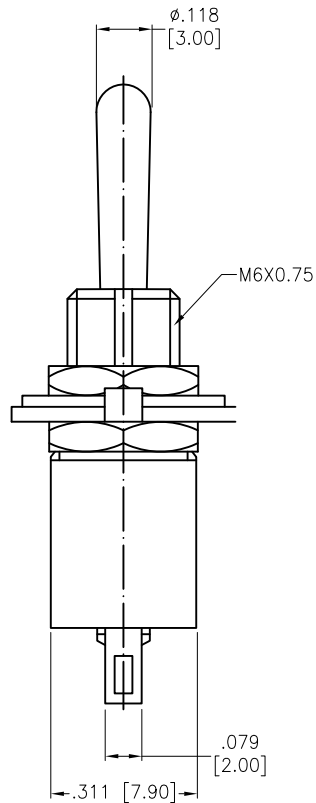
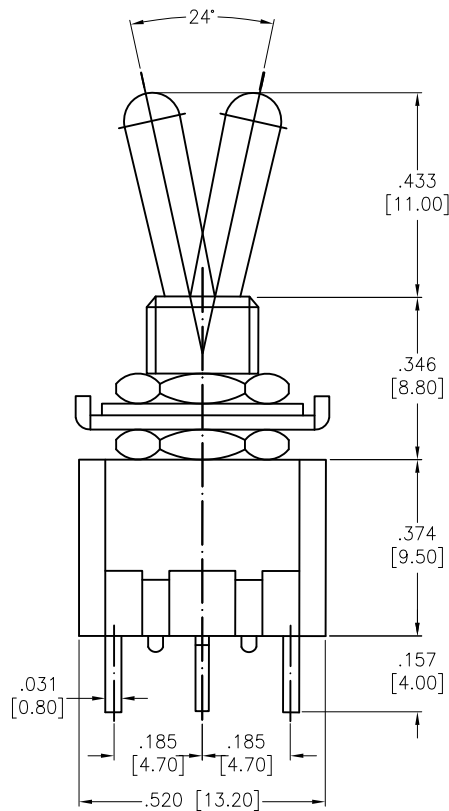

- SW-T2-2X-A-A2-M1
- B=ON-ON
  - D=ON-(ON)
  - E=ON-OFF-ON
  - F=ON-OFF-(ON)
  - G=(ON)-OFF-(ON)

**SPECIFICATIONS:**

**Material:**

Body: Bakelite, Color: Black

Lever: Brass, Nickel plated

Terminal: Brass, Silver plated

**Electrical:**

Rating: 3A @ 250V AC

6A @ 125V AC

Contact resistance: 20 mΩ max

Insulation resistance: 1000 MΩ min (500VDC)

Dielectric withstanding voltage: 1500V AC for 1 minute

Electrical Life: 10,000 cycles

Temperature Rating:

Operating temperature: -25°C to +85°C

Environmental:

Lead free, RoHS compliant



UNLESS OTHERWISE SPECIFIED ALL DIMENSIONS ARE INCHES [MM]. TOLERANCES: EXCEPT AS NOTED

INCHES	HOLES
.X ± .10	ØX ± .10
.XX ± .020	ØXX ± .015
.XXX ± .015	ØXXX ± .010



909 Rahway Avenue,  
 Union, NJ 07083  
 Phone: 908-687-5000  
 Fax: 908-687-5710

DRAWN	OW	11/16/20
CHECKED	AC	11/16/20
APPROVED		

TITLE SWITCH, TOGGLE MINIATURE, SPDT, SOLDER TYPE

THIS DRAWING CONTAINS INFORMATION THAT IS PROPRIETARY AND SHOULD NOT BE USED WITHOUT PRIOR WRITTEN PERMISSION FROM ADAM TECH

SIZE X	PART NO. SW-T2-2X-A-A2-M1	REV. -
REF: S00204C	SCALE: NTS	SHEET 1 OF 1