

# MLX90374 - Triaxis<sup>®</sup> Position Processor

Datasheet

## Features and Benefits

- **Triaxis<sup>®</sup>** Hall Technology
- On Chip Signal Processing for Robust Absolute Position Sensing
- **ASIL<sup>®</sup> READY** BY MELEXIS ISO26262 ASIL-C Safety Element out of Context
- AEC-Q100 Qualified
- Programmable Measurement Range
- Programmable Linear Transfer Characteristic (4 or 8 Multi-points or 16 or 32 PWL)
- PWM Redundant Dual Output
- SENT and Programmable Switch Dual Output
- SAE J2716 APR2016 SENT
- Enhanced serial data communication
- 48 bits ID Number option
- Single Die - SOIC-8 Package (RoHS)
- PCB-less DMP-4 Package (RoHS)
- Robustness against stray-field

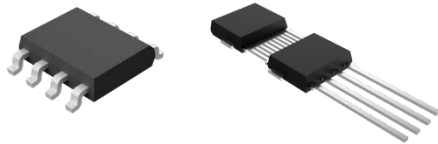

SOIC-8

DMP-4

## Application Examples

- Absolute Rotary Position Sensor
- Pedal Position Sensor
- Throttle Position Sensor
- Ride Height Position Sensor
- Absolute Linear Position Sensor
- Steering Wheel Position Sensor
- Float-Level Sensor
- Non-Contacting Potentiometer

## Description

The MLX90374 is a monolithic magnetic position processor IC. It consists of a Triaxis<sup>®</sup> Hall magnetic front end, an analog to digital signal conditioner, a DSP for advanced signal processing and a dual output stage driver.

The MLX90374 is sensitive to the three components of the magnetic flux density applied to the IC (i.e. B<sub>x</sub>, B<sub>y</sub> and B<sub>z</sub>). This allows the MLX90374 with the correct magnetic circuit to decode the absolute position of any moving magnet (e.g. rotary position from 0 to 360 Degrees or linear displacement, see fig. 2). It enables the design of non-contacting position sensors that are frequently required for both automotive and industrial applications.

The MLX90374 provides either a dual PWM output or a combination of SENT plus a programmable switch function. In dual PWM output mode, the circuit offers a wide panel of configurations from fully redundant signals to individually configurable outputs, including the choice between several error reporting modes. In SENT mode, the circuit delivers enhanced serial messages consisting of error codes, and user-defined values.

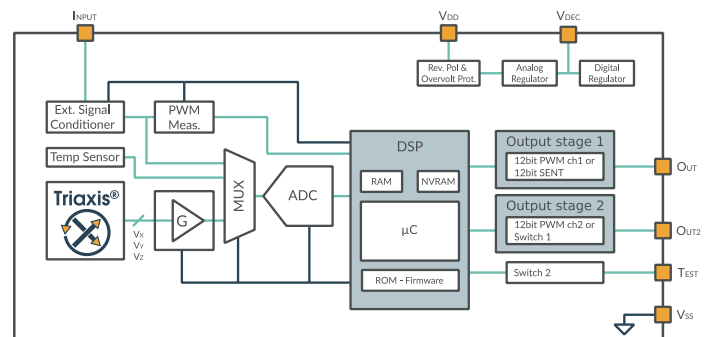

## Ordering Information

Product	Temp.	Package	Option Code	Packing Form	Definition
MLX90374	G	DC	ABB-200	RE	Linear position Strayfield Immune
MLX90374	G	DC	ABB-300	RE	Angular Rotary / Linear position
MLX90374	G	VS	ABB-200	RE/RX	Linear position Strayfield Immune
MLX90374	G	VS	ABB-207	RE/RX	Linear position Strayfield Immune
MLX90374	G	VS	ABB-300	RE/RX	Angular Rotary / Linear position
MLX90374	G	VS	ABB-307	RE/RX	Angular Rotary / Linear position
MLX90374	G	DC	ABC-100	RE	Angular Rotary Strayfield Immune
MLX90374	G	DC	ABC-200	RE	Linear position Strayfield Immune
MLX90374	G	DC	ABC-300	RE	Angular Rotary / Linear position
MLX90374	G	VS	ABC-100	RE/RX	Angular Rotary Strayfield Immune
MLX90374	G	VS	ABC-107	RE/RX	Angular Rotary Strayfield Immune
MLX90374	G	VS	ABC-200	RE/RX	Linear position Strayfield Immune
MLX90374	G	VS	ABC-207	RE/RX	Linear position Strayfield Immune
MLX90374	G	VS	ABC-300	RE/RX	Angular Rotary / Linear position
MLX90374	G	VS	ABC-307	RE/RX	Angular Rotary / Linear position

Table 1 - Ordering Codes

<b>Temperature Code:</b>	<b>G: from -40°C to 160°C</b>
Package Code:	DC : SOIC-8 package (see 17.1) VS : DMP-4 package (PCB-less dual mold, see 17.6)
Option Code - Chip revision	<b>ABC-123 : Chip Revision</b> <ul style="list-style-type: none"> <li>▪ ABB : Not recommended for new designs <sup>(1)</sup></li> <li>▪ ABC : Standard preferred revision <sup>(1)</sup></li> </ul>
Option Code - Application	<b>ABC-123 : 1-Application - Magnetic configuration</b> <ul style="list-style-type: none"> <li>▪ 1: Angular Rotary Strayfield Immune</li> <li>▪ 2: Linear position Strayfield Immune</li> <li>▪ 3: Legacy / Angular Rotary / Linear position</li> </ul>

<sup>1</sup> ABC is preferred product revision to be selected for new designs. ABB remains in production during the entire product lifecycle but does not include all the features of the ABC revision.

Option Code - SW & DMP-4 configuration	<p><b>ABC-123: 2-SW and DMP-4 package configuration</b></p> <p>For SOIC-8 (code DC) packages</p> <ul style="list-style-type: none"> <li>▪ 0: 2x PWM / SENT 3μs mode</li> </ul> <p>For DMP-4 (code VS) package (see section 14.2)</p> <ul style="list-style-type: none"> <li>▪ 0 : 2x PWM / SENT 3 μs mode (C<sub>1</sub>, C<sub>4</sub> = 10nF)</li> </ul>
Option Code - Trim & Form	<p><b>ABC-123: 3 - DMP-4 Trim &amp; Form configuration</b></p> <ul style="list-style-type: none"> <li>▪ 0: Standard straight leads. See section 17.5</li> <li>▪ 7: Trim and Form STD3 2.00 See section 17.6</li> </ul>
Packing Form:	<p>-RE : Tape &amp; Reel</p> <ul style="list-style-type: none"> <li>▪ VS:2500 pcs/reel</li> <li>▪ DC:3000 pcs/reel</li> </ul> <p>-RX : Tape &amp; Reel, similar to RE with parts face-down (VS package only)</p>
Ordering Example:	<p>MLX90374GVS-ABC-307-RX</p> <p>For a legacy version in DMP-4 package with trim and form STD3 2.00, delivered in Reel face down.</p>

*Table 2 - Ordering Codes Information*

## Contents

Features and Benefits.....	1
Application Examples.....	1
Description.....	1
Ordering Information .....	2
1. Functional Diagram and Application Modes.....	6
2. Glossary of Terms .....	7
3. Pin Definitions and Descriptions.....	8
3.1. Pin Definition for SOIC-8 package.....	8
3.2. Pin Definition for DMP.....	8
4. Absolute Maximum Ratings.....	9
5. General Electrical Specifications.....	10
6. Timing Specification.....	12
6.1. General Timing Specifications .....	12
6.2. Timing Modes .....	12
6.3. Timing Definitions.....	14
6.4. PWM timing specifications .....	16
6.5. SENT timing specifications.....	17
7. Magnetic Field Specifications .....	20
7.1. Rotary Stray-field Immune Mode (-100 code).....	20
7.2. Linear Stray-field Immune .....	21
7.3. Standard/Legacy Mode.....	22
8. Accuracy Specifications.....	24
8.1. Definition .....	24
8.2. Rotary Stray-field Immune (-100 code) .....	25
8.3. Linear Stray-field Immune Mode (-200 code) .....	26
8.4. Standard/Legacy Mode (-300 code) .....	27
9. Memory Specifications.....	28
10. Digital output protocol.....	29
10.1. PWM (pulse width modulation).....	29
10.2. Single Edge Nibble Transmission (SENT) SAE J2716 .....	30
11. End-User Programmable Items.....	38
11.1. End User Identification Items .....	44
12. Description of End-User Programmable Items .....	45

12.1. Sensor Front-End .....	45
12.2. Sensor DSP Configuration .....	46
12.3. Selection of Output modes .....	56
12.4. Programmable Diagnostics Settings .....	59
<b>13. Functional Safety .....</b>	<b>62</b>
13.1. Safety Manual .....	62
13.2. Safety Mechanisms .....	62
<b>14. Recommended Application Diagrams .....</b>	<b>66</b>
14.1. Wiring with the MLX90374 in SOIC-8 Package .....	66
14.2. Wiring with the MLX90374 in DMP-4 Package (built-in capacitors) .....	67
<b>15. Standard information regarding manufacturability of Melexis products with different soldering processes .....</b>	<b>68</b>
<b>16. ESD Precautions .....</b>	<b>68</b>
<b>17. Package Information .....</b>	<b>69</b>
17.1. SOIC-8 - Package Dimensions .....	69
17.2. SOIC-8 - Pinout and Marking .....	69
17.3. SOIC-8 - Sensitive spot positioning .....	70
17.4. SOIC-8 - Angle detection .....	71
17.5. DMP-4 - Package Outline Dimensions (POD) STD1 1.27 .....	72
17.6. DMP-4 - Package Outline Dimensions (POD) STD3 2.00 .....	73
17.7. DMP-4 - Marking .....	74
17.8. DMP-4 - Sensitive Spot Positioning .....	74
17.9. DMP-4 - Angle detection MLX90374 DMP-4 .....	76
17.10. Packages Thermal Performances .....	76
<b>18. Contact .....</b>	<b>77</b>
<b>19. Disclaimer .....</b>	<b>77</b>

# 1. Functional Diagram and Application Modes

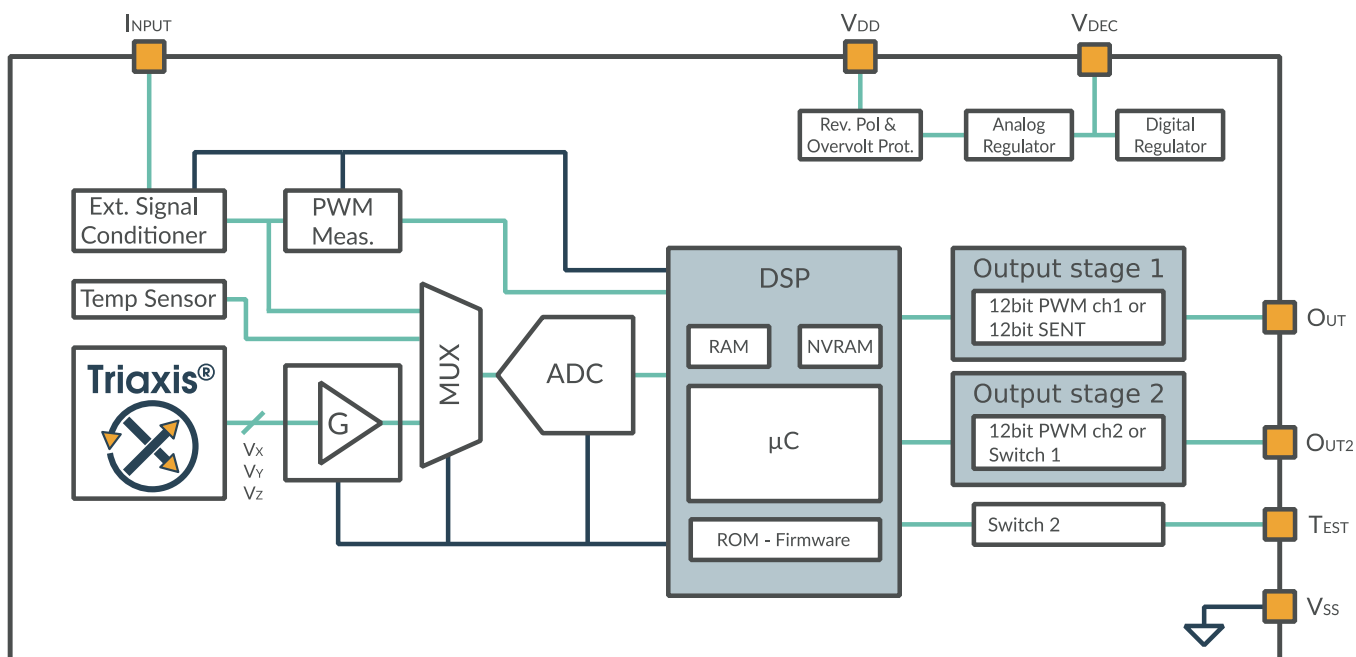

fig. 1 - MLX90374 Block diagram

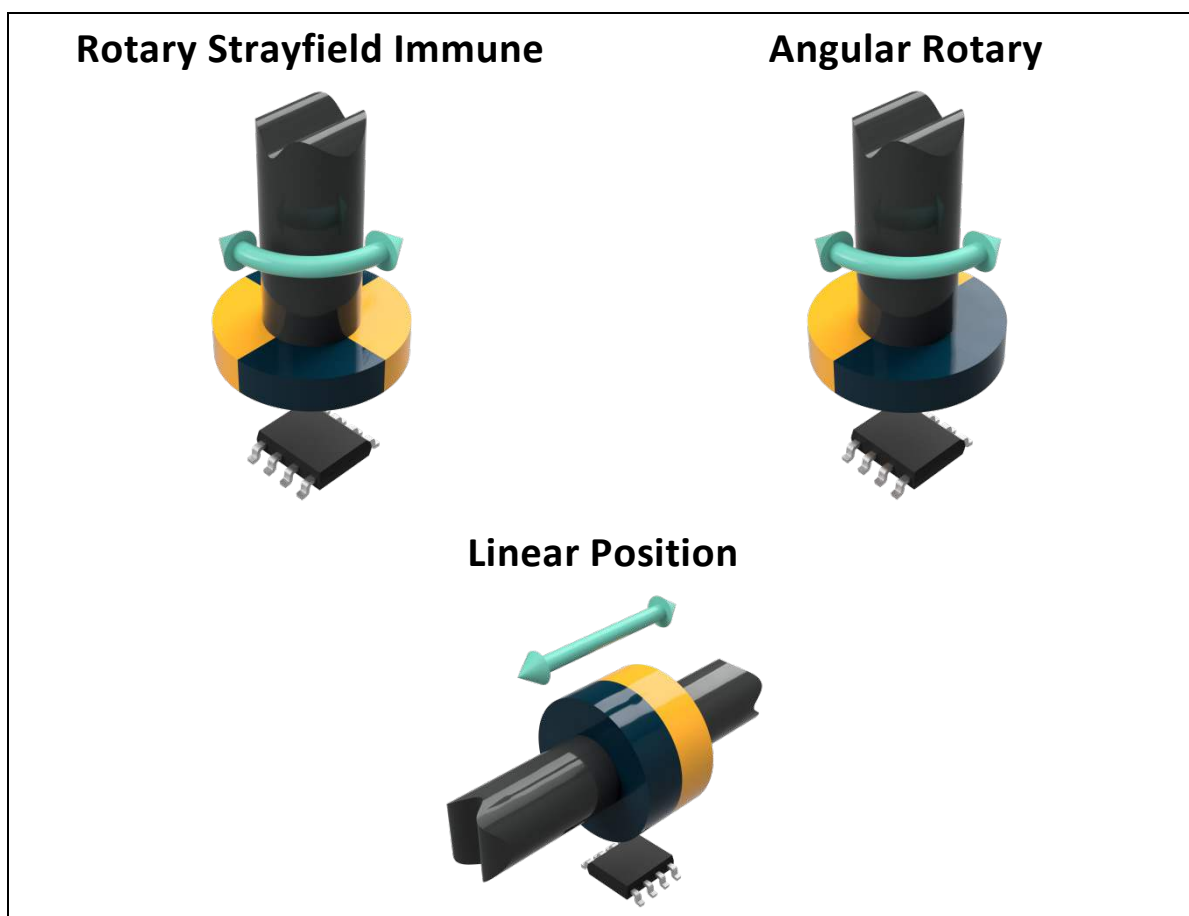

fig. 2 - Application Modes

## 2. Glossary of Terms

Name	Description
ADC	Analog-to-Digital Converter
AoU	Assumption of Use
ASP	Analog Signal Processing
AWD	Absolute Watchdog
CPU	Central Processing Unit
CRC	Cyclic Redundancy Check
%DC	Duty Cycle of the output signal i.e. $T_{ON} / (T_{ON} + T_{OFF})$
DMP	Dual Mold Package
DP	Discontinuity Point
DCT	Diagnostic Cycle Time
DSP	Digital Signal Processing
ECC	Error Correcting Code
EMA	Exponential Moving Average
EMC	Electro-Magnetic Compatibility
EoL	End of Line
FIR	Finite Impulse Response
Gauss (G)	Alternative unit for the magnetic flux density (10G = 1mT)
HW	Hardware
IMC	Integrated Magnetic Concentrator
INL / DNL	Integral Non-Linearity / Differential Non-Linearity
IWD	Intelligent Watchdog
LSB/MSB	Least Significant Bit / Most Significant Bit
NC	Not Connected
NVRAM	Non Volatile RAM
POR	Power On Reset
PSF	Product Specific Functions
PWL	Piecewise Linear
PWM	Pulse Width Modulation
RAM	Random Access Memory
ROM	Read-Only Memory
SEooC	Safety Element out of Context
TC	Temperature Coefficient (in ppm/°C)
Tesla (T)	SI derived unit for the magnetic flux density (Vs/m <sup>2</sup> )

Table 3 - Glossary of Terms

## 3. Pin Definitions and Descriptions

### 3.1. Pin Definition for SOIC-8 package

Pin #	Name	Description
1	V <sub>DD</sub>	Supply
2	Input	For test or Application
3	OUT <sub>2</sub>	Second Output
4	Test	For test or application
5	OUT <sub>1</sub>	First Output
6	V <sub>SS</sub>	Digital ground
7	V <sub>DEC</sub>	Decoupling pin
8	V <sub>SS</sub>	Analog ground

*Table 4 - SOIC-8 Pins definition and description*

Pins Input and Test are internally grounded in application. For optimal EMC behaviour always connect the unused pins to the electrical ground of the PCB.

### 3.2. Pin Definition for DMP

DMP-4 package adds a dual output PCB-less solution to the Triaxis® product family.

Pin #	Name	Description
1	OUT <sub>1</sub>	First Output
2	V <sub>SS</sub>	Ground
3	V <sub>DD</sub>	Supply
4	OUT <sub>2</sub>	Second Output

*Table 5 - DMP-4 Pins definition and description*



## 4. Absolute Maximum Ratings

Parameter	Symbol	Min	Max	Unit	Condition
Supply Voltage	$V_{DD}$		27	V	< 48h ; $T_j < 175^{\circ}\text{C}$
	$V_{DD}$		37	V	< 60s ; $T_{AMB} < 35^{\circ}\text{C}$
Reverse Voltage Protection	$V_{DD\text{-rev}}$	-14		V	< 48h
	$V_{DD\text{-rev}}$	-20		V	< 1h
Positive Output Voltage	$V_{OUT}$		27	V	< 48h
Reverse Output Voltage	$V_{OUT\text{-rev}}$	-14		V	< 48h
Internal Voltage	$V_{DEC}$		3.6	V	
	$V_{DEC\text{-rev}}$	-0.3		V	
Positive Input pin Voltage	$V_{Input}$		6	V	
Reverse Input pin Voltage	$V_{Input\text{-rev}}$	-3		V	
Test pin Voltage	$V_{TEST}$		3.6	V	
	$V_{TEST\text{-rev}}$	-0.3		V	
Operating Temperature	$T_{AMB}$	-40	+160	$^{\circ}\text{C}$	
Junction Temperature	$T_j$		+175	$^{\circ}\text{C}$	see 17.10 for package thermal dissipation values
Storage Temperature	$T_{ST}$	-55	+170	$^{\circ}\text{C}$	
Magnetic Flux Density	$B_{max}$	-1	1	T	

Table 6 - Absolute maximum ratings

Exceeding the absolute maximum ratings may cause permanent damage.

Exposure to absolute maximum ratings conditions for extended periods may affect device reliability.

## 5. General Electrical Specifications

General electrical specifications are valid for temperature range [-40;160] °C and supply voltage range [4.5;5.5] V unless otherwise noted.

Electrical Parameter	Symbol	Min	Typ	Max	Unit	Condition
Supply Voltage	V <sub>DD</sub>	4.5	5	5.5	V	For voltage regulated mode
Supply Voltage Battery	V <sub>DD</sub>	6	12	18	V	For Battery usage <sup>(2)</sup>
Supply Current	I <sub>DD</sub>	9.0	10.5	12.6	mA	Rotary and linear stray field applications (option code -100, -200)
Supply Current	I <sub>DD</sub>	8.0	9.0	10.5	mA	Legacy applications (option code -300)
Surge Current	I <sub>surge</sub>	-	30	40	mA	IC Startup current (t <sub>startup</sub> < 40µs)
Start-up Level	V <sub>DDstart</sub>	3.6			V	Minimal supply start-up voltage
PTC Entry Level (rising)	V <sub>PROV0</sub>	7.10	7.35	7.70	V	Supply overvoltage detection in 5V applications <sup>(2)</sup>
PTC Entry Level Hysteresis	V <sub>PROV0Hyst</sub>	400	500	600	mV	
PTC Entry Level (rising)	V <sub>PROV1</sub>	21.5	23.0	24.5	V	For Battery usage <sup>(2)</sup>
PTC Entry Level Hysteresis	V <sub>PROV1Hyst</sub>	0.8	1.4	2.0	V	For Battery usage <sup>(2)</sup>
Under voltage detection	V <sub>DDUVH</sub>	3.95	4.10	4.25	V	Supply undervoltage high threshold
Under voltage detection	V <sub>DDUVL</sub>	3.75	3.90	4.05	V	Supply undervoltage low threshold
Regulated Voltage	V <sub>DEC</sub>	3.2	3.3	3.4	V	Internal analog voltage
Regulated Voltage Overvoltage detection	V <sub>DECOVH</sub>	3.65	3.75	3.85	V	High threshold
Regulated Voltage Undervoltage detection	V <sub>DECUVL</sub>	2.70	2.85	2.92	V	Low threshold
Regulated Voltage UV / OV detection hysteresis	V <sub>DECOVHyst</sub> V <sub>DECUVHyst</sub>	100	150	200	mV	
Digital supply	V <sub>DDD</sub>	1.80	1.85	1.95	V	
Digital supply Overvoltage detection	V <sub>DDDOVH</sub>	2.00	2.10	2.20	V	
Digital Supply Undervoltage detection	V <sub>DDDUVL</sub>	1.585	1.680	1.735	V	Power-on Reset low threshold
Digital Supply OV / UV detection Hysteresis	V <sub>PORHyst</sub>	30	100	200	mV	

Table 7 - Supply System Electrical Specifications

<sup>2</sup> Selection between 5V or battery applications is done using WARM\_ACT\_HIGH parameter. See chap.11

Electrical Parameter	Symbol	Min	Typ	Max	Unit	Condition
Output Short Circuit Current <sup>(3)</sup>	I <sub>OUTshortPP</sub>	-25		-10	mA	Push-pull modes (SENT, PWM) V <sub>OUT</sub> = 0 V
		8		15	mA	V <sub>OUT</sub> = 5 V .. 18V
Output Short Circuit Current	I <sub>OUTshortOD1</sub>	10		25	mA	V <sub>OUT</sub> = 5V
Output Short Circuit Current	I <sub>OUTshortOD2</sub>	40		90	mA	PWM mode Open Drain only (see 12.3.5)
Output Load	R <sub>L</sub>	3			kΩ	PWM pull-up to 5V, PWM pull-down to 0V
	R <sub>L</sub>	10	-	55	kΩ	SENT pull-up
	R <sub>L</sub>	1	-	100	kΩ	Open drain pull-up
Digital push-pull output level	V <sub>satLoPP</sub>	0	1	2 5	%V <sub>DD</sub>	R <sub>L</sub> ≥ 10kΩ R <sub>L</sub> ≥ 3kΩ, pull-up to 5V
	V <sub>satHiPP</sub>	98 95	99	100	%V <sub>DD</sub>	R <sub>L</sub> ≥ 10kΩ R <sub>L</sub> ≥ 3kΩ, pull-down
Digital open drain output level	V <sub>satLoOD</sub>	0		10	%V <sub>ext</sub>	Pull-up to any external voltage V <sub>ext</sub> ≤ 18V, I <sub>L</sub> ≤ 3.4mA
Digital output Ron	R <sub>on</sub>	27	50	100	Ω	Push-pull mode

Table 8 - Output Electrical specifications

<sup>3</sup> Output current limitation triggers after a typical delay of 3μs.

## 6. Timing Specification

Timing specifications are valid for temperature range [-40;160] °C and supply voltage range [4.5;5.5] V unless otherwise noted.

### 6.1. General Timing Specifications

Parameter	Symbol	Min.	Typ	Max.	Unit	Condition
Main Clock Frequency	$F_{CK}$	22.8	24	25.2	MHz	Including thermal and lifetime drift
		-5		5	% $F_{ck}$	Relative tolerances, including thermal and lifetime drift
Main Clock initial tolerances	$\Delta F_{CK,0}$	23.75	24	24.25	MHz	T=35°C
Main Clock Frequency Thermal Drift	$\Delta F_{CK,T}$	-2	-	2	% $F_{ck}$	Relative to clock frequency at 35°C. No ageing effects.
1MHz Clock Frequency	$F_{1M}$		1		MHz	
Intelligent Watchdog Timeout	$T_{IWD}$	19	20	21	ms	$F_{CK} = 24\text{MHz}$
Absolute Watchdog Timeout	$T_{AWD}$	19	20	21	ms	$F_{1M} = 1\text{MHz}$
Analog Diagnostics DCT	$DCT_{ANA}$	34		34	$T_{angle\ Meas}$	PWM or SENT Asynchronous mode (6.2.1)
		17		17	$T_{frame}$	SENT Sync. Mode, $N_{angFram}=2$
		34		34	$T_{frame}$	SENT Sync. Mode, $N_{angFram}=1$
Digital Diagnostics DCT	$DCT_{DIG}$			20	ms	see Table 67, section 13.2
Fail Safe state duration	$T_{FSS}$	9.8	11.0	11.9	ms	After a digital single-event fault ABC revision
		28.4	32.0	34.6		ABB revision
Safe Startup Time	$T_{SafeStup}$	-	11.2	12.4	ms	Only valid for ABC revision (see 6.3.1.2)

Table 9 - General Timing Specifications

### 6.2. Timing Modes

The MLX90374 can be configured in two continuous angle acquisition modes described in the following sections.

#### 6.2.1. Continuous Asynchronous Acquisition Mode

In this mode, the sensor continuously acquire angle at a fixed rate that is asynchronous with regards to the output. The acquisition rate is defined by the variable  $T_{ADC\_SEQ}$  parameter which defines the angle measurement period  $T_{angleMeas}$ . This mode is used in PWM and SENT without pause. Even though PWM is periodic, asynchronous mode is better suited and enables complete filtering options for PWM signals that are often slow compared to the sensor internal measurement sequence.

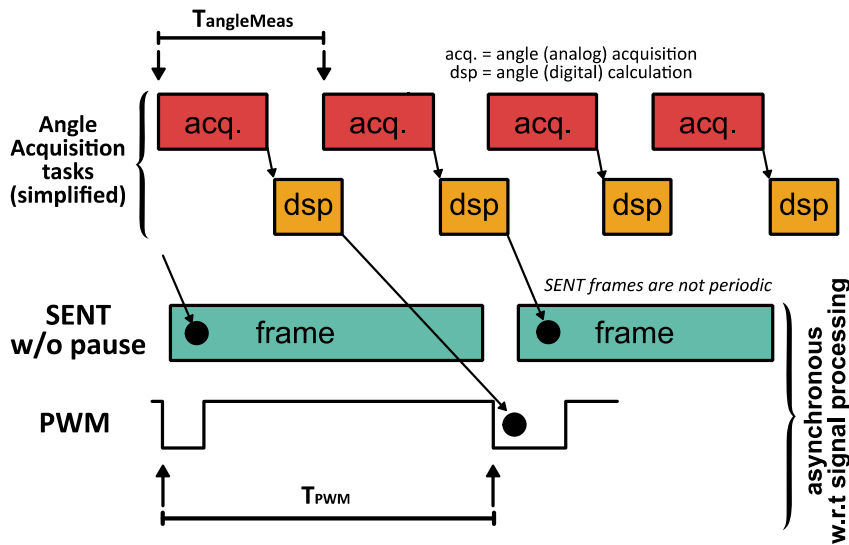

fig. 3 - Continuous Asynchronous Timing Mode

Parameter	Symbol	Min.	Typ	Max.	Unit	Condition
Angle acquisition time	$T_{\text{angleAcq}}$		330		$\mu\text{s}$	
Internal Angle Measurement Period	$T_{\text{angleMeas}}$	528	588	-	$\mu\text{s}$	Typical is default factory settings (no user control)
SENT Frame Tick Count	$N_{\text{Tframe}}$	282	-	-	ticks	<b>Do not modify</b> for asynchronous mode (see chap.11, $T_{\text{FRAME}}$ )

Table 10 - Continuous Asynchronous Timing Mode

### 6.2.2. Continuous Synchronous Acquisition Mode

In continuous synchronous timing mode, the sensor acquires angles based on the output frequency. As a consequence, the output should have a fixed frame frequency. This mode is used only with constant SENT frame length (SENT with pause). The length of the SENT frame is defined by the parameter  $T_{\text{FRAME}}$  in number of ticks. The user has the choice to select either one or two angle acquisitions and DSP calculations per frame.

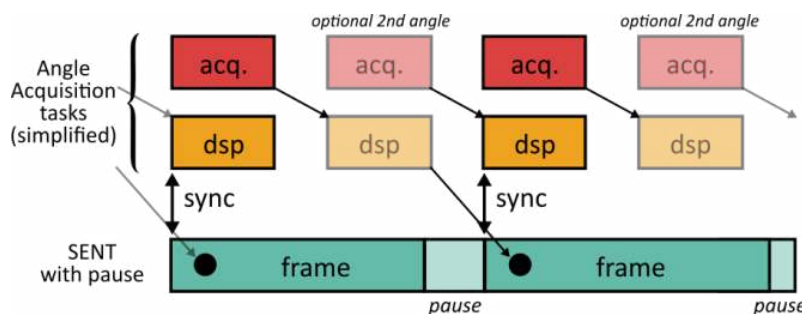

fig. 4 - Continuous Synchronous Timing Mode

Following table describes the frame length of synchronous acquisition mode with regards to T\_FRAME parameter value (see chap. 11). Minimal values represent MLX90374 best achievable performance. Typical values are default or recommended values. Maximal values are limited by the SAE J2716 standard and not displayed in this table. For a chosen timing configuration, one has to consider the main clock relative tolerances listed in Table 9 to get a tolerance on the frame duration.

Parameter	Symbol	Min	Typ	Max	Unit	Condition
SENT Frame Tick Count (Normal SENT)	$N_{Tframe}$	310 <sup>(4)</sup>	320	-	ticks	For tick time of 3μs (Normal SENT) and two angles per frame
SENT Frame Tick Count (Normal SENT)	$N_{Tframe}$	282 <sup>(4)</sup>	304 <sup>5</sup>	-	ticks	For tick time of 3μs (Normal SENT) and one angle per frame
SENT Frame Tick Count (Fast SENT)	$N_{Tframe}$	320 <sup>(4)</sup>	330	-	ticks	For tick time of 1.5μs (Fast SENT) and one angle per frame
SENT Frame Period (Normal SENT)	$T_{frame}$	930 <sup>(4)</sup>	960	-	μs	3μs tick time with pause and two angles per frame ( $F_{CK} = 24MHz$ )
SENT Frame Period (Fast)	$T_{frame}$	480 <sup>(4)</sup>	495	-	μs	1.5μs tick time with pause, one angle per frame ( $F_{CK} = 24MHz$ )
Number of angles per frame	$N_{angFram}$	1	2			set by TWO_ANGLE_FRAME parameter

Table 11 - SENT Synchronous Timing Mode Configuration

### 6.3. Timing Definitions

#### 6.3.1. Startup Time

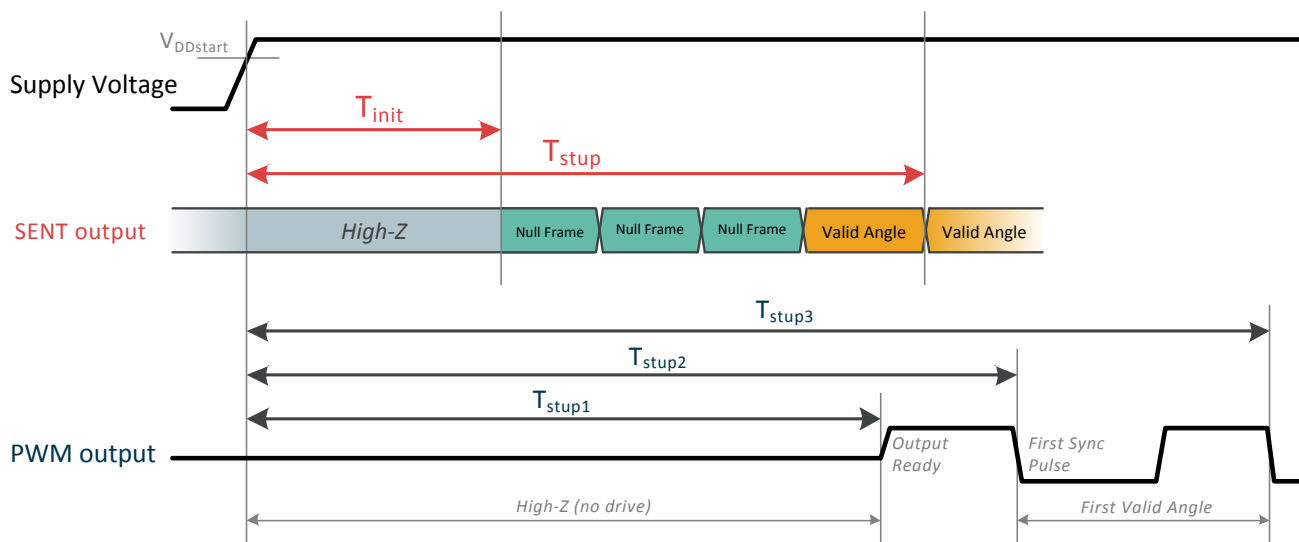

fig. 5 - Startup Time Definition

<sup>4</sup> Minimal timings are only confirmed to work in a specific configuration and may lead to noise degradation. Melexis recommends typical configuration (factory settings) for safe operation with any end user configuration.

<sup>5</sup> This timing optimizes the startup time (see Table 14)

### 6.3.1.1. Normal Startup

A typical startup in SENT consists of two main phases. During the first one, the circuit performs its initialisation until being able to start acquiring angles and transmitting SENT frames. This first phase lasts  $T_{init}$  milliseconds. After that time, the IC starts transmitting SENT initialisation frames, also called null frames, their content being mainly zeros. During the second phase, the sensor acquires angles until the amplification chain gain settles. The overall startup time  $T_{stup}$  is the time between power up and complete transmission of the first valid angle.

### 6.3.1.2. Safe Startup

When COLD\_SAFE\_STARTUP\_EN is set (see chap.11, End-User Programmable Items), the circuit performs a full diagnostic cycle before starting the transmission of an angle. This sequence lasts  $T_{SafeStup}$  milliseconds (see Table 9 - General Timing Specifications). After  $T_{init}$ , the circuit start sending null SENT frames until the full diagnostic sequence is complete.

### 6.3.1.3. Startup phase in PWM mode

In PWM mode, startup is defined by three values,  $T_{stup[1..3]}$ . The first value is reached when the output is ready and starts to drive a voltage. The second value  $T_2$  is the start of the first value angle transmission and the third one  $T_3$  the moment the first angle has been transmitted.

## 6.3.2. Latency (average)

Latency is the average lag between the movement of the detected object (magnet) and the response of the sensor output. This value is representative of the time constant of the system for regulation calculations.

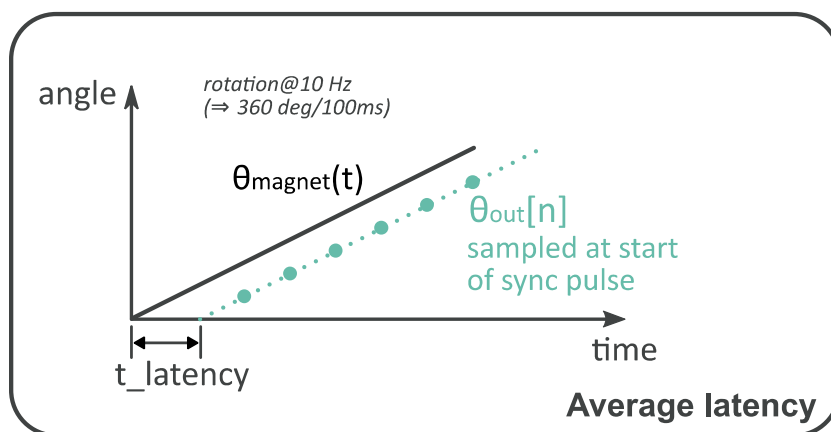

fig. 6 - Definition of Latency

### 6.3.3. Step Response (worst case)

Step response is defined as the delay between a change of position of the magnet and the 100% settling time of the sensor output with full angle accuracy with regards to filtering. Worst case is happening when

the movement of the magnet occurs just after a measurement sequence has begun. Step response therefore consists of the sum of:

- $\delta_{mag, measSeq}$ , the delay between magnetic change and start of next measurement sequence
- $T_{measSeq}$ , the measurement sequence length
- $\delta_{measSeq, frameStart}$ , the delay between end of measurement sequence and start of next frame
- $T_{frame}$ , the frame length

For worst case, the measurement sequence length is considered for  $\delta_{mag, measSeq}$ . This gives:

$$T_{wcStep} = 2T_{measSeq} + \delta_{measSeq, frameStart} + T_{frame}$$

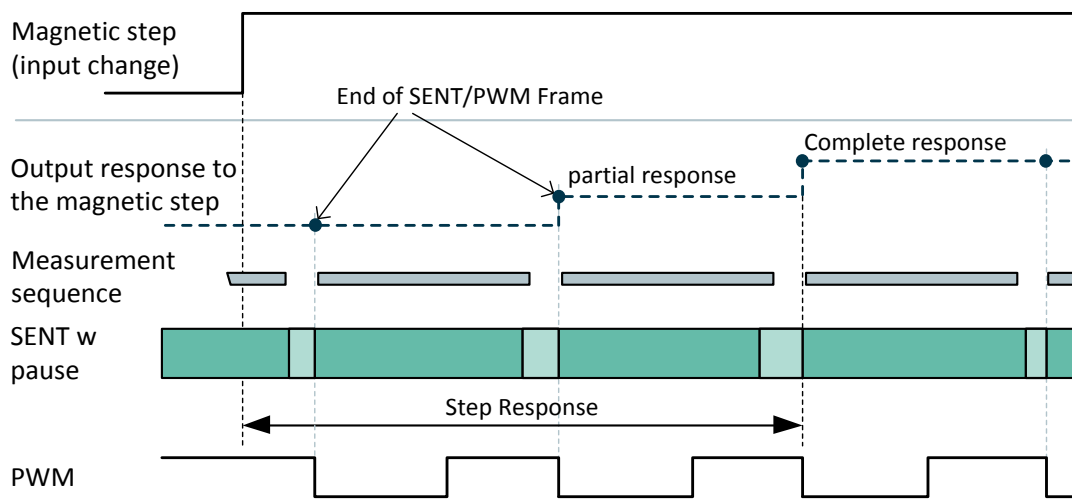

fig. 7 - Step Response Definition

## 6.4. PWM timing specifications

Parameter	Symbol	Min	Typ	Max	Unit	Condition
PWM Frequency	$F_{PWM}$	100	1000	2000	Hz	
PWM Frequency Initial Tolerances	$\Delta F_{PWM,0}$	-1.5		1.5	% $F_{PWM}$	T=35°C, can be trimmed at EOL
PWM Frequency Thermal Drift	$\Delta F_{PWM,T}$	-2.0		2.0	% $F_{PWM}$	
PWM Frequency Drift	$\Delta F_{PWM}$	-5.0		5.0	% $F_{PWM}$	Over temperature and lifetime
PWM startup Time (up to output ready)	$T_{stup1}$		6.60		ms	
PWM startup Time (up to first sync. Edge)	$T_{stup2}$	7.10	7.60	16.6	ms	$T_{stup1} + T_{PWM}$



Parameter	Symbol	Min	Typ	Max	Unit	Condition
PWM startup Time (up to first data received)	T <sub>stup3</sub>	7.60	8.60	26.6	ms	T <sub>stup1</sub> + 2* T <sub>PWM</sub> <sup>(6)</sup>
Rise Time PWM	t <sub>rise</sub>	1.0	4.8	12.0	μs	typ. with SENT_SEL_SR_RISE/FALL = 4 (see 10.2.6). Measured between 1.1V and 3.8V
Fall Time PWM	t <sub>fall</sub>	1.0	4.8	12.0	μs	

Table 12 - PWM timing specifications

## 6.5. SENT timing specifications

Timing specifications are valid for a given configuration of the SENT frame and tick time (see 10.2.9).

Parameter	Symbol	Min	Typ	Max	Unit	Condition
Tick time		1.5	3	6	μs	1.5μs = Fast SENT 3μs = Normal SENT (default) 6μs = Slow SENT
SENT startup time (up to first sync pulse)	T <sub>init</sub>	-	2.95	3.10	ms	Until initialisation frame starts
SENT edge rise Time		4.5	6.2	7.5	μs	for SENT_SEL_SR_RISE/FALL =4 (see 10.2.6)
SENT edge fall Time		3.9	4.8	5.2	μs	
Slow Message cycle length			691 415		ms	Extended sequence ( 40 frames ) Short sequence (24 frames )

Table 13 - SENT General Timing Specifications

Parameter	Symbol	Min	Typ	Max	Unit	Condition
<b>For SENT with pause (synchronous), 3μs tick time, 2 angles per SENT frame, T_FRAME = 310</b>						
SENT startup time	T <sub>stup</sub>	-	6.48	-	ms	Until first valid angle received
Average Latency	T <sub>latcy</sub>	-	1.73 2.19	-	ms	Filter = 1 (FIR11) Filter = 2 (FIR1111) <sup>(7)</sup>
Step Response (worst case)	T <sub>wcStep</sub>	-	-	2.98 3.91	ms	Filter = 1 (FIR11) Filter = 2 (FIR1111) <sup>(7)</sup>
<b>For SENT with pause (synchronous), 3μs tick time, 2 angles per SENT frame, T_FRAME = 320</b>						
SENT startup time	T <sub>stup</sub>	-	6.60	-	ms	Until first valid angle received
Average Latency	T <sub>latcy</sub>	-	1.77 2.25	-	ms	Filter = 1 (FIR11) Filter = 2 (FIR1111) <sup>(7)</sup>
Step Response (worst case)	T <sub>wcStep</sub>	-	-	3.12 4.08	ms	Filter = 1 (FIR11) Filter = 2 (FIR1111) <sup>(7)</sup>

<sup>6</sup> First frame transmitted has no synchronization edge; therefore the second frame transmitted is the first complete one.

<sup>7</sup> See section 12.2.3 for details concerning Filter parameter

Parameter	Symbol	Min	Typ	Max	Unit	Condition
<b>For SENT with pause (synchronous), 3µs tick time, 1 angle per SENT frame, T_FRAME = 282</b>						
SENT startup time	T <sub>stup</sub>	-	6.99	-	ms	Until first valid angle received
Average Latency	T <sub>latcy</sub>	-	1.33	-	ms	Filter = 0 (no filter)
Step Response (worst case)	T <sub>wcStep</sub>	-	-	2.32	ms	Filter = 0 (no filter)
<b>For SENT with pause (synchronous), 3µs tick time, 1 angle per SENT frame, T_FRAME = 304</b>						
SENT startup time	T <sub>stup</sub>	-	6.41	-	ms	Until first valid angle received
Average Latency	T <sub>latcy</sub>	-	1.54	-	ms	Filter = 0 (no filter)
Step Response (worst case)	T <sub>wcStep</sub>	-	-	2.60	ms	Filter = 0 (no filter)

Table 14 - Synchronous SENT Mode Timing Specifications for 3µs tick time

Parameter	Symbol	Min	Typ	Max	Unit	Condition
<b>For SENT with pause (synchronous), 1.5µs tick time, 1 angle per SENT frame, T_FRAME = 320</b>						
SENT startup time	T <sub>stup</sub>	6.12	6.23	-	ms	Until first valid angle received
Average Latency	T <sub>latcy</sub>	-	0.98	-	ms	Filter = 0 (no filter)
			1.15			Filter = 1 (FIR11)
			1.31			Filter = 2 (FIR1111) <sup>(7)</sup>
Step Response (worst case)	T <sub>wcStep</sub>	-	-	1.58	ms	Filter = 0 (no filter)
				1.89		Filter = 1 (FIR11)
				2.20		Filter = 2 (FIR1111) <sup>(7)</sup>
<b>For SENT with pause (synchronous), 1.5µs tick time, 1 angle per SENT frame, T_FRAME = 330</b>						
SENT startup time	T <sub>stup</sub>	6.12	6.23	-	ms	Until first valid angle received
Average Latency	T <sub>latcy</sub>	-	1.05	-	ms	Filter = 0 (no filter)
			1.21			Filter = 1 (FIR11)
			1.37			Filter = 2 (FIR1111) <sup>(7)</sup>
Step Response (worst case)	T <sub>wcStep</sub>	-	-	1.63	ms	Filter = 0 (no filter)
				1.95		Filter = 1 (FIR11)
				2.27		Filter = 2 (FIR1111) <sup>(7)</sup>

Table 15 - Synchronous SENT Mode Timing Specifications for 1.5µs tick time

Parameter	Symbol	Min	Typ	Max	Unit	Condition
<b>For SENT without pause (asynchronous), 3µs tick time<sup>(8)</sup></b>						
SENT startup time	T <sub>stup</sub>	6.25 6.42	6.39 6.56	6.51 6.68	ms	Until first valid angle received with SENT_INIT_GM = 1
Average Latency	T <sub>latcy</sub>	1.40	1.40			Filter = 0 (no filter)
		1.67	1.70	-	ms	Filter = 1 (FIR11)
		2.20	2.30			Filter = 2 (FIR1111) <sup>(7)</sup>
Step Response (worst case)	T <sub>wcStep</sub>	-	2.76 3.29	2.83 3.43	ms	Filter = 0 (no filter)
			4.35	4.63		Filter = 1 (FIR11)
						Filter = 2 (FIR1111) <sup>(7)</sup>
<b>For SENT without pause (asynchronous), 1.5µs tick time<sup>(8)</sup></b>						
SENT startup time	T <sub>stup</sub>	6.42	6.50	6.56	ms	Until first valid angle received
Average Latency	T <sub>latcy</sub>	0.91	0.91			Filter = 0 (no filter)
		1.17	1.21	-	ms	Filter = 1 (FIR11)
		1.70	1.81			Filter = 2 (FIR1111) <sup>(7)</sup>
Step Response (worst case)	T <sub>wcStep</sub>	-	1.71 2.19	2.01 2.61	ms	Filter = 0 (no filter)
			3.15	3.81		Filter = 1 (FIR11)
						Filter = 2 (FIR1111) <sup>(7)</sup>

Table 16 - Asynchronous SENT Mode Timing Specifications

<sup>8</sup> In asynchronous mode, the latency is defined as an average delay with regards to all possible variations. For worst case, refer to step response (worst case) values

## 7. Magnetic Field Specifications

Magnetic Field specifications are valid for temperature range [-40;160] °C unless otherwise noted.

### 7.1. Rotary Stray-field Immune Mode (-100 code)

Parameter	Symbol	Min	Typ	Max	Unit	Condition
Number of magnetic poles	$N_p$	4 <sup>(9)</sup>	-	-		
Magnetic Flux Density in X-Y plane	$B_x, B_y$ <sup>(10)</sup>			25 <sup>(11)</sup>	mT	$\sqrt{B_x^2 + B_y^2}$ (this is not the useful signal)
Magnetic Flux Density in Z	$B_z$			100	mT	(this is not the useful signal)
Magnetic in-plane gradient of in-plane field component	$\frac{\Delta B_{XY}}{\Delta XY}$	3.8	10		$\frac{mT}{mm}$	$\frac{1}{2} \sqrt{\left(\frac{dB_x}{dX} - \frac{dB_y}{dY}\right)^2 + \left(\frac{dB_x}{dY} + \frac{dB_y}{dX}\right)^2}$ this is the useful signal (see fig. 8)
Magnet Temperature Coefficient	$TC_m$	-2400		0	$\frac{ppm}{^\circ C}$	
Field Strength Resolution <sup>(12)</sup>	$\frac{\Delta B_{XY}}{\Delta XY}$	0.075	0.1	0.125	$\frac{mT}{mm}$ LSB	Magnetic field gradient norm (12bits data)
Field too Low Threshold <sup>(13)</sup>	$B_{TH\_LOW}$	0.8	1.2	<sup>(14)</sup>	$\frac{mT}{mm}$	Typ is recommended value to be set by user
Field too High Threshold <sup>(13)</sup>	$B_{TH\_HIGH}$	70	100 <sup>(15)</sup>	102 <sup>(15)</sup>	$\frac{mT}{mm}$	Typ is recommended value to be set by user

Table 17 - Magnetic specification for rotary stray-field immune

Nominal performances apply when the useful signal  $\Delta B_{XY}/\Delta XY$  is above the typical specified limit. Under this value, limited performances apply. See 8.2 for accuracy specifications.

<sup>9</sup> Due to 4 poles magnet usage, maximum angle measurement range is limited to 180°

<sup>10</sup> The condition must be fulfilled for all combinations of Bx and By.

<sup>11</sup> Above this limit, the IMC® starts to saturate, yielding to an increase of the linearity error.

<sup>12</sup> Only valid with default MAGNET\_SREL\_T[1..7] configuration

<sup>13</sup> Typ. value is set by default for NVRAM rev.9 and shall be set by user for rev.8 (see Table 43, USER\_ID1 and Table 42)

<sup>14</sup> Higher values of Field too Low threshold are not recommended by Melexis and shall only be set in accordance with the magnetic design and taking a sufficient safety margin to prevent false positive.

<sup>15</sup> Due to the saturation effect of the IMC, the FieldTooHigh monitor detects only defects in the sensors

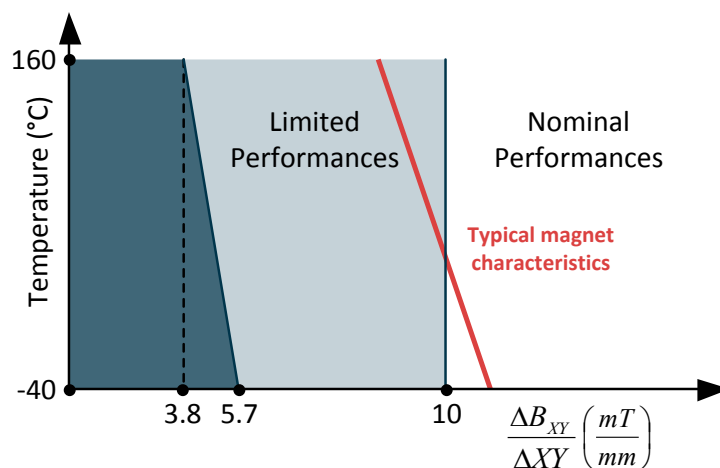

fig. 8 - Minimum useful signal definition for rotary stray-field immune application

## 7.2. Linear Stray-field Immune (-200 code)

Parameter	Symbol	Min	Typ	Max	Unit	Condition
Number of magnetic poles	$N_p$		2	-		Linear movement
Magnetic Flux Density in X	$B_x$			80 <sup>(16)</sup>	mT	$B_y \leq 20\text{mT}$
Magnetic Flux Density in X-Y	$B_x, B_y$ <sup>(17)</sup>			70 <sup>(18)</sup>	mT	$\sqrt{B_x^2 + B_y^2}, B_y > 20\text{mT}$
Magnetic Flux Density in Z	$B_z$			100	mT	
Magnetic gradient of X-Z field components	$\frac{\Delta B_{XZ}}{\Delta X}$	3	6 <sup>(19)</sup>		$\frac{\text{mT}}{\text{mm}}$	$\sqrt{\left(\frac{\Delta B_X}{\Delta X}\right)^2 + \left(\frac{1}{G_{IMC}} \frac{\Delta B_Z}{\Delta X}\right)^2}$ <sup>(20)</sup>
Distance between the two IMC®	$\Delta X$		1.91		mm	see chapter 17 for magnetic center definitions
IMC gain	$G_{IMC}$		1.19			see <sup>(20)</sup>
Magnet Temperature Coefficient	$TC_m$	-2400		0	$\frac{\text{ppm}}{^\circ\text{C}}$	
Field Strength Resolution <sup>(12)</sup>	$\frac{\Delta B_{XZ}}{\Delta X}$	0.037	0.05	0.063	$\frac{\text{mT}}{\text{mm LSB}}$	Magnetic field gradient norm expressed in 12bits words
Field too Low Threshold <sup>(13)</sup>	$B_{TH\_LOW}$	0.2	1.2	<sup>(21)</sup>	$\frac{\text{mT}}{\text{mm}}$	Typ is recommended value to be set by user
Field too High Threshold <sup>(13)</sup>	$B_{TH\_HIGH}$	35	50	51	$\frac{\text{mT}}{\text{mm}}$	Typ is recommended value to be set by user

Table 18 - Magnetic specifications for linear stray-field application

<sup>16</sup> Above 80 mT, with  $B_Y$  field in the mentioned limits, the IMC® starts saturating yielding to an increase of the linearity error.

<sup>17</sup> The condition must be fulfilled for all combinations of  $B_X$  and  $B_Y$ .

<sup>18</sup> Above 70 mT, the IMC® starts saturating yielding to an increase of the linearity error.

<sup>19</sup> Below 6 mT/mm, the performances are degraded due to a reduction of the signal-to-noise ratio, signal-to-offset ratio.

<sup>20</sup> IMC has better performance for concentrating in-plane (X-Y) field components, resulting in a better magnetic sensitivity. A correction factor, called IMC gain has to be applied to the Z field component to account for this difference.

<sup>21</sup> Higher values of Field too Low threshold are not recommended by Melexis and shall only been set in accordance with the magnetic design and taking a sufficient safety margin to prevent false positive.

Nominal performances apply when the useful signal  $\Delta B_{xz}/\Delta X$  and temperature range are inside the values defined in the following figure (fig. 9). At higher temperature or lower field gradients, the accuracy of MLX90374 is degraded and Limited Performances, described in section 8.3.2, apply.

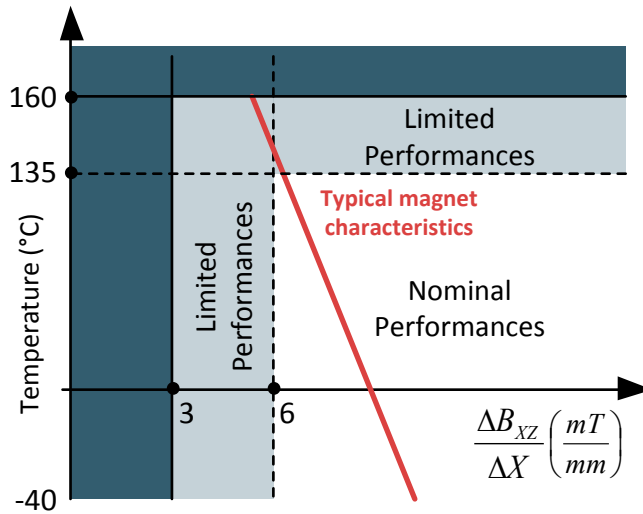

fig. 9 - Minimum useful signal definition for linear stray-field immune application

### 7.3. Standard/Legacy Mode (-300 code)

Parameter	Symbol	Min.	Typ.	Max.	Unit	Condition
Number of magnetic poles	$N_p$	-	2	-		
Magnetic Flux Density in X-Y plane	$B_x, B_y^{(17)}$			70	mT	$\sqrt{B_x^2 + B_y^2}$
Magnetic Flux Density in Z	$B_z$			100	mT	in absolute value
Useful Magnetic Flux Density Norm	$B_{Norm}$	$10^{(22)}$	20		mT	$\sqrt{B_x^2 + B_y^2}$ (X-y mode) $\sqrt{B_x^2 + \left(\frac{1}{G_{IMC}} B_z\right)^2}$ (X-Z mode) $\sqrt{B_y^2 + \left(\frac{1}{G_{IMC}} B_z\right)^2}$ (Y-Z mode) see 12.1.1 for sensing mode description.
IMC gain	$G_{IMC}$		1.19			see <sup>23</sup>
Magnet Temperature Coefficient	$TC_m$	-2400		0	$\frac{ppm}{^\circ C}$	

<sup>22</sup> Below 10 mT the performances are degraded due to a reduction of the signal-to-noise ratio, signal-to-offset ratio

<sup>23</sup> IMC has better performance for concentrating in-plane (X-Y) field components, resulting in a better overall magnetic sensitivity. A correction factor, called IMC gain has to be applied to the Z field component to account for this difference.

Parameter	Symbol	Min.	Typ.	Max.	Unit	Condition
Field Strength Resolution <sup>(24)</sup>	B <sub>Norm</sub>	0.075	0.100	0.125	$\frac{\text{mT}}{\text{LSB}}$	Magnetic field gradient norm expressed in 12bits words
Field Too Low Threshold <sup>(25)</sup>	B <sub>TH_LOW</sub>	0.4	4.0	<sup>(26)</sup>	mT	Typ is recommended value to be set by user
Field Too High Threshold <sup>(25)</sup>	B <sub>TH_HIGH</sub>	70	100 <sup>(27)</sup>	100 <sup>(27)</sup>	mT	Typ is recommended value to be set by user

Table 19 - Magnetic specifications for Standard application

Nominal performances apply when the useful signal B<sub>Norm</sub> is above the typical specified limit. Under this value, limited performances apply. See 8.4 for accuracy specifications.

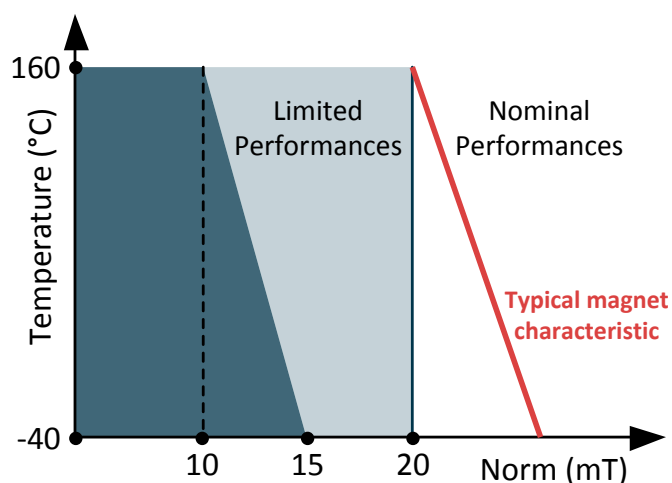

fig. 10 - Minimum useful signal definition for Standard/Legacy application

<sup>24</sup> Only valid with default MAGNET\_SREL\_T[1..7] configuration

<sup>25</sup> Typ. value is set by default for NVRAM rev.9 and shall be set by user for rev.8 (see Table 43, USER\_ID1 and Table 42)

<sup>26</sup> Higher values of Field too Low threshold are not recommended by Melexis and shall only be set in accordance with the magnetic design and taking a sufficient safety margin to prevent false positive.

<sup>27</sup> Due to the saturation effect of the IMC, the FieldTooHigh monitor detects only defects in the sensors

## 8. Accuracy Specifications

Accuracy specifications are valid for temperature range [-40;160] °C and supply voltage range [4.5 - 5.5] V unless otherwise noted.

### 8.1. Definition

This section defines several parameters, which will be used for the magnetic specifications.

#### 8.1.1. Intrinsic Linearity Error

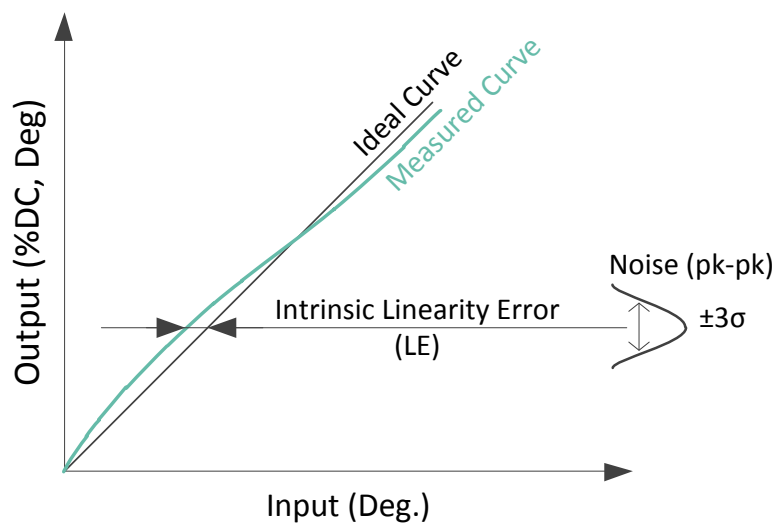

fig. 11 - Sensor accuracy definition

Illustration of fig. 11 depicts the intrinsic linearity error in new parts. The Intrinsic Linearity Error refers to the IC itself (offset, sensitivity mismatch, orthogonality) taking into account an ideal magnetic field. Once associated to a practical magnetic construction and the associated mechanical and magnetic tolerances, the output linearity error increases. However, it can be improved with the multi-point end-user calibration (see 12.2.6). As a consequence, this error is not critical in application because it is calibrated away.

#### 8.1.2. Total Angle Drift

After calibration, the output angle of the sensor might still change due to temperature change, aging, etc. This is defined as the total drift  $\partial\theta_{TT}$  :

$$\partial\theta_{TT} = \max\{\theta(\theta_{IN}, T, t) - \theta(\theta_{IN}, T_{RT}, t_0)\}$$

where  $\theta_{IN}$  is the input angle,  $T$  is the temperature,  $T_{RT}$  is the room temperature, and  $t$  is the elapsed lifetime after calibration.  $t_0$  represents the status at the start of the operating life. Note the total drift  $\partial\theta_{TT}$  is always defined with respect to angle at room temperature. In this datasheet,  $T_{RT}$  is typically defined at 35°C, unless stated otherwise. The total drift is valid for all angles along the full mechanical stroke.



## 8.2. Rotary Stray-field Immune (-100 code)

### 8.2.1. Nominal Performance

Valid before EoL calibration and for all applications under nominal performances conditions described in section 7.1 (fig. 8) and chapter 5.

Parameter	Symbol	Min	Typ	Max	Unit	Condition
XY - Intrinsic Linearity Error	$L_{E\_XY}$	-1		1	Deg.	
Noise <sup>(28)</sup>				0.2 0.4	Deg.	Filter = 2 Filter = 0 <sup>(29)</sup>
XY - Total Drift <sup>(30)</sup>	$\partial\theta_{TT\_XY}$	-0.85		0.85	Deg.	Relative to 35°C
Hysteresis			0.1		Deg.	
Output Stray Field Immunity	$\partial\theta_{FF}$			0.6	Deg.	with 10mT/mm useful gradient field and 4kA/m stray-field <sup>(31)</sup>

Table 20 - Rotary stray-field immune magnetic performances

### 8.2.2. Limited Performances

Valid before EoL calibration and for all applications under limited performances conditions described in section 7.1 (fig. 8) and chapter 5.

Parameter	Symbol	Min	Typ	Max	Unit	Condition
XY - Intrinsic Maximum Error	$L_E$	-1		1	Deg.	
Noise <sup>(28)</sup>				0.7 0.5 0.35	Deg.	Filter = 0 Filter = 1 Filter = 2
XY - Total Drift <sup>(30)</sup>		-0.85		0.85	Deg.	Relative to 35°C
Hysteresis			0.1		Deg.	

Table 21 - Rotary stray-field immune limited magnetic performances

<sup>28</sup>  $\pm 3\sigma$

<sup>29</sup> See section 12.2.3 for details concerning Filter parameter

<sup>30</sup> Verification done on new and aged devices in an ideal magnetic field gradient (see 8.1.2). An additional application-specific error arises from the non-ideal magnet and mechanical tolerance drift.

<sup>31</sup> Tested in accordance with ISO 11452-8:2015, at 30°C, with stray-field strength of 4kA/m from any direction. This error scales linearly with both the useful field and the disturbing field.

## 8.3. Linear Stray-field Immune Mode (-200 code)

### 8.3.1. Nominal Performances

Valid before EoL calibration and for all applications under nominal conditions described in section 7.2 (fig. 9) and chapter 5.

Parameter	Symbol	Min	Typ	Max	Unit	Condition
XZ - Intrinsic Maximum Error	$L_{E\_XZ}$	-2.5	$\pm 1.25$	2.5	Deg.	
Noise <sup>(28)</sup>			0.10	0.20		Filter = 1, 6mT/mm
			0.15	0.30	Deg.	Filter = 0, 6mT/mm
			-	0.25		Filter = 0, 6mT/mm, $T_{max}=125^{\circ}C$
XZ - Total Drift <sup>(30)</sup>	$\partial\theta_{TT\_XZ}$	-0.8		0.8	Deg.	Compared to 35°C, 6mT/mm gradient field
Hysteresis				0.10	Deg.	
Output Stray Field Immunity	$\partial\theta_{FF}$			0.8	Deg.	For 6mT/mm gradient field and 4kA/m stray-field <sup>(31)</sup>

Table 22 - Linear stray-field immune magnetic performances

### 8.3.2. Limited Performances

Valid before EoL calibration and for all applications under limited performances conditions described in section 7.2 (fig. 9) and chapter 5.

Parameter	Symbol	Min	Typ	Max	Unit	Condition
XZ - Intrinsic Maximum Error	$L_E$	-4	$\pm 2$	4	Deg.	
Noise <sup>(28)</sup>			0.20	0.40		Filter = 1, 3mT/mm
			0.25	0.65	Deg.	Filter = 0, 3mT/mm
			-	0.45		Filter = 0, 3mT/mm, $T_{max}=125^{\circ}C$
XZ - Total Drift <sup>(30)</sup>	$\partial\theta_{TT\_XZ}$	-1.4		1.4	Deg.	Compared to 35°C, 3mT/mm
Hysteresis				0.25	Deg.	3mT/mm

Table 23 - Linear stray-field immune limited magnetic performances

## 8.4. Standard/Legacy Mode (-300 code)

### 8.4.1. Nominal Performances

Valid before EoL calibration and for all applications under nominal conditions described in section 7.3 (fig. 10) and chapter 5.

Parameter	Symbol	Min	Typ	Max	Unit	Condition
XY - Intrinsic Linearity Error	$L_{E\_XY}$	-1		1	Deg.	
XZ - Intrinsic Linearity Error	$L_{E\_XZ}$	-2.5	$\pm 1.25$	2.5	Deg.	
YZ - Intrinsic Linearity Error	$L_{E\_YZ}$	-2.5	$\pm 1.25$	2.5	Deg.	
Noise <sup>(32)</sup>			0.05	0.1		Filter = 0, 40mT
			0.1	0.2	Deg.	Filter = 0, 20mT
			0.05	0.1		Filter = 2
XY - Total Drift <sup>(33)</sup>	$\partial\theta_{TT\_XY}$	-0.45		0.45	Deg.	Relative to 35°C
XZ - Total Drift <sup>(33)</sup>	$\partial\theta_{TT\_XZ}$	-0.6		0.6	Deg.	Relative to 35°C
YZ - Total Drift <sup>(33)</sup>	$\partial\theta_{TT\_YZ}$	-0.6		0.6	Deg.	Relative to 35°C
Hysteresis			0.05	0.1	Deg.	20mT

Table 24 - Standard Mode Nominal Magnetic Performances

### 8.4.2. Limited Performances

Valid before EoL calibration and for all applications under limited performances conditions described in section 7.3 (fig. 10) and chapter 5.

Parameter	Symbol	Min	Typ	Max	Unit	Condition
XY - Intrinsic Linearity Error	$L_{E\_XY}$	-1		1	Deg.	
XZ - Intrinsic Linearity Error	$L_{E\_XZ}$	-2.5	$\pm 1.25$	2.5	Deg.	
YZ - Intrinsic Linearity Error	$L_{E\_YZ}$	-2.5	$\pm 1.25$	2.5	Deg.	
Noise <sup>(32)</sup>			0.2	0.4		Filter = 0
			0.14	0.28	Deg.	Filter = 1
			0.1	0.2		Filter = 2
XY - Total Drift <sup>(33)</sup>	$\partial\theta_{TT\_XY}$	-0.6		0.6	Deg.	Relative to 35°C
XZ - Total Drift <sup>(33)</sup>	$\partial\theta_{TT\_XZ}$	-0.8		0.8	Deg.	Relative to 35°C
YZ - Total Drift <sup>(33)</sup>	$\partial\theta_{TT\_YZ}$	-0.8		0.8	Deg.	Relative to 35°C
Hysteresis			0.1	0.2	Deg.	10mT

Table 25 - Standard Mode Limited Magnetic Performances

<sup>32</sup>  $\pm 3\sigma$

<sup>33</sup> Verification done on new and aged devices in an ideal magnetic field (see 8.1.2). An additional application-specific error arises from the non-ideal magnet and mechanical tolerance drift.

## 9. Memory Specifications

Parameter	Symbol	Min	Typ	Max	Unit	Note
ROM	ROMsize		32		kB	1 bit parity check (single error detection)
RAM	RAMsize		1024		B	1 bit parity check (single error detection)
NVRAM	NVRAMsize		256		B	6 bits ECC (single error correction, double error detection)

*Table 26 - Memory Specifications*

## 10. Digital output protocol

### 10.1. PWM (pulse width modulation)

#### 10.1.1. Definition

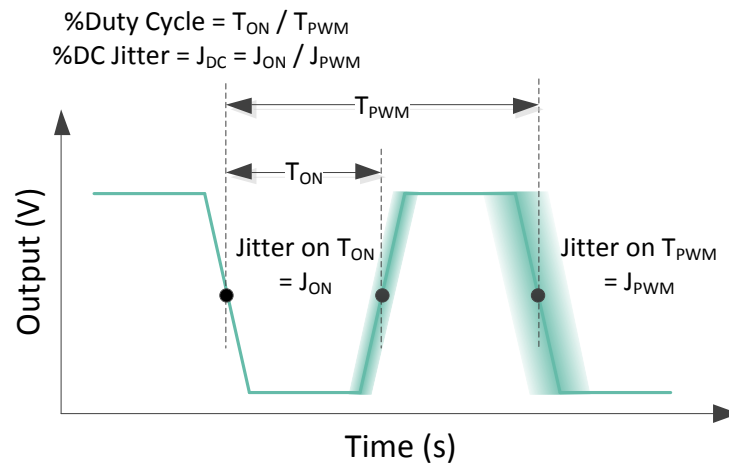

fig. 12 - PWM Signal definition

Parameter	Symbol	Test Conditions
PWM period	$T_{P_{PWM}}$	Trigger level = 50% $V_{DD}$
Rise time, Fall time	$t_{rise}, t_{fall}$	Between 20% and 80% of $V_{DD}$ , see Table 12 for values
Jitter	$J_{ON}$ $J_{P_{PWM}}$	$\pm 3\sigma$ for 1000 successive acquisitions with clamped output
Duty Cycle	DC	$T_{ON} / T_{P_{PWM}}$

Table 27 - PWM Signal definition

#### 10.1.2. PWM performances

Parameter	Symbol	Min	Typ	Max	Unit	Condition
PWM Output Resolution	$R_{pwm}$		0.024	0.051	%DC/LSB	2kHz. Worst case error for 160°C
PWM %DC Jitter	$J_{DC}$			0.03	%DC	Push-Pull, 2kHz, $C_L=10nF, R_{LPU}=4.7k\Omega$
PWM Period Jitter	$J_{pwm}$	-	-	300	ns	Push-Pull, 2kHz, $C_L=10nF, R_{LPU}=4.7k\Omega$
PWM %DC thermal drift			0.02	0.05	%DC	Push-Pull, 2kHz, $C_L=10nF, R_{LPU}=4.7k\Omega$

Table 28 - PWM Signal Specifications

## 10.2. Single Edge Nibble Transmission (SENT) SAE J2716

The MLX90374 can be configured to provide a digital output signal compliant with SAE J2716 Revised APR2016.

### 10.2.1. Sensor message definition

The MLX90374 repeatedly transmits a sequence of pulses, corresponding with a sequence of nibbles (4 bits), with the following sequence:

- Calibration/Synchronization pulse period 56 clock ticks to determine the time base of the SENT frame
- One 4 bits Status and Serial Communication nibble pulse
- A sequence of one up to six 4 bits data nibble pulses representing the values of the signal(s) to be transmitted. The number of nibbles will be fixed for each application of the encoding scheme (i.e. Single Secure sensor format A.3, Throttle positions sensor A.1)
- One 4 bits Checksum nibble pulse
- One optional pause pulse

See also SAE J2716 APR2016 for general SENT specification.

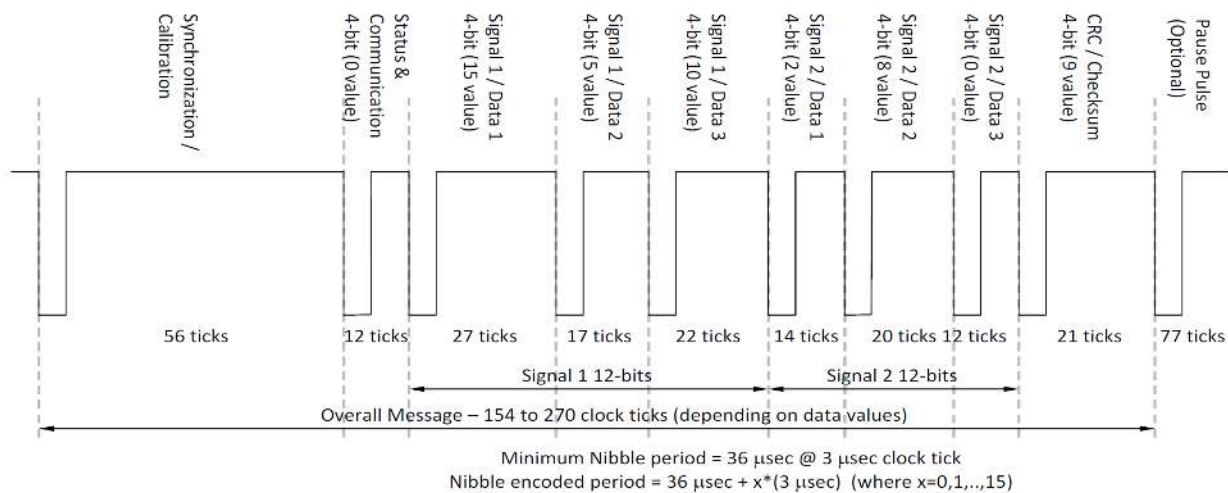

fig. 13 - SENT message encoding example for two 12bits signals

### 10.2.2. Sensor message frame contents

The MLX90374 SENT transmits a sequence of data nibbles, according to the following configurations:

Description	Symbol	Min	Typ	Max	Unit	Description
SENT	SENTrev		2010	2016		SENT revision. Supports enhanced serial channel messages (2016)
Clock tick time	tickTime	1	3	12	µs	Main use cases : Fast SENT, 1.5µs tick time Normal SENT, 3µs tick time Slow SENT, 6µs tick time (see section 6.5)
Number of data nibbles	Xdn	3	6			
Frame duration (no pause pulse)	Npp	154		270	ticks	6 data nibbles
Frame duration with pause pulse	Ppc	282	320	922	ticks	Valid for 3µs tick time
Sensor type	A.1 A.3					Dual Throttle Position sensors Single Secure sensors

Table 29 - SENT Protocol Frame Definition

### 10.2.3. Single secure sensor A.3

The MLX90374 SENT transmits a sequence of data nibbles; according single secure sensor format defined in SAE J2716 appendix A.3. The frame contains 12-bit angular value, a 8 bits rolling counter and an inverted copy of the most significant nibble of angular value. This format is activated when SENT\_SS bit is set to 1 (see Table 42, #137)

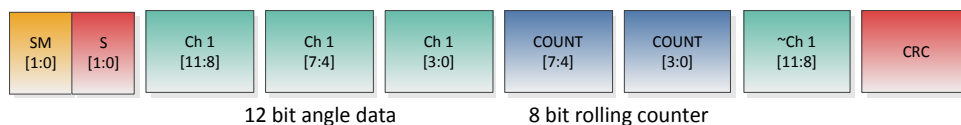

fig. 14 - A.3 Single Secure Sensor Frame Format

Shorthand Description	Tick time	Data nibbles	Pause Pulse	Serial message	Data format
SENT2010-03.0us-6dn-ppc(366.0)-esp-A.3	3 us	6	Y	Enhanced	A.3
SENT2010-03.0us-6dn-ppc(366.0)-nsp-A.3	3 us	6	Y	None	A.3
SENT2010-03.0us-6dn-npp-nsp-A.3	3 us	6	N	None	A.3
SENT2010-##-#us-#dn-###()-###-A.3	1..12	6	Y/N	En/None	A.3

Table 30 - A.3 Single Secure Sensor Shorthand examples

### 10.2.4. Dual Throttle position sensor A.1

The MLX90374 SENT transmits a sequence of data nibbles; according dual throttle positions sensor defined in SAE J2716 appendix A.1. The frame contains two 12-bit angular values.



fig. 15 - A.1 Dual Throttle Position Sensor Frame Format

Shorthand Description	Tick time	Data nibbles	Pause Pulse	Serial message	Data format
SENT2010-03.0us-6dn-ppc(366.0)-esp-A.1	3 us	6	Y	Enhanced	A.1
SENT2010-03.0us-6dn-ppc(366.0)-nsp-A.1	3 us	6	Y	None	A.1
SENT2010-03.0us-6dn-npp-nsp-A.1	3 us	6	N	None	A.1
SENT2010-##-#us-#dn-###()-###-A.1	1..12	6	Y/N	En/None	A.1

Table 31 - A.1 Dual Throttle Position Sensor Shorthand Examples

Second fast channel configuration:

SENT_FAST_CHANNEL_2	CH2 configuration (ABB revision)	CH2 configuration (ABC revision)
0	Temperature sensor (SP ID 0x23)	Temperature sensor (SP ID 0x23)
1	0xFF9(d4089) - CH1	Second Output (see 12.3)
2	RAM data (RAMPROBE_PTR)	RAM data (RAMPROBE_PTR)
3	0xFFF(d4095) - CH1	0xFFF(d4095) - CH1

Table 32 - A.1 Dual Throttle Position Sensor Fast Channel 2 configuration

### 10.2.5. Start-up behaviour

The circuit will start to send initialisation frames once digital start-up is done but angle measurement initialisation sequence is not yet complete. These initialisation frames content can be chosen by user with the following option:

SENT_INIT_GM	Initialisation frame value	Comments
0	0x000	SAE compliant
1	0xFFF	OEM requirement

Table 33 - Initialisation Frame Content Definition



### 10.2.6. SENT Output Timing configuration

SENT_TICK_TIME	Tick time configuration	Description
0	3 $\mu$ s	Standard SENT
1	0.5 $\mu$ s	Not recommended
2	1 $\mu$ s	Not recommended
3	1.5 $\mu$ s	Fast SENT
4	2.0 $\mu$ s	Not recommended
5	2.5 $\mu$ s	Not recommended
6	6 $\mu$ s	Slow SENT
7	12 $\mu$ s	Not recommended

Table 34 - SENT Tick Time Configuration

SENT_SEL_SR_FALL	Fall time ( $T_{fall}$ )
0	No slew rate control
1	0.7 $\mu$ s
2	1.2 $\mu$ s
3	1.9 $\mu$ s
4	4.8 $\mu$ s
5	9.6 $\mu$ s
6	19 $\mu$ s
7	24 $\mu$ s

SENT_SEL_SR_RISE	Rise Time ( $T_{rise}$ )
0	No slew rate control
1	0.9 $\mu$ s
2	1.6 $\mu$ s
3	3.0 $\mu$ s
4	6.2 $\mu$ s
5	12 $\mu$ s
6	24 $\mu$ s
7	30 $\mu$ s

Table 35 - SENT Rise and Fall Times Configuration

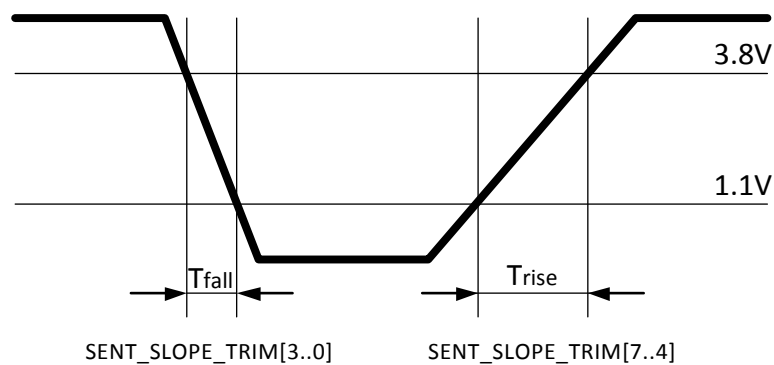

fig. 16 - SENT Rise and Fall Times configuration

NIBBLE_PULSE_CONFIG	High/low time configuration
2	Fixed low time (5 ticks)
3	Fixed high time (6 ticks) <sup>(34)</sup>

Table 36 - SENT Nibble configuration (high/low times)

### 10.2.7. Serial message channel (slow channel)

Serial data is transmitted serial in bit number 3 and 2 of the status and communication nibble. A serial message frame stretches over 18 consecutive SENT data messages from the transmitter. All 18 frames must be successfully received (no errors, calibration pulse variation, data nibble CRC error, etc.) for the serial value to be received.

Enhanced format with 12-bits data and 8-bits message ID is used (SAE J2716 APR2016 5.2.4.2, fig. 5.2.4.2-2). According to the standard, SM[0] contains a 6bits CRC followed by a 12-bits data. Message content is defined by a 8-bit message ID transmitted in the SM[1] channel. Correspondence between ID and message content is defined in the tables below (Table 37, Table 38 and Table 39).

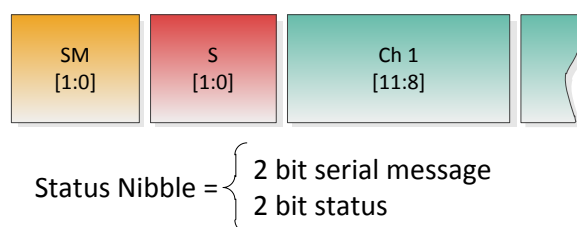

fig. 17 - SENT Status Nibble and Serial Message

By default, the short sequence consisting of a cycle of 24 data is transmitted (Table 37). An extended sequence can be used through configuration of SENT\_SLOW\_EXTENDED (Table 38). Additionally, the norm of the B field detected by the sensor can be returned at the end of the sequence by setting SENT\_SLOW\_BFIELD (Table 39).

#	8bit ID	Item	Source data
1	0x01	Diagnostic error code	Current status code from RAM
2	0x06	SENT standard revision	SENT_REV from NVRAM
3	0x01	Diagnostic error code	Current status code from RAM
4	0x05	Manufacturer code	SENT_MAN_CODE from NVRAM
5	0x01	Diagnostic error code	Current status code from RAM
6	0x03	Channel 1 / 2 Sensor type	SENT_SENSOR_TYPE from NVRAM
7	0x01	Diagnostic error code	Current status code from RAM
8	0x07	Fast channel 1: X1	SENT_CHANNEL_X1 from NVRAM
9	0x01	Diagnostic error code	Current status code from RAM

<sup>34</sup> When using fixed high time in normal SENT mode, Melexis recommends lowering SENT\_SEL\_SR\_RISE to 3 or setting ABE\_OUT\_MODE to 2 to two to avoid potential timing degradation on short nibbles.

#	8bit ID	Item	Source data
10	0x08	Fast channel 1: X2	SENT_CHANNEL_X2 from NVRAM
11	0x01	Diagnostic error code	Current status code from RAM
12	0x09	Fast channel 1: Y1	SENT_CHANNEL_Y1 from NVRAM
13	0x01	Diagnostic error code	Current status code from RAM
14	0x0A	Fast channel 1: Y2	SENT_CHANNEL_Y2 from NVRAM
15	0x01	Diagnostic error code	Current status code from RAM
16	0x23	(Internal) temperature	Current temperature from RAM
17	0x01	Diagnostic error code	Current status code from RAM
18	0x29	Sensor ID #1	SENT_SENSOR_ID1 from NVRAM
19	0x01	Diagnostic error code	Current status code from RAM
20	0x2A	Sensor ID #2	SENT_SENSOR_ID2 from NVRAM
21	0x01	Diagnostic error code	Current status code from RAM
22	0x2B	Sensor ID #3	SENT_SENSOR_ID3 from NVRAM
23	0x01	Diagnostic error code	Current status code from RAM
24	0x2C	Sensor ID #4	SENT_SENSOR_ID4 from NVRAM

*Table 37 - SENT Slow Channel Standard Data Sequence*

#	8bit ID	Item	Source data
25	0x01	Diagnostic error code	Current status code from RAM
26	0x90	OEM Code #1	SENT_OEM_CODE1 from NVRAM
27	0x01	Diagnostic error code	Current status code from RAM
28	0x91	OEM Code #2	SENT_OEM_CODE2 from NVRAM
29	0x01	Diagnostic error code	Current status code from RAM
30	0x92	OEM Code #3	SENT_OEM_CODE3 from NVRAM
31	0x01	Diagnostic error code	Current status code from RAM
32	0x93	OEM Code #4	SENT_OEM_CODE4 from NVRAM
33	0x01	Diagnostic error code	Current status code from RAM
34	0x94	OEM Code #5	SENT_OEM_CODE5 from NVRAM
35	0x01	Diagnostic error code	Current status code from RAM
36	0x95	OEM Code #5	SENT_OEM_CODE6 from NVRAM
37	0x01	Diagnostic error code	Current status code from RAM
38	0x96	OEM Code #5	SENT_OEM_CODE7 from NVRAM
39	0x01	Diagnostic error code	Current status code from RAM
40	0x97	OEM Code #8	SENT_OEM_CODE8 from NVRAM

*Table 38 - SENT Slow Channel Extended Data Sequence*

#	8bit ID	Item	source data
25	0x80	Field Strength	Bfield_norm from RAM (standard sequence)
41	0x80	Field Strength	Bfield_norm from RAM (extended sequence)

Table 39 - SENT Slow Channel Magnetic Field Norm ID and position

For Field Strength encoding, see chapter 7, Magnetic Field Specifications, under the section corresponding to the selected application.

### 10.2.8. Serial Message Error Code

The list of error and status messages transmitted in the 12-bit Serial Message data field when Serial Message 8-bit ID is 0x01, is given in the Table 40. The error is one-hot encoded and therefore each bit is linked to one or several monitor. Only the first error detected is reported and serial message error code will not be updated until all the errors have disappeared. This mechanism ensures only one error at a time takes control of the error debouncing counter (see 12.4.2).

The MSB acts as an error Flag when SENT\_DIAG\_STRICT is set. This bit will be high only when an error is present. For compatibility with previous Triaxis®, this bit can be kept high even if no error is present (SENT\_DIAG\_STRICT = 0).

Bit Nb	12 Bit Data (hex)	Diagnostic	Comments
-	0x000 / 0x800	No error	Programmable (SENT_DIAG_STRICT, see Table 42, no 151)
0	0x801	GainOOS	Gain out of spec (see GAIN_MIN, GAIN_MAX)
1	0x802	FieldTooLow	Fieldstrength below defined low threshold (see Table 42, no 103)
2	0x804	FieldTooHigh	Fieldstrength above defined high threshold (see Table 42, no 104)
3	0x808	ADCclip	ADC is saturated, either low or high
4	0x810	ADC_test	ADC wrong conversion
5	0x820	Analog Supply Monitors	Detects VDDA (VDEC) over and under voltage or VDD under voltage
6	0x840	Digital Supply Monitors	Detects VDDD (1.8V internal digital supply) overvoltage
7	0x880	RoughOffset	Hall Element offset monitor
8	0x900	Over/Under Temp	Temperature sensor monitor (see 12.4.3)
9	0xA00	HE_Bias / Analog Front End	Hall Element biasing issue / Analog front end self-test <sup>(35)</sup>

<sup>35</sup> Only available on MLX90374 ABC version (not on ABB)

Bit Nb	12 Bit Data (hex)	Diagnostic	Comments
10	0xC00	Suply Bias Current	Current biasing system monitor
11	0x800	Extra Error Flag	set to one if any error present (only when SENT_DIAG_STRICT = 1). Otherwise, always high.

Table 40 - SENT Serial Message Error Code

### 10.2.9. SENT configuration shorthand definition

Shorthand description	Format	Req	90374 programmable setting
SENT SAE J2716 Rev	SENT xxxx	2007	<b>CRC_2007</b>
		2008	0 > 2007
		2010	1 2007
		2016	
Clock Tick length [μs]	XX.X μs	0.5<xx<12	<b>SENT_TICK_TIME</b>
			0 SENT 3.0μs
			1 SENT 0.5μs
			2 SENT 1μs
			3 SENT 1.5μs
			4 SENT 2.0μs
			5 SENT 2.5μs
			6 SENT 6.0μs
7 SENT 12.0μs			
Number of data Nibbles	X dn	3 ≤ x ≤ 6	<b>EN_FAST_CH2</b>
			0 3 Data nibbles 1 6 Data nibbles
Pause Pulse Option	npp ppc (xxx.0)	No pause Pulse Pause Pulse with const. frame length	<b>PROTOCOL</b>
			0 = npp 2 = ppc
			<b>T_FRAME</b> xxx > 282...922
Use of Serial protocol	nsp ssp esp	No serial protocol Short serial protocol Enhanced serial protocol	<b>SERIAL_CONFIG</b>
			1 nsp 2 ssp (not compliant) 3 esp
Sensor type	A.1 A.3	Dual Throttle Position sensor Single secure sensor	<b>SENT_SS</b>
			0 A.1 1 A.3

Table 41 - SENT Shorthand Description

## 11. End-User Programmable Items

Parameter	PSF value	Description	Default Values	
			Standard	#bits
<b>GENERAL CONFIGURATION</b>				
USER_ID[0..5]	1..6	User Id. Reference. Reserved for customer traceability	see 11.1	6 x 8
MEMLOCK	179	Disable NVRAM write (memory LOCK)	0	2
WARM_ACT_HIGHV	238	Enable battery application ( $V_{DD} > 5\text{ V}$ )	0	1
WARM_TRIGGER_LONG	174	Add delay to enter PTC mode (MT7V)	0	1
<b>SENSOR FRONT-END</b>				
MAGNET_SREL_T[1..7]	7..13	Magnet Relative sensitivity at temperature Tx <sup>(36)</sup>	255	8
GAINMIN	14	Low threshold for virtual gain	01	8
GAINMAX	15	High threshold for virtual gain	63	8
GAINSATURATION	26	Gain Saturates on GAINMIX and GAINMAX	0	1
<b>Mapping fields for output angle</b>				
SENSING_MODE	18	Rotary stray field Immune -- order code 100	0	3
		Linear position stray field Immune -- order code 200	4	
		Linear position / Angular Rotary -- order code 300	1-3	
DSP_NB_CONV <sup>(37)</sup>	19	Number of phase spinning within ADC sequence 0=4 phase spinning	0 <sup>(37)</sup>	2
EN_USER_FE_TRIMMING	125	Enable Additional Virtual Offset	0	1
B_OFS_1	161	Virtual Offset on component B1 (Warning! if used overwrites USERID[2] and USERID[3])	0	16
B_OFS_2	163	Virtual Offset on component B2 (Warning! if used overwrites USERID[4] and USERID[5])	0	16
<b>DSP – FILTERING</b>				
FILTER	21	Filter mode selection	1	2
HYST	16	Hysteresis threshold for EMA (IIR) filter	0	8
DENOISING_FILTER_ALPHA_SEL	95	Select the alpha parameter of the EMA (IIR) filter	0	2
<b>DSP – ANGLE MAPPING FUNCTIONS</b>				
CW	20	Set rotation to clockwise	0	1
DP	27	Discontinuity point	0	16
WORK_RANGE_GAIN	217	Re-scaling before the piece-wise linearization step	16	8
WORKING_RANGE	23	17, 32pts - Output angle range (= limited selection of WORK_RANGE_GAIN)	0	3
4POINTS	22	Select LNR method 4 pts	0	1

<sup>36</sup> This parameter is mainly intended to be used in Linear Hall mode (no IMC) or with Virtual Offset. It is strongly recommended to keep default values.

<sup>37</sup> Changing default value could impact the safety metrics. Default value shall be used.

Parameter	PSF value	Description	Default Values	
			Standard	#bits
DSP_LNR_RESX2	94	Enable a double resolution LNR method 0: 4-points or 16-segments 1: 8-points or 32-segments	0	1
GAIN_ANCHOR_MID	225	re-scaling before the piece-wise linearization step	1	1
LNRS0, LNRAS.. LNRDS		4pts –Slope for reference points A, B, C, D	N/A	16
LNRRAX, LNRBX.. LNRDX		4pts - X Coordinate for reference points A, B, C, D	N/A	16
LNRRAY, LNRBY.. LNRDY		4pts - Y Coordinate for reference points A, B, C, D	N/A	16
LNRY0..Y16		17 pts - Y coordinate point 0..16	1-4088	16
LNRR0..X7		8 pts - X coordinate point 0..7	N/A	16
LNR_DELTA_Y01..Y32	192.. 223	Delta Y for 32-segment linearization	0..255	8
LNR_DELTA_Y_EXPAND_LOG2	97	Adjust the span of LNR_DELTA_Yn parameters	0	2
USEROPTION_SCALING	24	Enables the output scaling function (x2) 0 = [0..100%] 1 = [-50..150%]	1	1
CLAMPLOW	87	Low clamping value of angle data	3277	16
CLAMPHIGH	88	High clamping value of angle data	62259	16
CLAMP2_EN <sup>(38)</sup>	244	Enable specific OUT2 clamping	1	1
CLAMPLOWOUT2 <sup>(38)</sup>	241	Specific low clamping value for OUT2 data	3277	16
CLAMPHIGHOUT2 <sup>(38)</sup>	242	Specific high clamping value for OUT2 data	62259	16
OUT2SLOPERATIO <sup>(38)</sup>	245	Relative angle working range between both outputs	61440	16
OUT2OFFSET <sup>(38)</sup>	247	Relative angle reference between both outputs	8191	1
OUTSLOPE_SEL <sup>(38)</sup>	246	Select temperature-dependent offset (see 12.2.8)	0	2
OUTSLOPE_COLD <sup>(38)</sup>	253	Slope coefficient at cold of the programmable temperature-dependent offset (signed value)	0	8
OUTSLOPE_HOT <sup>(38)</sup>	254	Slope coefficient at Hot of the programmable temperature-dependent offset (signed value)	0	8

### DIAGNOSTICS

DIAG_TEMP_THR_LOW <sup>(37)</sup>	101	Temperature threshold for under-temperature diagnostic	8 <sup>(37)</sup>	8
DIAG_TEMP_THR_HIGH <sup>(37)</sup>	102	Temperature threshold for over-temperature diagnostic	136 <sup>(37)</sup>	8
DIAG_FIELDTOLOWTHRES	103	Field limit under which a fault is reported. <b>On revision ABB, need to be programmed by user to be active.</b> Each LSB of this threshold corresponds to 4 LSB of the field strength.	<sup>(39)</sup>	8

<sup>38</sup> Only available on ABC revision

<sup>39</sup> Default value depends on application and IC revision. See chapter 7 tables for more information.

Parameter	PSF value	Description	Default Values	
			Standard	#bits
DIAG_FIELDTOOHIGHTHRES	104	Field limit over which a fault is reported. Each LSB of this threshold corresponds to 4 LSB of the field strength.	255	8
PWM_WEAKMAGTHRESH	105	Weak Magnet threshold Byte (PWM only)	0	8
DIAGDEBOUNCE_STEPDOWN	107	Diagnostic debouncing stepdown time	1	4
DIAGDEBOUNCE_STEPUP	108	Diagnostic debouncing step-up time	2	4
DIAGDEBOUNCE_THRESH	110	Diagnostic debouncing threshold	2	6
DIAG_EN <sup>(37)</sup>	111	Diagnostics global enable. <b>Do not modify!</b> (see 13.2 Safety Mechanisms)	1 <sup>(37)</sup>	1
COLD_SAFE_STARTUP_EN	112	Normal (0) or full safe (1) start-up after power-on reset (see 6.3.1)	0	1
OUT_DIAG_HIZ_TIME	177	Duration of output High-Z after transient digital fault, <b>do not modify!</b>	-	3

### OUTPUT CONFIGURATION

PROTOCOL	114	Select digital output communication mode 0 = SENT without pause pulse 1 = PWM (default) 2 = SENT with pause	1	2												
PWM_OUT_MODE <sup>(38)</sup>	251	Diagnostic reporting mode for dual PWM signals <table border="1" data-bbox="635 1055 1286 1256"> <thead> <tr> <th></th> <th>OUT1</th> <th>OUT2</th> </tr> </thead> <tbody> <tr> <td>0</td> <td>Fault Duty Cycle</td> <td>1-Fault Duty Cycle</td> </tr> <tr> <td>1</td> <td>Angle Value</td> <td>1-Fault Duty Cycle</td> </tr> <tr> <td>2</td> <td>Fault Duty Cycle</td> <td>OUT2 Angle Value</td> </tr> </tbody> </table> When OUT2 is in Kickdown mode, OUT1 always reports the fault Duty Cycle		OUT1	OUT2	0	Fault Duty Cycle	1-Fault Duty Cycle	1	Angle Value	1-Fault Duty Cycle	2	Fault Duty Cycle	OUT2 Angle Value	0	2
	OUT1	OUT2														
0	Fault Duty Cycle	1-Fault Duty Cycle														
1	Angle Value	1-Fault Duty Cycle														
2	Fault Duty Cycle	OUT2 Angle Value														
PWM2_EN	115	Enables the second PWM Output	1	1												
OUT_ALWAYS_HIGHZ	119	Forces primary output (SENT/PWM) to high-Z mode	0	1												
TWO_ANGLES_FRAME	138	Enable 2 angle measurements per period in synchronous mode (SENT w/ pause pulse)	1	1												
NIBBLE_PULSE_CONFIG	233	SENT nibble high/low-time configuration 2 = Fixed 5 ticks low 3 = Fixed 6 ticks high	2	2												
T_FRAME	147	SENT Frame Tick Count / PWM period (4µs/LSB). <b>! Has impact on the analog diagnostics DCT</b> (see Table 9 - General Timing Specifications)	250	12												
T_SYNC_DELAY <sup>(37)</sup>	150	SENT - ADC synchronization delay	21 <sup>(37)</sup>	12												
ABE_OUT_MODE	175	Output physical configuration 00: SENT mode = digital push-pull 01: SENT mode = open-drain 10: PWM mode = digital fast push-pull 11: PWM open-drain	0	2												
SENT_SEL_SR_FALL	255	SENT/PWM slope fall time configuration (see Table 35)	4	3												



Parameter	PSF value	Description	Default Values	
			Standard	#bits
SENT_SEL_SR_RISE	256	SENT/PWM slope rise time configuration (see Table 35)	4	3
ABE_OUT_CFG	176	Output pin configuration, <b>do not modify!</b>	0	2
ROUT_LOW	178	Option for output pull-up resistor 0: > 200 Ohms 1: < 200 Ohms	1	1

### SWITCH FUNCTIONS

KICKDOWN_EN	190	Enable the switch function on OUT2 (ABB version)	0	1
KICKDOWN_EN <sup>(38)</sup>	190	Switch configuration for ABC revision 0 = no switch function 1 = Switch1 on Test output 2 = Switch1 on OUT2 3 = Switch1 on OUT2, Switch2 on Test output	0	2
KICKDOWN_POL	189	0: Normal polarity (kickdown=1 if input>threshold) 1: Inverted polarity (kickdown=1 if input<threshold)	0	1
KICKDOWN_THRES_UP	187	Switch1 threshold	255	12
KICKDOWN_THRES_HYST	188	Switch1 hysteresis	3	2
KICKDOWN_THRES_UP2 <sup>(38)</sup>	249	Switch2 threshold	255	12
KICKDOWN_THRES_HYST2 <sup>(38)</sup>	250	Switch2 hysteresis	3	2

### PWM PROTOCOL OPTIONS

PWM_POL	116	Invert the PWM polarity	0	1
PWM_SRC	117	For debugging purpose only: <b>do not change!</b>	0	1
PWM_REPORT_MODE_ANA	118	Error message within PWM frame 0x0: PWM - config 2 (PWM signal in fault band) 0x1: PWM - config 1 (HiZ) 0x2: Output = config 3.a (0 constant) 0x3: Output = config 3.b (1 constant)	N/A	2
PWM_DC_FAULT	120	PWM Duty Cycle in case of Fault	4	8
PWM_DC_FIELDTOLOW	121	PWM Duty Cycle in case of Field Strength Too Low	10	8
PWM_DC_WEAKMAG	122	PWM Duty Cycle in case of Weak Magnet	6	8

### SENT PROTOCOL OPTIONS

STATUS_IN_CRC	124	Add first nibble in SENT CRC calculation	0	1
EN_FAST_CH2	126	Enable SENT fast channel two	1	1
SENT_CH1_SRC_SEL <sup>(37)</sup>	127	Selection of the SENT channel 1 source: 0: Angle 1: RAM data at addr SENT_CH2_PTR	0 <sup>(37)</sup>	1
RAMPROBE_PTR	129	Data to be transmitted in SENT channel 2	0	16
SENT_MAN_CODE	131	Serial data message Manufacturer code	6	12
SENT_REV	132	Serial data message SENT rev (same as SENT_SLOW_MESSAGE_0)	4	12
SENT_SENSOR_TYPE	134	Serial data message SENSOR_TYPE	0x050	12

Parameter	PSF value	Description	Default Values	
			Standard	#bits
SENT_TICK_TIME <sup>(37)</sup>	136	SENT tick time	0 <sup>(37)</sup>	3
SENT_SS	137	Enable Single Secure sensor format A.3	1	1
SENT_SLOW_EXTENDED	139	Enable enhanced serial message ID OEM code 25-40	0	1
SENT_FAST_CHANNEL_2	141	Configuration channel 2 if NV_SENT_SS=0	2	2
SENT_LEGACY_CRC	142	Enable SENT2007 CRC calculation	0	1
SENT_SLOW_BFIELD	143	Enable enhanced serial message ID 80	0	1
SENT_REPORT_MODE_ANA	144	Error message within SENT frame in diagnostic mode: 0x0: SENT - Status bit S0 is set 0x1: SENT - Status bit S0 is set and data = FF9 + DIAG_FAULT_CODE (FFF by default) 0x2: SENT - Status bit S0 is set and the redundant nibble is inverted	0	2
SENT_DIAG_STRICT	151	Enhanced serial error reporting option: Disable Bit 11 when no error is present.	1	1
SENT_CHANNEL_X1	152	Serial data message X1	0	12
SENT_CHANNEL_X2	153	Serial data message X2	0	12
SENT_CHANNEL_Y1	155	Serial data message Y1	0	12
SENT_CHANNEL_Y2	157	Serial data message Y2	0	12
SENT_SENSOR_ID1.4	159.. 164	Serial data message sensor ID1.. ID4	0	12
SENT_OEM_CODE1..8	165.. 172	Serial data message OEM code 1..8	0	12
SERIAL_CONFIG	234	SENT serial configuration 1 = No serial protocol 3 = Enhanced serial protocol <b>Do not use 0, 1 or 2 to retain safety goal.</b>	3	2
SENT_INIT_GM	235	SENT initialization, 0 = transmitting 0 as initialization data 1 = transmitting 4095 as initialization data	0	1
<b>INPUT PIN CONFIGURATION</b>				
ABE_INPUT_MODE	183	Gateway configuration (Input pin): 0: gateway disabled 2 : analog Gateway, inverted 3: analog gateway 4: digital PWM input mode 5: binary mode	0	3
EXT_POL	181	0x0: In PWM, the input value is proportional to the high-state 0x1: In PWM, the input value is proportional to the low-state	0	1
GTW_SUP_SEL	184	Digital gateway supply selection: 0x0: 3.3V VS supply 0x1: 5.0V VS supply	0	1

Parameter	PSF value	Description	Default Values	
			Standard	#bits
DIAG_GTW_MIN	229	PWM diagnostic: minimum value for comparison. Complex timer 16-bit value is compared to NV_DIAG_GTW_MIN << 12 0xF corresponds to a PWM period of 41322us.	0	4
DIAG_GTW_MAX	230	PWM diagnostic: maximum value for comparison. Complex timer 16-bit value is compared to NV_DIAG_GTW_MAX << 12 0xF corresponds to a PWM period of 41322us.	15	4
GTW_BIAS_TR	239	bxxx100: Minimum value of the trimmed pull-up resistance (on pin INPUT) bxxx000: Nominal value of the trimmed pull-up resistance bxxx111: Maximum value of the trimmed pull-up resistance b001xxx: Connect a 1kOhm pull-up resistor between VDDA and INPUT b010xxx: Connect a 4kOhm pull-up resistor between VDDA and INPUT b100xxx: Connect a 10kOhm pull-up resistor between VDDA and INPUT	0	6

Table 42 - MLX90374 End-User Programmable Items Table

Performances described in this document are only achieved by adequate programming of the device. To ensure desired functionality, Melexis recommends following its programming guidelines and contacting its technical or application services. Melexis does not guarantee the safety of the element if the configuration of the device is done outside of the above defined values and recommendations.

## 11.1. End User Identification Items

Parameter	PSF value	Description	Default Values	
			Standard	#bits
USER_ID[0..5]	1..6	User Id. References	-	16
USER_ID0	1	Product Number for 90374ABB	16	8
		Product Number for 90374ABC	17	
USER_ID1	2	NVRAM factory default content revision		
		90374 ABB	8	8
		90374 ABC	9	
CHIP_VERSION	667	0 : Rotary Stray Field Robust (-1xx ordering code)		
		1 : Angular / Linear position legacy (-3xx ordering code)	-	7
		2 : Linear Stray Field Robust (-2xx ordering code)		
MLX_ID0	669	X-Y position on the wafer (8 bit each)	-	16
MLX_ID1	672	Wafer ID (5 bits)		
		Lot ID [10..0]	-	16
MLX_ID2	675	Lot ID [16..11]		
		Fab ID (4 bits)	-	16
		Test Database ID (6 bits)		

*Table 43 - Melexis and Customer ID fields description*

User identification numbers (48 bits, 6 words) are freely useable by customers for traceability purpose. Other IDs are read only.

## 12. Description of End-User Programmable Items

### 12.1. Sensor Front-End

The MLX90374 Triaxis® processor front end can be configured with the following parameters

Parameter	Value
SENSING MODE	[0..4]
GAINMIN	[0..63]
GAINMAX	[0..63]
GAINSATURATION	[0, 1]
B_OFS_1	[0..65535]
B_OFS_2	[0..65535]

Table 44 - Sensing Mode and Front-End Configuration

#### 12.1.1. SENSING MODE

The SENSING\_MODE parameter defines which sensing mode and fields are used to calculate the angle. The different possibilities are described in the tables below. This 2-bit value selects the first (B1) and second (B2) field components according to the Table 45 content.

SENSING_MODE	B1	B2	Angular Mode	Compatible with
0	X	Y	Angular Rotary stray-field Immune	ordering code -100
1	X	Y	X-Y Angular Rotary	ordering code -300
2	Y	Z	Y-Z Angular Rotary	ordering code -300
3	X	Z	X-Z Angular Rotary	ordering code -300
4	$\Delta X$	$\Delta Z$	Linear position, stray-field Immune	ordering code -200

Table 45 - Sensing Mode Description

#### 12.1.2. GAINMIN and GAINMAX Parameters

GAINMIN and GAINMAX define the thresholds on the gain code outside which the fault “GAIN out of Spec.” is reported. If GAINSATURATION is set, then the virtual gain code is saturated at GAINMIN and GAINMAX, and no Diagnostic fault is set since the saturations applies before the diagnostic is checked.

## 12.2. Sensor DSP Configuration

The MLX90374 Triaxis® Processor embeds a DSP that can be used to process the angle information through the signal chain displayed in the fig. 18. The angle input information  $\theta_{IN}$  can be shaped through two angular channels  $OUT_1$  and  $OUT_2$  as well as two switches signal  $KD_1$  and  $KD_2$ . These signals can then be routed to the MLX90374 physical outputs using available communication protocols (see section 12.3, Selection of Output modes).

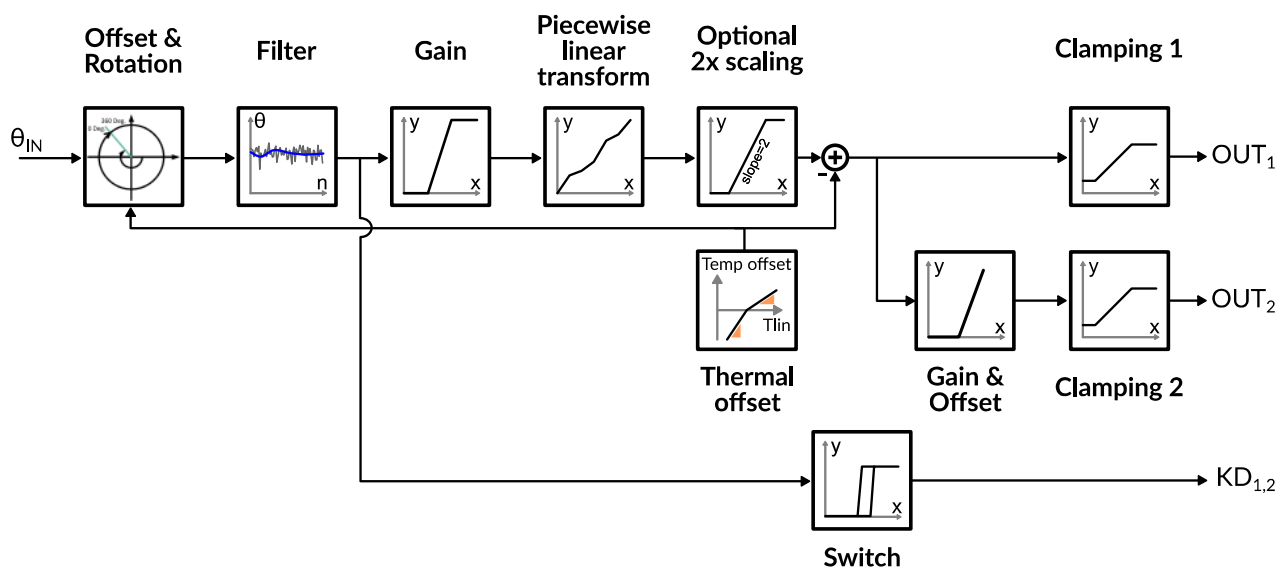

fig. 18 – MLX90374 Digital Processing Flow

Following table summarizes the parameters used for the DSP configuration

Parameter	LNR type	Value	Unit
CW	All	0 : counter clockwise 1 : clockwise	LSB
DP	All	0 ... 359.9999	deg
WORKING RANGE	17/32 pts	65.5 ... 360 32.75 ... 180	deg
WORK_RANGE_GAIN	All	x1 ... x15.94	-
LNRAX LNRBX LNRCX LNRDX	4 pts, X coordinates	0 ... 359.9999	deg
LNRAY LNRBY LNRCY LNRDY	4 pts, Y coordinates	0 ... 100 -50 ... + 150	%

Parameter	LNR type	Value	Unit
LNRS0 LNRAS LNRBS LNRCS LNRDS	4 pts, slopes	-17 ... 0 ... 17	%/deg
LNRX0 .. LNRX7	8 pts, X coordinates	0 ... 359.9999	deg
LNR Y0 ... LNR Y7 ... LNR Y16	8,17 pts, Y coordinates	0..100 -50 ... + 150	%
LNR_DELTAY01 ... LNR_DELTAY32	32 pts offsets	+/-3.125% +/-6.25% +/-12.5% +/-25%	%
CLAMPLOW / CLAMPLOW2	All	0 ... 100	%
CLAMPHIGH / CLAMPHIGH2	All	0 ... 100	%
CLAMP2_EN	All	0..1	-
OUT2SLOPERATIO	All	-800% .. +800%	%
OUT2OFFSET	All	-400% .. +400%	%

Table 46 - Output linearization and clamping parameters

### 12.2.1. Discontinuity Point (or Zero Degree Point)

The Discontinuity Point defines the 0° point on the circle. The discontinuity point places the origin at any location of the trigonometric circle. The DP is used as reference for all the angular measurements.

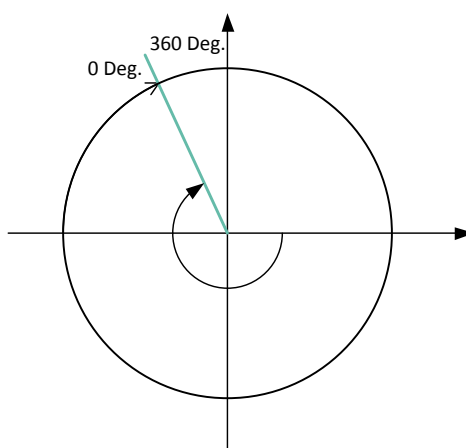

fig. 19 - Discontinuity Point Positioning

### 12.2.2. CW (Clockwise) Parameter

The CW parameter defines the magnet rotation direction.

- 0 or counter clockwise is defined by the 1-4-5-8 pin order direction for the SOIC-8 package and 1 2 3 4 pin order direction for DMP-4 package.
- 1 or clockwise is defined by the reverse direction: 8-5-4-1 pin order direction for the SOIC-8 and 4 3 2 1 pin order direction for DMP-4 package.

Refer to the drawing in the sensitive spot positioning section (17.4, 17.9).

### 12.2.3. Filter

The MLX90374 Triaxis® position processor includes 2 types of filters:

- A low pass FIR Filter controlled by the FILTER parameter
- An exponential moving average (EMA) Filter: programmable by the HYST parameter

Parameter	Value
FILTER	0 ... 2
HYST	0 ... 255

Table 47 - Filter configuration

#### 12.2.3.1. FIR Filter

The MLX90374 features 2 FIR filter modes controlled with FILTER = 1...2. FILTER = 0 corresponds to no filtering. The transfer function is described by:

$$y_n = \frac{1}{\sum_{i=0}^j a_i} \sum_{i=0}^j a_i x_{n-i}$$

This filter characteristic is given in the Table 48.

FILTER value	0	1	2
Type	Disabled	Finite Impulse Response	
Coefficients a <sub>i</sub>	1	11	1111
Title	No filter	ExtraLight	Light
DSP cycles (nb of taps)	1	2	4
Efficiency RMS (dB)	0	3.0	6.0

Table 48 - FIR Filter Characteristics



### 12.2.3.2. Exponential Moving Average (IIR) Filter

The HYST parameter is a hysteresis threshold to activate / de-activate the exponential moving average filter. The output value of the IC is updated with the applied filter when the digital step is smaller than the programmed HYST parameter value. The output value is updated without applying the filter when the increment is bigger than the hysteresis. The filter reduces therefore the noise but still allows a fast step response for bigger angle changes. The hysteresis must be programmed to a value close to the internal magnetic angle noise level ( $1LSB = 8 \cdot 360/2^{16}$ ).

$$y_n = a * x_n + (1-a) * y_{n-1} \quad \begin{array}{l} x_n = \text{Angle} \\ y_n = \text{Output} \end{array}$$

The filters characteristic is given in the following table (Table 49):

DENOISING_FILTER_ALPHA_SEL	0	1	2	3
Coefficients a	0.75	0.5	0.25	0.125
Efficiency RMS (dB)		2.4	4.2	

Table 49 - IIR Filter characteristics

### 12.2.4. WORKING\_RANGE Parameter for Angle Range Selection

The parameter WORKING\_RANGE determines the input range on which the 16 or 32 segments are uniformly spread. This parameter is provided for compatibility with former versions of MLX Triaxis sensors. For full featured working range selection, see section 12.2.5. For WORKING\_RANGE parameter (W), following table applies. Outside of the selected range, the output will remain at clamping levels.

W	Range	$\Delta x$ 17pts	$\Delta x$ 32pts
0	180.0°	11.3°	5.6°
1	160.0°	10.0°	5.0°
2	144.0°	9.0°	4.5°
3	131°	8.2°	4.1°
4	120.0°	7.5°	3.8°
5	221.5°	6.9°	3.5°
6	103°	6.4°	3.2°
7	96°	6.0°	3.0°

W	Range	$\Delta x$ 17pts	$\Delta x$ 32pts
8	90.0°	5.6°	2.8°
9	72.0°	4.5°	2.3°
10	60.0°	3.8°	1.9°
11	51.45°	3.2°	1.6°
12	45.0°	2.8°	1.4°
13	40.0°	2.5°	1.3°
14	36.0°	2.3°	1.1°
15	32.75°	2.0°	1.0°

Table 50 - Working range for 180° periodicity (order code -100)

W	Range	$\Delta x$ 17pts	$\Delta x$ 32pts	W	Range	$\Delta x$ 17pts	$\Delta x$ 32pts
0	360.0°	22.5°	11.3°	8	180.0°	11.3°	5.6°
1	320.0°	20.0°	10.0°	9	144.0°	9.0°	4.5°
2	288.0°	18.0°	9.0°	10	120.0°	7.5°	3.8°
3	261.8°	16.4°	8.2°	11	102.9°	6.4°	3.2°
4	240.0°	15.0°	7.5°	12	90.0°	5.6°	2.8°
5	221.5°	13.8°	6.9°	13	80.0°	5.0°	2.5°
6	205.7°	12.9°	6.4°	14	72.0°	4.5°	2.3°
7	192.0°	12.0°	6.0°	15	65.5°	4.1°	2.0°

Table 51 - Working range for 360° periodicity (order code -200, -300)

### 12.2.5. WORK\_RANGE\_GAIN Parameter for Angle Range Selection

Alternatively, the range for the angle can be selected using the WORK\_RANGE\_GAIN parameter, which applies a fixed gain to the transfer characteristic. When using WORK\_RANGE\_GAIN parameter, the anchor point is set in the middle of the full angular range, MaxRange/2, and the valid range is set symmetrically around this value based on the parameter value.

WORK\_RANGE\_GAIN is coded on 8 bits where the 4 MSB defines the integer part and the 4 LSB the fractional part. Therefore, the following equation applies to define the angle range w:

$$w = \frac{16 * \text{MaxRange}}{\text{WORK\_RANGE\_GAIN}}$$

MaxRange depends on the application. It is 360° for ordering codes -200 and -300 (linear stray-field immune and legacy) and 180° for ordering code -100 (rotary stray-field immune). Both minimal and maximal angles are then defined by :

$$\theta_{min} = \frac{\text{MaxRange} - w}{2} ; \theta_{max} = \frac{\text{MaxRange} + w}{2}$$

where  $\theta_{min}$  corresponds to the angle giving an output of 0% and  $\theta_{max}$  the angle giving an output of 100%. Following tables give some values as example. Outside of the working range, the output will remain at clamping levels.

WORK_RANGE_GAIN	Zoom Factor	Range (w)	$\theta_{min}$	$\theta_{max}$	$\Delta x$ 17pts	$\Delta x$ 32pts
0x10	1	180°	0°	180°	11.25°	5.63°
0x20	2	90°	45°	135°	5.63°	2.81°
0x40	4	45°	67.5°	112.5°	2.81°	1.41°
0xFF	15.94	11.3°	78.7°	101.3°	0.71°	0.35°

Table 52 - Working range defined by WORK\_RANGE\_GAIN parameter (ordering codes -100)

WORK_RANGE_GAIN	Zoom Factor	Range (w)	$\theta_{min}$	$\theta_{max}$	$\Delta x$ 17pts	$\Delta x$ 32pts
0x10	1	360°	0°	360°	22.5°	11.3°
0x20	2	180°	90°	270°	11.3°	5.6°
0x40	4	90°	135°	225°	5.6°	2.8°
0xFF	15.94	22.6°	168.7°	191.3°	1.41°	0.71°

Table 53 - Working range defined by WORK\_RANGE\_GAIN parameter (ordering codes -200, -300)

## 12.2.6. Piecewise Linear Transform

There are 4 different possibilities to define the transfer function (LNR). Configuration is specified in the Table 54.

- With 4 arbitrary points (defined by X and Y coordinates) and 5 slopes
- With 8 arbitrary points (defined by X and Y coordinates)
- With 17 equidistant points for which only the Y coordinates are defined
- With 32 equidistant points for which only offset of Y compared to the average value is defined

Output Transfer Characteristic	4POINTS	DSP_LNR_RESX2
4 Arbitrary Points	1	0
8 Arbitrary Points	1	1
17 Equidistant Points	0	0
32 Equidistant Points	0	1

Table 54 - Output Transfer Characteristic Selection Table

### 12.2.6.1. 4-Pts LNR Parameters

The LNR parameters, together with the clamping values, fully define the relation (the transfer function) between the digital angle and the output signal.

The shape of the MLX90374 four points transfer function from the digital angle value to the digital output is described in the following figure (fig. 20). Seven segments can be programmed but the clamping levels are necessarily flat. Two, three, or even six calibration points are then available, reducing the overall non-linearity of the IC by almost an order of magnitude each time. Three or six calibration point will be preferred by customers looking for excellent non-linearity figures. Two-point calibrations will be preferred by customers looking for a cheaper calibration set-up and shorter calibration time.

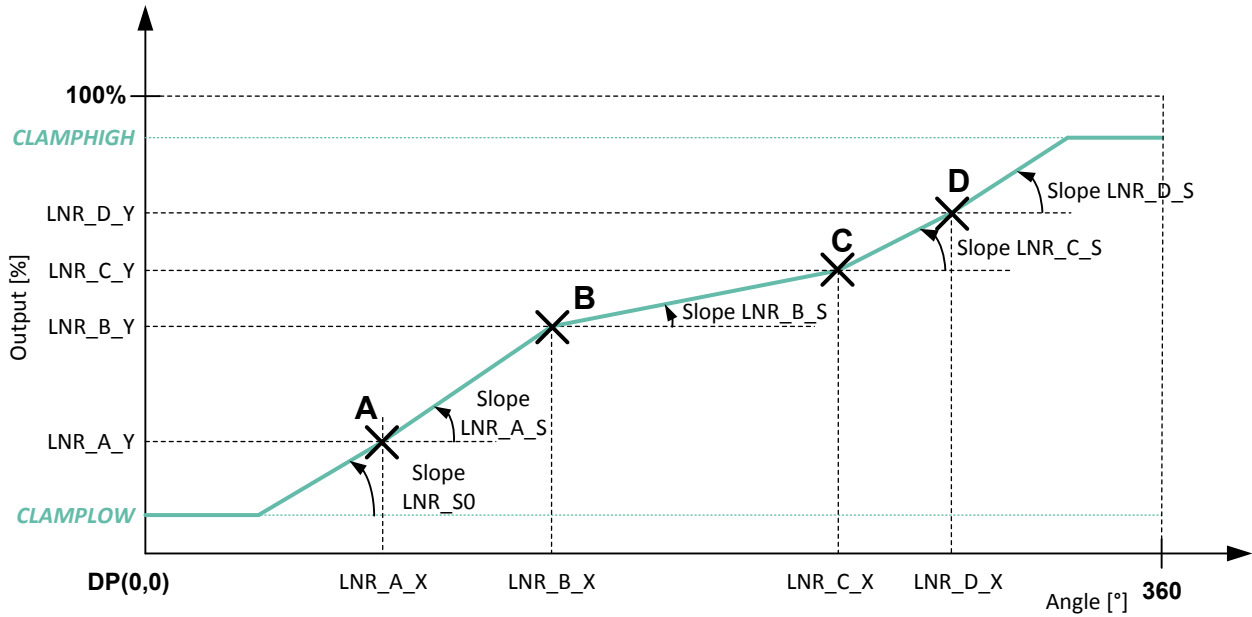

fig. 20 - 4pts Linearisation Parameters Description

### 12.2.6.2. 8-Pts LNR Parameters

The 8-Pts LNR parameters, together with the clamping values, fully define the relation (the transfer function) between the digital angle and the output signal.

The shape of the MLX90374 eight points transfer function from the digital angle value to the output voltage is described in the following figure (fig. 21). Eight calibration points [LNR\_X0...7, LNR\_Y0...7] together with 2 fixed points at the extremity of the range ([0°, 0%] ; [360°, 100%]) divides the transfer curve into 9 segments. Each segment is defined by 2 points and the values in between is calculated by linear interpolation.

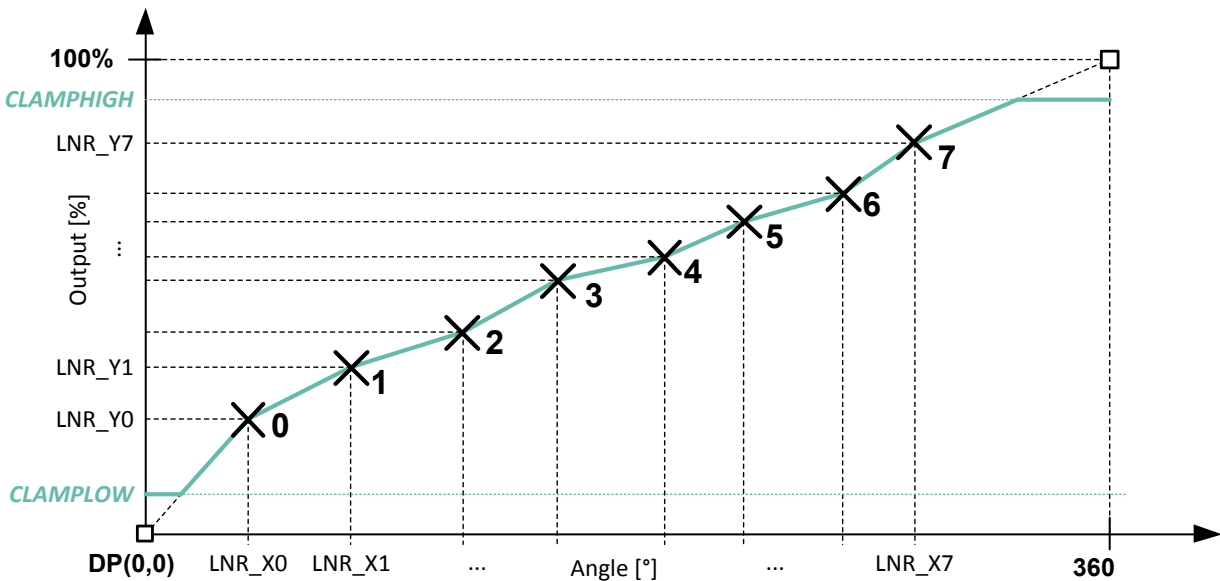

fig. 21 - 8pts Linearisation Parameters Description

### 12.2.6.3. 17-Pts LNR Parameters

The LNR parameters, together with the clamping values, fully define the relation (the transfer function) between the digital angle and the output signal.

The shape of the MLX90374 seventeen points transfer function from the digital angle value to the output voltage is described in the following figure (fig. 22). In the 17-Pts mode, the output transfer characteristic is Piece-Wise-Linear (PWL).

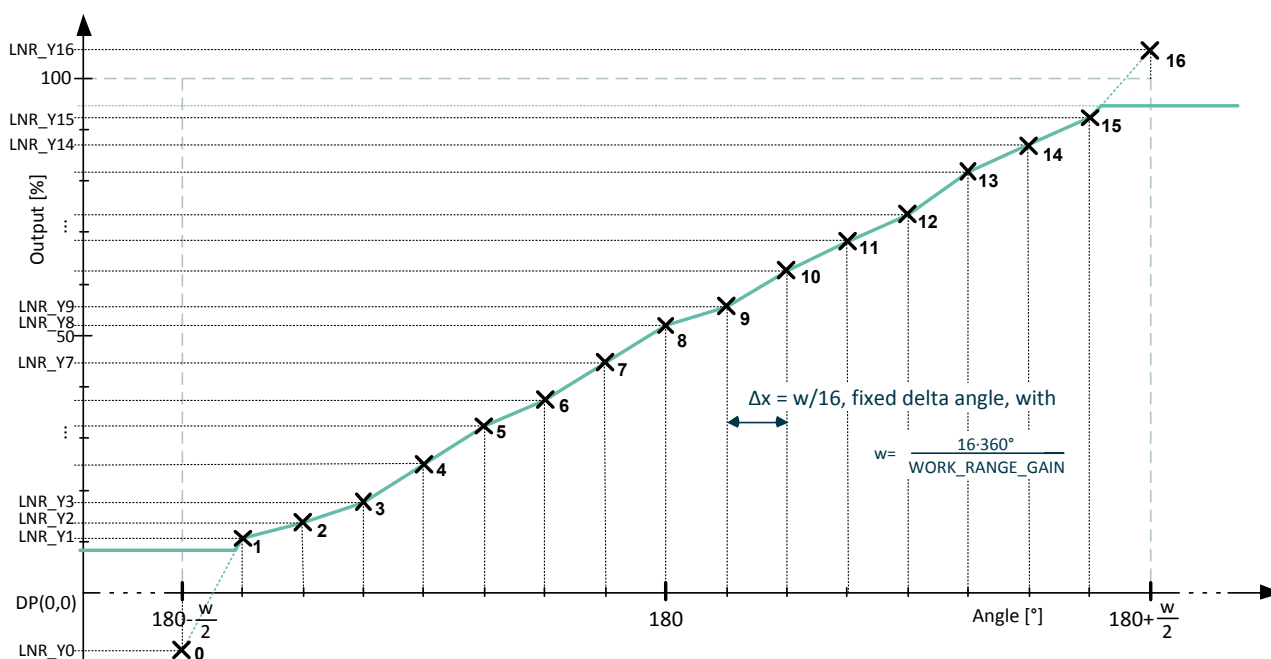

fig. 22 - 17pts Linearisation Parameters Description

All the Y-coordinates can be programmed from -50% up to +150% to allow clamping in the middle of one segment (like on the figure), but the output value is limited to CLAMPLOW and CLAMPHIGH values. Between two consecutive points, the output characteristic is interpolated.

### 12.2.6.4. 32-Pts LNR parameters

The LNR parameters, together with the clamping values, fully define the relation (the transfer function) between the digital angle and the output signal.

The shape of the MLX90374 thirty-two points transfer function from the digital angle value to the output voltage is described in the following figure (fig. 23). In the 32-Pts mode, the output transfer characteristic is Piece-Wise-Linear (PWL).

The points are spread evenly across the working range (see. 12.2.4 and 12.2.5 for working range selection). The Y-coordinates can be offset from the ideal characteristic within an adjustable range defined by LNR\_DELTA\_Y\_EXPAND\_LOG2. The available values are summarized in Table 55. All LNR\_delta\_Y## parameters are encoded in a fractional signed 8-bit value.

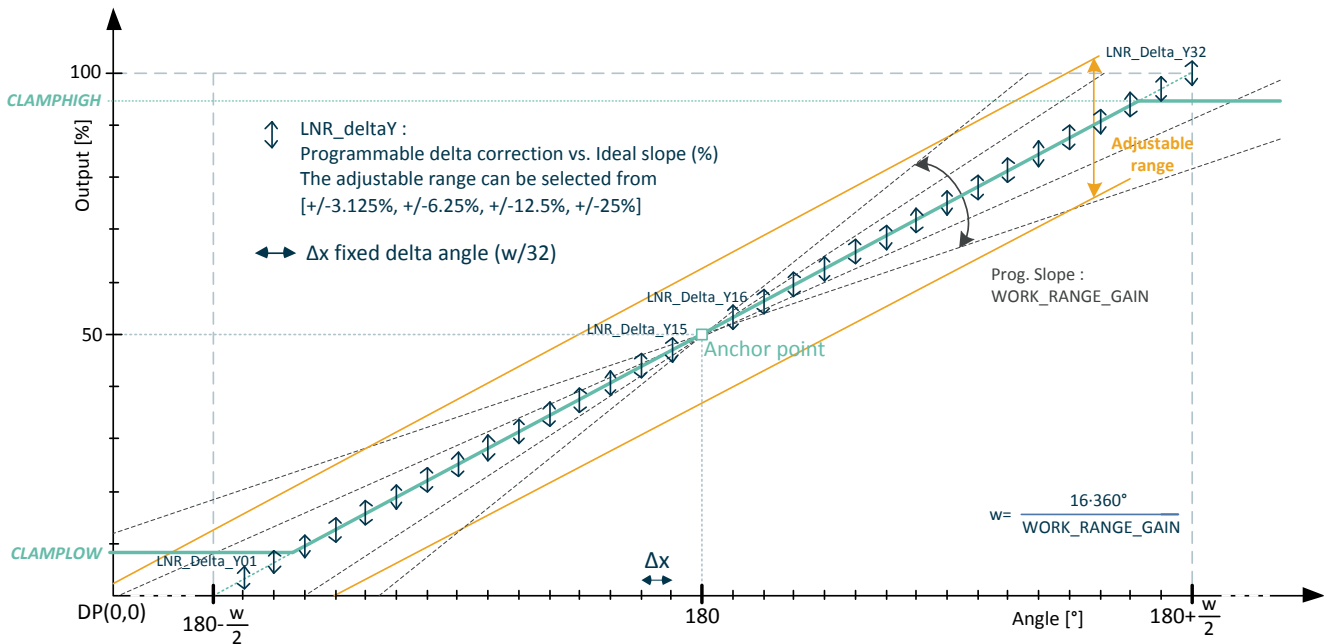

fig. 23 - 32pts Linearisation Parameters Description

LNR_DELTA_Y_EXP AND_LOG2	Adjustable Range	Correction resolution
0	±3.125%	0.024%
1	±6.25%	0.049%
2	±12.5%	0.098%
3	±25%	0.20%

Table 55 - LRN\_DELTA\_Y\_EXPAND\_LOG2 values and correction resolution

### 12.2.7. Scaling Parameter

When enabled, this parameter doubles the scale of Y coordinates linearisation parameters from [0 .. 100]% to [-50 .. 150]% according to the following table (Table 56). This is valid for all linearisation schemes except the 32 points.

USEROPTION_SCALING	LNR_Y min value	LNR_Y max value
0	0%	100%
1	-50%	150%

Table 56 - USEROPTION\_SCALING parameter

### 12.2.8. Thermal offset correction- OUTSLOPE

Two parameters, OUTSLOPE\_HOT and OUTSLOPE\_COLD, are used to add a temperature dependent offset. This feature is enabled by the parameter OUTSLOPE\_SEL that apply this modification either directly to the angle or after the linearisation and scaling functions. This thermal offset is only available with the revision ABC of the MLX90374. The MLX90374 Triaxis® position processor uses its internal linearized temperature to compute the offset shift as depicted in the figure below (fig. 24)

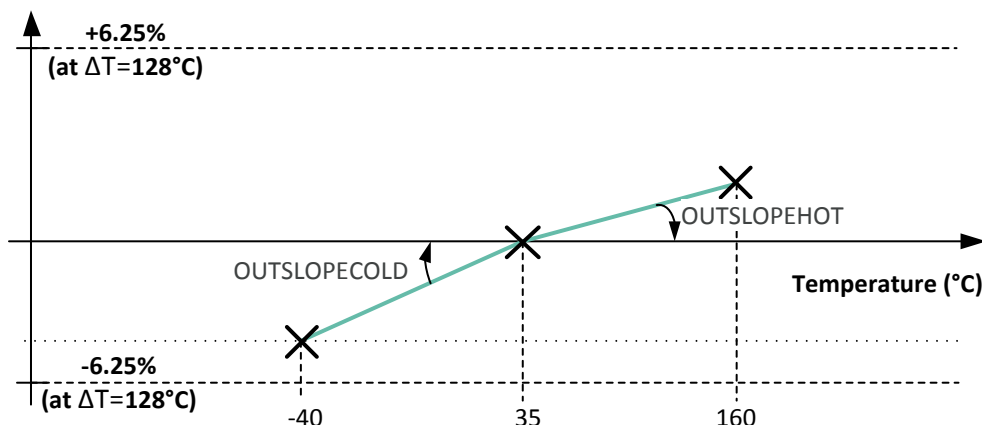

fig. 24 - Temperature compensated offset

The thermal offset can be added or subtracted before the clamping, either to the angle or output. The span of this offset is  $\pm 6.25\%$  of the full output scale for a temperature difference of  $128^\circ\text{C}$ . The added thermal offset varies with temperature following the equations below. The two thermal coefficients are encoded in signed two's complement 8bit format (-128..127) and defined separately below  $35^\circ\text{C}$  (OUTSLOPE\_COLD) and above  $35^\circ\text{C}$  (OUTSLOPE\_HOT).

OUTSLOPE_SEL	Description
0	No thermal offset correction
1	Thermal offset enabled, applied after angle calculation, i.e. after discontinuity point ( $\theta_{r2p}$ )
2	Thermal offset enabled, applied after output calculation and before clamping ( $\theta_{out}$ )

Table 57 - Temperature compensated offset selection parameter

If IC internal temperature is higher than  $35^\circ\text{C}$  then:

$$\theta_{Tcomp} = \theta_{in}(1 - \Delta T \cdot \text{OUTSLOPE\_HOT})$$

If IC internal temperature is lower than  $35^\circ\text{C}$  then:

$$\theta_{Tcomp} = \theta_{in}(1 - \Delta T \cdot \text{OUTSLOPE\_COLD})$$

where  $\theta_{in}$  is either  $\theta_{r2p}$  or  $\theta_{out}$  depending on OUSLOPE\_SEL value.

### 12.2.9. Second Output Gain and Offset Parameters

The MLX90374 ABC revision offers the possibility to program a second output transfer characteristic.  $OUT_2$  can be linearly transposed from  $OUT_1$  with the following relationship and parameters:

$$OUT_2 = OUT2OFFSET + OUT2SLOPERATIO * OUT_1$$

Both parameters are encoded on 16bits in two's complement with the range defined in Table 46 - Output linearization and clamping parameters.

### 12.2.10. CLAMPING Parameters

The clamping levels are two independent values to limit the output voltage range. The CLAMPLOW parameter adjusts the minimum output level. The CLAMPHIGH parameter sets the maximum output. Both parameters have 16 bits of adjustment and are available for all four LNR modes. As output data resolution is limited to 12bits, both in SENT and in PWM, the 4 LSB of this parameter will have no significant effect on the output. The value is encoded in fractional code, from 0% to 100%

On the MLX90374 ABC revision, the second output  $OUT_2$  can use different clamping values when CLAMP2\_EN is set. These parameters are names CLAMPLOW2 and CLAMPHIGH2 and use the same encoding than CLAMPHIGH and CLAMPLOW.

## 12.3. Selection of Output modes

This section describes the option to connect the DSP output signals to the physical IOs of the MLX90374 through the two possible output protocols, PWM and SENT. The following picture displays the possibilities offered by the MLX90374 Triaxis® processor. Some features are only available with the ABC revision of the device. Refer to the corresponding sections for more details.

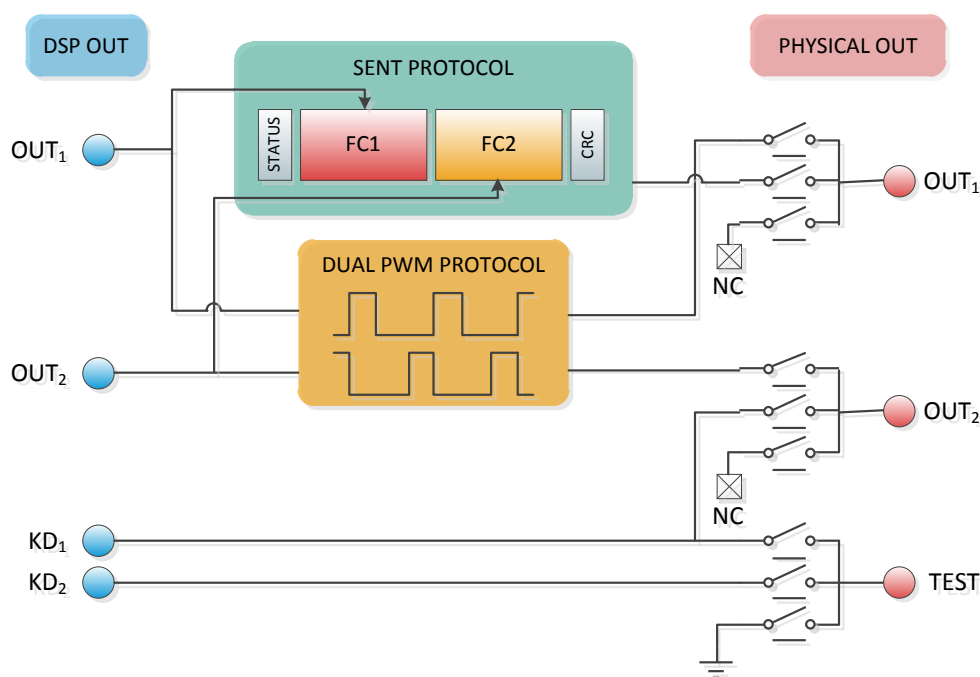

fig. 25 – Output Protocols selection and connection matrix



### 12.3.1. Digital Output Protocol (PROTOCOL)

Selection of the output protocol and the corresponding timing mode.

PROTOCOL	Type	Descriptions
0	SENT	Continuous asynchronous angle acquisition, SENT without pause pulse
1	PWM	Continuous asynchronous angle acquisition, PWM protocol
2	SENT	Continuous synchronous angle acquisition, SENT with pause

Table 58 - Protocol Selection

### 12.3.2. PWM Output Polarity and Frequency

If PWM output mode is selected, the output signal is a digital signal with Pulse Width Modulation (PWM). The PWM polarity is selected by the PWM\_POL parameter:

- PWM\_POL = 0 for a low level at 100%
- PWM\_POL = 1 for a high level at 100%

The PWM frequency is selected in the range [100, 2000] Hz by the T\_FRAME parameter (12bits), defining the period time in the range [0.5; 10] ms. Minimum allowed value for T\_FRAME is therefore 125 (0x7d).

$$T_{PWM} = \frac{4}{10^6} \times T_{FRAME}$$

- PWM period is subject to the same tolerances as the main clock (see  $\Delta T_{ck}$ ).

### 12.3.3. PWM Redundant Output

A second PWM output (OUT<sub>2</sub>) can be enabled with the parameter PWM2\_EN = 1 with the primary target to provide a redundant version of the PWM primary output (OUT<sub>1</sub>). Without further modification and once enabled, the OUT<sub>2</sub> duty cycle is by default equal to:

$$DC_{OUT2} (\%) = 100\% - DC_{OUT1} (\%)$$

### 12.3.4. Dual PWM fault Reporting Mode

The ABC revision of the MLX90374 offers the possibility to select the fault reporting mode in dual PWM mode. In presence of a fault, the circuit will issue a signal with a duty cycle corresponding to the detected analog fault (see Table 42, PWM\_DC\_FAULT, PWM\_DC\_FIELDTOOLow, PWM\_DC\_WEAKMAG). With the help of PWM\_OUT\_MODE, the user can select between redundant signals in the fault band or to keep either the angle information on OUT<sub>1</sub> or OUT<sub>2</sub>.

### 12.3.5. OUT mode (ABE\_OUT\_MODE)

ABE\_OUT\_MODE defines the Output Stage physical mode used in application for both OUT<sub>1</sub> and OUT<sub>2</sub>.

ABE_OUT_MODE	Type	Description	Comments
0	SENT	Push-Pull	
1	SENT	Open Drain	requires a pull-up resistor
2	PWM	Push-Pull	
3	PWM	Open Drain	requires a pull-up resistor

Table 59 - Output Mode Selection

### 12.3.6. SENT Serial Channel Configuration- Status and Communication Nibble

SERIAL_CONFIG	Type	Descriptions
0	-	Status and Communication nibble is not present. This configuration is not compliant with SENT. <b>Do Not Use!</b>
1	nsp	Status nibble will report an error. Data sent along the serial channel is taken from RAM.
2	ssp	This short serial protocol is not compliant with SENT. <b>Do Not Use!</b>
3	esp	Status nibble reports errors and serial channel reports sequence defined in 10.2.7

Table 60 - SENT Serial channel Configuration

### 12.3.7. Switch Function (Kickdown)

The MLX90374 Triaxis position processor offers up to two switch functions with programmable polarity, threshold and hysteresis. The configuration of the kickdown outputs are defined in following table.

KICKDOWN_EN	Switch configuration (ABB)	Switch configuration (ABC)
0	Kickdown disabled	Kickdown disabled
1	Enabled on OUT <sub>2</sub>	KD <sub>1</sub> enabled on TEST output
2	Not Available on ABB revision	KD <sub>1</sub> enabled on OUT <sub>2</sub>
3	Not Available on ABB revision	KD <sub>1</sub> enabled on OUT <sub>2</sub> and KD <sub>2</sub> enabled on TEST output

Table 61 – Switch Function Selection (Kickdown)

The switch behaviour is defined by the three parameters listed in Table 62. The switch function is compared to the angle before any gain function applies (see fig. 18 – MLX90374 Digital Signal Processing Flow). Therefore, the full scale (100%) corresponds to the full magnetic range of the sensor (see 12.2.4 and 12.2.5).

PARAMETER	Description	Comment
KICKDOWN_POL	Select switch(es) polarity	0: Normal polarity (KD=1 if input>threshold) 1: Inverted polarity (KD=1 if input<threshold)
KICKDOWN_THRES_UP	Threshold for switch activation	0-100% on 12bits
KICKDOWN_THRES_HYST	Hysteresis for switch return point	<b>ABB revision :</b> 0 - 4.7% on 2bits with 1.56% steps <b>ABC revision :</b> 0 - 0.3% on 2bits with 0.1% steps
KICKDOWN_THRES_UP2	Threshold for second switch activation	Similar to KICKDOWN_THRES_UP
KICKDOWN_THRES_HYST2	Hysteresis for second switch return point	Similar to KICKDOWN_THRES_HYST

Table 62 – Switch Function Configuration (Kickdown)

## 12.4. Programmable Diagnostics Settings

### 12.4.1. Diagnostics Global Enable

DIAG\_EN should be kept to its default value (1) to retain all functional safety capabilities of the MLX90374. This feature shall not be disabled.

### 12.4.2. Diagnostic Debouncer

A debouncing algorithm is available for analog diagnostic reporting (see chapter 13, Functional Safety). This debouncer is disabled by default. Enabling it increases the reporting time of the device. Therefore, Melexis recommends keeping the debouncing of analog faults off by not modifying debouncer default values (see Table 42 for factory default values).

NVRAM Parameter	Description
DIAGDEBOUNCE_STEPDOWN	Decrement values for debouncer counter
DIAGDEBOUNCE_STEPUP	Increment value for debouncer counter
DIAG_DEBOUNCE_THRESH	Threshold for debouncer counter to enter diagnostic mode

Table 63 - Diagnostic debouncing parameters

Once an analog monitor detects an error, it takes control of the debouncing counter. This counter will be incremented by STEPUP value each time this specific monitor is evaluated, and the error is still present. When the debouncing counter reaches the value defined by DEBOUNCE THRESHOLD, an error is reported on the error channel, and the debouncing counter stays clamped to this DEBOUNCE THRESHOLD value (see 10.2.8 for SENT error message codes, 12.4.4 for PWM error reporting). Once the error disappears, each time its monitor is evaluated, the debouncing counter is decremented by STEPDOWN value. When the debouncing counter reaches zero, the error disappears from the reporting channel and the debouncing counter is released. To implement proper reporting times, one should refer to the DCT defined in the Table 9. The reporting and recovery time are defined in the table below (valid for THRESH≠0).

Parameter	Min	Max
Reporting Time	$DCT \cdot \left( \left\lceil \frac{THRESH}{STEPUP} \right\rceil - 1 \right)$	$DCT \cdot \left( \left\lceil \frac{THRESH}{STEPUP} \right\rceil \right)$
Recovery Time	$DCT \cdot \left( \left\lceil \frac{THRESH}{STEPDOWN} \right\rceil \right)$	$DCT \cdot \left( \left\lceil \frac{THRESH}{STEPDOWN} \right\rceil + 1 \right)$
	$\left\lceil \frac{x}{y} \right\rceil$	is the ceiling function of x divided by y

Table 64 - Diagnostic Reporting and Recovery times

### 12.4.3. Over/Under Temperature Diagnostic

DIAG\_TEMP\_THR\_HIGH defines the threshold for over temperature detection and is compared to the linearized value of the temperature sensor  $T_{LIN}$

DIAG\_TEMP\_THR\_LOW defines the threshold for under temperature detection and is compared to the linearized value of the temperature sensor  $T_{LIN}$

$T_{LIN}$  is encoded using the SENT standard for temperature sensor. One can get the physical temperature of the die using following formula:

$$T_{PHY} [^{\circ}C] = \frac{T_{LIN}}{8} - 73.15$$

DIAG\_TEMP\_THR\_LOW/HIGH are encoded on 8-bit unsigned values with the following relationship towards  $T_{Lin}$

$$DIAG\_TEMP\_THR\_(LOW/HIGH) = \frac{T_{LIN}}{16}$$

Following table summarizes the characteristics of the linearized temperature sensor and the encoding of the temperature monitor thresholds.

Parameter	Symbol	Min	Typ	Max	Unit	Condition
T <sub>LIN</sub> resolution	Re <sub>STLIN</sub>	-	0.125	-	°C/LSB	
T <sub>LIN</sub> refresh rate	F <sub>S,TLIN</sub>	-	200	-	Hz	
T <sub>LIN</sub> linearity error	T <sub>LinErr</sub>	-8	-	8	°C	from -40 to 160°C
High temperature threshold	DIAG_TEMP_THR_HIGH	-	8	-	LSB	Recommended value, corresponds to -57°C
Low temperature threshold	DIAG_TEMP_THR_LOW	-	136	-	LSB	Recommended value, corresponds to 199°C
High/low temperature threshold resolution	Re <sub>SThr</sub>		2		°C/LSB	

Table 65 - Linearized Temperature Sensor characteristics

#### 12.4.4. PWM Diagnostic

In presence of an analog fault and when PWM\_REPORT\_MODE\_ANA = 1, the PWM signal output a duty cycle in the fault band defined by the following configuration items.

PWM\_DC\_FAULT

PWM\_DC\_FIELDTOLOW

PWM\_DC\_WEAKMAG

PWM\_DC\_FAULT

This parameter defines the duty-cycle that is present on PWM output in presence of an analog fault. This duty cycle shall be used for generic diagnostic reporting.

WEAKMAGNET

This parameter defines the threshold on the field strength which determines the weak magnet condition; when PWM\_DC\_WEAKMAG = 0, there is no reporting of weak magnet condition. The encoding is similar than the encoding of FieldTooLow (see tables of chapter 7, Magnetic Field Specifications)

PWM\_DC\_WEAKMAG

This parameter defines the output duty-cycle in case of Weak Magnet, from 0% till 100% by steps of (100/256)%

PWM\_DC\_FIELDTOLOW

This parameter defines the duty-cycle that is output in case of Field Too Low; the Field Too Low Diagnostic prevails over the Weak Magnet Diagnostic. Encoding of the duty cycle is from 0% till 100 % by steps of (100/256)%

## 13. Functional Safety

### 13.1. Safety Manual

The safety manual, available upon request, contains the necessary information to integrate the MLX90374 component in a safety related item, as Safety Element Out-of-Context (SEoC).

In particular it includes:

- The description of the Product Development lifecycle tailored for the Safety Element.
- An extract of the Technical Safety concept.
- The description of Assumptions-of-Use (AoU) of the element with respect to its intended use, including:
  - assumption on the device safe state;
  - assumptions on fault tolerant time interval and multiple-point faults detection interval;
  - assumptions on the context, including its external interfaces;
- The description of safety analysis results at the device level useful for the system integrator; HW architectural metrics and description of dependent failures initiators.
- The description and the result of the functional safety assessment process; list of confirmation measures and description of the independency level.

### 13.2. Safety Mechanisms

The MLX90374 provides numerous self-diagnostic features (safety mechanisms). Those features increase the robustness of the IC functionality by either preventing the IC to provide an erroneous output signal or reporting the failure according to the SENT protocol definition.

Legend
● High coverage
○ Medium coverage
ANA : Analog hardware failure reporting, described in the safety manual
High-Z : Special reporting, output is set in high impedance mode (no HW fail-safe mode/timeout, no SW safe startup)
DIG : Digital hardware failure reporting, described in the safety manual
* : Diagnostic Cycle Time (see 6.1 for values)
At Startup : HW fault present at time zero is detected before a first frame is transmitted.
DIAG_EN : This safety mechanism can be disabled by setting DIAG_EN = 0 (see 11 End-User Programmable Items). This option should not be used in application mode!

*Table 66 - Self Diagnostic Legend*

Category and safety mechanism name	Front-end	ADC	DSP	Back-end	Sup port. Func.	Module & Package	DCT*	Reporting mode	At startup	DIAG EN
<b>Signal-conditioning (AFE, External Sensor) Diagnostic</b>	●	●				●		ANA		
Magnetic Signal Conditioning Voltage Test Pattern	●	○	○				DCT_Ana	ANA		●
Magnetic Signal Conditioning Rough Offset Clipping check	●		○				DCT_Ana	ANA	NO	●
Magnetic Signal Conditioning Gain Monitor	●		○			●	DCT_Ana	ANA	YES	●
Magnetic Signal Conditioning Gain Clamping	●		○			●	DCT_Ana	ANA	YES	
Mag. Sig. Cond. Failure control by the chopping technique	●						n/a	n/a	YES	
External Sensor Sig. Cond. Voltage Valid Range Check	●					●	DCT_Ana	ANA	YES	○ <sup>(40)</sup>
External Sensor Sig. Cond. Frequency Valid Range Check	●					●	DCT_Ana	ANA	YES	●
A/D Converter Test Pattern		●					DCT_Ana	ANA		●
ADC Conversion errors & Overflow Errors		●					DCT_Ana	ANA	YES	●
Flux Monitor (Specific to Rotary mode)	●	○				●	DCT_Ana	ANA	YES	●
<b>Digital-circuit Diagnostic</b>			●					DIG		
RAM Parity, 1 bit per 16 bits word, ISO D.2.5.2			●				<10µs	DIG	YES	●
ROM Parity, 1 bit per 16 bits word, ISO D.2.5.2			●				<10µs	DIG	YES	●
NVRAM 16 bits signature (run-time) ISO D.2.4.3			●				DCT_dig	DIG		
NVRAM Single Error Correction ECC			●				n/a	n/a	YES	
NVRAM Double Error Detection ECC			●				DCT_Dig	DIG	YES	

<sup>40</sup> This safety mechanism is disabled by default.

Category and safety mechanism name	Front-end	ADC	DSP	Back-end	Sup port. Func.	Module & Package	DCT*	Reporting mode	At startup	DIAG EN
Logical Monitoring of program sequence ISO D.2.9.3 via Watchdog "IWD" (cpu clock) ISO D2.9.2			●		○		Tiwd	DIG		●
Watchdog "AWD" (separate clock) ISO D2.9.1			●		○		Tawd	DIG		
CPU Errors "Invalid Address", "Wrong opcode"			●		○		<10μs	DIG	YES	
ADC Interface Checksum		●					DCT_Dig	DIG	NO	●
DSP Test Pattern (atan2)			●		○		DCT_Dig	DIG		●
Critical ports monitoring			●				DCT_Dig	DIG	NO	●
<b>SENT H/W Interface Diagnostic</b>				●				DIG		
SENT parity check over Configuration registers				●			<10μs	DIG	NO	●
SENT block: Protection against re-configuration at run-time				●			<10μs	DIG	NO	●
SENT Frame Counter & Redundant Nibble				●			n/a	n/a	n/a	
<b>System-level diagnostic</b>					●	●		ANA		
Supply Voltage Monitors (all supply domains) except VS_OV & POR					●	●	DCT_Ana	ANA	NO	●
External Supply Overvoltage Monitor VS_OV					●	●	2.1ms <sup>(41)</sup>	High-Z	YES	
Digital Supply under-voltage monitor (Power-on reset)					●	●	<10μs <sup>(42)</sup>	High-Z	YES	
Supply Bias Current Monitor					●		DCT_Ana	ANA		●

<sup>41</sup> This DCT is valid for detection. The recovery time of this diagnostic is defined by DCT\_Ana. The debouncer is not active for this diagnostic (12.4.2)

<sup>42</sup> After a detection of this diagnostic, the circuit performs a standard reset sequence. The recovery time of this diagnostic is consequently defined by the startup time (6.3.1).



Category and safety mechanism name	Front-end	ADC	DSP	Back-end	Sup port. Func.	Module & Package	DCT*	Reporting mode	At startup	DIAG EN
Overheating monitor	○	○	○	○	○	●	DCT_Ana	ANA	YES	●
<b>Warning/Reporting Mechanisms</b>							n/a	n/a		
HW Error Controller			●	●	●		n/a	DIG	YES	
HW Fail-safe mode with timeout			●	●	●		n/a	DIG	YES	
Analog-type Error management	●	●			●		n/a	ANA		
Safe start-up mode			●		●		n/a	DIG	n/a	
<b>Mechanisms executed at start-up only</b>										
RAM March-C HW Test at start-up			●		●		n/a	DIG	YES	

Table 67 - MLX90374 List of Self Diagnostics with Characteristics

## 14. Recommended Application Diagrams

### 14.1. Wiring with the MLX90374 in SOIC-8 Package

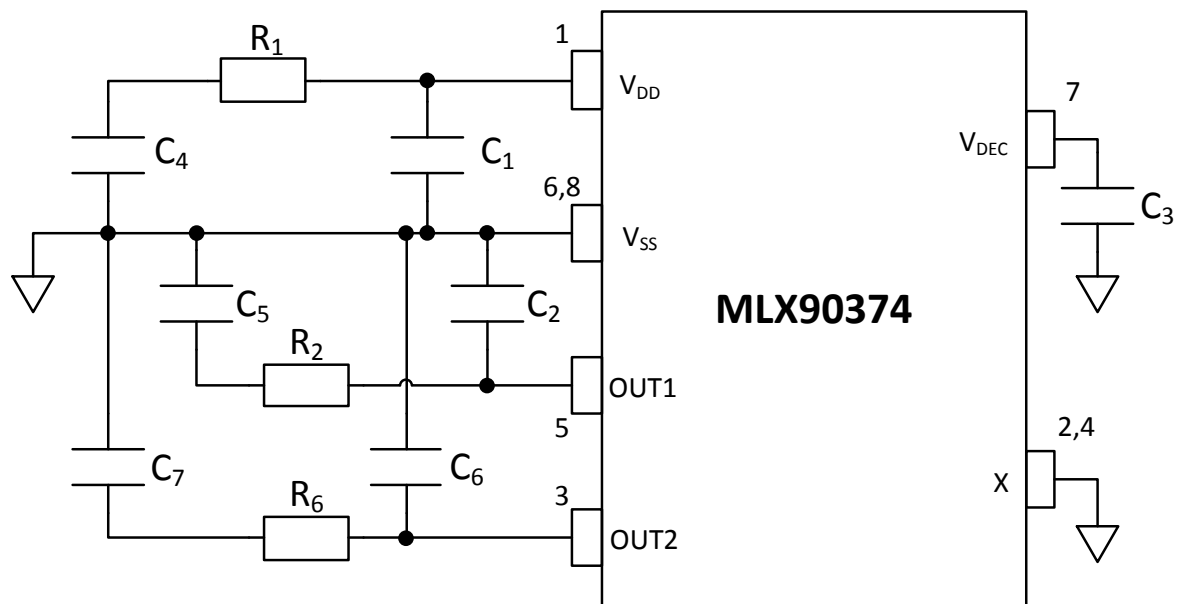

fig. 26 - Recommended wiring for the MLX90374 in SOIC-8 package

Component	min	Typ	Max	Remark
C <sub>1</sub>	100 nF	220 nF	-	Close to the IC pin
C <sub>2</sub> , C <sub>6</sub> (C <sub>L</sub> )	-	4.7nF 2.2nF	10nF 4.7nF	normal SENT/PWM fast SENT
C <sub>3</sub>	47 nF	100 nF	-	Close to the IC pin
C <sub>4</sub>	0	1nF	-	Close to the connector
C <sub>5</sub> , C <sub>7</sub>	0	1nF	15nF	Close to the connector
R <sub>1</sub>	0	10 Ω	-	Recommended value
R <sub>2</sub> , R <sub>6</sub>	0	120 Ω	220 Ω	Recommended value

Table 68 - Recommended Values for the MLX90374 in SOIC-8 Package

## 14.2. Wiring with the MLX90374 in DMP-4 Package (built-in capacitors)

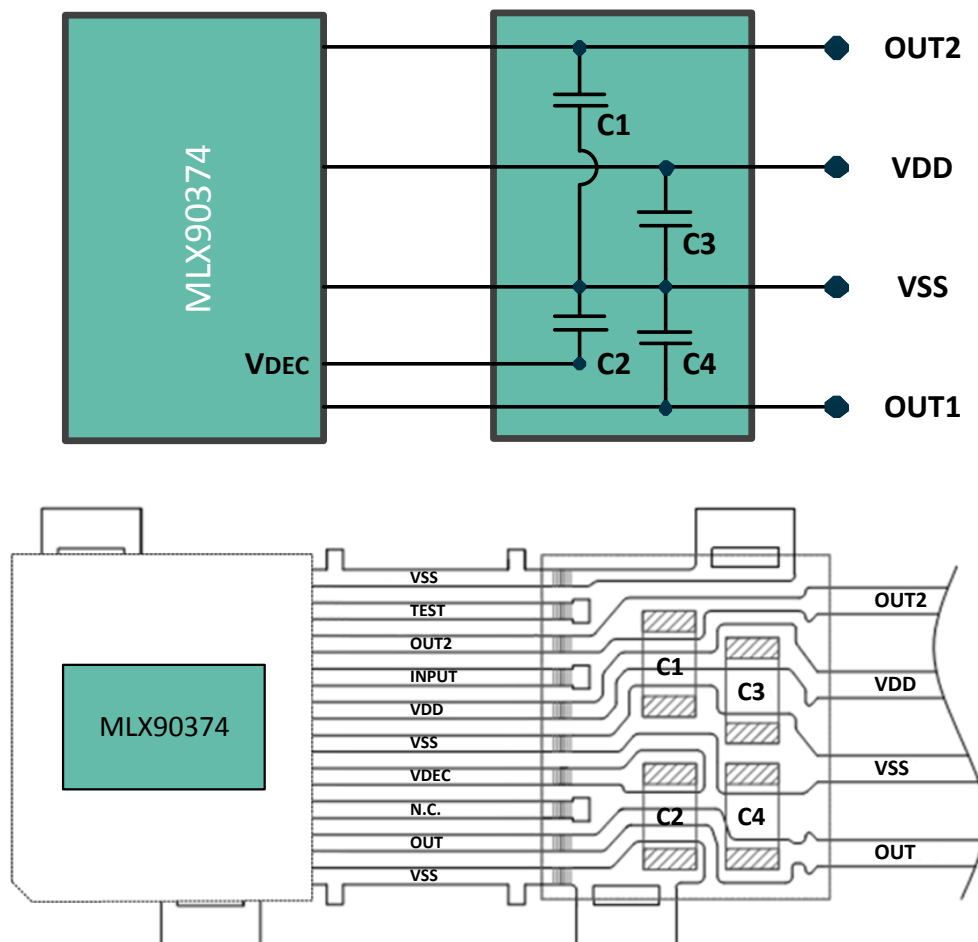

fig. 27 - Internal wiring of the MLX90374 in DMP-4

Component	Value	Remark
C1,C4	10.0 nF	Ordering code -10x, -20x, -30x
C2	220 nF	Ordering code -10x, -20x, -30x
C3	100 nF	Ordering code -10x, -20x, -30x

Table 69 - DMP-4 capacitors configuration

## 15. Standard information regarding manufacturability of Melexis products with different soldering processes

Our products are classified and qualified regarding soldering technology, solderability and moisture sensitivity level according to standards in place in Semiconductor industry.

For further details about test method references and for compliance verification of selected soldering method for product integration, Melexis recommends reviewing on our web site the General Guidelines soldering recommendation (<http://www.melexis.com/en/quality-environment/soldering>)

For all soldering technologies deviating from the one mentioned in above document (regarding peak temperature, temperature gradient, temperature profile etc), additional classification and qualification tests have to be agreed upon with Melexis.

For package technology embedding trim and form post-delivery capability, Melexis recommends consulting the dedicated trim & form recommendation application note : “Lead Trimming and Forming Recommendations” (<https://www.melexis.com/en/documents/documentation/application-notes/application-note-lead-trimming-and-forming-recommendations>).

Melexis is contributing to global environmental conservation by promoting lead free solutions. For more information on qualifications of RoHS compliant products (RoHS = European directive on the Restriction Of the use of certain Hazardous Substances) please visit the quality page on our website: <http://www.melexis.com/en/quality-environment>.

## 16. ESD Precautions

Electronic semiconductor products are sensitive to Electro Static Discharge (ESD).

Always observe Electro Static Discharge control procedures whenever handling semiconductor products.

## 17. Package Information

### 17.1. SOIC-8- Package Dimensions

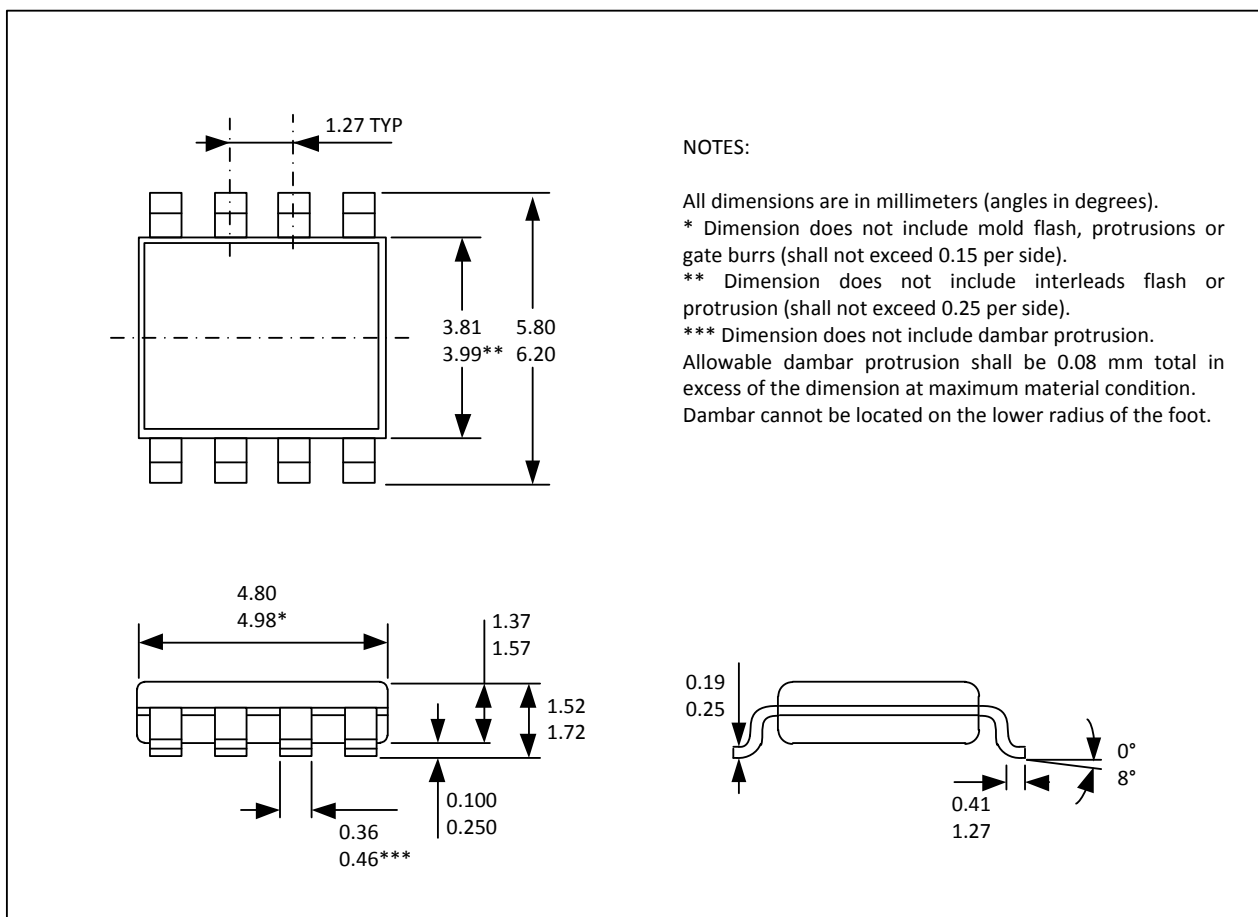

fig. 28 - SOIC-8 Package Outline Dimensions

### 17.2. SOIC-8- Pinout and Marking

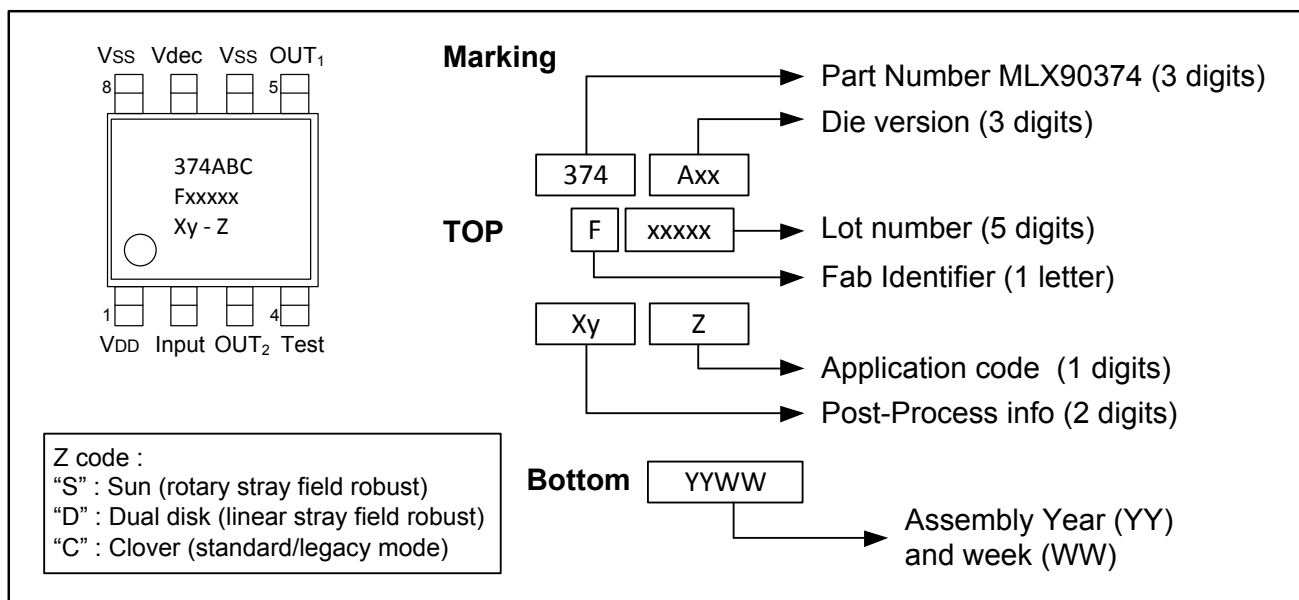

fig. 29 - SOIC-8 Pinout and Marking

### 17.3. SOIC-8- Sensitive spot positioning

#### 17.3.1. Rotary Stray-field Immune and Standard Mode Applications

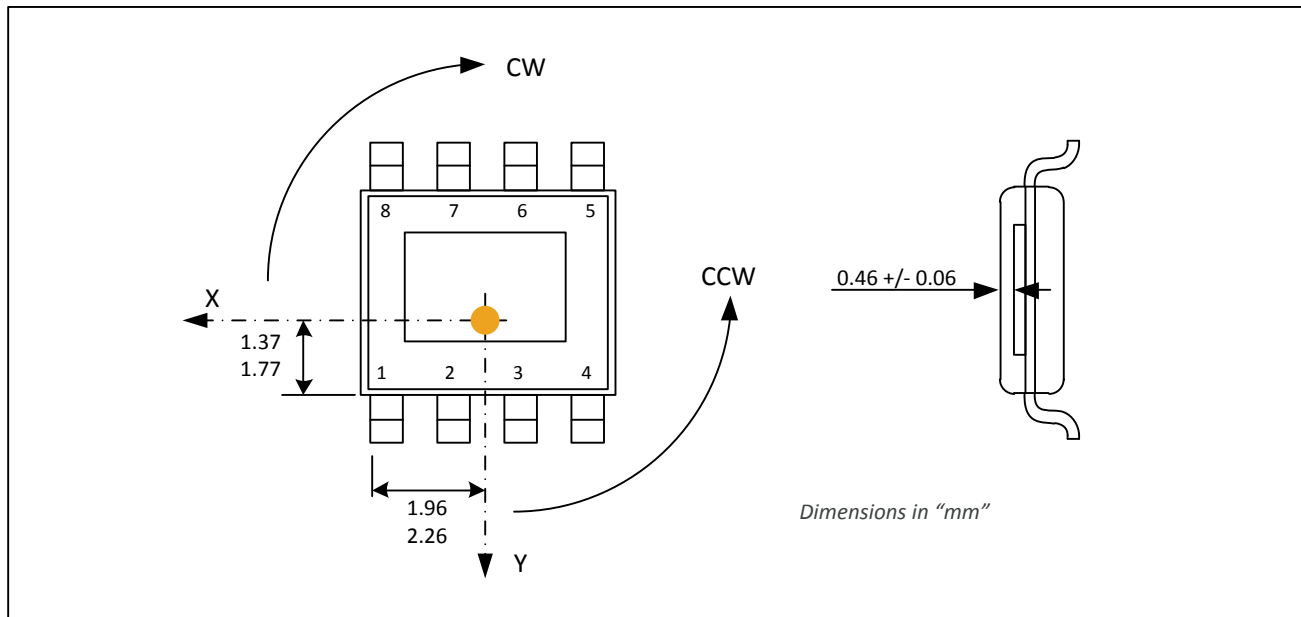

fig. 30 - SOIC-8 Sensitive Spot Position

#### 17.3.2. Linear Stray-field Immune Applications

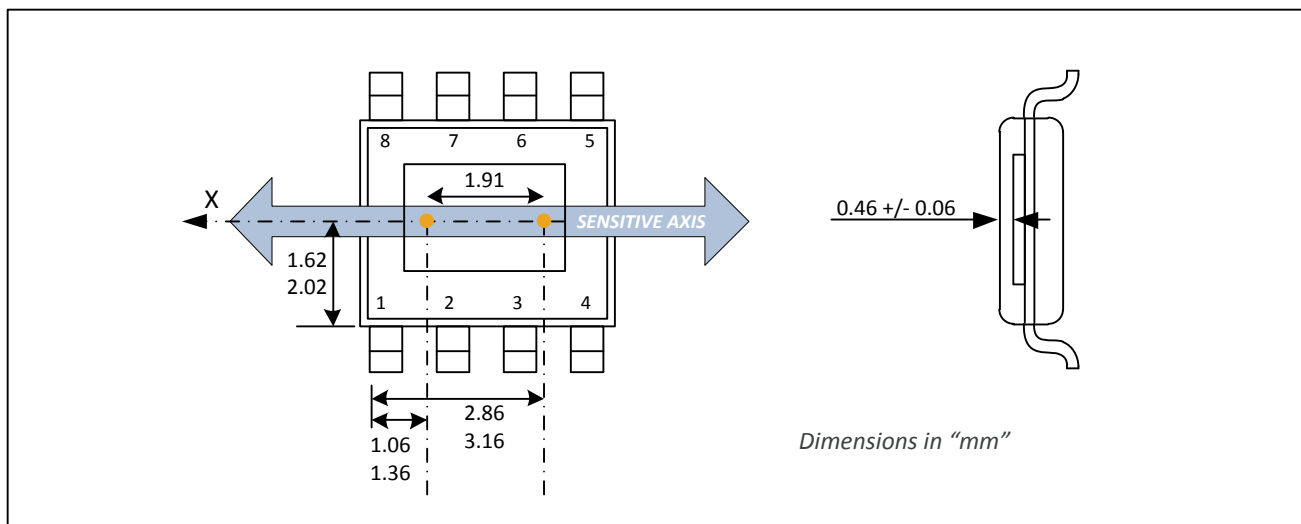
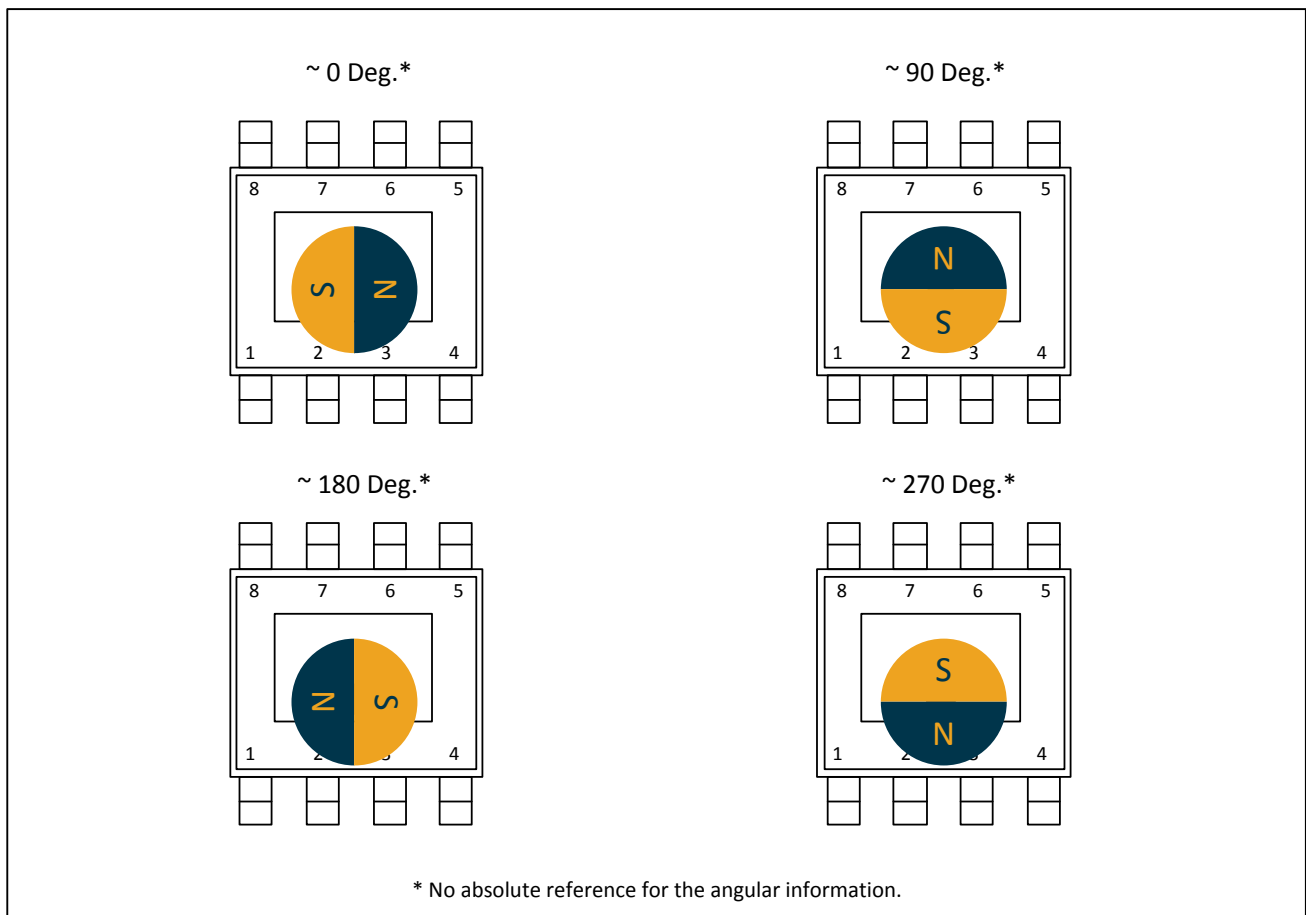

fig. 31 - SOIC-8 Sensitive Spot position for Linear Stray-Field Immune

## 17.4. SOIC-8- Angle detection



*fig. 32 - SOIC-8 Angle Detection*

The MLX90374 is an absolute angular position sensor but the linearity error (See section 8.1.1 ) does not include the error linked to the absolute reference 0 Deg (which can be fixed in the application through the discontinuity point).

### 17.5. DMP-4- Package Outline Dimensions (POD) STD1 1.27

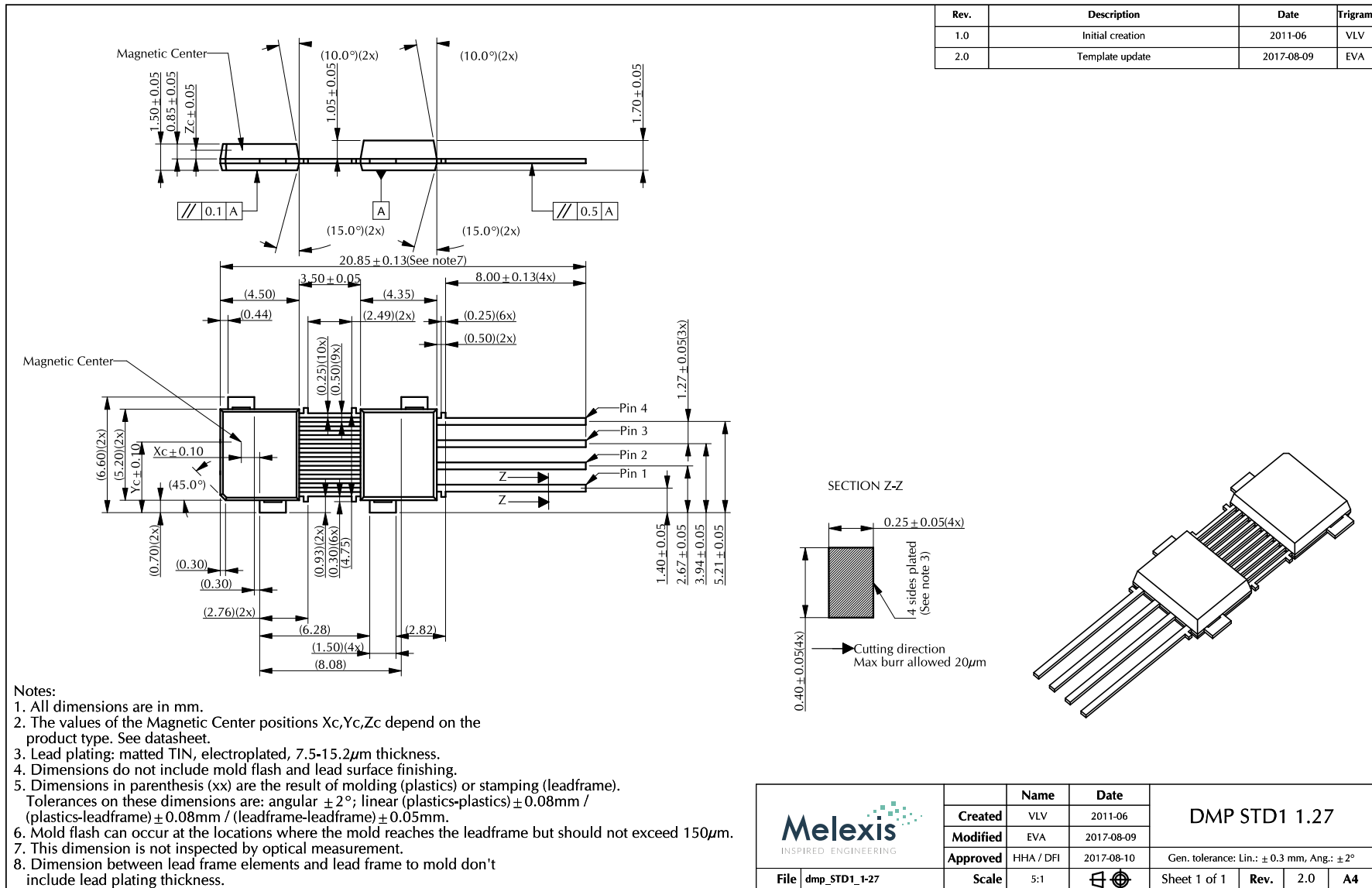

fig. 33 - DMP-4 Straight Leads Package Outline Drawing



### 17.6. DMP-4- Package Outline Dimensions (POD) STD3 2.00

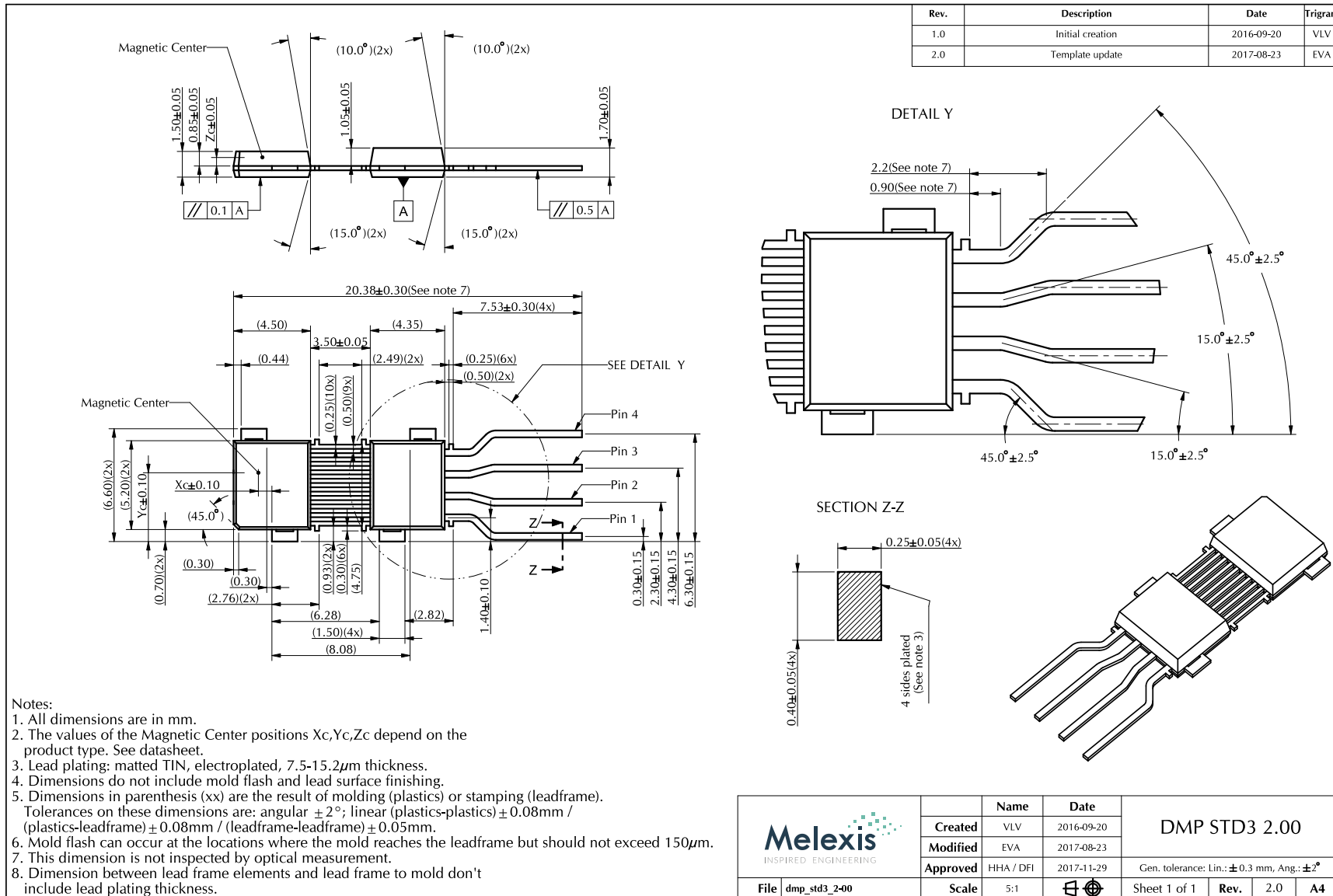

fig. 34 - DMP-4 STD3 2.00 Package Outline Drawing

## 17.7. DMP-4- Marking

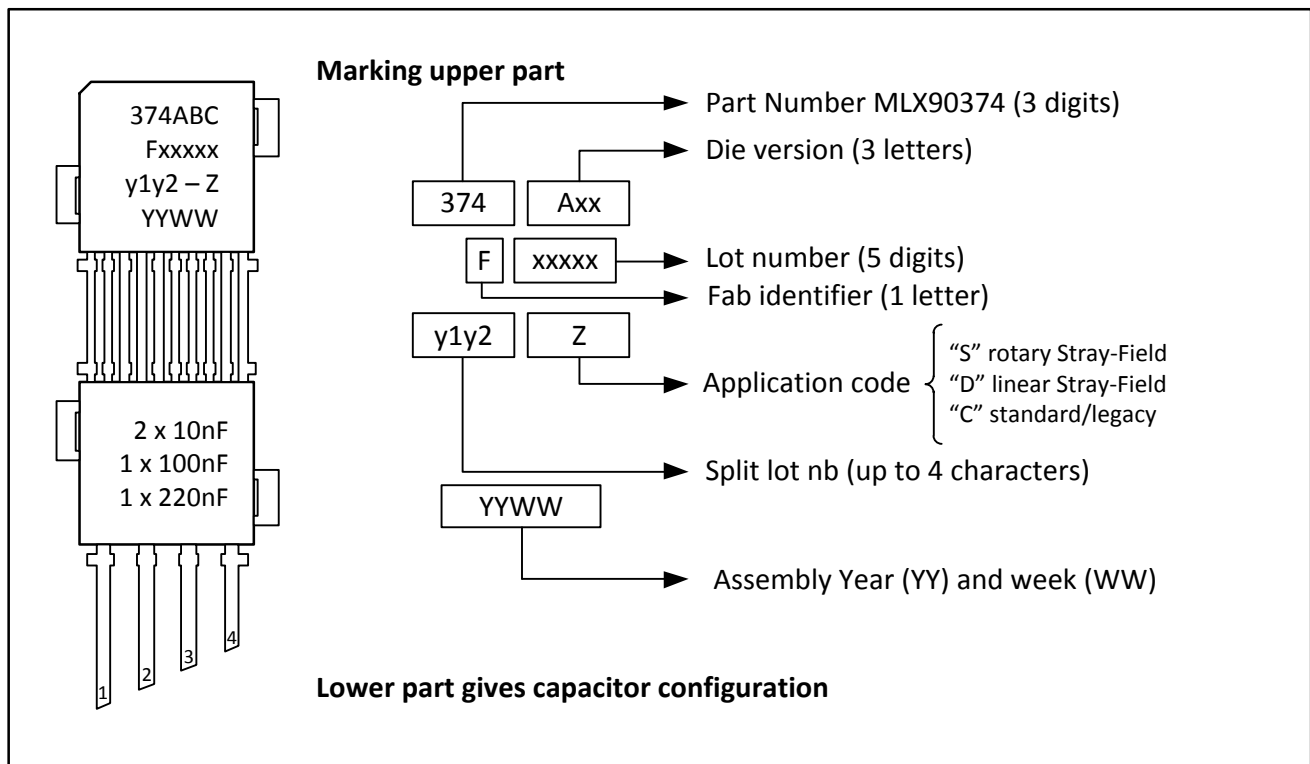

fig. 35 - DMP-4 Marking

## 17.8. DMP-4- Sensitive Spot Positioning

### 17.8.1. Rotary Stray-field Immune or Standard Mode Applications

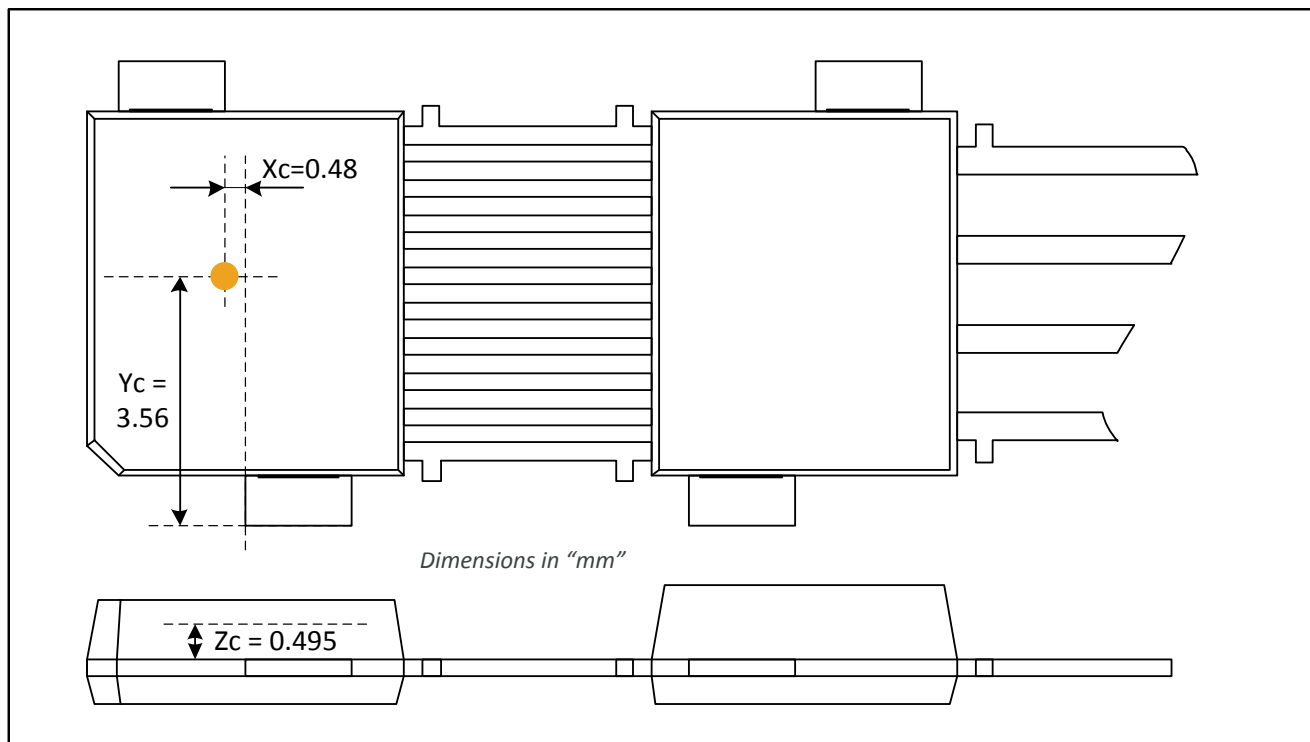

fig. 36 - DMP-4 Rotary Stray-field or legacy Sensitive Spot Position

### 17.8.2. Linear Stray-field Immune Applications

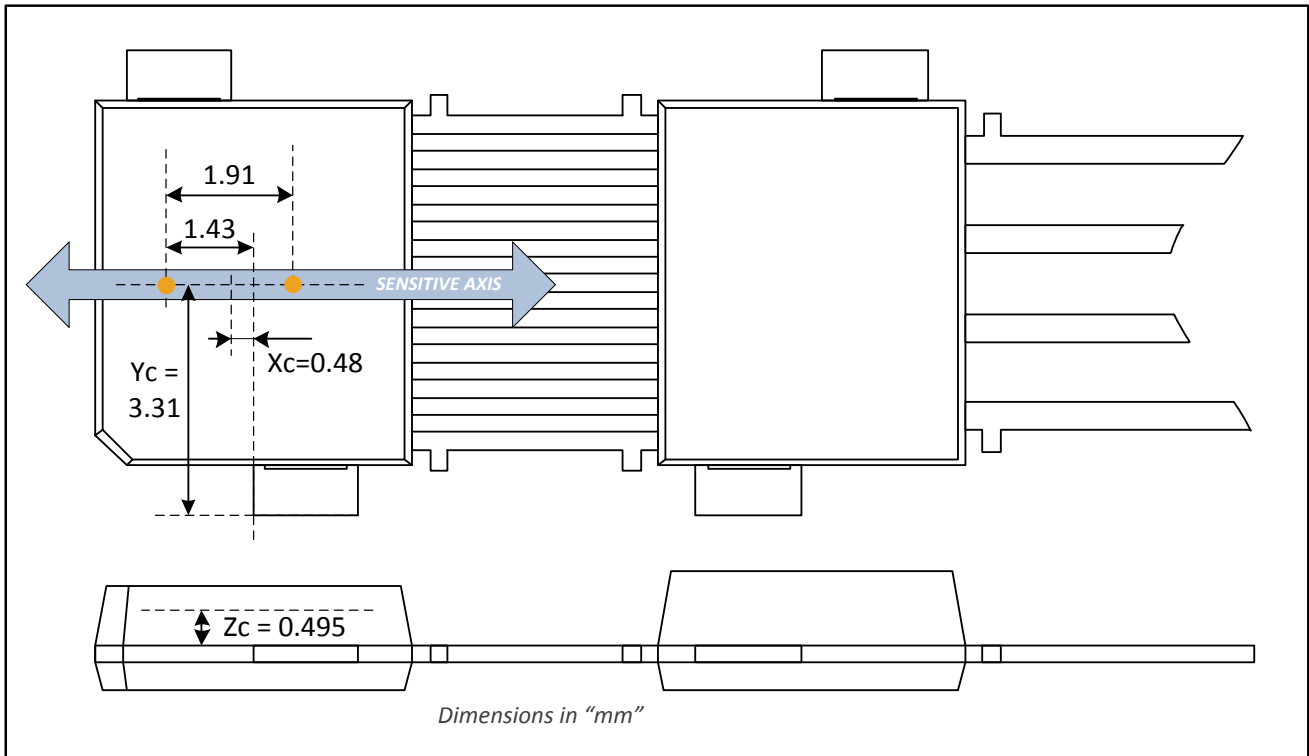

fig. 37 - DMP-4 Linear Stray-field Sensitive Spots Position

## 17.9. DMP-4- Angle detection

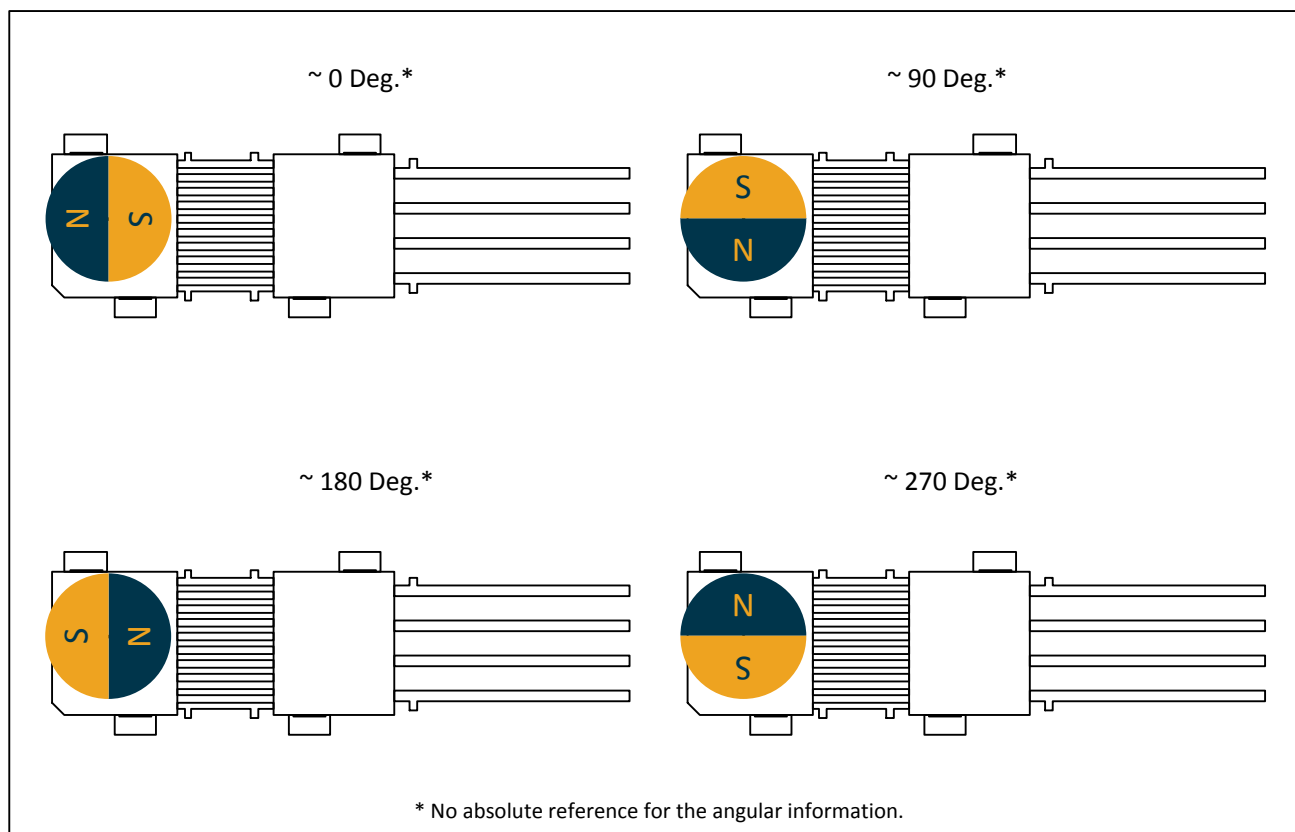

fig. 38 - DMP-4 Angle Detection

The MLX90374 is an absolute angular position sensor but the linearity error (See section 8.1.1 ) does not include the error linked to the absolute reference 0 Deg (which can be fixed in the application through the discontinuity point).

## 17.10. Packages Thermal Performances

The table below describe the thermal behaviour of available packages following JEDEC EIA/JESD 51.X standard.

Package	Junction to case - $\theta_{jc}$	Junction to ambient - $\theta_{ja}$ (JEDEC 1s2p board)	Junction to ambient - $\theta_{ja}$ (JEDEC 1s2p board)
SOIC-8	38.8 K/W	112 K/W	153 K/W
DMP-4	32.2 K/W	88.7 K/W	done without PCB <sup>(43)</sup>

Table 70 - Standard Packages Thermal Performances

<sup>43</sup> DMP-4 as PCB-less solution has been evaluated in a typical application case. Values for this package are given as informative.

## 18. Contact

For the latest version of this document, go to our website at [www.melexis.com](http://www.melexis.com).

For additional information, please contact our Direct Sales team and get help for your specific needs:

Europe, Africa	Telephone: +32 13 67 04 95
	Email : sales_europe@melexis.com
Americas	Telephone: +1 603 223 2362
	Email : sales_usa@melexis.com
Asia	Email : sales_asia@melexis.com

## 19. Disclaimer

*The information furnished by Melexis herein ("Information") is believed to be correct and accurate. Melexis disclaims (i) any and all liability in connection with or arising out of the furnishing, performance or use of the technical data or use of the product(s) as described herein ("Product") (ii) any and all liability, including without limitation, special, consequential or incidental damages, and (iii) any and all warranties, express, statutory, implied, or by description, including warranties of fitness for particular purpose, non-infringement and merchantability. No obligation or liability shall arise or flow out of Melexis' rendering of technical or other services.*

*The Information is provided "as is" and Melexis reserves the right to change the Information at any time and without notice. Therefore, before placing orders and/or prior to designing the Product into a system, users or any third party should obtain the latest version of the relevant information to verify that the information being relied upon is current.*

*Users or any third party must further determine the suitability of the Product for its application, including the level of reliability required and determine whether it is fit for a particular purpose.*

*The Information is proprietary and/or confidential information of Melexis and the use thereof or anything described by the Information does not grant, explicitly or implicitly, to any party any patent rights, licenses, or any other intellectual property rights.*

*This document as well as the Product(s) may be subject to export control regulations. Please be aware that export might require a prior authorization from competent authorities.*

*The Product(s) are intended for use in normal commercial applications. Unless otherwise agreed upon in writing, the Product(s) are not designed, authorized or warranted to be suitable in applications requiring extended temperature range and/or unusual environmental requirements. High reliability applications, such as medical life-support or life-sustaining equipment are specifically not recommended by Melexis.*

*The Product(s) may not be used for the following applications subject to export control regulations: the development, production, processing, operation, maintenance, storage, recognition or proliferation of 1) chemical, biological or nuclear weapons, or for the development, production, maintenance or storage of missiles for such weapons; 2) civil firearms, including spare parts or ammunition for such arms; 3) defense related products, or other material for military use or for law enforcement; 4) any applications that, alone or in combination with other goods, substances or organisms could cause serious harm to persons or goods and that can be used as a means of violence in an armed conflict or any similar violent situation.*

*The Products sold by Melexis are subject to the terms and conditions as specified in the Terms of Sale, which can be found at <https://www.melexis.com/en/legal/terms-and-conditions>.*

*This document supersedes and replaces all prior information regarding the Product(s) and/or previous versions of this document.*

*Melexis NV © - No part of this document may be reproduced without the prior written consent of Melexis. (2019)*

*ISO/TS 16949 and ISO14001 Certified*