

mikroBuffer PROTO™

Manual

All Mikroelektronika's development systems feature a large number of peripheral modules expanding microcontroller's range of application and making the process of program testing easier. In addition to these modules, it is also possible to use numerous additional modules linked to the development system through the I/O port connectors. Some of these additional modules can operate as stand-alone devices without being connected to the microcontroller.

Additional board

 **MikroElektronika**

SOFTWARE AND HARDWARE SOLUTIONS FOR EMBEDDED WORLD ...making it simple

mikroBuffer PROTO

The mikroBuffer PROTO additional board is used to amplify an analog voltage signal by using a unity gain amplifier. The amplified signal is then sent to the microcontroller analog inputs.

Key features:

- Analog signal unity gain;
- Low power consumption; and
- 3.3V or 5V power supply voltage.



Figure 1: mikroBuffer PROTO board

How to connect the board?

The mikroBuffer PROTO additional board can be easily connected to a microcontroller via a 1x6 connector CN1. Connectors CN2 and CN3 are used to establish connection between the board and a device that generates analog voltage signal to be amplified. The board is powered with 3.3V or 5V DC power supply voltage via the CN4 connector.

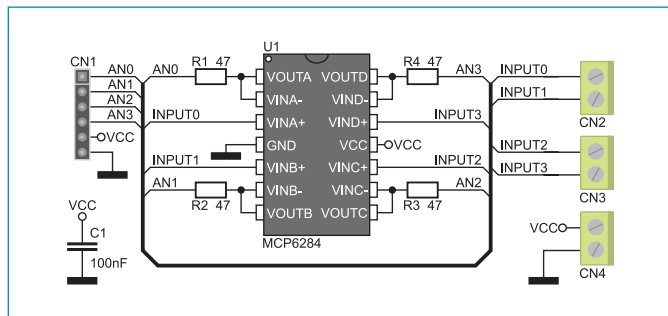

Figure 2: mikroBuffer PROTO board connection schematic

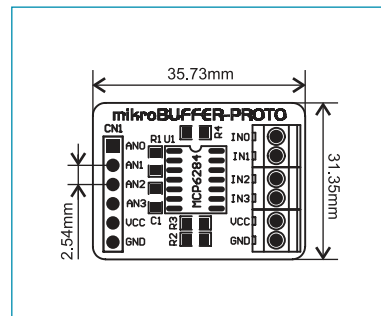

Figure 3: Dimensions of the board



MikroElektronika
SOFTWARE AND HARDWARE SOLUTIONS FOR EMBEDDED WORLD ...making it simple

If you want to learn more about our products, please visit our website at www.mikroe.com

If you are experiencing some problems with any of our products or just need additional information, please place your ticket at www.mikroe.com/en/support

If you have any questions, comments or business proposals, do not hesitate to contact us at office@mikroe.com