

Low Jitter Clock Generators for Set-Top Box

The ISL14010 series of devices are general purpose integrated Clock Synthesizers and Generators suited for consumer applications such as Set-top Box, and various other consumer applications.

The selectable reference input accepts 30MHz signal either from crystal or an external source. It is specified to operate with a nominal 3.3V supply and is offered in 16 Ld QFN package.

Contact Factory for other output frequency options.

Ordering Information

PART NUMBER	PART MARKING	TEMP. RANGE (°C)	PACKAGE	PKG. DWG. #
ISL14010IRZ*	10IZ	-40 to +85	16 LD QFN	L16.3x3
ISL14017IRZ*	17IZ	-40 to +85	16 LD QFN	L16.3x3

*Add "-T" suffix for tape and reel.

NOTE: Intersil Pb-free plus anneal products employ special Pb-free material sets; molding compounds/die attach materials and 100% matte tin plate termination finish, which are RoHS compliant and compatible with both SnPb and Pb-free soldering operations. Intersil Pb-free products are MSL classified at Pb-free peak reflow temperatures that meet or exceed the Pb-free requirements of IPC/JEDEC J STD-020.

Selection Table

PART OPTIONS	INPUT FREQUENCY	NUMBER OF OUTPUTS	OUTPUT FREQUENCY	PACKAGE
ISL14010	30MHz	4 LVTTTL	25, 30, 48, 54	16 LD QFN
ISL14017	30MHz	4 LVTTTL	25, 30, 40, 50	16 LD QFN

Features

- LVTTTL Outputs
- Selectable Crystal or Ref. Clock for Inputs
- Period Jitter ~50ps RMS
- Single Supply; 3.3V nominal
- Extended Temperature Range: -40°C to +85°C
- Available in small foot print package
 - 16 Ld QFN 3mmx3mm
- Pb-Free plus anneal available (RoHS Compliant)

Applications

- Set-Top Boxes

Pinout

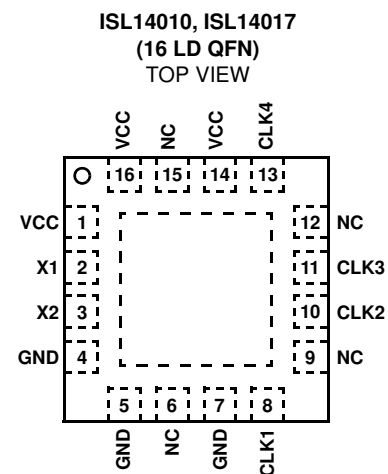

Functional Block Diagram

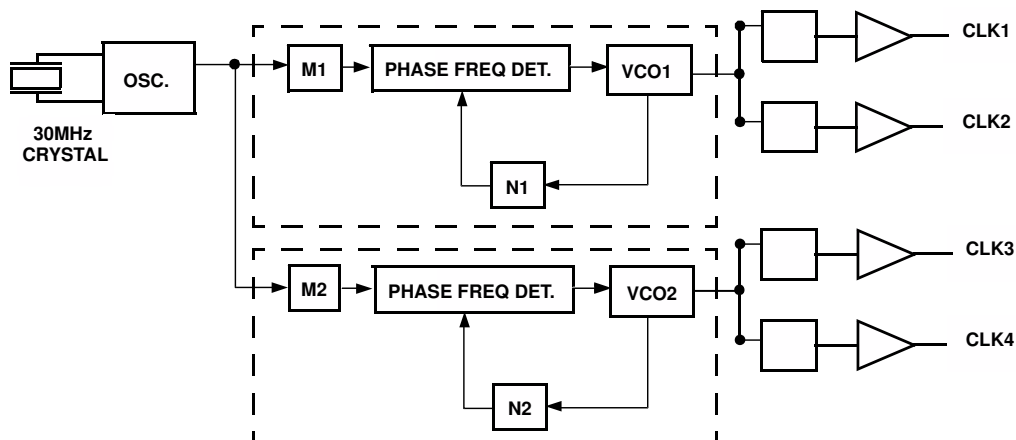

Pin Description

16 LD QFN	SYMBOLS	PIN DESCRIPTION
1,14,16	VCC	Supply Voltage
2	X1	The X1 pin is the terminal 1 of an external 30MHz crystal. This pin is grounded for external CK input.
3	X2	The X2 pin is the terminal 2 of external 30MHz crystal, or external clock input.
4, 5, 7	GND	Ground
8	CLK1	CLK1 Output: 25MHz
10	CLK2	CLK2 Output: 30MHz
11	CLK3	CLK3 Output: 48MHz (40MHz for ISL14017)
13	CLK4	CLK4 Output: 54MHz (50MHz for ISL14017)
6, 9, 12, 15	NC	No Connect

Typical Performance Curves (Period Jitter)

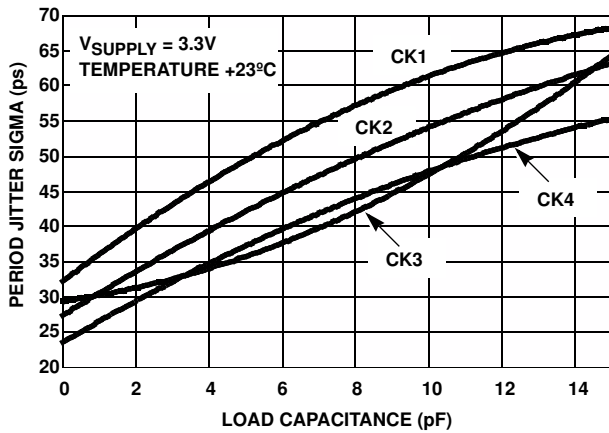

FIGURE 1. STANDARD DEVIATION vs LOAD CAPACITANCE

All Intersil U.S. products are manufactured, assembled and tested utilizing ISO9000 quality systems. Intersil Corporation's quality certifications can be viewed at www.intersil.com/design/quality

Intersil products are sold by description only. Intersil Corporation reserves the right to make changes in circuit design, software and/or specifications at any time without notice. Accordingly, the reader is cautioned to verify that data sheets are current before placing orders. Information furnished by Intersil is believed to be accurate and reliable. However, no responsibility is assumed by Intersil or its subsidiaries for its use; nor for any infringements of patents or other rights of third parties which may result from its use. No license is granted by implication or otherwise under any patent or patent rights of Intersil or its subsidiaries.

For information regarding Intersil Corporation and its products, see www.intersil.com

Package Outline Drawing

L16.3x3

16 LEAD QUAD FLAT NO-LEAD PLASTIC PACKAGE

Rev 2, 4/07

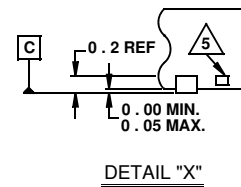
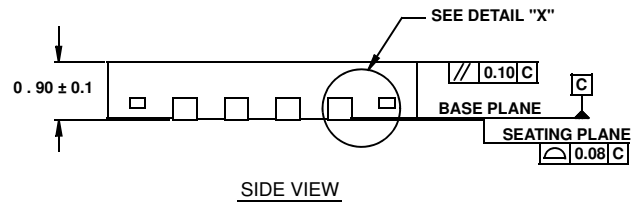
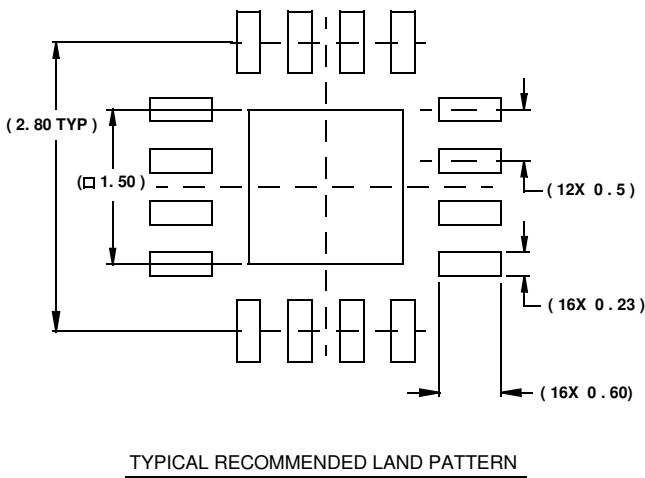
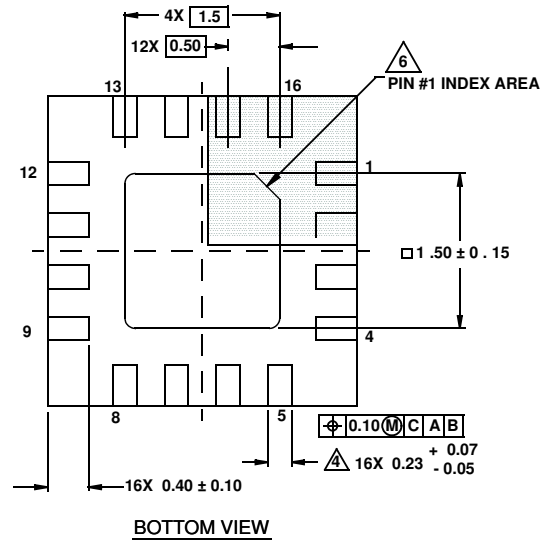
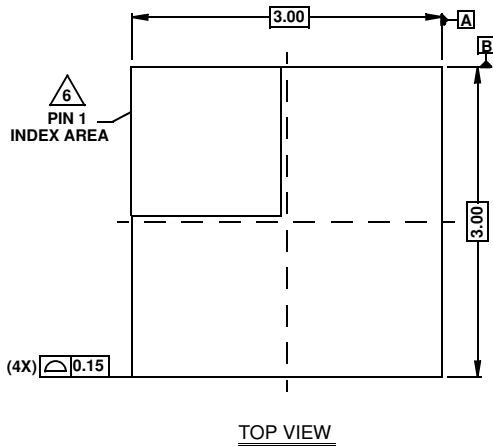

NOTES:

1. Dimensions are in millimeters.
Dimensions in () for Reference Only.
2. Dimensioning and tolerancing conform to AMSE Y14.5m-1994.
3. Unless otherwise specified, tolerance : Decimal ± 0.05
4. Dimension b applies to the metallized terminal and is measured between 0.15mm and 0.30mm from the terminal tip.
5. Tiebar shown (if present) is a non-functional feature.
6. The configuration of the pin #1 identifier is optional, but must be located within the zone indicated. The pin #1 identifier may be either a mold or mark feature.