

C3D08065A

3rd Generation 650 V, 8 A Silicon Carbide Schottky

Description

With the performance advantages of a Silicon Carbide (SiC) Schottky Barrier diode, power electronics systems can expect to meet higher efficiency standards than Si-based solutions, while also reaching higher frequencies and power densities. SiC diodes can be easily paralleled to meet various application demands, without concern of thermal runaway. In combination with the reduced cooling requirements and improved thermal performance of SiC products, SiC diodes are able to provide lower overall system costs in a variety of diverse applications.

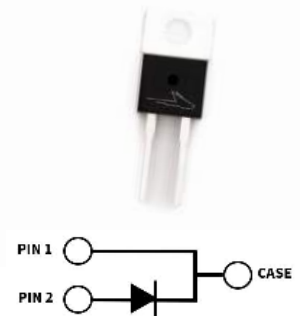

Package Types: TO-220-2
Marking: C3D08065A

Features

- Low Forward Voltage (V_F) Drop with Positive Temperature Coefficient
- Zero Reverse Recovery Current / Forward Recovery Voltage
- Temperature-Independent Switching Behavior

Applications

- Industrial Switched Mode Power Supplies
- Uninterruptible & AUX Power Supplies
- Boost for PFC & DC-DC Stages
- Solar Inverters

Maximum Ratings ($T_C = 25^\circ\text{C}$ Unless Otherwise Specified)

Parameter	Symbol	Value	Unit	Test Conditions	Notes
Repetitive Peak Reverse Voltage	V_{RRM}	650	V		
DC Blocking Voltage	V_{DC}	650			
Continuous Forward Current	I_F	24	A	$T_J = 25^\circ\text{C}$	Fig. 3
		11		$T_J = 135^\circ\text{C}$	
		8		$T_J = 152^\circ\text{C}$	
Repetitive Peak Forward Surge Current	I_{FRM}	37.5	A	$T_C = 25^\circ\text{C}, t_p = 10 \text{ ms}, \text{Half Sine Wave}$	
		25.5		$T_C = 110^\circ\text{C}, t_p = 10 \text{ ms}, \text{Half Sine Wave}$	
Non-Repetitive Forward Surge Current	I_{FSM}	71	A	$T_C = 25^\circ\text{C}, t_p = 10 \text{ ms}, \text{Half Sine Wave}$	Fig. 8
		60		$T_C = 110^\circ\text{C}, t_p = 10 \text{ ms}, \text{Half Sine Wave}$	
Non-Repetitive Peak Forward Surge Current	$I_{F,Max}$	650	A	$T_C = 25^\circ\text{C}, t_p = 10 \mu\text{s}, \text{Pulse}$	
		530		$T_C = 110^\circ\text{C}, t_p = 10 \mu\text{s}, \text{Pulse}$	
Power Dissipation	P_{tot}	107	W	$T_J = 25^\circ\text{C}$	Fig. 4
		46.5		$T_J = 110^\circ\text{C}$	

Electrical Characteristics

Parameter	Symbol	Typ.	Max.	Unit	Test Conditions	Notes
Forward Voltage	V_F	1.5	1.8	V	$I_F = 8 \text{ A}, T_j = 25 \text{ }^\circ\text{C}$	Fig. 1
		2.1	2.4		$I_F = 8 \text{ A}, T_j = 175 \text{ }^\circ\text{C}$	
Reverse Current	I_R	10	51	μA	$V_R = 650 \text{ V}, T_j = 25 \text{ }^\circ\text{C}$	Fig. 2
		12	204		$V_R = 650 \text{ V}, T_j = 175 \text{ }^\circ\text{C}$	
Total Capacitive Charge	Q_C	20		nC	$V_R = 650 \text{ V}, T_j = 25 \text{ }^\circ\text{C}$	Fig. 5
Total Capacitance	C	395		pF	$V_R = 0 \text{ V}, T_j = 25 \text{ }^\circ\text{C}, f = 1 \text{ MHz}$	

Typical Performance

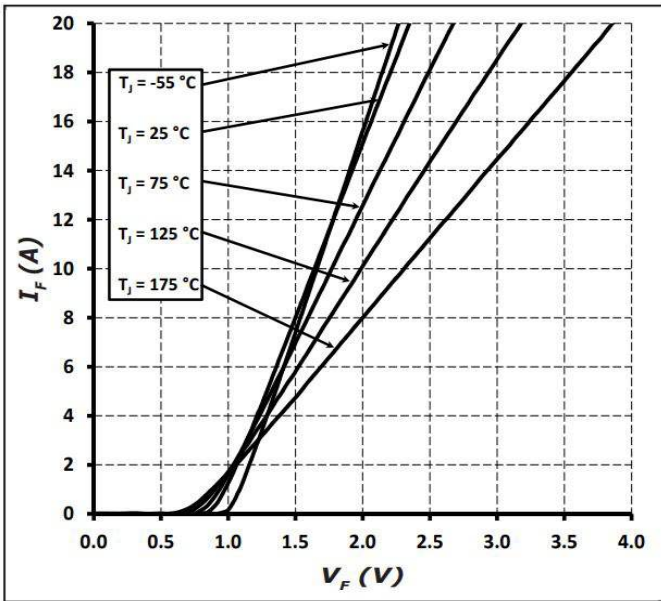

Figure 1
Forward Characteristics

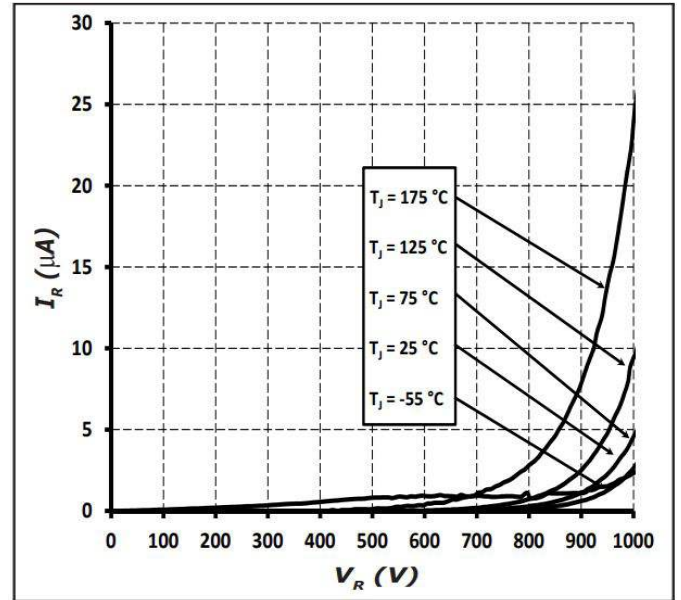

Figure 2
Reverse Characteristics

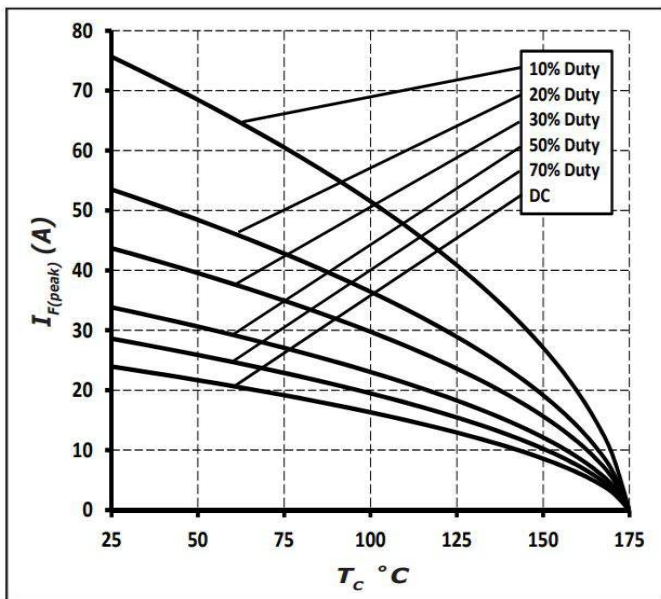

Figure 3
Current Derating

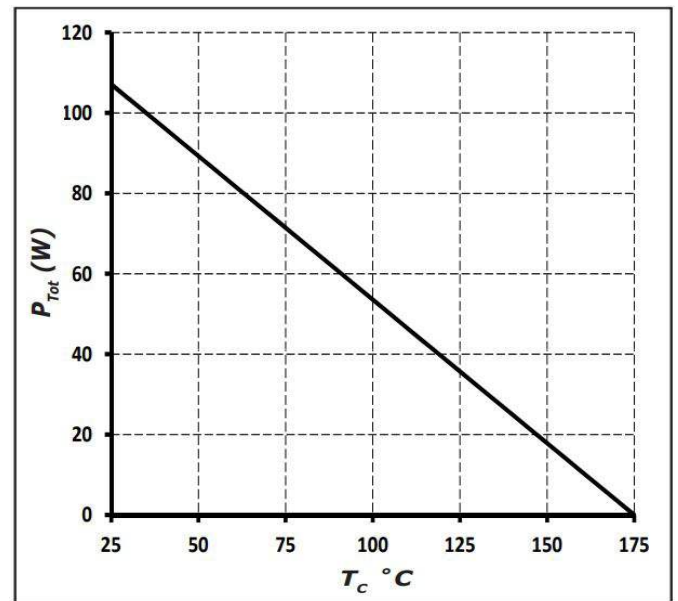

Figure 4
Power Derating

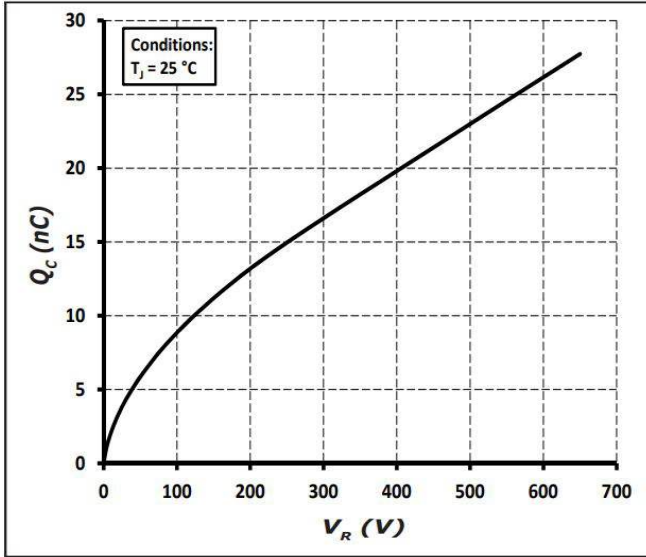

Figure 5

Total Capacitance vs. Reverse Voltage

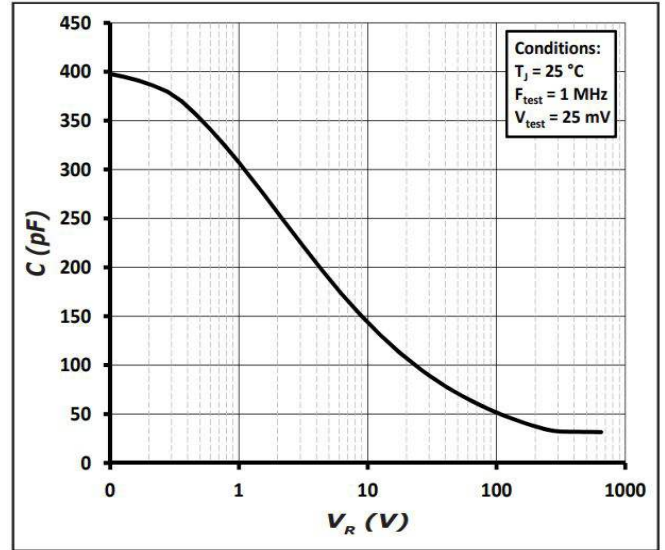

Figure 6

Capacitance vs. Reverse Voltage

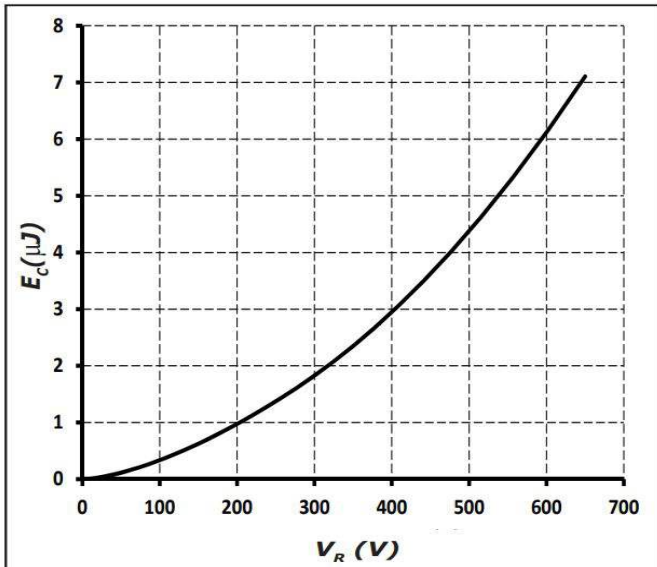

Figure 7

Capacitance Stored Energy

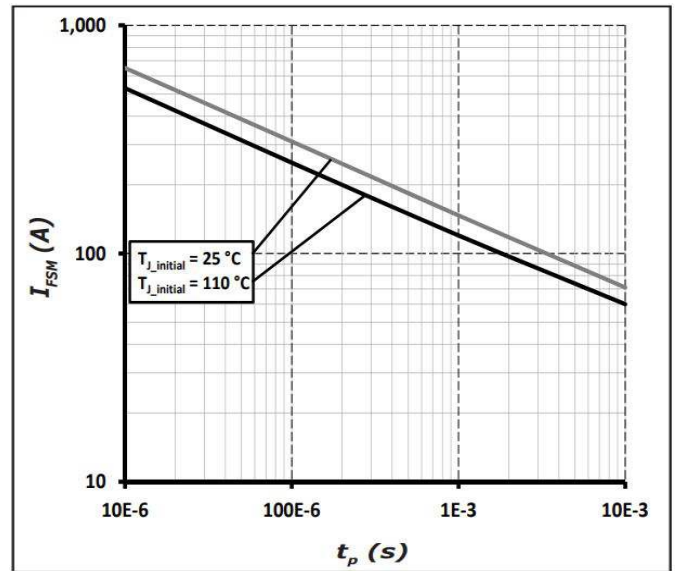

Figure 8

Non-Repetitive Peak Forward Surge Current versus Pulse Duration (sinusoidal waveform)

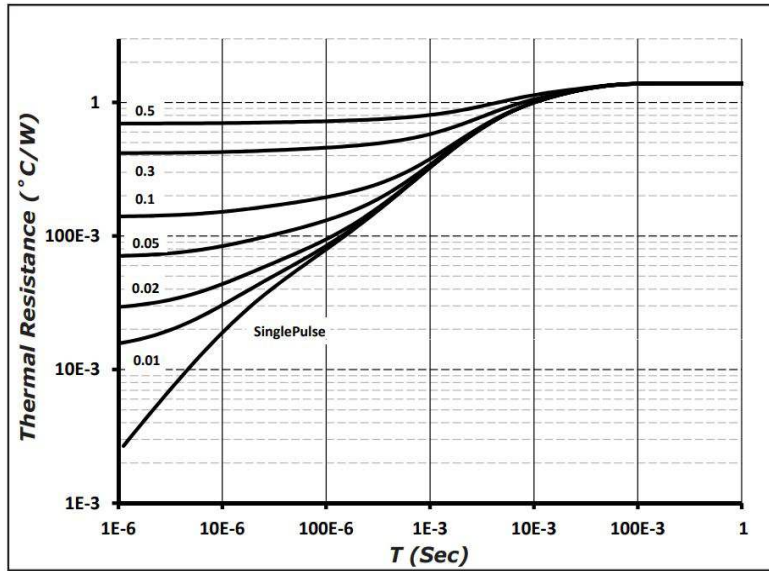
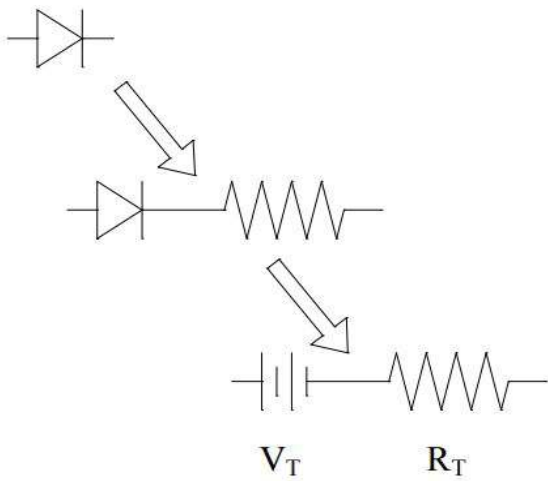

Figure 9
Transient Thermal Impedance

Diode Model



$$V_{f_T} = V_T + I_f * R_T$$

$$V_T = 0.95 + (T_J * -1.2 * 10^{-3})$$

$$R_T = 0.054 + (T_J * 5.5 * 10^{-4})$$

Note: T_J = Diode Junction Temperature In Degrees Celsius, valid from 25°C to 175°C

Package Dimensions & Pin-Out

Package: TO-220-2

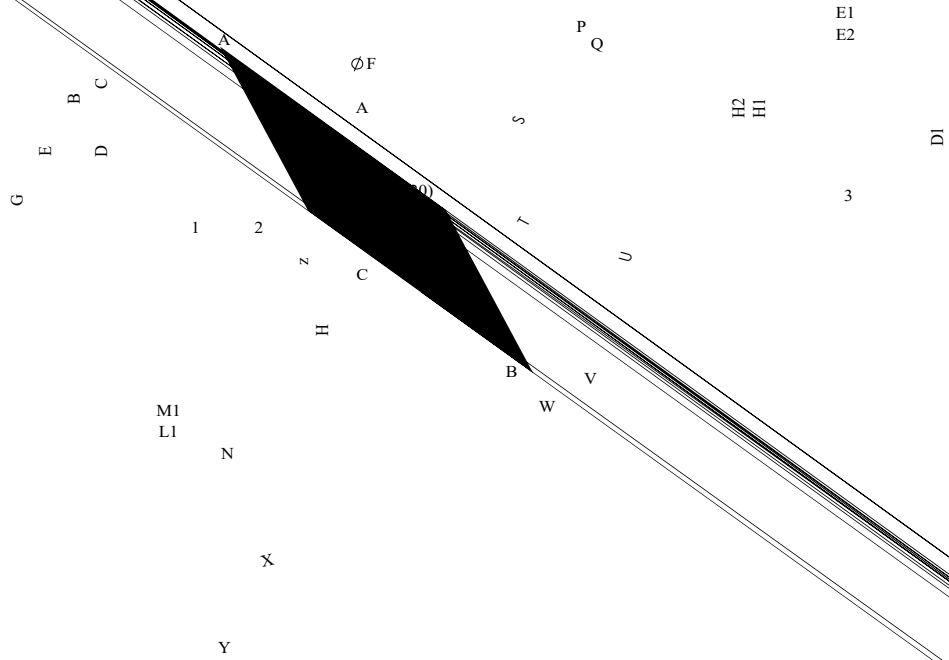

NOTE

- 1. ALL METAL SURFACES ARE TIN PLATED (MATTE), EXCEPT AREA OF CUT.
- 2. DIMENSIONING & TOLERANCING CONFORM TO ASME Y14.5M-1994.
- 3. ALL DIMENSIONS ARE LISTED IN MILLIMETERS. ANGLES ARE IN DEGREES.
- 4. PACKAGE BURR FLASH SIZE (0.5 mm) IS NOT INCLUDED IN THE DIMENSIONS



Recommended Solder Pad Layout

Primary dimensions shown in mm.

Learn more about recommended soldering profiles in [this application note](#).

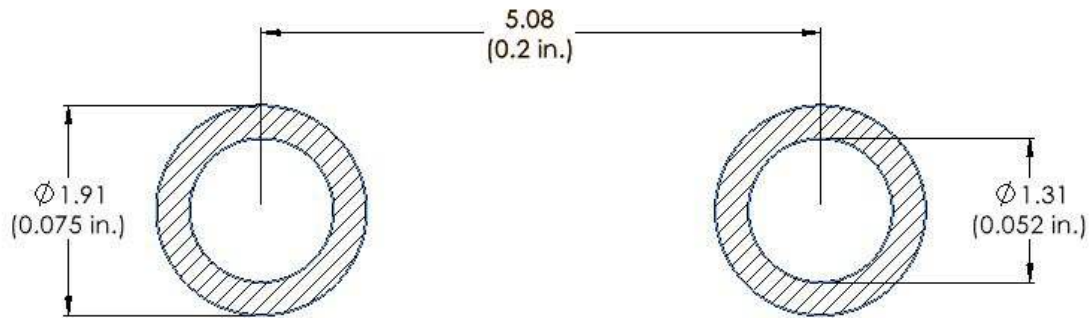

Product Ordering Information

Order Number	Packing Type
C3D08065A	Tube

Learn more about power device packing & shipment information in [this application note](#).



Revision History

Document Version	Date of Release	Description of Changes
1	December-2015	Initial Release
6	March-2023	Update Package Drawing Update Landing Pad



Notes & Disclaimer

This document and the information contained herein are subject to change without notice. Any such change shall be evidenced by the publication of an updated version of this document by Wolfspeed. No communication from any employee or agent of Wolfspeed or any third party shall effect an amendment or modification of this document. No responsibility is assumed by Wolfspeed for any infringement of patents or other rights of third parties which may result from use of the information contained herein. No license is granted by implication or otherwise under any patent or patent rights of Wolfspeed.

Notwithstanding any application-specific information, guidance, assistance, or support that Wolfspeed may provide, the buyer of this product is solely responsible for determining the suitability of this product for the buyer's purposes, including without limitation for use in the applications identified in the next bullet point, and for the compliance of the buyers' products, including those that incorporate this product, with all applicable legal, regulatory, and safety-related requirements.

This product has not been designed or tested for use in, and is not intended for use in, applications in which failure

Contact info:

4600 Silicon Drive
Durham, NC 27703 USA
Tel: +1.919.313.5300
www.wolfspeed.com/power