

THIS DRAWING IS UNPUBLISHED. RELEASED FOR PUBLICATION
 © COPYRIGHT 2005 BY TYCO ELECTRONICS CORPORATION. ALL RIGHTS RESERVED.

LOC	DIST	REVISIONS					
		P	LTR	DESCRIPTION	DATE	DWN	APVD
AJ	16		W1	REVISED PER ECO-06-018708	29AUG2006	MC	JL
			W2	REVISED PER ECO-09-020932	04SEP09	KK	AEQ

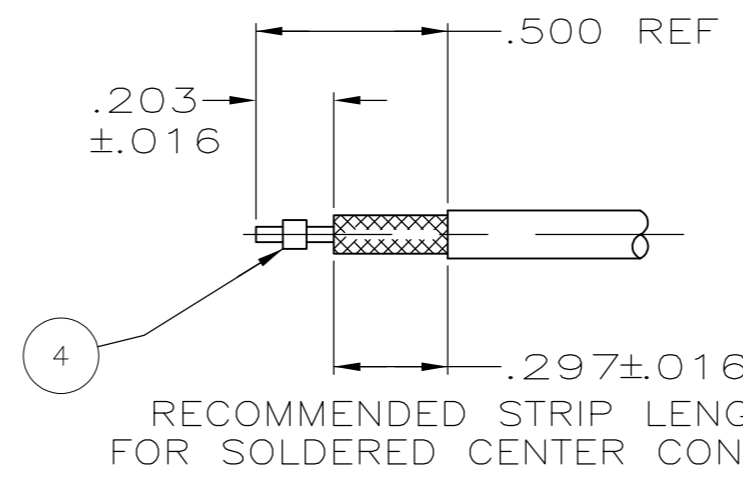
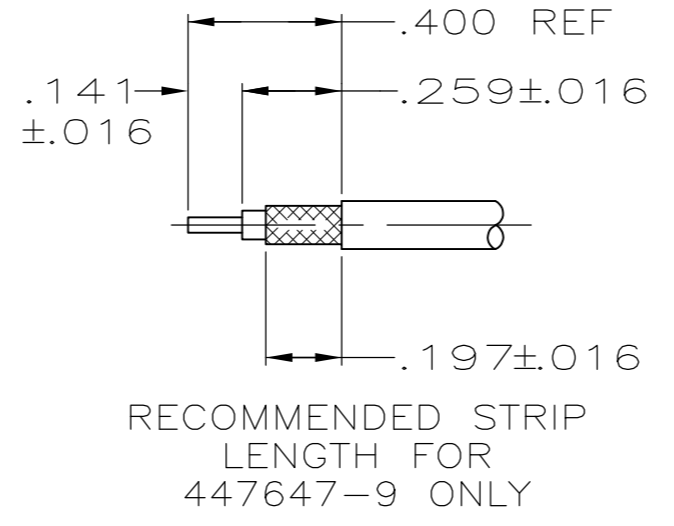
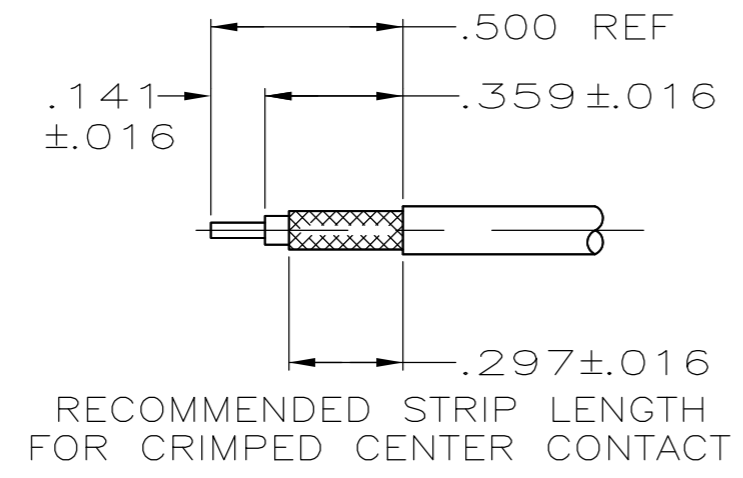
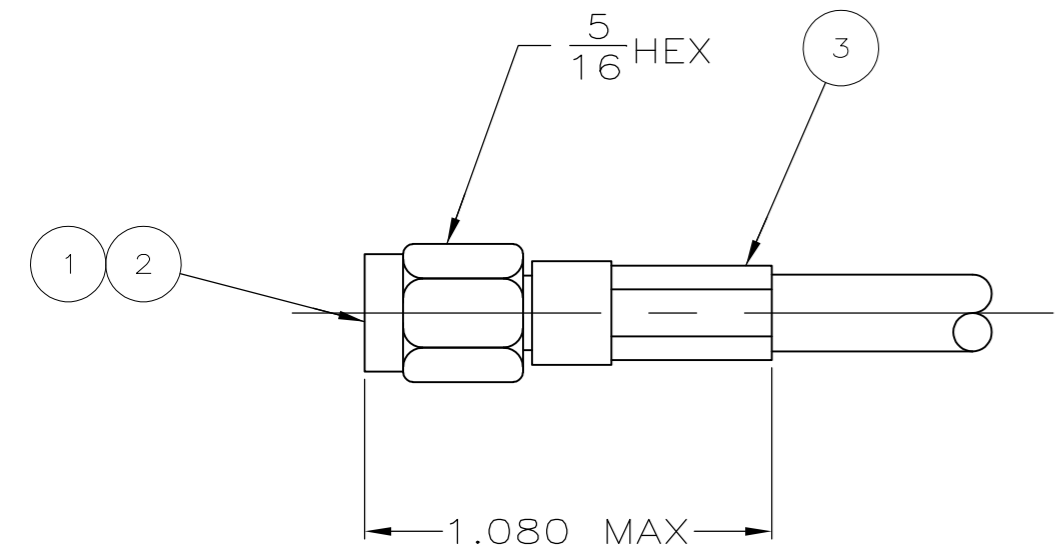

1. CENTER CONTACT: CRIMPING TOOL M22520/2-01; POSITIONER M22520/2-20; SELECTOR SETTING PER TABLE
2. FERRULE: CRIMPING TOOL M22520/5-01; DIE NUMBER OR HEX SIZE PER TABLE
3. PRODUCT IS DESIGNED TO MEET PRODUCT SPECIFICATION 108-1574.
4. BRIGHT NICKEL PLATE.
5. APPLIES TO 447647-5 ONLY.
6. COUPLING NUT MUST WITHSTAND 60 LB RETENTION FORCE. ALSO 15 IN-LB TORQUE WHEN MATED.
7. GOLD PLATE.
8. USE SELECTOR SETTING #7 FOR RG-142, 142A, 142B AND SELECTOR SETTING #6 FOR RG-400
9. INSTRUCTION SHEET: 408-4032
10. OBSOLETE PARTS: OBSOLETE CIS STREAMLINING PER D.RENAUD/D.SINISI

OBSOLETE	RG-174, 188 A, 316	DIE M22520/5-35 B OR .128X.400 HEX	#4	4	BRASS		9-446556-1	447869-2	447844-4	9-447647-1
OBSOLETE	RG-142, 142 A, 142 B, RG-400	DIE M22520/5-11 A OR .213X.400 HEX	8	4	BRASS		9-446556-0	443246-2	447844-1	9-447647-0
OBSOLETE	RG-174, 188 A, 316	DIE M22520/5-35 B OR .128X.400 HEX	#4	7	BRASS		4-446556-1	447869-2	447844-6	1-447647-4
OBSOLETE	BELDEN YR20621, CRIMPED/SOLDERED CONTACT	DIE M22520/5-11 A OR .213X.400 HEX	#5	7	BRASS	447863-1	4-446556-0	443246-2	447844-5	1-447647-3
OBSOLETE	RG-142, 142 A, 142 B, RG-400	DIE M22520/5-11 A OR .213X.400 HEX	8	4	BRASS		3-446566-6	443246-2	447844-1	1-447647-2
OBSOLETE	BELDEN YR20621, CRIMPED/SOLDERED CONTACT	DIE M22520/5-11 A OR .213X.400 HEX	#5	4	BRASS	447863-1	4-446556-4	443246-2	447844-7	1-447647-1
OBSOLETE	RG-55, 55 A, 55 B, 223	DIE M22520/5-11 A OR .213X.400 HEX	#7	4	BRASS		9-446556-3	447848-2	447844-1	1-447647-0
OBSOLETE	RG-174, 188 A, 316	DIE M22520/5-35 B OR .128X.400 HEX	#4	4	BRASS		3-446556-3	447869-2	447844-4	447647-9
OBSOLETE	RG-174 DB, RG-188 DB, RG-316 DB	DIE M22520/5-35 B OR .128X.400 HEX	#4	PASSIVATED	STAINLESS STEEL		2-446556-4	447869-2	447844-3	447647-8
OBSOLETE	RG-142, 142 A, 142 B, RG-400, CRIMPED/SOLDERED CONTACT	DIE M22520/5-11 A OR .213X.400 HEX	8	PASSIVATED	STAINLESS STEEL		3-446556-6	443246-2	447844-8	447647-7
OBSOLETE	RG-316, CRIMPED/SOLDERED CONTACT	DIE M22520/5-35 B OR .128X.400 HEX	#4	PASSIVATED	STAINLESS STEEL		9-446556-1	447869-2	447844-3	447647-6
SUPERSEDED	BELDEN YR20621, CRIMPED/SOLDERED CONTACT	DIE M22520/5-11 A OR .213X.400 HEX	#5	PASSIVATED	STAINLESS STEEL	447863-1	4-446556-4	443246-2	447844-2	447647-5
OBSOLETE	RG-188 Double Braid, 316 Double Braid	DIE M22520/5-35 B OR .128X.400 HEX	#4	4	BRASS		4-446556-3	447869-2	447844-4	447647-4
	RG-174, 188 A, 316	DIE M22520/5-35 B OR .128X.400 HEX	#4	4	BRASS		9-446556-1	447869-2	447844-4	447647-3
	RG-142, 142 A, 142 B, RG-400	DIE M22520/5-11 A OR .213X.400 HEX	8	4	BRASS		9-446556-0	443246-2	447844-1	447647-2
OBSOLETE	RG-58, 58 A/U, 58 B/U, 58 C/U	DIE M22520/5-11 A OR .213X.400 HEX	#5	4	BRASS		9-446556-2	443246-2	447844-1	447647-1
	CABLE SIZE	2? DIE # OR HEX SIZE	1? SELECTOR SETTING	FINISH	MATERIAL	4 SPACER QTY=1	3 FERRULE QTY=1	2 CONTACT QTY=1	1 PLUG ASSY QTY=1	PART NUMBER
				SHELL						

THIS DRAWING IS A CONTROLLED DOCUMENT.

DWN	BRENT D. YOHN	11OCT93
CHK	LANG LE	27OCT93
APVD	R. FISHER	27OCT93
PRODUCT SPEC	108-1574	
APPLICATION SPEC		
WEIGHT	-	
CUSTOMER DRAWING		

tyco Tyco Electronics Corporation
 Harrisburg, PA 17105-3608

NAME: CONNECTOR, PLUG, SMA, HEX CRIMP, COMMERCIAL

SIZE: A2 CAGE CODE: 00779 DRAWING NO: 447647 RESTRICTED TO: -

SCALE: 1:1 SHEET: 1 OF 1 REV: W2