



RFM Integrated Device, Inc.

PRODUCT SPECIFICATION

Part Number: XO6011

XO,100M +/-50 -40C to +85C
LVPECL

SMD 3.2x2.5 100 MHz Crystal Oscillator



Features:

- Surface Mount Seam Weld Package
- Excellent Reliability Performance
- Good Frequency Perturbation and Stability over temperature

Application:

- 3.3 V Supply Voltage LVPECL Output
- Option-able stand-by function for output .

Electrical Characteristics:

XO6011	Specifications
Nominal Frequency, Fo	100.000000 MHz
Storage Temperature Range	-55°C to +125°C
Operating Temperature Range	-40°C to +85°C
Power Supply Voltage, Vcc	3.3 V +/- 5%
Load	50 ohm (LVPECL)
“0” Level “1” Level	Vcc – 1.625 V max Vcc – 1.025 V min
Output Voltage Swing	750 mV typ.
Power Supply Current, Icc	30 mA typ. and 50 mA max
Frequency Tolerance	+/-50 ppm max
Duty Cycle	45% ~ 55%
Star-up Time	5.0 msec typ. , 10 msec max
RMS Phase Jitter (12K~20MHz)	0.2 ps typ. , 0.5 ps max
Rise Time (20% -> 80% of final RF level in Vp-p) Fall Time (80% -> 20% of final RF level in Vp-p)	0.3 nsec typ. , 0.5 nsec max. 0.3 nsec typ. , 0.5 nsec max.
Aging	+/-3 ppm/ 1 year
SSB Phase Noise (@10Hz Carrier Offset)	-50 dBc/Hz typ
SSB Phase Noise (@100Hz Carrier Offset)	-80 dBc/Hz typ
SSB Phase Noise (@1KHz Carrier Offset)	-115 dBc/Hz typ
SSB Phase Noise (@10KHz Carrier Offset)	-133 dBc/Hz typ
SSB Phase Noise (@1MHz Carrier Offset)	-142 dBc/Hz typ
SSB Phase Noise (@10MHz Carrier Offset)	-152 dBc/Hz typ

Enable/Disable Function	PIN 1: High or Open, PIN 3:Output Enable PIN 1: Low, PIN 3:Output Disable
-------------------------	--

#Note 1: Frequency accuracy includes 25C tolerance, operating temperature range -40 to 85deg C, aging and voltage or load change

Mechanical Dimensions: (Unit: mm)

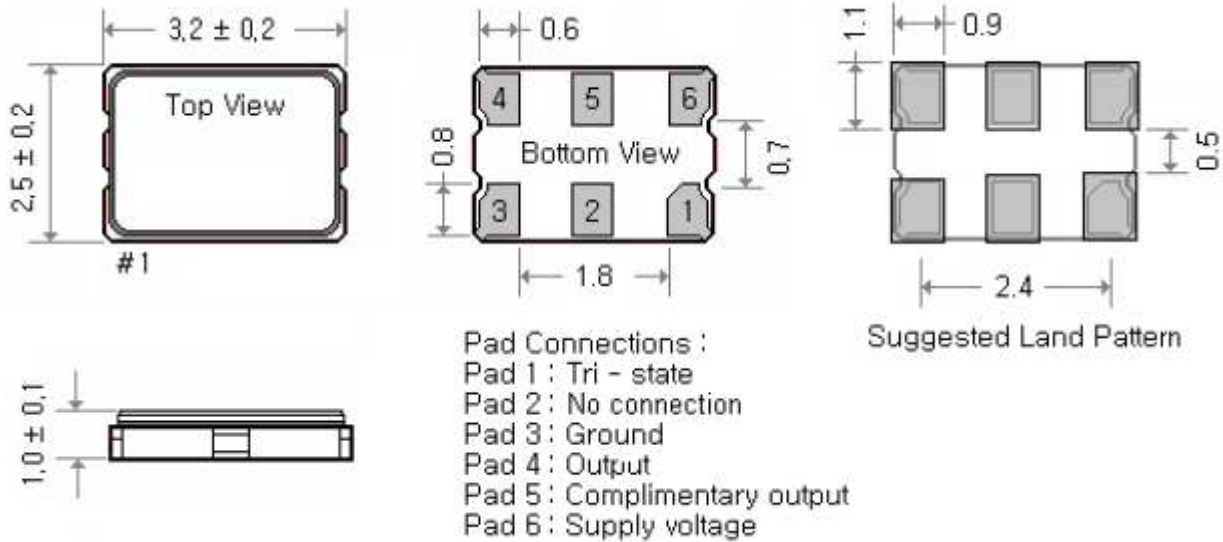

Marking :

Line 1 : Frequency (100.000)

Line 2 : $\text{\textcircled{T}}$ WDXX (Product Code + Date Code + Internal Traceability Code (XX) : Can be 1 or 2 letters)

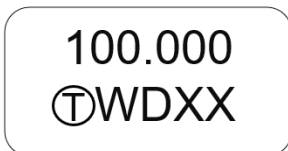

Product Code Table

Year	2013	2014	2015	2016
	2017	2018	2019	2020
	2021	2022	2023	2024
Product code	W	w	<u>W</u>	<u>w</u>

Date Code Table

WK01	WK02	WK03	WK04	WK05	WK06	WK07	WK08	WK09	WK10	WK11	WK12	WK13
A	B	C	D	E	F	G	H	I	J	K	L	M
WK14	WK15	WK16	WK17	WK18	WK19	WK20	WK21	WK22	WK23	WK24	WK25	WK26
N	O	P	Q	R	S	T	U	V	W	X	Y	Z
WK27	WK28	WK29	WK30	WK31	WK32	WK33	WK34	WK35	WK36	WK37	WK38	WK39
a	b	c	d	e	f	g	h	i	j	k	l	m
WK40	WK41	WK42	WK43	WK44	WK45	WK46	WK47	WK48	WK49	WK50	WK51	WK52
n	o	p	q	r	s	t	u	v	w	x	y	z

Packing:

■ Reel Dimension (Unit: mm)

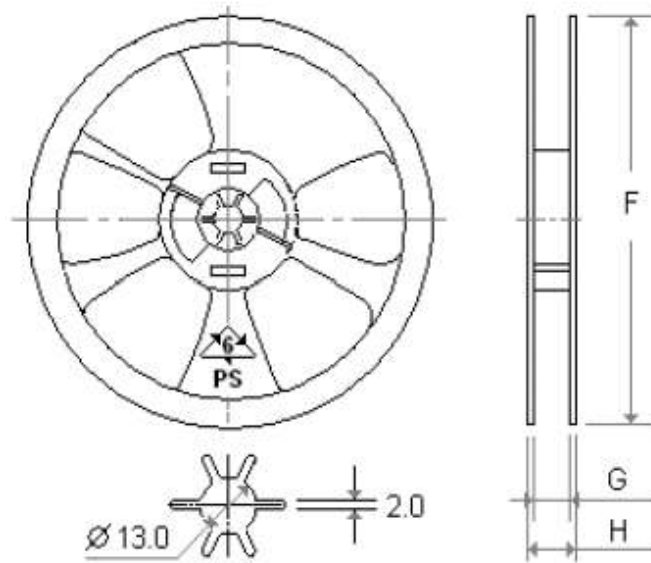

F	G	H
180.0	12.8	17

■ Tape Dimension (Unit: mm)

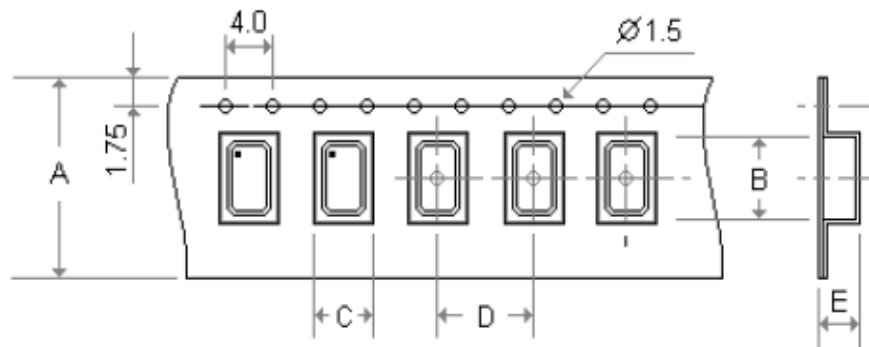

A	B	C	D	E
8.0	3.8	2.8	4.0	1.4

[NOTE]:

1. Unless otherwise specified tolerance on dimension +/-0.1 mm.
2. Material: conductive polystyrene with color black
3. 10 pitch cumulative tolerance +/-0.2 mm.
4. Packing Direction: dot or the logo of marking should be close to the hole of tape.

■ PACKING DIRECTION:

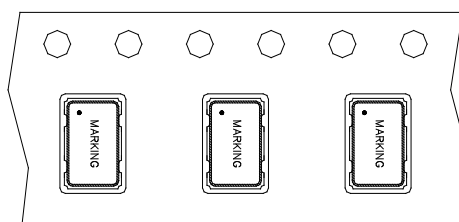

Packing Quantity/Packing: 1K pcs maximum per reel

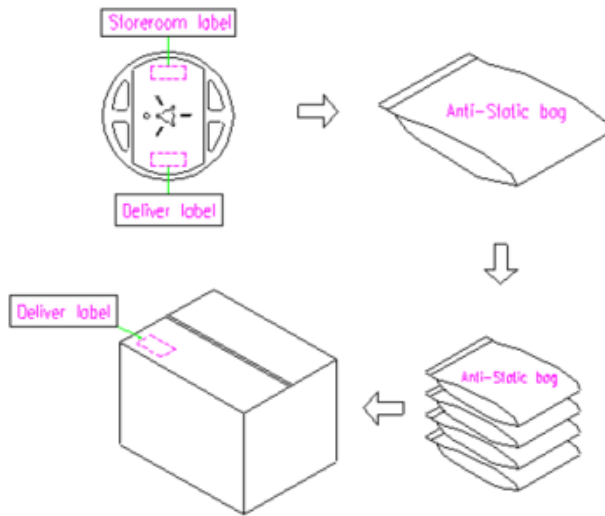

Reflow Profile:

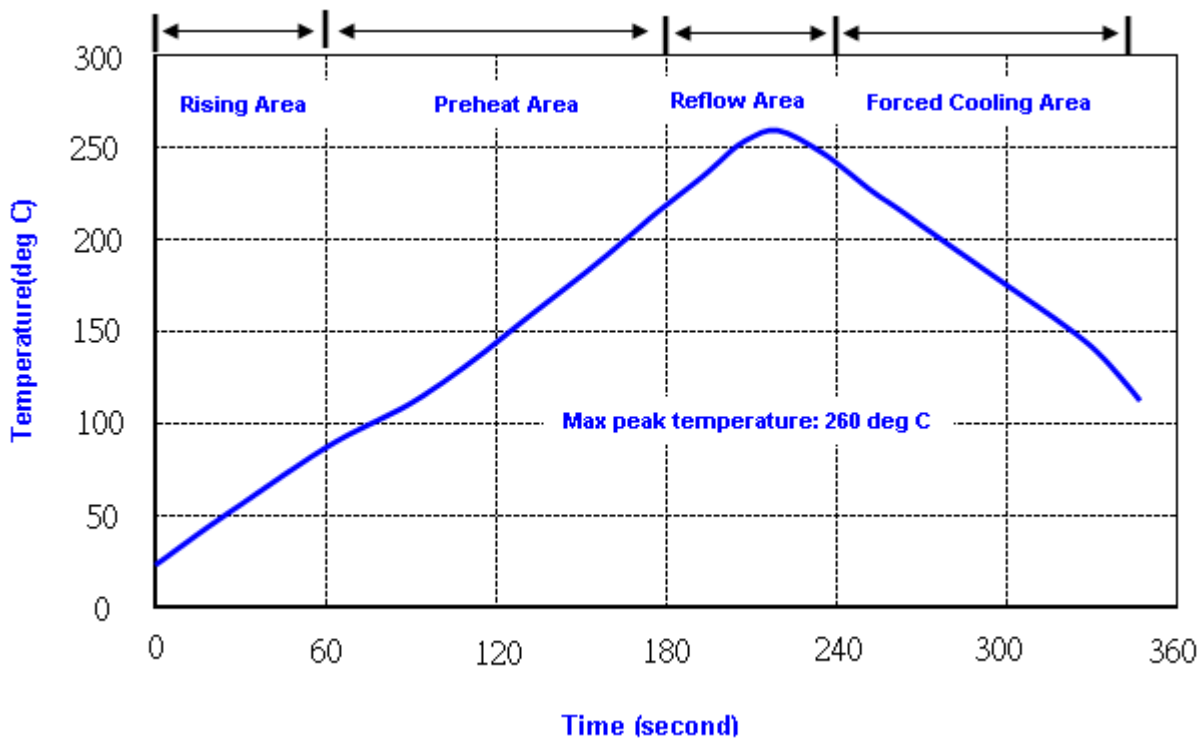

Note: 1. Max peak temperature: 260 +/- 5 deg C; Time: 10 +/- 2 sec
2. Temperature: 217 +/- 5 deg C; Time: 90~100 sec

Reliability Specifications

Test name	Test process / method	Reference standard
Mechanical characteristics		
resistance to Soldering heat (IR reflow)	Temp./ Duration : 265°C /10sec ×2 times Total time : 4min.(IR-reflow)	EIAJED-4701 -300(301)M(II)
Vibration	Total peak amplitude : 1.5mm Vibration frequency : 10 to 2000 Hz Sweep period : 20 minute Vibration directions : 3 mutually perpendicular Duration : 2 hr / direc.	MIL-STD 202G method 204
Mechanical Shock	directions : 3 impacts per axis Acceleration : 3000g's, +20/-0 % Duration : 0.3 ms (total 18 shocks) Waveform : Half-sine	MIL-STD 202G method 213
Solderability	Solder Temperature:265±5°C Duration time: 5±0.5 seconds.	J-STD-002
Environmental characteristics		
Thermal Shock	Heat cycle conditions -40 °C (30min) ←→ 85 °C (30min) * cycle time : 10 times	MIL-STD 883G method 1010.8
Humidity test	Temperature : 85 ± 2 °C Relative humidity : 85% Duration : 96 hours	MIL-STD 202G method 103
Dry heat (Aging test)	Temperature : 125 ± 2 °C Duration : 168 hours	MIL-STD 202G method 108A
Cold resistance (Low Temp Storage)	Temperature : -40 ± 2 °C Duration : 96 hours	IEC 60068-2-1