

PAGE 1/3	ISSUE 25-09-17A	SERIES NEX10	PART NUMBER R180301007
----------	-----------------	--------------	------------------------

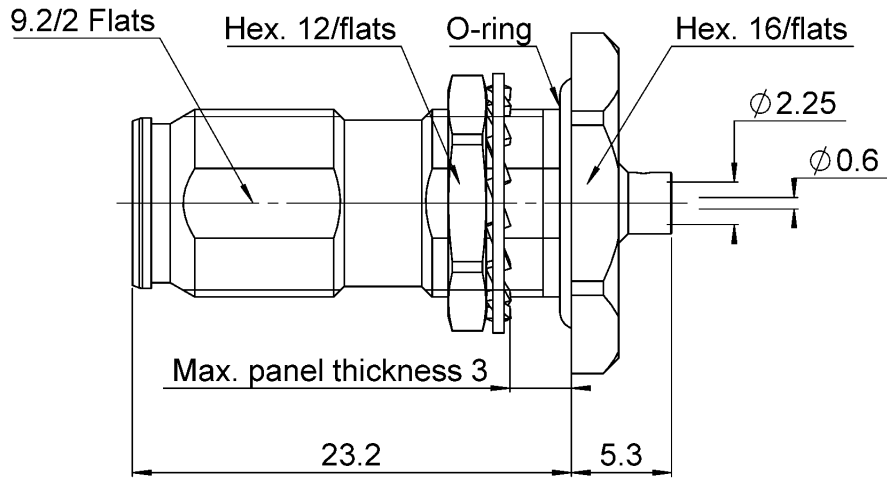

**PANEL CUT OUT**

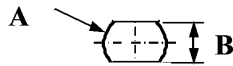

	mm	
	Maxi	mini
A	10.1	10
B	9.3	9.2

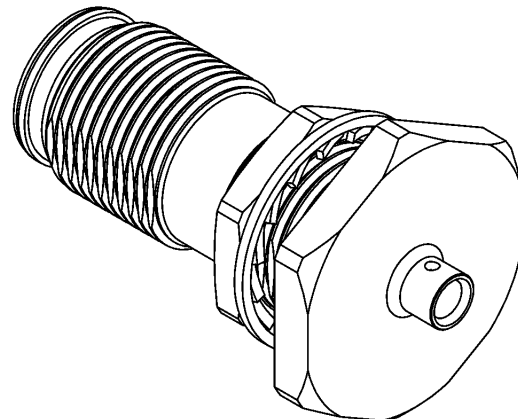
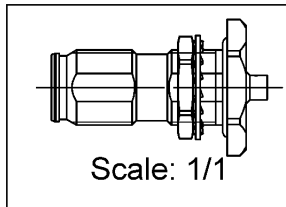

All dimensions are in mm.

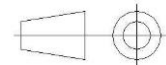

COMPONENTS	MATERIALS	PLATING (µm)
Body	<b>BRASS.</b>	<b>BBR</b>
Center contact	<b>BERYLLIUM COPPER</b>	<b>SILVER</b>
Outer contact		
Insulator	<b>PTFE</b>	
Gasket	<b>SILICONE RUBBER</b>	
Others parts	<b>BRASS/BRONZE</b>	<b>BBR</b>
-	-	-
-	-	-

PAGE 2/3	ISSUE 25-09-17A	SERIES NEX10	PART NUMBER R180301007
----------	-----------------	--------------	------------------------

### PACKAGING

Standard	Unit	Other
50	Contact us	Contact us

### ELECTRICAL CHARACTERISTICS

Impedance	50	Ω
Frequency	0-20	GHz
VSWR	1.02 + 0.0200	x F(GHz) Maxi
Insertion loss	0.05	√F(GHz) dB Maxi
RF leakage	- (NA)	- F(GHz) dB Maxi
Voltage rating	500	Veff Maxi
Dielectric withstanding voltage	1500	Veff mini
Insulation resistance	5000	MΩ mini

### MECHANICAL CHARACTERISTICS

Center contact retention		
Axial force – Mating End	NA	N mini
Axial force – Opposite end	NA	N mini
Torque	NA	N.cm mini
Recommended torque		
Mating	NA	N.cm
Panel nut	250	N.cm
Clamp nut	NA	N.cm
A/F clamp nut	0.0000	mm
Mating life	100	Cycles mini
Weight	14.5800	g

### ENVIRONMENTAL

Operating temperature	-55~+125	°C
Hermetic seal	NA	Atm.cm3/s
Panel leakage	IP67	

### SPECIFICATION

### CABLE ASSEMBLY

Stripping	a	b	c	d	e	f
mm	4	0	0	0	0	0

Assembly instruction: See page 3

Recommended cable(s)

**BELN 1671A**  
**RG 405**

-

Characteristics indicated on this data sheet are those that can be achieved with the highest performance cable. Intrinsic limitations of the cable may diminish the performance of the assembly

Cable retention

- pull off	200	N mini
- torque	NA	N.cm

### TOOLING

Part Number	Description	Hexagon
.	.	.

### OTHER CHARACTERISTICS

**Interface: IP68(1m,24h) mated condition**  
**Intermodulation: <=-123dBm, 2x20W**

PAGE 3/3	ISSUE 25-09-17A	SERIES NEX10	PART NUMBER R180301007
----------	-----------------	--------------	------------------------

**COMPONENTS**

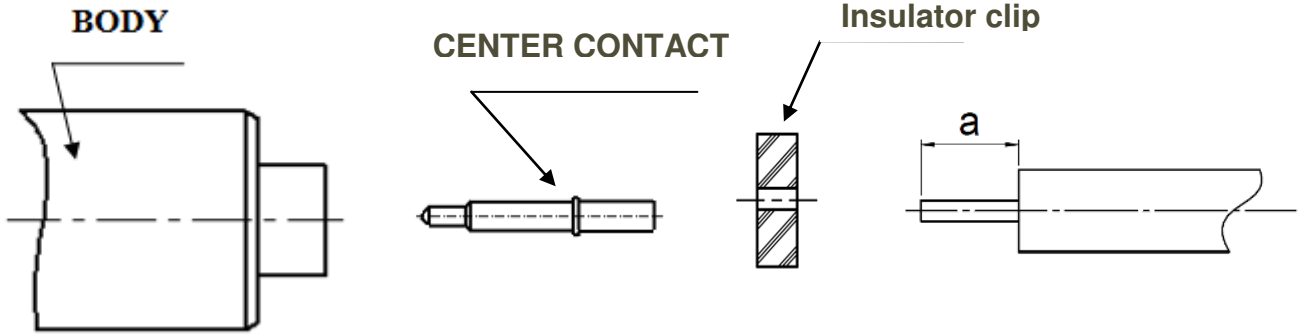

**1**

- Strip the cable with the cable stripping tool.
- Clean the cable



**2**

- Insert insulator clip on the cable
- Insert center contact until the insulator clip.
- Solder center contact

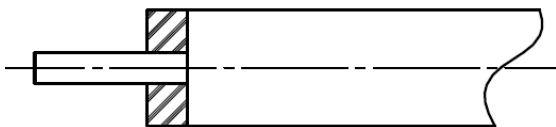

**3**

- Introduce the cable into the body until contact with the body shoulder.
- Place the sub-assembly on assembly jig
- Solder body on the cable.
- Let assembly cool down before removing it from the jig.

