

REVISIONS					
P	LTR	DESCRIPTION	DATE	DWN	APVD
F2	REVISED PER ECO-16-004000		28SEP2016	NK	MZ
G	REVISED PER ECO-17-011042		01AUG2017	RS	MZ

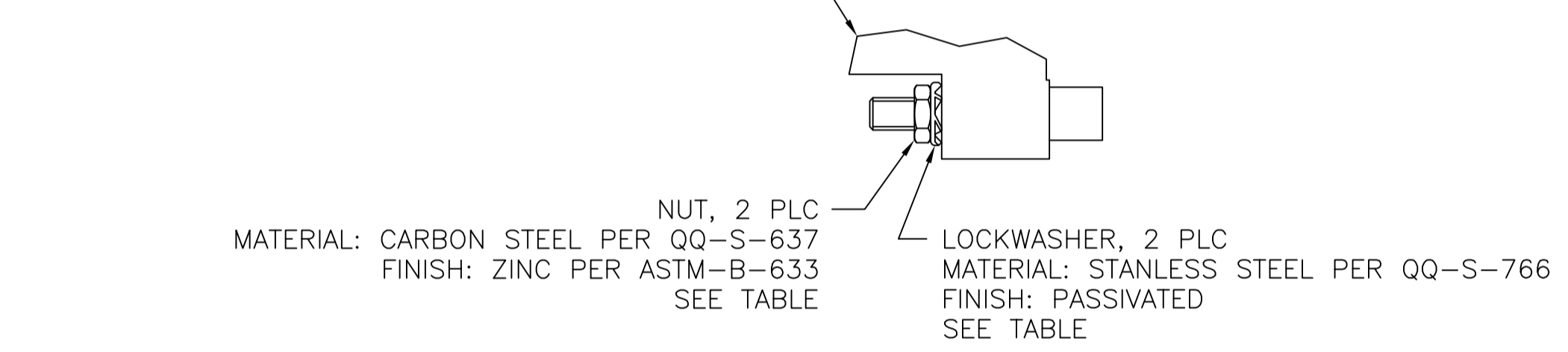
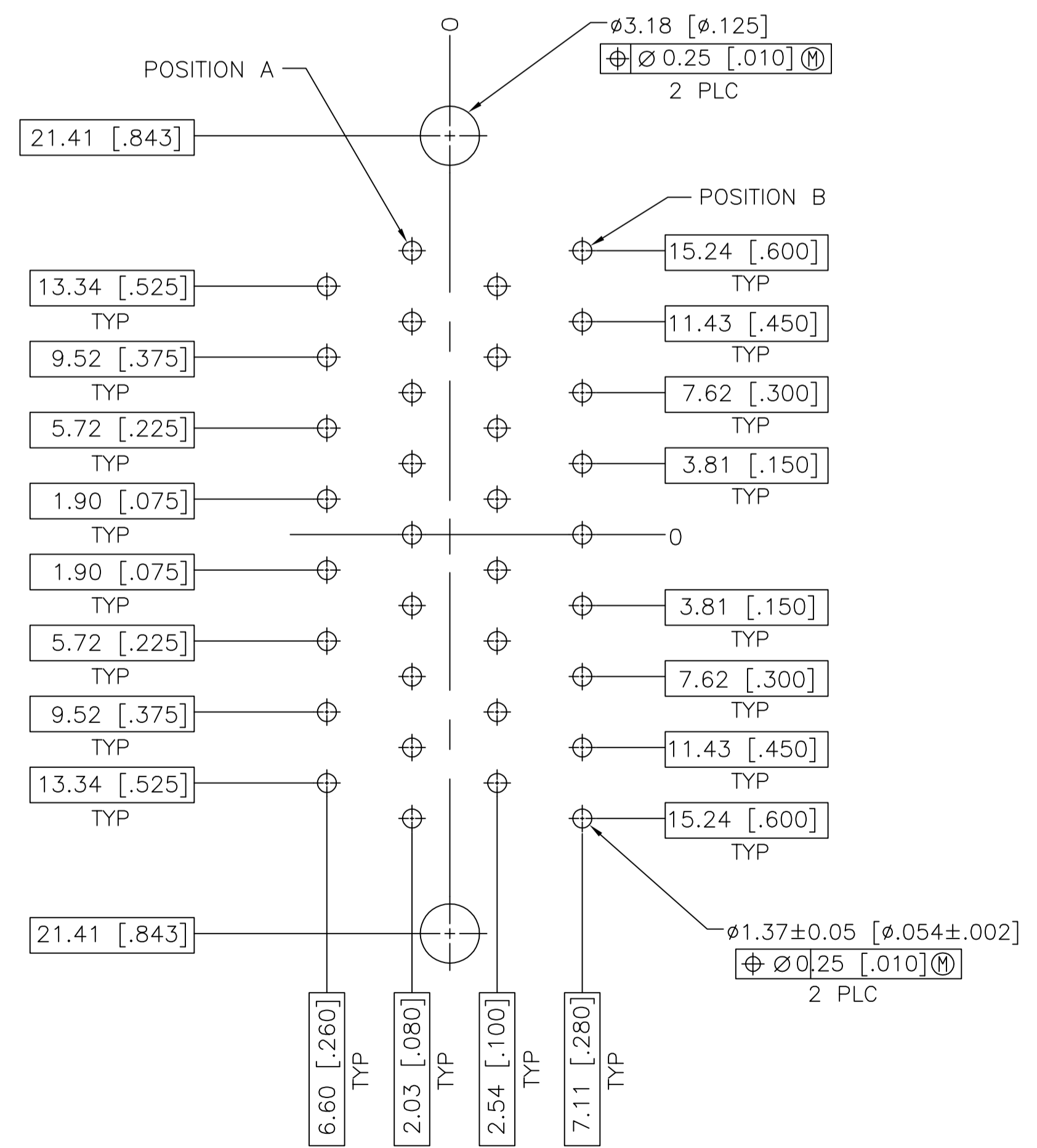
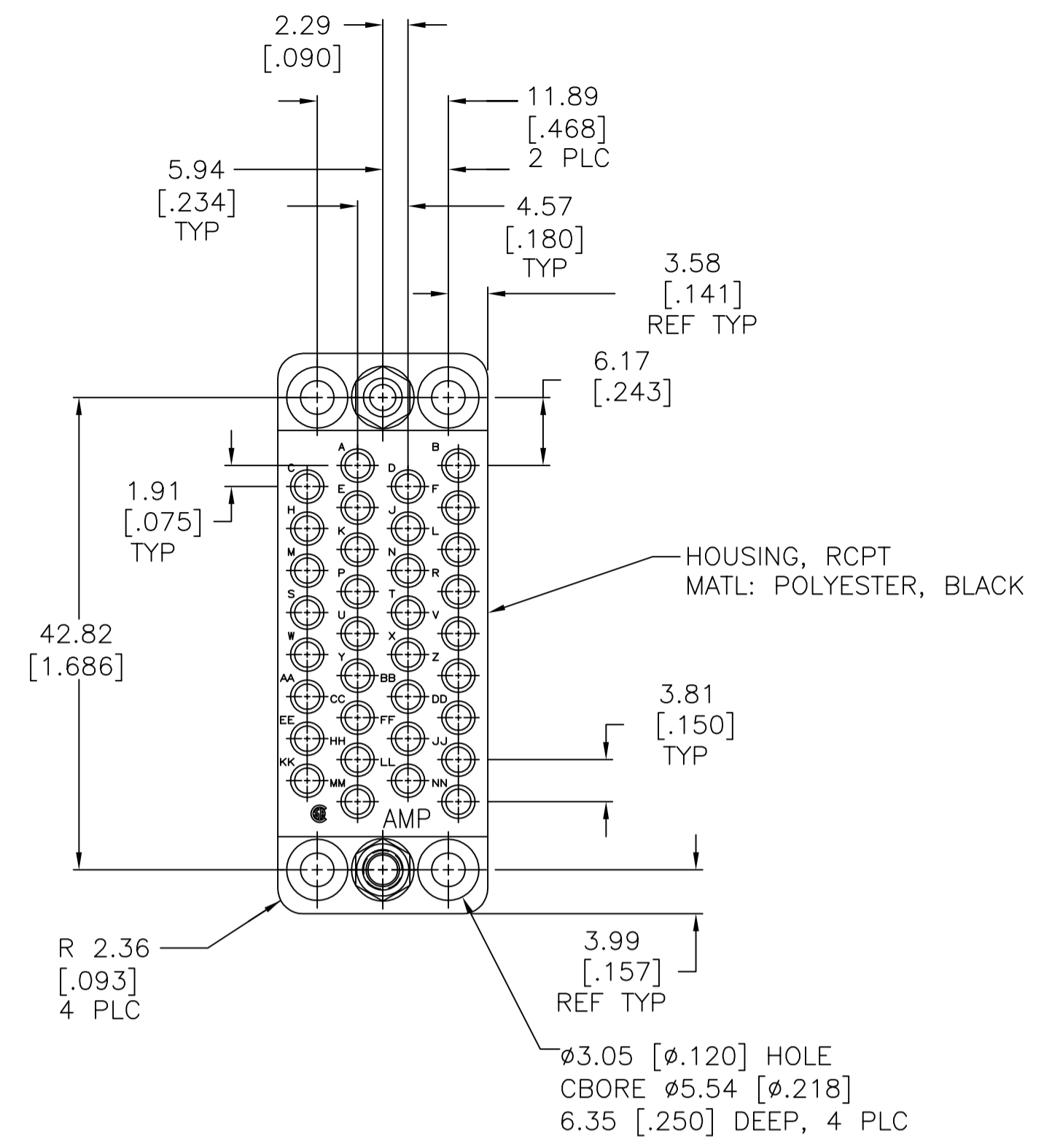
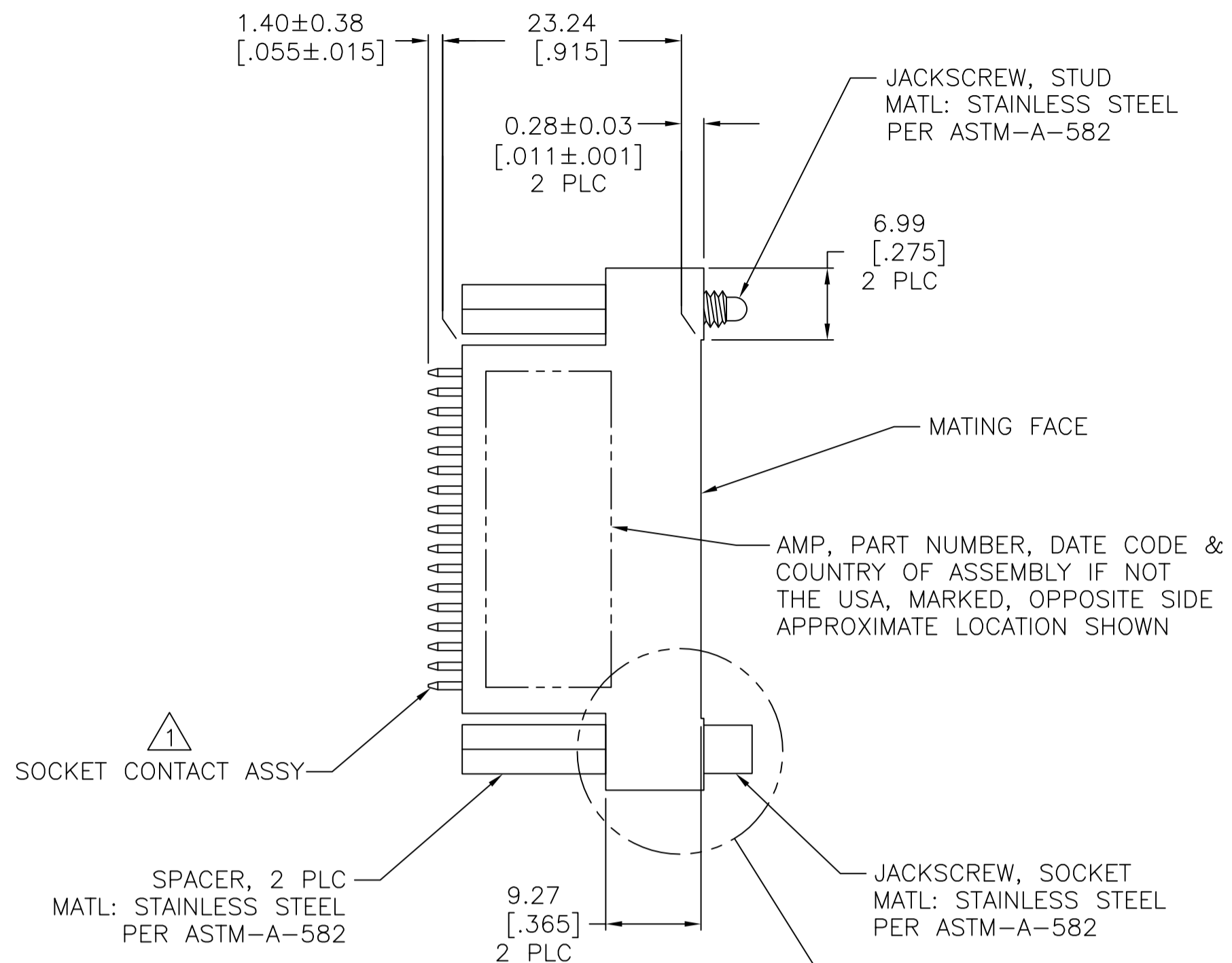
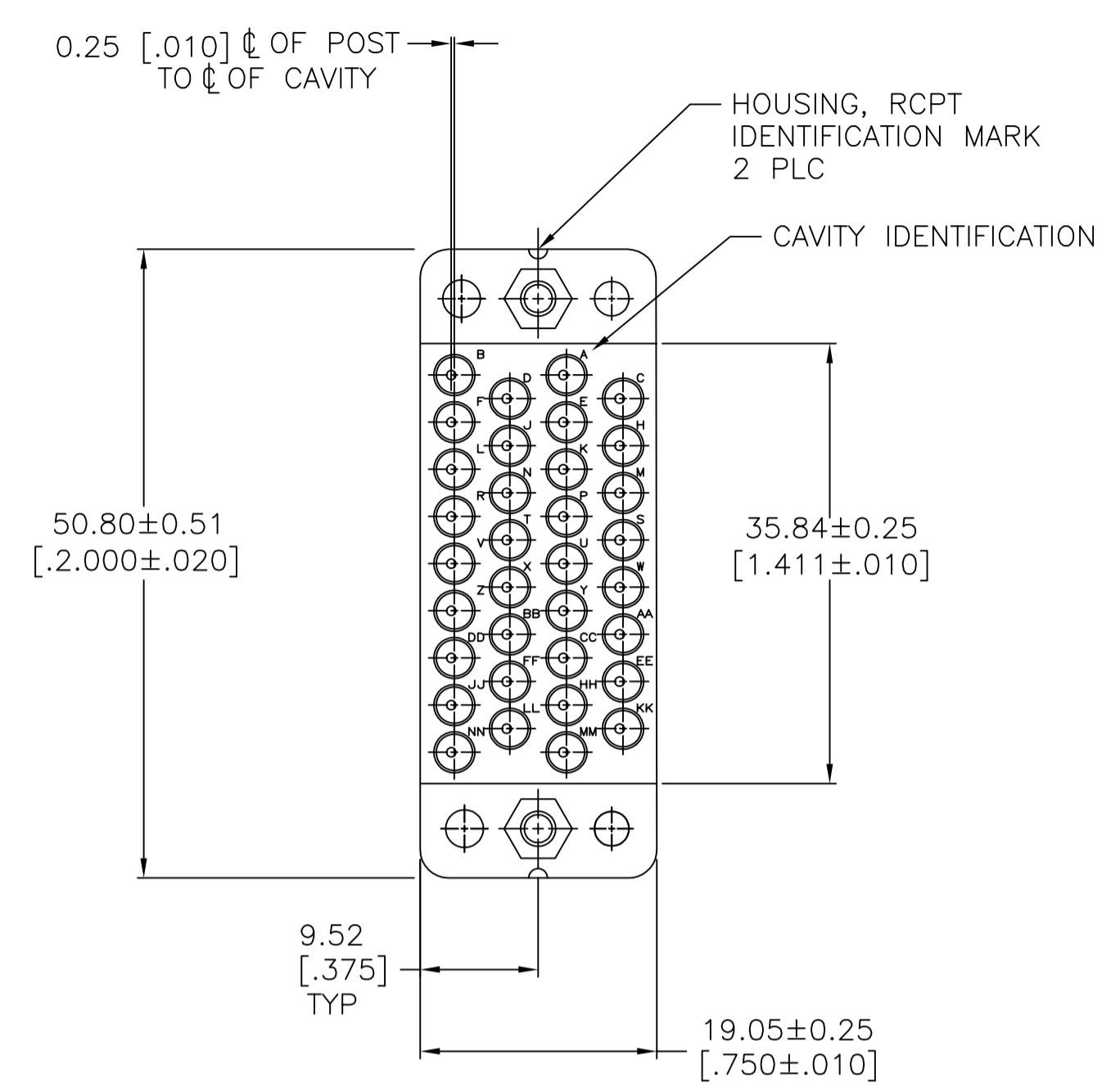

- 1 SOCKET CONTACT ASSEMBLY  
BODY-MATERIAL: BRASS PER MIL-C-50  
FINISH: 0.76um [.000030] MIN GOLD PER MIL-G-45204 FOR A LENGTH OF 5.08 [.200] MIN FROM MATING END, 2.54um [.000100] MIN TIN-LEAD PER MIL-T-10727 FOR A LENGTH OF 6.35 [.250] MIN FROM OPPOSITE END, BOTH OVER 1.27um [.000050] MIN NICKEL PER QQ-N-290.  
SPRING-MATERIAL: STAINLESS STEEL PER QQ-S-766.  
POST-MATERIAL: BRASS PER ASTM-B-134  
FINISH: 2.54um [.000100] MIN TIN-LEAD PER MIL-T-10727 OVER 1.27um [.000050] MIN NICKEL PER QQ-N-290.
- 2 SOCKET CONTACT ASSEMBLY IS SELECTIVELY LOADED AT CIRCUITS A,B,C,D,E,F,H,J,K,P,R,S,T,U,V,W,X,Y,AND AA.
- 3 SOCKET CONTACT ASSEMBLY IS SELECTIVELY LOADED AT CIRCUITS A,B,C,D,E,F,H,J,K,L,N,P,R,S,T,U,V,W,X,Y,AA,BB,AND NN.
- 4 SOCKET CONTACT ASSEMBLY  
BODY-MATERIAL: BRASS PER MIL-C-50  
FINISH: 0.76um [.000030] MIN GOLD PER MIL-G-45204 FOR A LENGTH OF 5.08 [.200] MIN FROM MATING END, 2.54um [.000100] MIN TIN PER MIL-T-10727 FOR A LENGTH OF 6.35 [.250] MIN FROM OPPOSITE END, BOTH OVER 1.27um [.000050] MIN NICKEL PER QQ-N-290.  
SPRING-MATERIAL: STAINLESS STEEL PER QQ-S-766.  
POST-MATERIAL: BRASS PER ASTM-B-134  
FINISH: 2.54um [.000100] MIN TIN PER MIL-T-10727 OVER 1.27um [.000050] MIN NICKEL PER QQ-N-290.
- 5 OBSOLETE PARTS: OBSOLETE CIS STREAMLINING PER D.RENAUD/D.SINISI

REV	DESCRIPTION	REV	DESCRIPTION	REV	DESCRIPTION
5	OBSOLETE	4	NUTS AND LOCKWASHERS	3	1-213809-0
5	OBSOLETE	4	SPACERS	3	213809-9
5	OBSOLETE	4	SPACERS	2	213809-8
		4	SPACERS		213809-7
5	OBSOLETE	1	NUTS AND LOCKWASHERS	3	213809-4
5	OBSOLETE	1	SPACERS	3	213809-3
5	SUPERSEDED	1	SPACERS	2	213809-2
		1	SPACERS		213809-1

RECOMMENDED PC BOARD LAYOUT  
SCALE 4:1

THIS DRAWING IS A CONTROLLED DOCUMENT.

DIMENSIONS: mm [INCHES]	TOLERANCES UNLESS OTHERWISE SPECIFIED:	DIN D. BROCKWAY 08-16-94	TE Connectivity
0 PLC ± -	1 PLC ± -	CHK R. STONE 08-25-94	APVD
2 PLC ± 0.13 [.005]	3 PLC ± -	PRODUCT SPEC	NAME
4 PLC ± -	ANGLES ± -	APPLICATION SPEC	SIZE CAGE CODE DRAWING NO
MATERIAL SEE CALLOUTS	FINISH SEE CALLOUTS	WEIGHT	A1 00779 ©=213809
CUSTOMER DRAWING		SCALE 2:1	SHEET 1 OF 1 REV G