



DLP-FR256
LEAD FREE

FERROELECTRIC MEMORY-BASED MICROCONTROLLER MODULE

The DLP-FR256 combines the same USB interface used in the DLP-USB245R module (FTDI FT245R FIFO) with a Texas Instruments microcontroller with 256K of FRAM to form a rapid development tool. The MSP430FR5994 microcontroller is preprogrammed with simple firmware that demonstrates the on-board white noise generator and analog interface, and the DLP-FR256 can be reprogrammed with user firmware via four pins using an MSP-EXP430FR5994 Launchpad (purchased separately).

FEATURES:

- The DLP-FR256 module utilizes a Texas Instruments 16-bit RISC architecture microcontroller with 256K bytes of FRAM, 8K bytes of SRAM and a multi-channel, 12-bit A/D converter:
 - Up to 16MHz operation
 - Ultra-low power FRAM operates as unified memory and is configurable as code, data or storage memory.
 - FRAM fast writes at 125nS per word (64KB in 4mS).
 - FRAM has virtually unlimited write endurance (10^{15} cycles).
 - FRAM is radiation resistant and nonmagnetic.
- The DLP-FR256 has 27 I/O lines available for interfacing to user electronics via a compact, 40-pin standard DIP footprint (two are configured with an onboard analog input interface for measuring voltage up to $\pm 20V$).
- Send/receive data over a full-speed USB 1.1 interface to a host computer at up to 1MByte per second.
- Required 5V power supply can be taken directly from the USB port or supplied by user electronics.
- The FRAM memory can be easily erased and reprogrammed utilizing a user-supplied compatible programmer.
- No in-depth knowledge of USB is required as all USB protocols are handled automatically by the on-board FT245R and its support circuitry:
 - Royalty-free device drivers eliminate the need for USB driver development in most cases.

- USB bulk or isochronous data-transfer modes
- USB 1.1 compatible
- USB VID, PID, serial number and product-description strings are stored in on-board EEPROM memory.

APPLICATION AREAS:

- Prototype Development
- USB ISDN and ADSL Modems
- USB Interface for Digital Cameras
- USB Interface for MP3 Players
- High-Speed USB Instrumentation
- USB Smart-Card Readers
- Set Top Box (STB) PC-USB Interface
- USB Hardware Modems
- USB Wireless Modems
- USB Bar Code Readers

1.0 GENERAL DESCRIPTION

The DLP-FR256 provides a cost-effective, microcontroller-based method of interfacing an electronic peripheral to a host computer via USB.

To send data from the peripheral to the host computer, the microcontroller simply writes data into the FT245R on its 8-bit data bus. Commands and data sent from the host are transferred on the same shared bus.

By using FTDI's Virtual COM Port Drivers, the peripheral looks like a standard COM port to the application software. The USB drivers are available for download from DLP Design's website at www.dlpdesign.com or from FTDI's website at www.ftdichip.com.

2.0 DRIVER SOFTWARE

FTDI's VCP (Virtual COM Port) driver-executable files are provided royalty free on the condition that they are used only with designs incorporating an FTDI device (i.e. the FT245R on the DLP-FR256). The latest versions of the drivers can be downloaded from www.dlpdesign.com or www.ftdichip.com.

The VCP driver download file is a combined set of drivers for all current versions of Windows. Unzip the file to a folder on your PC. (The drivers can coexist in the same folder since the INF files determine which set of drivers to load for each operating system version.) Once loaded, the VCP drivers allow the application software running on your host PC to communicate with the DLP-FR256 as though it were connected to a COM (RS-232) port.

In addition to VCP drivers, FTDI's D2XX direct drivers offer an alternative solution to allow application software to interface with the DLP-FR256 using a DLL instead of a Virtual COM Port. The architecture of the D2XX drivers consists of a Windows WDM driver that communicates with the device via the Windows USB stack and a DLL that interfaces the application software (written in VC++, C++ Builder, Delphi, VB, etc.) to the WDM driver.

The D2XX direct drivers add support for simultaneous access and control of multiple FT245R devices. The Extended Open function (FT_OpenEx) allows the device to be opened by either its product description or serial number, both of which can be programmed to be unique. The List Devices function (FT_ListDevices) allows the application software to determine which devices are currently available for use, again by either product description or by serial number.

Download FTDI Application Notes AN232-03, AN232-05, AN232-06 and AN232-07 for detailed instructions on how to install and remove the drivers.

3.0 EEPROM WRITE UTILITY

The DLP-FR256 has the option of accepting manufacturer-specific information that is written into on-board EEPROM memory. Parameters that can be programmed include the VID and PID identifiers, the manufacturer's product string or a serial number.

MPROG is an EEPROM serializer from FTDI for the FT245R device. MPROG is based on the D2XX drivers, and it will work on all current versions of Windows.

You must install the CDM drivers in order to run this application. (Refer to the MPROG User's Guide for details on the program's use.)

4.0 QUICK-START GUIDE

This guide requires the use of a Windows PC that is equipped with a USB port.

1. Download the WHQL-certified CDM device drivers from either **www.dlpdesign.com** or **www.ftdichip.com**. Unzip the drivers into a folder on the hard drive.

Note: The DLP-FR256 can be configured to receive its operating power from the USB port or from user electronics. Pins 19 and 20 allow for this configuration. (Refer to the Pinout Description in the next section for details on the DLP-FR256 electrical interface.)

****The board will not operate until a power source has been connected.****

2. Connect the DLP-FR256 board to the PC via a standard A-B, 6-foot USB cable. This action initiates loading of the USB drivers. When prompted, select the folder where the CDM device drivers were stored in Step 1. Windows will then complete installation of the device drivers for the DLP-FR256 board. (The next time the DLP-FR256 board is attached, the host PC will immediately load the correct drivers without any prompting.) Reboot the PC if prompted to do so.

The DLP-FR256 is shipped with default VID, PID, etc. values programmed into the EEPROM memory. You only need to run MPROG if you want to change the default values.

At this point, the DLP-FR256 is ready for use. Note that the DLP-FR256 will appear non-responsive if data sent from the host PC is not read from the FT245R device by the MSP430FR5994 microcontroller. The example firmware with which the DLP-FR256 comes preloaded will read data sent by the host by default. Custom user firmware should also follow this protocol.

TABLE 1: DLP-FR256 PINOUT DESCRIPTION

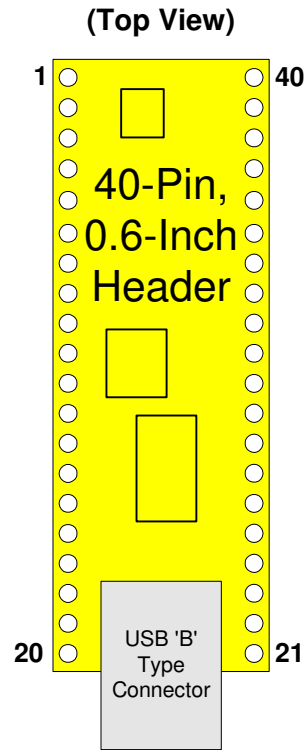

PIN #	DESCRIPTION
1	GROUND
2	P2.4/A7
3	P2.3/A6
4	GROUND
5	P1.2/A2
6	P1.0/A0
7	P1.1/A1
8	GROUND
9	P1.3/A3
10	P1.4/A4
11	P1.5/A5
12	PJ.1
13	PJ.3
14	PJ.2
15	PJ.0
16	P2.5
17	GROUND
18	SWVCC (Out) - Switched 5V power from the host PC. This output becomes active once enumeration is complete.
19	EXTVCC (In) - Use for applying main power (4.4-5.25 volts) to the module; connect to PORTVCC if the module is to be powered by the USB port (typical configuration).

20	PORTVCC (Out) - USB port power. Connect to EXTVCC if the module is to be powered by the USB port (typical configuration). 500mA is the maximum current available to the DLP-FR256 and target electronics if the USB device is configured for high power.
21	GROUND
22	3V3 (Out) - Power from the 3.3V regulator (active once enumeration is complete).
23	P2.6
24	P2.0
25	P2.1
26	P2.2
27	P3.4
28	P3.6
29	GROUND
30	P3.7
31	P1.6
32	GROUND
33	P1.7
34	P3.5
35	P3.1/A13
36	P3.0/A12
37	GROUND
38	ANA_IN- (In) – Negative analog differential input
39	ANA_IN+ (In) – Positive analog differential input
40	GROUND

5.0 PROGRAMMING / DEBUGGING

The MSP430FR5994 can be reprogrammed using a Texas Instruments MSP-EXP430FR5994 Launchpad. Before connecting the required three wires to the DLP-FR256, you must first remove three shorting headers from J101 (GND, SBWTCK and SBWTDIO) on the Launchpad.

J2 Spy-By-Wire

Pin 1 3V3 Power
Pin 2 Ground
Pin 3 SPWTCK
Pin 4 RST

J101 on the Launchpad

Connection not needed as the DLP-FR256 will take power from the USB host
GND Pin
SBWTCK
SBWTDIO

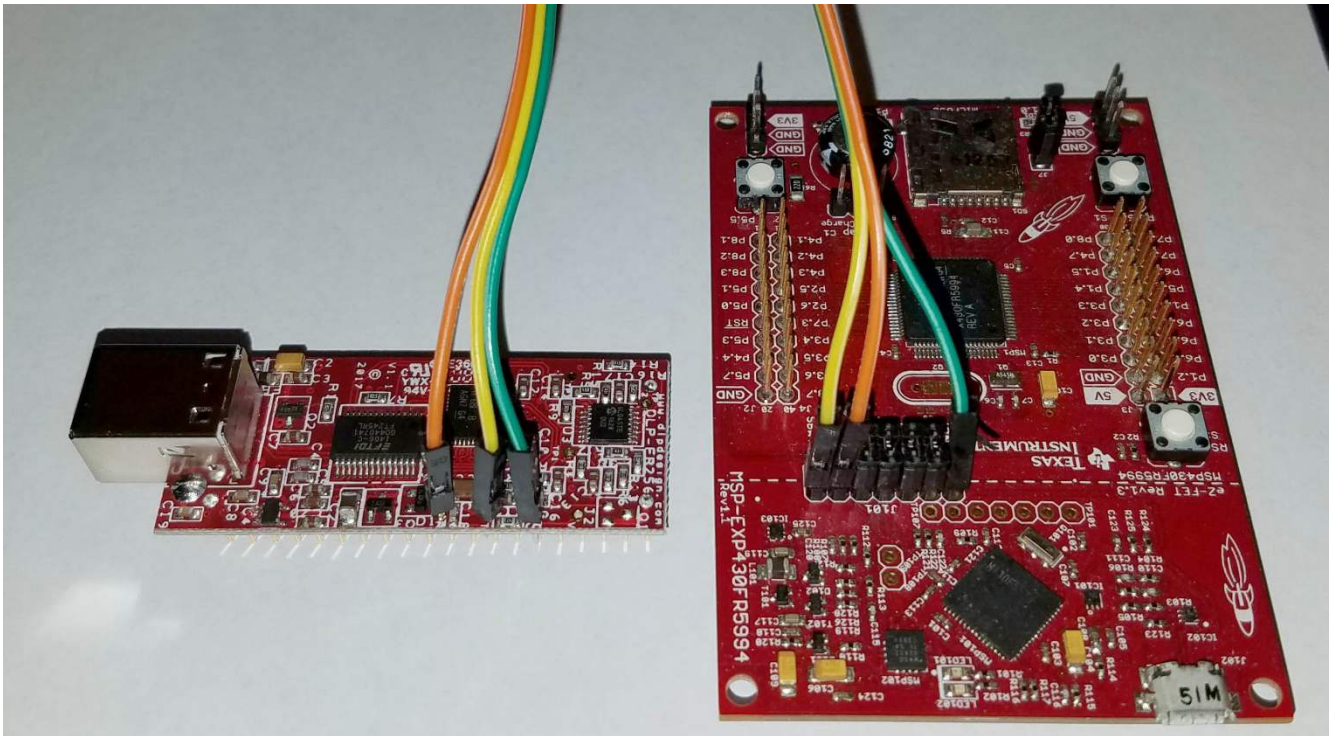

**6.0 PRELIMINARY MECHANICAL DRAWINGS - INCHES (MILLIMETERS)
UNLESS OTHERWISE NOTED**

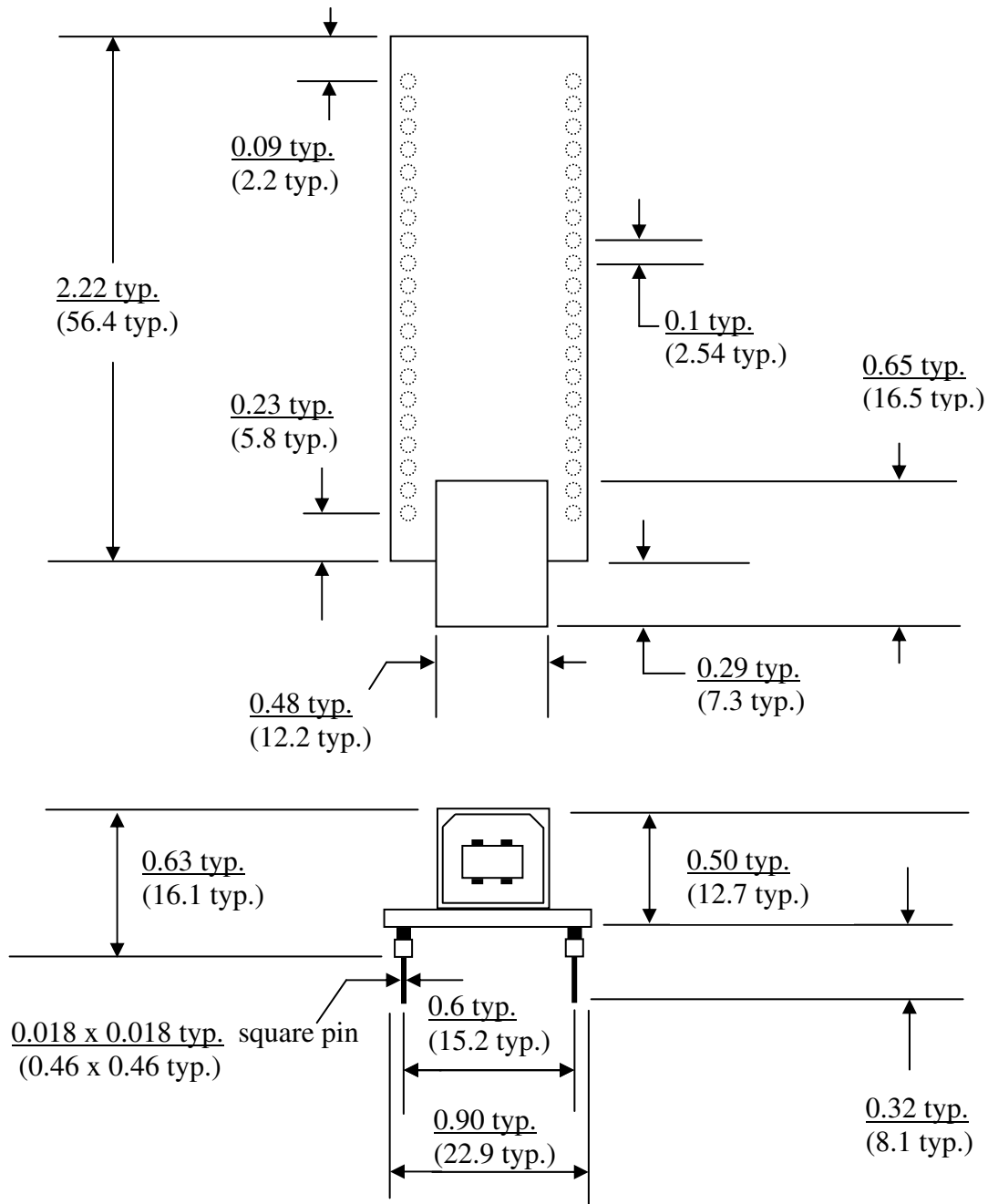

7.0 DISCLAIMER

Neither the whole nor any part of the information contained within or the product described in this datasheet may be adapted or reproduced in any material or electronic form without the prior written consent of the copyright holder.

This product and its documentation are supplied on an as-is basis, and no warranty as to their suitability for any particular purpose is either made or implied. DLP Design will not accept any claim for damages whatsoever arising as a result of the use or failure of this product. Your statutory rights are not affected.

This product or any variant of it is not intended for use in any medical appliance, device or system in which the failure of the product might reasonably be expected to result in personal injury.

This document provides preliminary information that may be subject to change without notice.

8.0 CONTACT INFORMATION

DLP Design, Inc.
1605 Roma Lane
Allen, TX 75013

Email: support@dlpdesign.com
Internet: <http://www.dlpdesign.com>

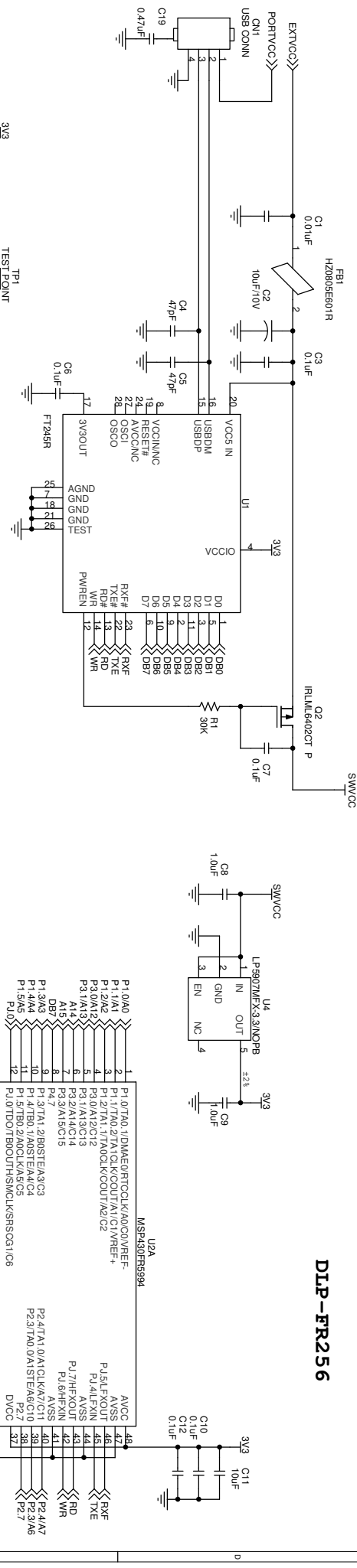

BIPOLAR ANALOG INPUT BUFFER

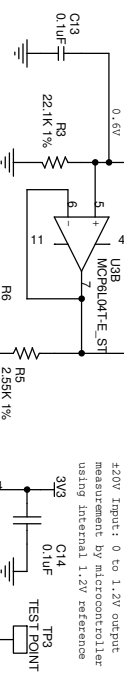

BOOST CONVERTER

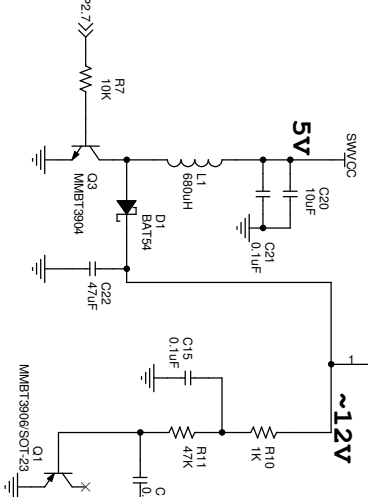

WHITE NOISE GENERATOR

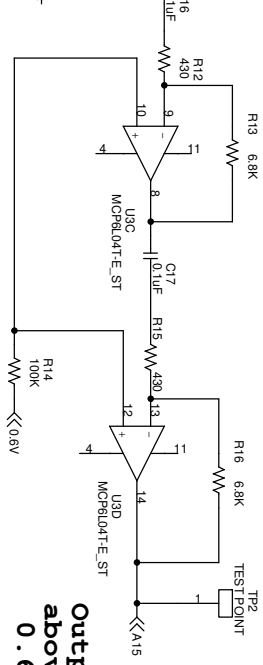

Output swings
above and below
0.6V

MSP430F5994 USA

P1.0/A0	P1.0/TD0.1/DMAE0/RTCLK/KAD0/CVREF-	48	AVCC
P1.1/A1	P1.1/TD0.2/TD1A1/CLK/COUTA1/C1VREF+	49	AVSS
P1.2/A2	P1.2/TD1.1/TD0/CLK/COUTA2/PA2/C2	46	AVSS
P1.3/A3	P1.3/DMA12/C12	45	P1.5/CLKOUT
P1.4/A4	P1.4/DMA12/C14	44	P1.4/F2N
P1.5/A5	P1.5/P1A15	43	P1.7/HF2N
A15	P3.3/A15/C15	42	P1.6/HF2N
DB7	P3.3/A15/C15	41	AVSS
P1.3/A3	P4.7	38	P2.4/TA1.0/CLKA7/C11
P1.4/A4	P1.3/TA1.2/BOOSTEA3/C3	39	P2.3/TA0.0/STEA6/C10
P1.5/A5	P1.4/TB0.1/TA0/CLKA4/C4	37	P2.2/TA0.0/STEA6/C10
P1.0/A0	P1.5/TB0.2/TA0/CLKA5/C5	36	DVSS
P1.1/A1	P1.0/TB0.0/TA0/CLKA0/C0	35	P4.6
P1.2/A2	P1.1/TD1/CLK/MCLK/SRSCG0/C7	34	P4.5
P1.3/A3	P1.2/TMSA/CLK/SRSCFF/C8	33	P4.4/TB0.5
P1.4/A4	P1.3/TK/SRCPUF/C9	32	P4.3/TB0.5
P1.5/A5	P4.0/A8	31	P4.2/TB0.5
DB8	P4.0/A8	30	P1.6/TB0.3/B0/SIM0/B0SUL/TA0
DB2	P4.2/A10	29	P3.6/TB0.5
DB3	P4.3/A11	28	P3.7/TB0.5
DB4	P2.5/TB0.0/ATXD/A1/SIM0	27	P3.8/TB0.5
P2.6	P2.6/TB0.1/ATXD/A1/SIM1	26	P3.5/TB0.4/COUT
P2.7	TEST/SWTK	25	P3.4/TB0.3/SMCLK
P2.8	TEST/SWTK	24	P2.7/TB0.2/SMCLK
P2.9	TEST/SWTK	23	P2.2/TB0.0/AND/A0/SIM0
P3.0	TEST/SWTK	22	P2.1/TB0.0/AND/A0/SIM1
P3.1	TEST/SWTK	21	P2.0/TB0.0/AND/A0/SIM0/TBCLK/KCLK
P3.2	TEST/SWTK	20	
P3.3	TEST/SWTK	19	
P3.4	TEST/SWTK	18	
P3.5	TEST/SWTK	17	
P3.6	TEST/SWTK	16	
P3.7	TEST/SWTK	15	
P3.8	TEST/SWTK	14	
P3.9	TEST/SWTK	13	
P4.0	TEST/SWTK	12	
P4.1	TEST/SWTK	11	
P4.2	TEST/SWTK	10	
P4.3	TEST/SWTK	9	
P4.4	TEST/SWTK	8	
P4.5	TEST/SWTK	7	
P4.6	TEST/SWTK	6	
P4.7	TEST/SWTK	5	
P4.8	TEST/SWTK	4	
P4.9	TEST/SWTK	3	
P5.0	TEST/SWTK	2	
P5.1	TEST/SWTK	1	

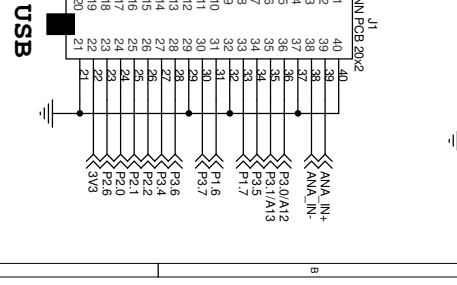

Title	Size	Document Number	Rev
<Title>	B	<Doc>	<Rev Code>

Date: Sunday, June 04, 2017 Sheet 1 of 1