

REVISIONS				
P	LTM	DESCRIPTION	DATE	APPV
G9		REVISED PER ECR-16-012572	04OCT2016	BW RS

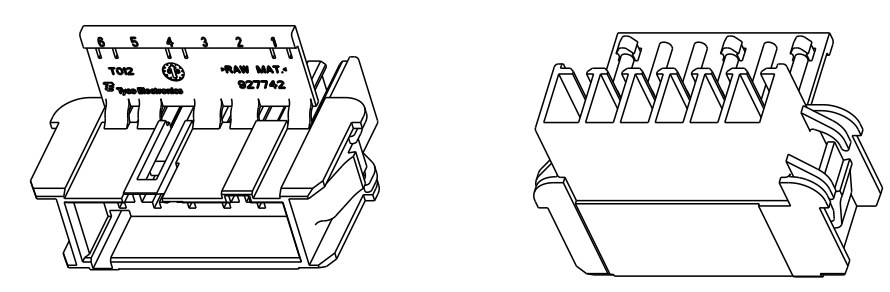
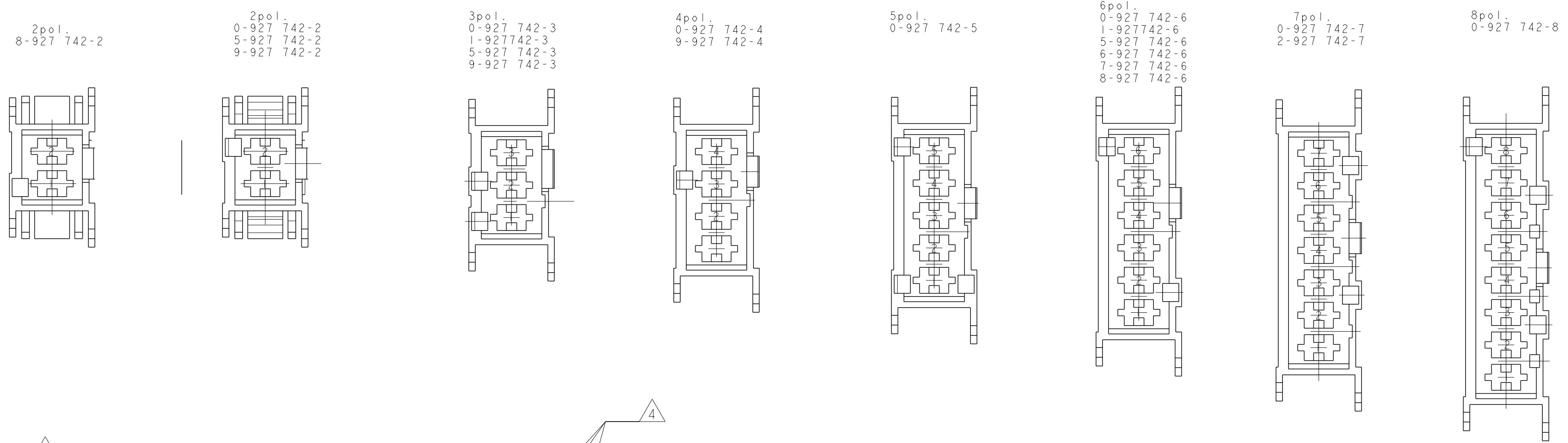

SCALE 1:1

1) TYPICAL CAVITY SUITABLE FOR:
 FASTIN-FASTON TAB CONTACTS 6.3 mm SRS:
 P/N: 60294, 0.3-0.8 mm2 WIRE RANGE
 160691, 0.3-0.8 mm2 WIRE RANGE
 AMPLIVAR CONTACTS:
 P/N: 141051, 0.1-0.5 mm2 WIRE RANGE
 142411, 0.3-1.6 mm2 WIRE RANGE
 MAX. INSULATION DIA. 2.8 mm,
 MAX. INSULATION CRIMP WIDTH 3.3 mm.

- 2) SEE TABLE FOR SUITABLE COUNTERPART.
- 3) CIRCUIT IDENTIFICATION No. ACCORDING TO DIN 1451.
- 4) POLARIZATION KEYS DIMENSIONS AND POSITIONS ARE ACCORDING TO "RAST 5" NORM
- 5) TE TRADEMARK "LOGO" AND TYCO ELECTRONICS "PART NUMBER" OPTIONAL POSITION.
- 6) PACKAGING ACCORDING TO TE SPEC. 107-20248.
- 7) PRODUCT ACCORDING TO IEC 60335-1 NORM.
- 8) NOT TOOLED YET.
- 9) SPECIAL VERSION WITH LARGER GAP "A"

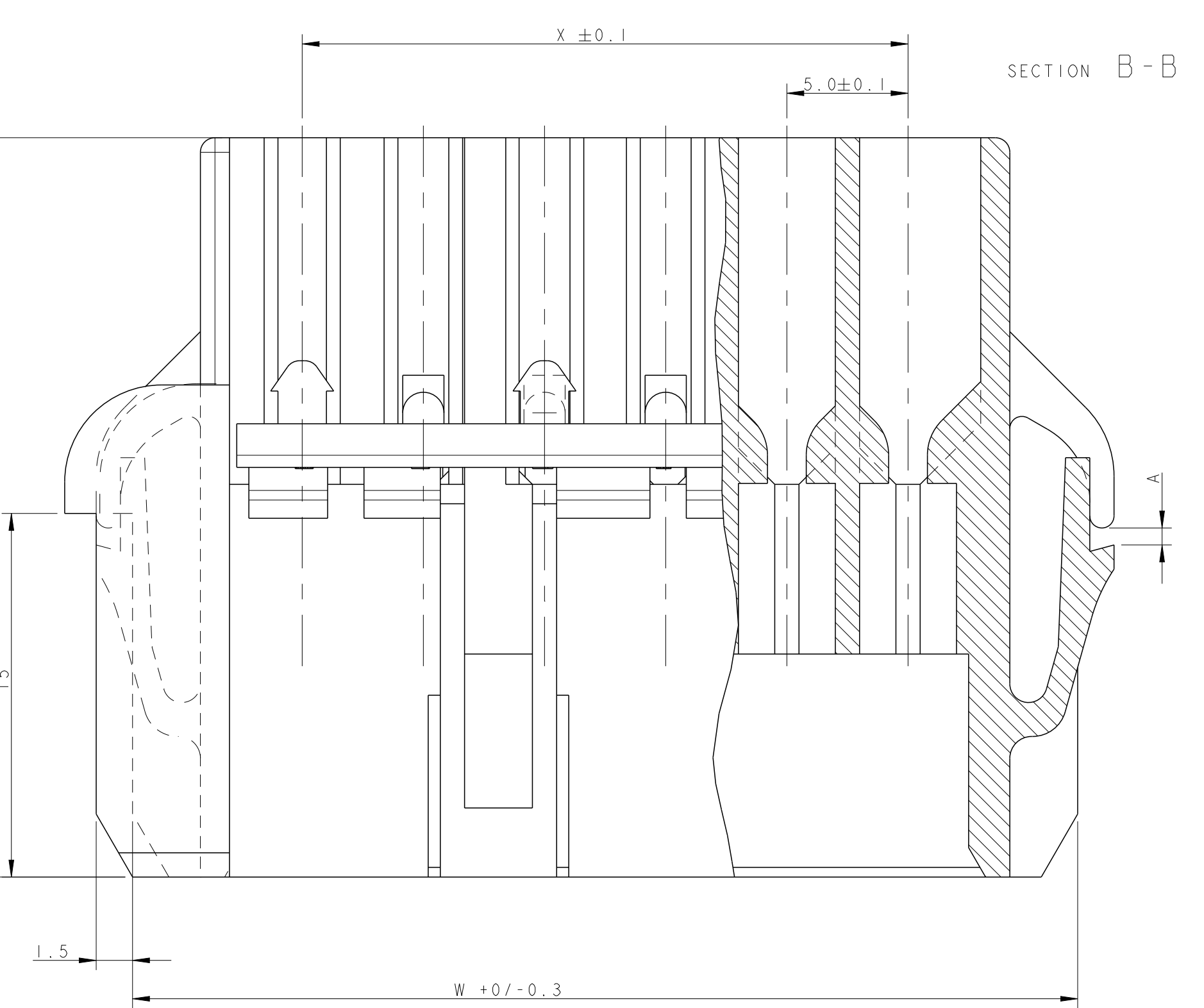
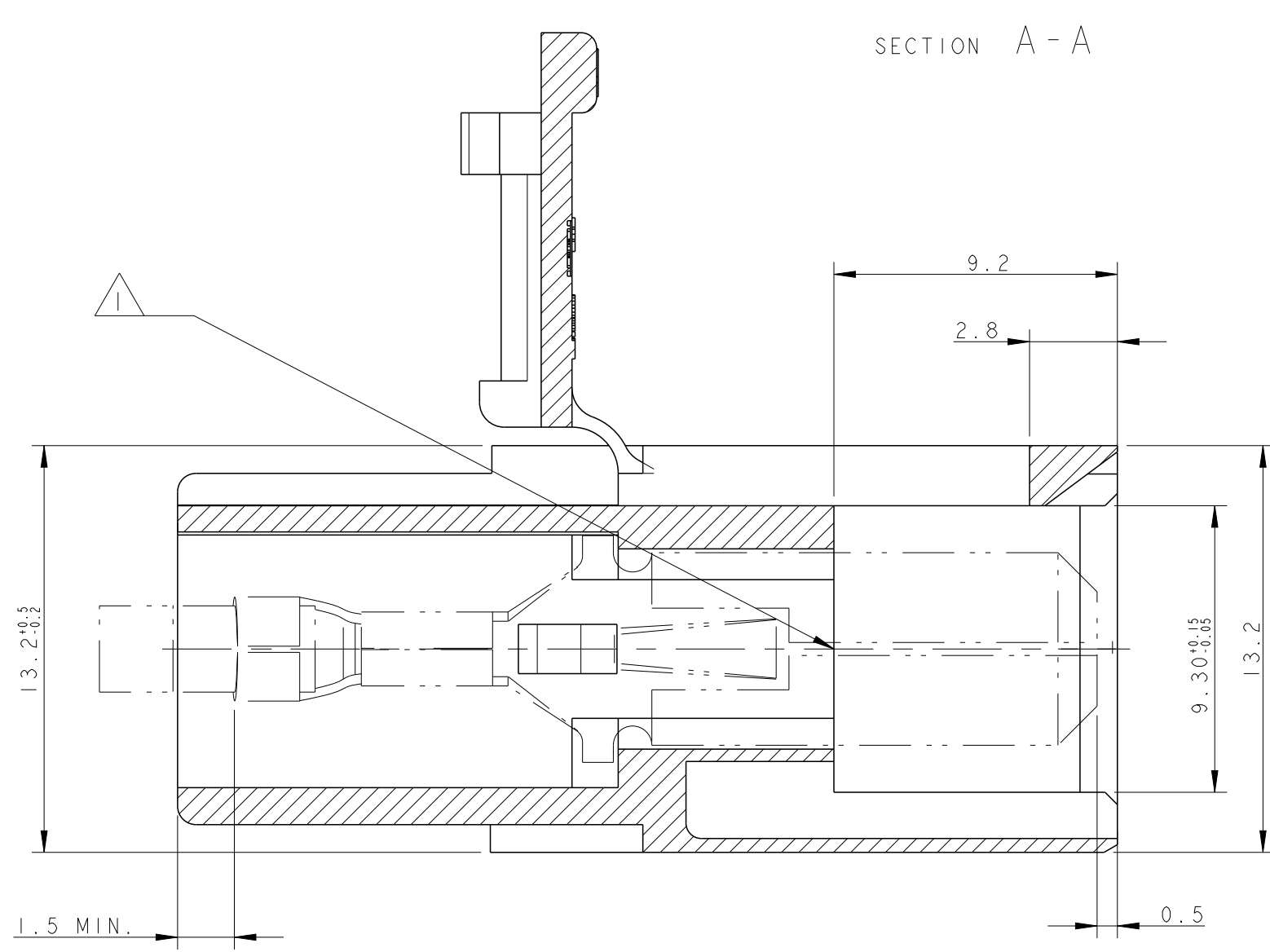
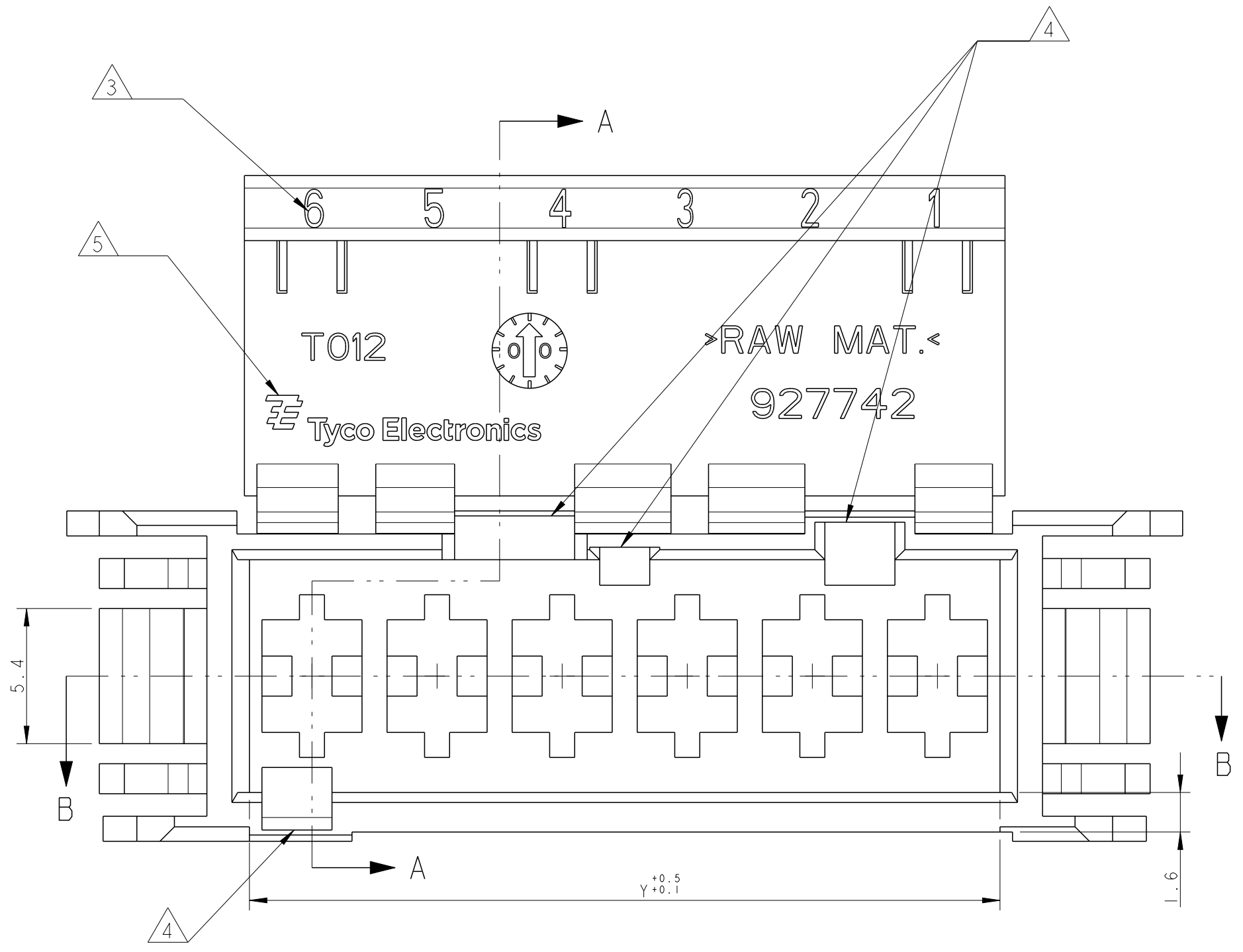

PANEL CUT DIMENSIONS SCALE 1:1

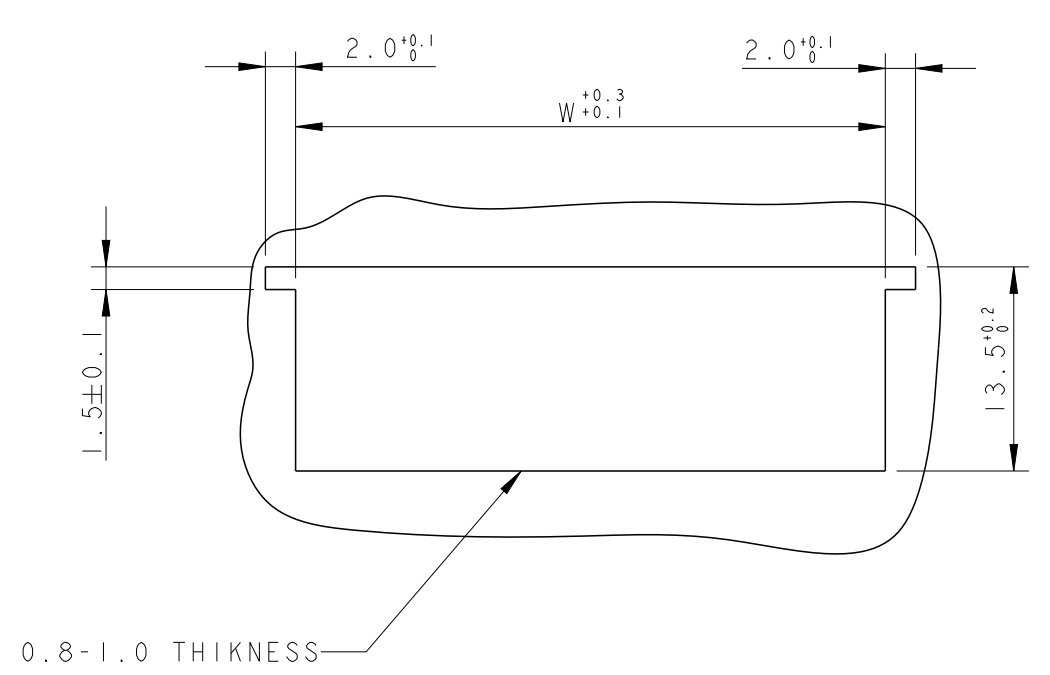

POS.	W	X	Y	PART-NO.	STANDARD TIMER	MATERIAL	COLOUR	REV.	NOTE
12	-	-	-	-	-	-	-	-	-
11	-	-	-	-	-	-	-	-	-
10	-	-	-	-	-	-	-	-	-
9	-	-	-	-	-	-	-	-	-
8	-	-	-	-	-	-	-	-	-
7	44	30	35	2-927 742-7	0-927 740-7	UL94V-2	black	-	-
7	44	30	35	0-927 742-7	0-927 740-7	UL94V-2	natur	-	-
6	39	25	30	8-927 742-6	0-927 740-6	UL94-V0	natur	-	1
6	39	25	30	7-927 742-6	0-927 740-6	UL94V-2	natur	-	1
6	39	25	30	6-927 742-6	0-927 740-6	UL94V-0	black	-	-
6	39	25	30	5-927 742-6	0-927 740-6	UL94V-0	natur	-	-
6	39	25	30	1-927742-6	927740-6	UL94-V2	natur	-	7 9
6	39	25	30	0-927 742-6	0-927 740-6	UL94V-2	natur	-	-
5	34	20	25	0-927 742-5	0-927 740-5	UL94V-2	natur	-	9
4	29	15	20	9-927 742-4	0-927 740-4	UL94V-2	natur	-	7
4	29	15	20	0-927 742-4	0-927 740-4	UL94V-2	natur	-	-
3	24	10	15	9-927 742-3	0-927 740-3	UL94V-2	natur	-	1
3	24	10	15	5-927 742-3	0-927 740-3	UL94V-0	natur	-	-
3	24	10	15	2-927 742-3	0-927 740-3	UL94V-2	grey	-	-
3	24	10	15	1-927742-3	927740-3	UL94V-2	natur	-	7 9
OBSELETE	3	24	10	0-927 742-3	0-927 740-3	UL94V-2	natur	-	-
2	19	5	10	9-927 742-2	4-927 740-2	UL94V-2	natur	-	1
2	19	5	10	8-927 742-2	-	UL94V-2	natur	-	1
2	19	5	10	5-927 742-2	4-927 740-2	UL94V-0	natur	-	-
2	19	5	10	0-927 742-2	4-927 740-2	UL94V-2	natur	-	9

THIS DRAWING IS A CONTROLLED DOCUMENT. DWN: YAALI Z2MAR2005
 CHK: G. TURCO
 APVD: -

TE Connectivity

NAME: 2-12 POS. FASTIN-FASTON CONNECTOR TAB HOUSING RAST 5, PANEL MOUNT VERSION

PRODUCT SPEC: -
 APPLICATION SPEC: -

SIZE: A100779C=927742
 CAGE CODE: -
 DRAWING NO: -

RESTRICTED TO: -

WEIGHT: -
 MATERIAL: SEE TABLE
 FINISH: SEE TABLE

CUSTOMER DRAWING

SCALE: 5:1 SHEET 1 OF 1 REV: G9