

molex[®] PRODUCT SPECIFICATION

LITE-TRAP CONN. BOTTOM ENTRY TYPE -1CKT, 2CKTS

1. SCOPE (적용범위)

This Product Specification covers the LITE-TRAP CONN. BOTTOM ENTRY -1CKT, 2CKTS
(이 Spec은 LITE TRAP CONN. BOTTOM ENTRY -1CKT, 2CKTS 에 대하여 규정한다)

2. PRODUCT DESCRIPTION (제품구성)

2.1 PRODUCT NAME AND SERIES NUMBER (제품명 & 제품번호)

Product Name (제품명칭)	Parts Number (제품번호)
LITE-TRAP CONN. BOTTOM ENTRY -1CKT (Embossed Packing)	104266-0110
LITE-TRAP CONN. BOTTOM ENTRY -2CKTS (Embossed Packing)	104266-0210

2.2 DIMENSIONS, MATERIALS, PLATINGS AND MARKINGS(치수, 재질, 도금 및 마킹)

See the appropriate Sales Drawings for information on dimensions, materials, platings, and markings. (관련도면 참조)

3. APPLICABLE DOCUMENTS AND SPECIFICATIONS

Sales drawing : SD-104266-001, SD-104266-002, SD-104266-003, SD-104266-004

Packing specification : PK-104266-001

4. RATINGS (정격)

ITEM (항목)		STANDARD (규격)	
Rated Voltage (Max.) 최대허용전압 (According to UL Test Condition)		320V [AC (rms 실효치)/DC]	
Rated Current Ampere (Max.) 최대허용전류 (According to UL Test Condition)	Solid Wire [refer to 8] [8항 참조]	AWG#24(0.2mm ²)	5.0A Max.
		AWG#22(0.3mm ²)	5.0A Max.
		AWG#20(0.5mm ²)	6.0A Max.
		AWG#18(0.8mm ²)	9.0A Max.
	Strand Wire [refer to 8] [8항 참조]	AWG#24(0.20mm ²)	5.0A Max.
		AWG#22(0.45mm ²)	5.0A Max.
		AWG#20(0.7mm ²)	6.0A Max.
Rated Voltage (Max.) 최대허용전압 (According to IEC 60838 Test Condition)		AC50V(DC120V)	
Rated Current Ampere (Max.) 최대허용전류 (According to IEC 60838 Test Condition)		3.0A MAX.	
Ambient Temp. Range (Operating and Non-operating) 사용온도 범위		-60°C ~ +130°C Include Terminal Temperature Rise 통전에 의한 온도상승 포함. (By UL Conditions)	
		-30°C ~ +65°C (By IEC 60838 Conditions) (The rated operating temperature)	

Outside Insulation Dia. 절연피복외경 : Φ 2.1 mm Max.

REVISION:	ECR/ECN INFORMATION:	TITLE:	SHEET No.
A1	EC No: KOR2016-0064 DATE: 2016 / 03 / 15	LITE-TRAP CONNECTOR. BOTTOM ENTRY TYPE 1CKT, 2CKTS	1 of 9
DOCUMENT NUMBER:	CREATED / REVISED BY:	CHECKED BY:	APPROVED BY:
PS-104266-001	JS.SHIN	SH.CHU	YSOO.KIM

molex[®] PRODUCT SPECIFICATION

5. PERFORMANCE(성능)

5-1. ELECTRICAL REQUIREMENTS(전기적 특성)

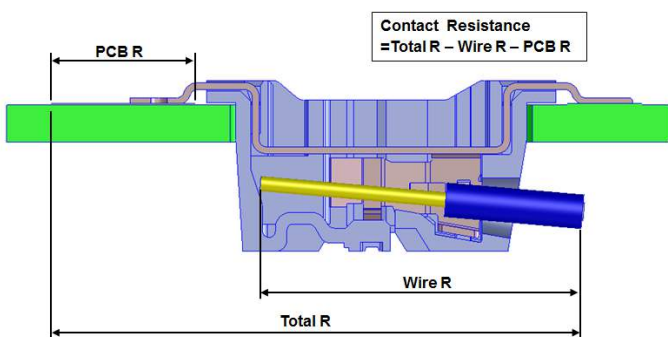
ITEM 항 목	TEST CONDITION 시험 조건	REQUIREMENT 규 격
1 Contact Resistance 접촉 저항	<p>Mate Connector & Wire : apply a maximum voltage of 20 mV and a current of 100mA. Wire and PCB resistance shall be removed from the measured value.</p>  <p>커넥터에 Wire를 결합하여, 20mV이하의 전압, 100mA이하의 전류를 인가한다. 저항 측정 값에서 전선 저항치는 제외한다</p>	10 milliohms MAXIMUM
2 Insulation Resistance 절연 저항	<p>Mate connector & Wire : apply a voltage of 500 VDC between adjacent terminals and between terminals to ground.</p> <p>커넥터에 Wire를 결합하여, 인접단자 간 그리고 단자와 그라운드간에 DC500V를 인가한다</p>	1,000 Mega ohms MINIMUM
3 Dielectric Withstanding Voltage 내 전압	<p>Mate Connector & Wire : apply a voltage of 1,640 VAC for 1 minute between adjacent terminals and between terminals to ground.</p> <p>커넥터에 Wire를 결합하여, 인접단자 간 그리고 단자와 그라운드간에 AC1,640V를 1분간 인가한다.</p>	No breakdown 이상 없을 것
4 Temperature Rise 온도 상승	<p>Mate connector & Wire : measure the temperature rise at the rated current. (by UL Test Condition)</p> <p>커넥터에 Wire를 결합하여, 정격 전류를 인가하여 온도 상승을 측정한다. (UL Test 조건)</p>	+30°C MAXIMUM

REVISION: A1	ECR/ECN INFORMATION: EC No: KOR2016-0064 DATE: 2016 / 03 / 15	TITLE: LITE-TRAP CONNECTOR. BOTTOM ENTRY TYPE 1CKT, 2CKTS	SHEET No. 2 of 9
DOCUMENT NUMBER: PS-104266-001	CREATED / REVISED BY: JS.SHIN	CHECKED BY: SH.CHU	APPROVED BY: YSOO.KIM

molex[®] PRODUCT SPECIFICATION

5-2. MECHANICAL REQUIREMENTS(기계적 특성)

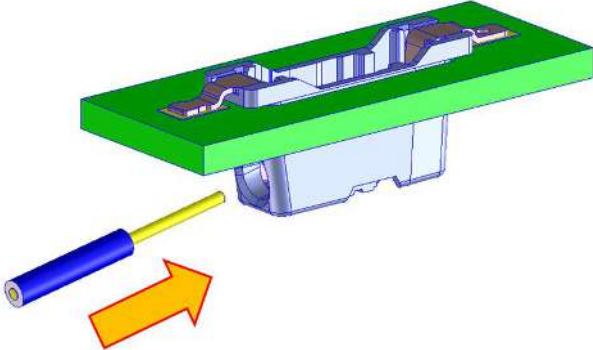
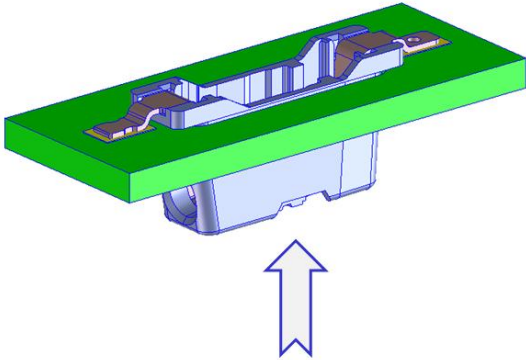
ITEM 항 목	TEST CONDITION 시 험 조 건	REQUIREMENT 규 격
<p>5</p> <p>Wire Insertion /Retention Forces Wire 삽입력 및 발거력</p>	<p>Insert Wire into the Connector and withdraw the wire from it at a rate of 25 ± 6 mm per minute. [When wire insertion condition : refer to 10]</p>  <p>Connector에 Wire를 각각 25 ± 6 mm/분의 속도로 삽입,발거를 실시한다.[와이어 삽입 조건 10항 참조]</p>	<p>Initial (초기) Wire Insertion force (Wire삽입력) : 10.0 N MAX.</p> <p>Wire Retention force (Wire 인발력) - AWG#24 : 28N Min. - AWG#22~AWG#18 : 50N MIN.</p>
<p>6</p> <p>PCB Retention Force PCB 접합력</p>	<p>After soldering the connector on PCB, measured the force to pull connector till connector solder part break away from PCB (Testing speed : 25 ± 6 mm per minute)</p>  <p>PCB에 커넥터를 솔더링 한 후, 25 ± 6 mm /분의 속도로 그림방향으로 힘을 가하여 PCB와 커넥터 솔더링부가 파손 될 때의 힘을 측정한다</p>	<p>-1CKT : 20 N MIN. -2CKTS : 30 N MIN.</p>

<p>REVISION:</p> <p>A1</p>	<p>ECR/ECN INFORMATION:</p> <p>EC No: KOR2016-0064</p> <p>DATE: 2016 / 03 / 15</p>	<p>TITLE:</p> <p>LITE-TRAP CONNECTOR. BOTTOM ENTRY TYPE 1CKT, 2CKTS</p>	<p>SHEET No.</p> <p>3 of 9</p>
<p>DOCUMENT NUMBER:</p> <p>PS-104266-001</p>	<p>CREATED / REVISED BY:</p> <p>JS.SHIN</p>	<p>CHECKED BY:</p> <p>SH.CHU</p>	<p>APPROVED BY:</p> <p>YSOO.KIM</p>

molex[®] PRODUCT SPECIFICATION

5-2. MECHANICAL REQUIREMENTS(기계적 특성)

ITEM 항 목	TEST CONDITION 시 험 조 건	REQUIREMENT 규 격
7 Vibration 내 진 동 성	<p>Mate connector & Wire and subject to the following vibration conditions: Vibration Frequency : 20 -500Hz , 3.10G Peak Duration : 15 minutes in each X.Y.Z axes</p> <p>커넥터와 Wire를 결합하여 아래 진동상태를 가한다. 진동수 : 20 -500Hz , 3.10G Peak 진동시간 : X.Y.Z축 각 15분</p> <p>(EIA 3624-28 Test condition D)</p>	<p>No Damage 이상 없을 것</p> <p>Contact Resistance (접촉저항) 30 milliohms MAXIMUM</p> <p>Discontinuity(순간단락) < 1 microsecond</p>
8 Shock (Mechanical) 내 충 격 성	<p>Mate connector & Wire and shock at 30 G's with ½ sine wave (11 milliseconds) shocks in the ±X,±Y,±Z axes (18 shocks total).</p> <p>커넥터와 Wire를 결합하여 반정현파 30G's (490ms²)의 충격을 ±X,±Y,±Z축 방향에 3회 가한다. (총 18회)</p> <p>(EIA 364-27 ,Test Condition H.)</p>	<p>No Damage 이상 없을 것</p> <p>Contact Resistance (접촉저항) 30 milliohms MAXIMUM</p> <p>Discontinuity(순간단락) < 1 microsecon</p>
9 Thermal Aging 내 열 성	<p>Mate connector & Wire : expose to: 648 hours at 105 ± 2°C</p> <p>커넥터와 Wire를 결합하여 주위온도 105 ± 2°C에서 648시간 방치 후 꺼내어 측정한다.</p> <p>(EIA 364-17 Method A, Test Condition 4.)</p>	<p>No Damage 이상 없을 것</p> <p>Contact Resistance (접촉저항) 30 milliohms MAXIMUM</p>
10 Cold Resistance 내 한 성	<p>Mate connector & Wire: Duration: 500 hours; Temperature: -60 ± 3°C</p> <p>주위온도 -60 ± 3°C에서 500시간 방치 후 꺼내어 측정한다.</p> <p>(EIA 364-59)</p>	<p>No Damage 이상 없을 것</p> <p>Contact Resistance (접촉저항) 30 milliohms MAXIMUM</p>

REVISION: A1	ECR/ECN INFORMATION: EC No: KOR2016-0064 DATE: 2016 / 03 / 15	TITLE: LITE-TRAP CONNECTOR. BOTTOM ENTRY TYPE 1CKT, 2CKTS	SHEET No. 4 of 9
DOCUMENT NUMBER: PS-104266-001	CREATED / REVISED BY: JS.SHIN	CHECKED BY: SH.CHU	APPROVED BY: YSOO.KIM

molex[®] PRODUCT SPECIFICATION

5-3. ENVIRONMENTAL REQUIREMENTS(환경적 특성)

ITEM 항 목		TEST CONDITION 시험 조건	REQUIREMENT 규 격						
11	Humidity (Steady State) 내 습 성	<p>Mate connector & Wire : expose to a temperature of $60 \pm 2^{\circ}\text{C}$ with a relative humidity of 90-95% for 500 hours.</p> <p>Note: Remove surface moisture and air dry for 1 hour prior to measurements.</p> <p>커넥터에 Wire를 결합하여 상대습도 90-95%, 온도 $60 \pm 2^{\circ}\text{C}$ 상태에서 500 시간 방치한다. 측정 전 수분을 제거하고 대기 에서 1시간 건조한다 (EIA 364-31)</p>	<p>No Damage 이상 없을 것</p> <p>Contact Resistance (접촉저항) : 30 milliohms MAXIMUM</p> <p>Insulation Resistance (절연저항) : 100 Mega-ohms MINIMUM</p> <p>Dielectric Withstanding Voltage (내전압) : No breakdown at 1,650 VAC</p>						
12	Temperature Cycling (Thermal) 열 충격	<p>Mate connector & Wire : expose to 25 cycles of: 커넥터에 Wire를 결합하여 아래 상태에서 25 cycles 방치.</p> <table border="1"> <thead> <tr> <th>Temperature $^{\circ}\text{C}$ 온도</th> <th>Duration (Minutes) 시간(분)</th> </tr> </thead> <tbody> <tr> <td>-60 +0/-3</td> <td>30</td> </tr> <tr> <td>+130 +3/-0</td> <td>30</td> </tr> </tbody> </table> <p>(EIA 364-32 Test Condition vii)</p>	Temperature $^{\circ}\text{C}$ 온도	Duration (Minutes) 시간(분)	-60 +0/-3	30	+130 +3/-0	30	<p>No Damage 이상 없을 것</p> <p>Contact Resistance (접촉저항) 30 milliohms MAXIMUM</p>
Temperature $^{\circ}\text{C}$ 온도	Duration (Minutes) 시간(분)								
-60 +0/-3	30								
+130 +3/-0	30								
13	Salt Spray 염 수 분 무	<p>Mate connector & Wire : Duration: 96 hours exposure; Atmosphere: salt spray from a 5% solution; Temperature: 35 +1/-2$^{\circ}\text{C}$</p> <p>주위온도 : 35 +1/-2$^{\circ}\text{C}$ 에서 5% 중량비의 염수를 96시간 분무하고 시험후 상온에서 물로 씻은후 실온에서 건조시킨다. (EIA 364-26)</p>	<p>No Damage 이상 없을 것</p> <p>Contact Resistance (접촉저항) 30 milliohms MAXIMUM</p>						
14	Humidity/ Temperature Cycling 온.습도 Cycle	<p>Mate connector & Wire on PCB : $25\sim 65^{\circ}\text{C}$, $80\sim 100\% \text{RH}$, 24hours a cycle, repeat 10 cycles.</p> <p>PCB 상에 Wire가 결합된 Connector를 25에서 65°C 사이의 온도에서 80%에서100% RH를 하루씩 10Cycle을 반복 한다 (EIA 364-31, Method viii)</p>	<p>No Damage 이상 없을 것</p> <p>Contact Resistance (접촉저항) 30 milliohms MAXIMUM</p>						

REVISION: A1	ECR/ECN INFORMATION: EC No: KOR2016-0064 DATE: 2016 / 03 / 15	TITLE: LITE-TRAP CONNECTOR. BOTTOM ENTRY TYPE 1CKT, 2CKTS	SHEET No. 5 of 9
DOCUMENT NUMBER: PS-104266-001	CREATED / REVISED BY: JS.SHIN	CHECKED BY: SH.CHU	APPROVED BY: YSOO.KIM

molex[®] PRODUCT SPECIFICATION

5-3. ENVIRONMENTAL REQUIREMENTS(환경적 특성)

ITEM 항 목		TEST CONDITION 시 험 조 건	REQUIREMENT 규 격
15	Solderability 납 땀 성	Storage for 4 hours at 155°C SOLDER(Sn3Ag0.5Cu) Solder Duration : 5 ± 0.5 seconds Solder Temperature : 260 ± 5°C 155°C 에서 4시간 보관 SOLDER(Sn3Ah0.5Cu) 납땀시간 : 5 ± 0.5 seconds 납땀온도: 260 ± 5°C (EIA 638, JESD22-B102D)	Solder coverage: 95% MINIMUM 95% MINIMUM 침적
16	Resistance to Sodering heat 납 땀 내 열 성	Reflow Soldering Method Reference reflow condition at 7 clause Reflow Soldering 방식일때 하기 제 7항 reflow 조건을 따른다.	Visual: No Damage to insulator material 외관 변형 없을 것
		Soldering iron method 0.2mm from terminal and nail tip Solder Duration: 3 ± 0.5 seconds; Solder Temperature: 350 ± 5°C Manual Soldering 방식일때 단자 끝단에서 0.2mm 거리 사이에서 납땀한다. 납땀시간 : 3 ± 0.5 seconds 납땀온도: 350 ± 5°C	
17	Hydrogen Sulfide Gas 황화 수소 가스	96 hours exposure to 3± 2 ppm hydrogen sulfide gas at 40 ± 2°C, 80 ± 5% 주위온도 40 ± 2°C, 습도 80 ± 5% 에서 3±1ppm의 황화수소 가스를 96시간 방치한다 (JISC 0092)	No Damage 이상 없을 것 Contact Resistance (접촉저항) 30 milliohms MAXIMUM
18	Ammonia Gas 암모니아 가스	7 hours exposure to NH3 gas evaporating from 3% ammonia 25ml/l suction 3%암모니아 25ml/l증발가스를 7시간 동안 노출시킨다.	No Damage 이상 없을 것 Contact Resistance (접촉저항) 30 milliohms MAXIMUM
19	Corrosive Atmosphere: Sulfur Dioxide Gas (SO₂) 아황산 가스	96 hours exposure to 25± 2 ppm SO ₂ gas at 40 ± 2°C ,80 ± 5% 주위온도 40 ± 2°C, 습도 80 ± 5%에서 25± 2ppm의 아황산가스에 96시간 방치한다. (JISC 0092)	No Damage 이상 없을 것 Contact Resistance (접촉저항) 30 milliohms MAXIMUM

REVISION: A1	ECR/ECN INFORMATION: EC No: KOR2016-0064 DATE: 2016 / 03 / 15	TITLE: LITE-TRAP CONNECTOR. BOTTOM ENTRY TYPE 1CKT, 2CKTS	SHEET No. 6 of 9
DOCUMENT NUMBER: PS-104266-001	CREATED / REVISED BY: JS.SHIN	CHECKED BY: SH.CHU	APPROVED BY: YSOO.KIM

molex[®] PRODUCT SPECIFICATION

6. PACKAGING

Parts shall be packaged to protect against damage during handling, transit and storage.
See Packaging drawing PK-104266-001 for more information.

7. REFLOW CONDITION (REFLOW 조건)

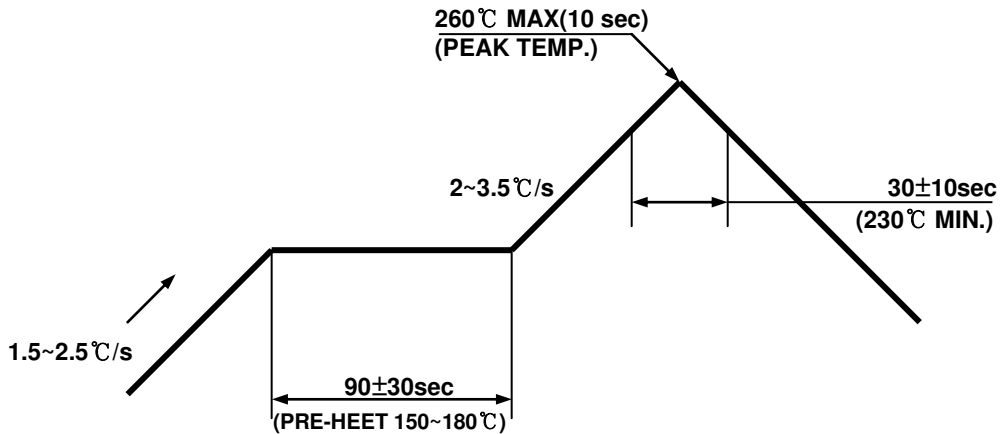

Temperature Condition Graph(온도조건 그래프)

(Temperature on board pattern side)

Reflow possibility : 2 times

(Reflow 횟수 : 2회 이하 가능)

Note : Please check the reflow soldering condition by your own devices beforehand.

Because the condition changes by the soldering devices, P.C.Board, and so on.

(본 Reflow조건은 Reflow 장치 및 기판 조건 등에 의해서 다를 수가 있으므로,
사전에 Reflow조건을 확인하여 주십시오)

REVISION: A1	ECR/ECN INFORMATION: EC No: KOR2016-0064 DATE: 2016 / 03 / 15	TITLE: LITE-TRAP CONNECTOR. BOTTOM ENTRY TYPE 1CKT, 2CKTS	SHEET No. 7 of 9
DOCUMENT NUMBER: PS-104266-001	CREATED / REVISED BY: JS.SHIN	CHECKED BY: SH.CHU	APPROVED BY: YSOO.KIM

molex[®] PRODUCT SPECIFICATION

8. APPLICABLE WIRES [적용 WIRE]

Wire Range AWG No.	Number of Conductors / Diameter of a conductors (Cross-sectional area of conductors / mm ²)	Insulation Diameter (mm) 2.1mm Max.	Conductor Type
24	1 / 0.51 (0.2mm ²)	1.35	Solid
22	1 / 0.64(0.3mm ²)	1.48	
20	1 / 0.81(0.5mm ²)	1.65	
18	1 / 1.02(0.75mm ²)	1.86	
24	11/0.16 (Reference) After soldering : Ø 0.75mm Max.	1.45	Strand
22	17/0.76 (Reference) After soldering : Ø 0.9mm Max.	1.60	
20	21/0.95 (Reference) After soldering : Ø 1.1mm Max	1.78	

☐ Regarding strand conductor wire, strictly recommend that Pre bond wire type which is dipping into soldering after twisting
[Strand 심선 Wire관련, Wire Twisting 후 Soldering을 하는 Pre bond 형식을 추천함.]

9. WIRE STRIP LENGTH [Wire 탈피 길이]

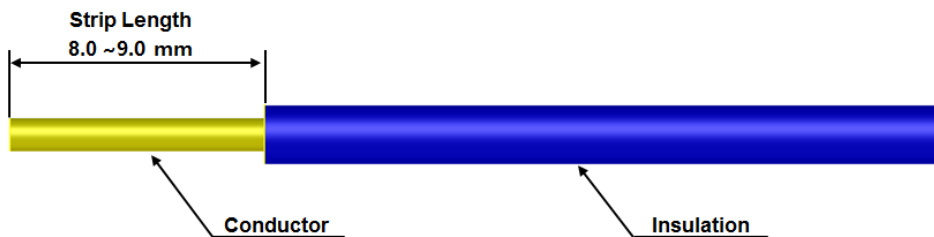

[Conductor : Bare Copper /Strand wire]

Acceptable	Non-Acceptable
<p>Strand Wire Solid Wire</p>	<p>The insulation, conductor not be damaged in any way.</p>

REVISION: A1	ECR/ECN INFORMATION: EC No: KOR2016-0064 DATE: 2016 / 03 / 15	TITLE: LITE-TRAP CONNECTOR. BOTTOM ENTRY TYPE 1CKT, 2CKTS	SHEET No. 8 of 9
DOCUMENT NUMBER: PS-104266-001	CREATED / REVISED BY: JS.SHIN	CHECKED BY: SH.CHU	APPROVED BY: YSOO.KIM

molex[®] PRODUCT SPECIFICATION

10. WIRE INSERTION [Wire 삽입]

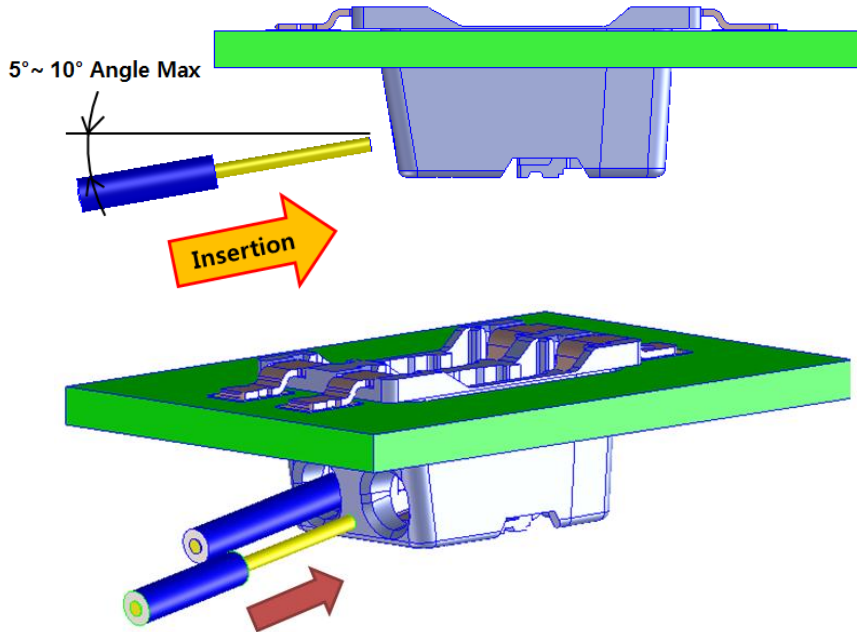

11. The Method of Wire Separation from connected connector [커넥터로부터 Wire 분리 방법]

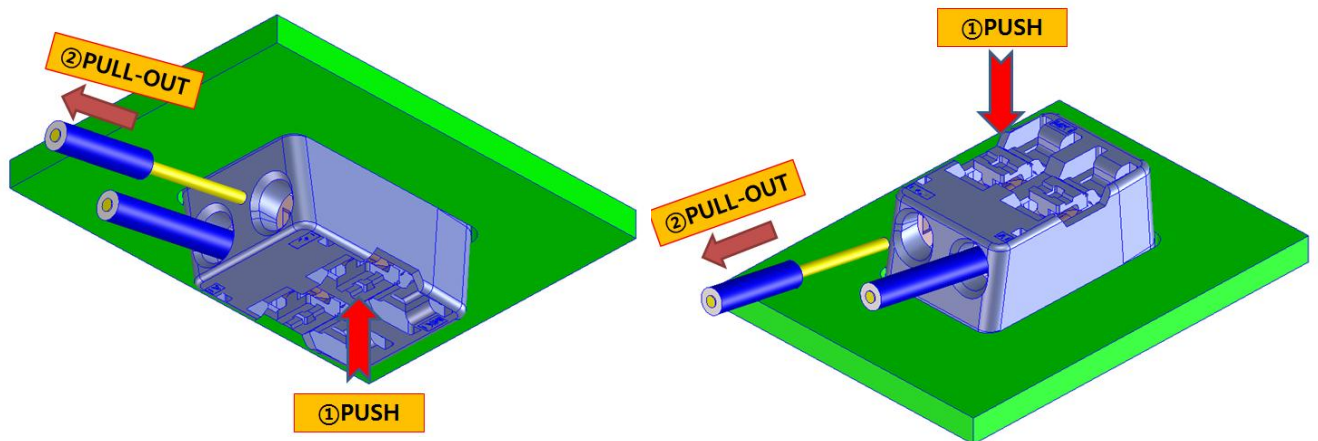

1) Push the Lever slightly with fingers or tools to separate the wire.

[Lever 를 손가락이나 Tool 로 가볍게 눌러 Wire 를 분리한다.]

2) Pull the wire after push the Lever had better than Pull the wire and push the lever at the same time.

[동시에 Lever 을 누르면서 Wire 를 당기면서 Wire 을 분리 하는 것보다 Lever 을 누른 후 Wire 를 당겨 분리 한다.]

3) The tip for the easy way to separate the wire is that push the wire forward slightly then push the lever.

[Wire 를 쉽게 빼는 방법은 앞으로 Wire 를 살짝 밀고 Push Lever 을 누르면 더 용이 하게 Wire 를 분리]

※ Use the new conductor cutting off the wire if it used more than 3 times [for the wire wearing]

[3 회이상 사용한 Wire 는 절단 후 새로운 심선을 탈피 하여 사용 할 것 [Wire 마모 현상]

REVISION: A1	ECR/ECN INFORMATION: EC No: KOR2016-0064 DATE: 2016 / 03 / 15	TITLE: LITE-TRAP CONNECTOR. BOTTOM ENTRY TYPE 1CKT, 2CKTS	SHEET No. 9 of 9
DOCUMENT NUMBER: PS-104266-001	CREATED / REVISED BY: JS.SHIN	CHECKED BY: SH.CHU	APPROVED BY: YSOO.KIM