

LM60 2.7-V, SOT-23 or TO-92 Temperature Sensor

1 Features

- Calibrated Linear Scale Factor of 6.25 mV/°C
- Rated for Full -40°C to +125°C Range
- Suitable for Remote Applications
- Available in SOT-23 and TO-92 Packages
- Key Specifications
 - Accuracy at 25°C: ±2°C and ±3°C (Maximum)
 - Accuracy for -40°C to +125°C: ±4°C (Maximum)
 - Accuracy for -25°C to +125°C: ±3°C (Maximum)
 - Temperature Slope: 6.25 mV/°C
 - Power-Supply Voltage Range: 2.7 V to 10 V
 - Current Drain at 25°C: 110 µA (Maximum)
 - Nonlinearity: ±0.8°C (Maximum)
 - Output Impedance: 800 Ω (Maximum)

2 Applications

- Cell Phones and Computers
- Power Supply Modules
- Battery Management
- Fax Machines and Printers
- HVAC and Disk Drives
- Appliances

3 Description

The LM60 device is a precision integrated-circuit temperature sensor that can sense a -40°C to +125°C temperature range while operating from a single 2.7-V supply. The output voltage of the device is linearly proportional to Celsius (Centigrade) temperature (6.25 mV/°C) and has a DC offset of 424 mV. The offset allows reading negative temperatures without the need for a negative supply. The nominal output voltage of the device ranges from 174 mV to 1205 mV for a -40°C to +125°C temperature range. The device is calibrated to provide accuracies of ±2°C at room temperature and ±3°C over the full -25°C to +125°C temperature range.

The linear output of the device, 424-mV offset, and factory calibration simplify external circuitry required in a single supply environment where reading negative temperatures is required. Because the quiescent current of the device is less than 110 µA, self-heating is limited to a very low 0.1°C in still air in the SOT-23 package. Shutdown capability for the device is intrinsic because its inherent low power consumption allows it to be powered directly from the output of many logic gates.

Device Information⁽¹⁾

PART NUMBER	PACKAGE	BODY SIZE (NOM)
LM60	TO-92 (3)	4.30 mm × 4.30 mm
	SOT-23 (3)	2.92 mm × 1.30 mm

(1) For all available packages, see the orderable addendum at the end of the data sheet.

Simplified Schematic

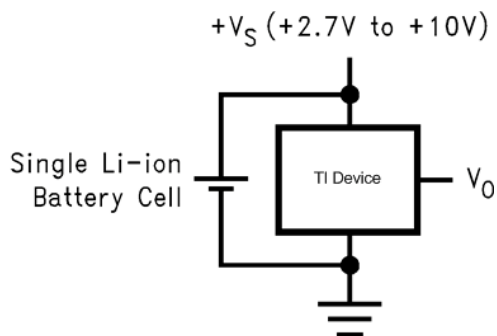

Copyright © 2017, Texas Instruments Incorporated

Full-Range Centigrade Temperature Sensor (-40°C to +125°C)

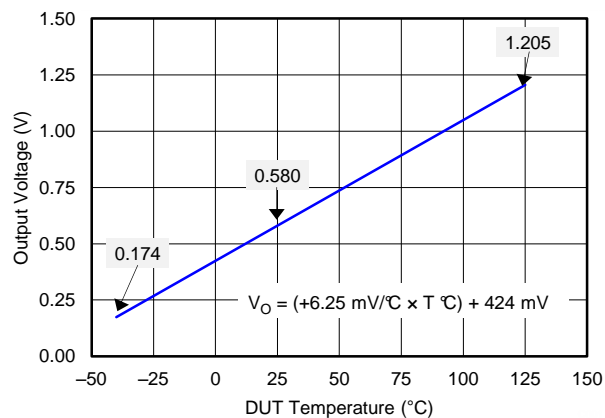

Table of Contents

1 Features	1	8.4 Device Functional Modes.....	9
2 Applications	1	9 Application and Implementation	10
3 Description	1	9.1 Application Information.....	10
4 Revision History	2	9.2 Typical Applications	11
5 Device Comparison Table	3	9.3 System Examples	13
6 Pin Configuration and Functions	4	10 Power Supply Recommendations	13
7 Specifications	4	11 Layout	14
7.1 Absolute Maximum Ratings	4	11.1 Layout Guidelines	14
7.2 ESD Ratings	4	11.2 Layout Example	14
7.3 Recommended Operating Conditions.....	5	11.3 Thermal Considerations.....	14
7.4 Thermal Information	5	12 Device and Documentation Support	16
7.5 Electrical Characteristics.....	5	12.1 Receiving Notification of Documentation Updates	16
7.6 Typical Characteristics	7	12.2 Community Resources.....	16
8 Detailed Description	9	12.3 Trademarks	16
8.1 Overview	9	12.4 Electrostatic Discharge Caution.....	16
8.2 Functional Block Diagram	9	12.5 Glossary	16
8.3 Feature Description.....	9	13 Mechanical, Packaging, and Orderable Information	16

4 Revision History

Changes from Revision E (September 2015) to Revision F

Page

• Moved the automotive device to a standalone data sheet (SNIS197)	1
• Added tablenote for the LM60B.....	3
• Added tablenote for the LM60B.....	5

Changes from Revision D (November 2012) to Revision E

Page

• Added <i>Pin Configuration and Functions</i> section, <i>ESD Ratings</i> table, <i>Feature Description</i> section, <i>Device Functional Modes</i> , <i>Application and Implementation</i> section, <i>Power Supply Recommendations</i> section, <i>Layout</i> section, <i>Device and Documentation Support</i> section, and <i>Mechanical, Packaging, and Orderable Information</i> section	1
--	----------

5 Device Comparison Table

ORDER NUMBER	ACCURACY OVER SPECIFIED TEMPERATURE RANGE	SPECIFIED TEMPERATURE RANGE
LM60BIM3	±3	–25°C ≤ T _A ≤ +125°C ⁽¹⁾
LM60BIM3X		
LM60CIM3	±4	–40°C ≤ T _A ≤ +125°C
LM60CIM3X		
LM60QIM3	±4	–40°C ≤ T _A ≤ +125°C
LM60QIM3X		
LM60BIZ	±3	–25°C ≤ T _A ≤ +125°C
LM60CIZ	±4	–40°C ≤ T _A ≤ +125°C

(1) LM60B will operate down to –40°C without damage but the accuracy is only ensured from –25°C to 125°C.

6 Pin Configuration and Functions



Pin Functions

NAME	PIN		TYPE	DESCRIPTION
	SOT-23	TO92		
GND	3	3	GND	Device ground, connected to power supply negative terminal
V _{OUT}	2	2	O	Temperature sensor analog output
+V _S	1	1	POWER	Positive power supply pin

7 Specifications

7.1 Absolute Maximum Ratings

over operating free-air temperature range (unless otherwise noted)⁽¹⁾

	MIN	MAX	UNIT
Supply voltage	-0.2	12	V
Output voltage	-0.6	V _S + 0.6	V
Output current		10	mA
Input current at any pin ⁽²⁾		5	mA
Maximum junction temperature (T _{JMAX})		125	°C
Storage temperature (T _{stg})	-65	150	°C

- (1) Stresses beyond those listed under *Absolute Maximum Ratings* may cause permanent damage to the device. These are stress ratings only, which do not imply functional operation of the device at these or any other conditions beyond those indicated under *Recommended Operating Conditions*. Exposure to absolute-maximum-rated conditions for extended periods may affect device reliability.
- (2) When the input voltage (V_I) at any pin exceeds power supplies (V_I < GND or V_I > +V_S), the current at that pin should be limited to 5 mA.

7.2 ESD Ratings

		VALUE	UNIT
LM60 in DBZ Package			
V _(ESD) Electrostatic discharge ⁽¹⁾	Human-body model (HBM)	±2500	V
	Machine model (MM)	±250	
LM60 in LP Package			
V _(ESD) Electrostatic discharge ⁽¹⁾	Human-body model (HBM)	±2500	V
	Machine model (MM)	±200	

- (1) The human body model is a 100-pF capacitor discharged through a 1.5-kΩ resistor into each pin. The machine model is a 200-pF capacitor discharged directly into each pin.

7.3 Recommended Operating Conditions

over operating free-air temperature range (unless otherwise noted)⁽¹⁾

	MIN	MAX	UNIT
LM60B ($T_{MIN} \leq T_A \leq T_{MAX}$)	-25 ⁽²⁾	125	°C
LM60C ($T_{MIN} \leq T_A \leq T_{MAX}$)	-40	125	°C
Supply voltage (+V _S)	2.7	10	V

- (1) Soldering process must comply with National Semiconductor's Reflow Temperature Profile specifications. Refer to www.national.com/packaging. Reflow temperature profiles are different for lead-free and non-lead-free packages.
- (2) LM60B will operate down to -40°C without damage but the accuracy is only ensured from -25°C to 125°C.

7.4 Thermal Information

THERMAL METRIC ⁽¹⁾		LM60		UNIT
		DBZ (SOT-23)	LP (TO-92)	
		3 PINS	3 PINS	
R _{θJA} ⁽²⁾	Junction-to-ambient thermal resistance	266	162	°C/W
R _{θJC(top)}	Junction-to-case (top) thermal resistance	135	85	°C/W
R _{θJB}	Junction-to-board thermal resistance	59	—	°C/W
ψ _{JT}	Junction-to-top characterization parameter	18	29	°C/W
ψ _{JB}	Junction-to-board characterization parameter	58	142	°C/W

- (1) For more information about traditional and new thermal metrics, see the [Semiconductor or IC Package Thermal Metrics](#) application report.
- (2) The junction to ambient thermal resistance (R_{θJA}) is specified without a heat sink in still air.

7.5 Electrical Characteristics

Unless otherwise noted, these specifications apply for +V_S = 3 V_{DC} and I_{LOAD} = 1 μA. All limits T_A = T_J = 25°C unless otherwise noted.

PARAMETER	TEST CONDITIONS		MIN ⁽¹⁾	TYP ⁽²⁾	MAX ⁽¹⁾	UNIT
Accuracy ⁽³⁾	LM60B		-2		2	°C
		T _A = T _J = T _{MIN} to T _{MAX}	-3		3	
	LM60C		-3		3	°C
		T _A = T _J = T _{MIN} to T _{MAX}	-4		4	
Output voltage at 0°C				424		mV
Nonlinearity ⁽⁴⁾	LM60B	T _A = T _J = T _{MIN} to T _{MAX}	-0.6		±0.6	°C
	LM60C	T _A = T _J = T _{MIN} to T _{MAX}	-0.8		±0.8	
Sensor gain (average slope)				6.25		mV/°C
	LM60B	T _A = T _J = T _{MIN} to T _{MAX}	6.06		6.44	
	LM60C	T _A = T _J = T _{MIN} to T _{MAX}	6		6.5	
Output impedance	T _A = T _J = T _{MIN} to T _{MAX}				800	Ω

- (1) Limits are specified to TI's AOQL (Average Outgoing Quality Level).
- (2) Typicals are at T_J = T_A = 25°C and represent most likely parametric norm.
- (3) Accuracy is defined as the error between the output voltage and 6.25 mV/°C times the case temperature of the device plus 424 mV, at specified conditions of voltage, current, and temperature (expressed in °C).
- (4) Nonlinearity is defined as the deviation of the output-voltage-versus-temperature curve from the best-fit straight line, over the rated temperature range of the device.

Electrical Characteristics (continued)

Unless otherwise noted, these specifications apply for $+V_S = 3 V_{DC}$ and $I_{LOAD} = 1 \mu A$. All limits $T_A = T_J = 25^\circ C$ unless otherwise noted.

PARAMETER	TEST CONDITIONS		MIN ⁽¹⁾	TYP ⁽²⁾	MAX ⁽¹⁾	UNIT
Line regulation ⁽⁵⁾	$3 V \leq +V_S \leq 10 V$	$T_A = T_J = T_{MIN}$ to T_{MAX}	-0.3		0.3	mV/V
	$2.7 V \leq +V_S \leq 3.3 V$	$T_A = T_J = T_{MIN}$ to T_{MAX}	-2.3		2.3	mV
Quiescent current	$2.7 V \leq +V_S \leq 10 V$			82	110	μA
		$T_A = T_J = T_{MIN}$ to T_{MAX}			125	μA
Change of quiescent current	$2.7 V \leq +V_S \leq 10 V$			± 5		μA
Temperature coefficient of quiescent current				0.2		$\mu A/^\circ C$
Long-term stability ⁽⁶⁾	$T_J = T_{MAX} = 125^\circ C$ for 1000 hours			± 0.2		$^\circ C$

- (5) Regulation is measured at constant junction temperature, using pulse testing with a low duty cycle. Changes in output due to heating effects can be computed by multiplying the internal dissipation by the thermal resistance.
- (6) For best long-term stability, any precision circuit will give best results if the unit is aged at a warm temperature, temperature cycled for at least 46 hours before long-term life test begins for both temperatures. This is especially true when a small (surface-mount) part is wave-soldered; allow time for stress relaxation to occur. The majority of the drift will occur in the first 1000 hours at elevated temperatures. The drift after 1000 hours will not continue at the first 1000 hour rate.

7.6 Typical Characteristics

To generate these curves, the device was mounted to a printed-circuit board as shown in [Figure 20](#).

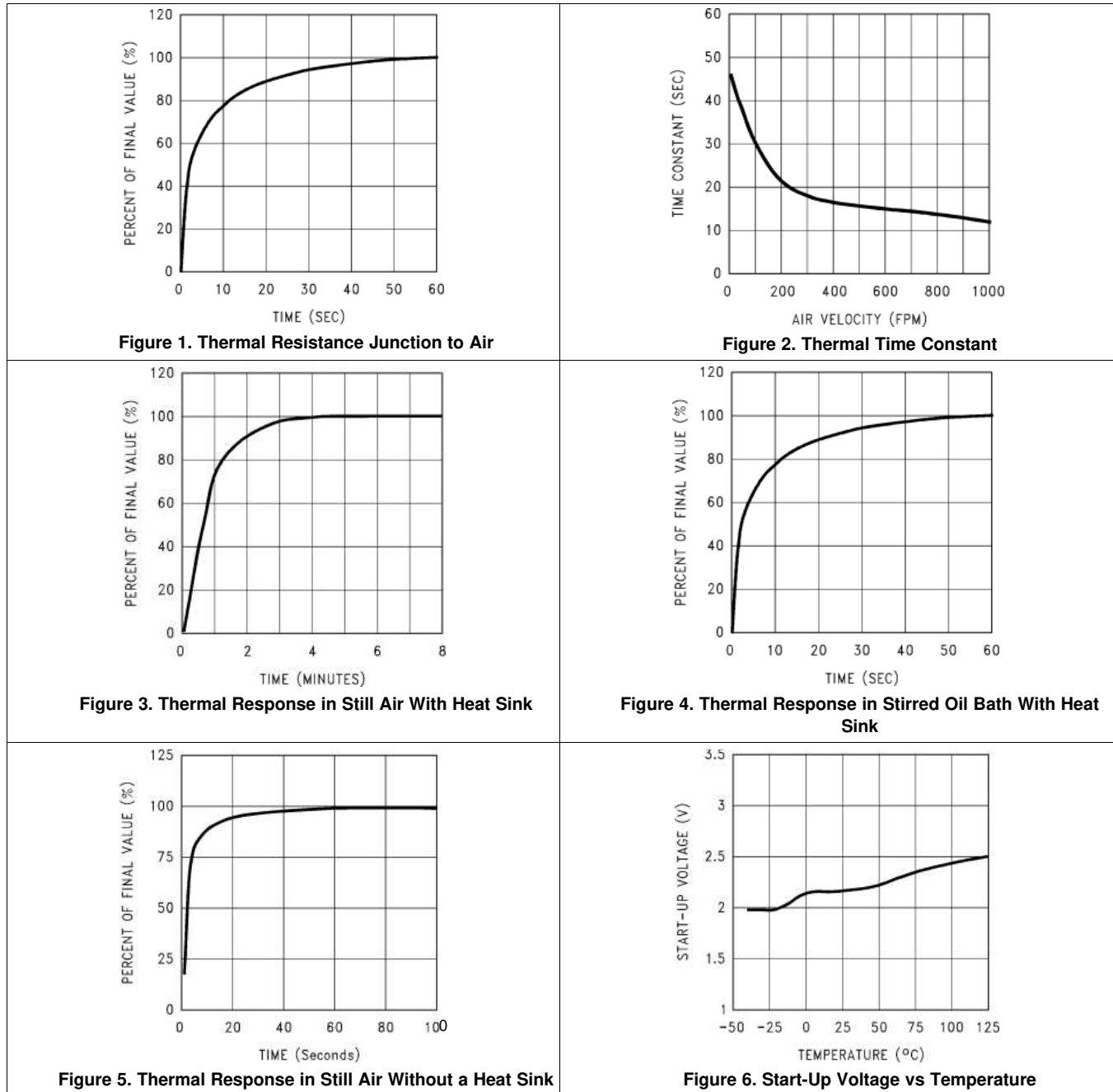

Typical Characteristics (continued)

To generate these curves, the device was mounted to a printed-circuit board as shown in [Figure 20](#).

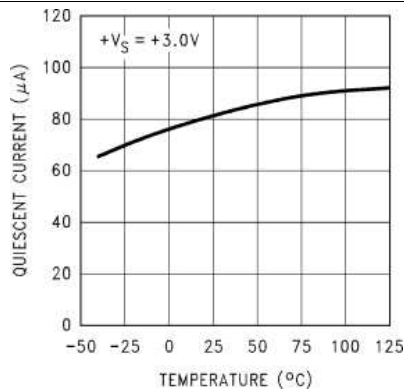

Figure 7. Quiescent Current vs Temperature

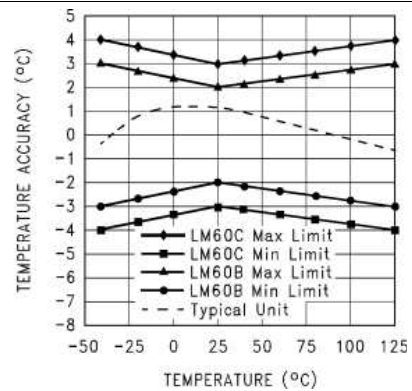

Figure 8. Accuracy vs Temperature

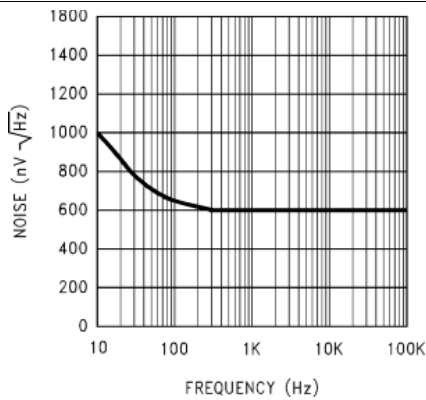

Figure 9. Noise Voltage

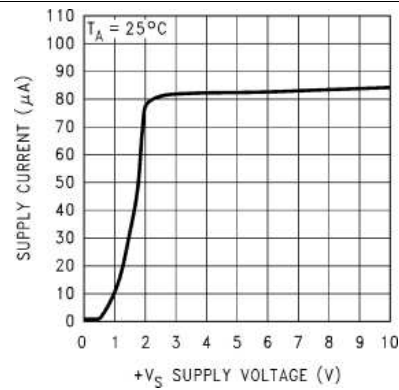

Figure 10. Supply Voltage vs Supply Current

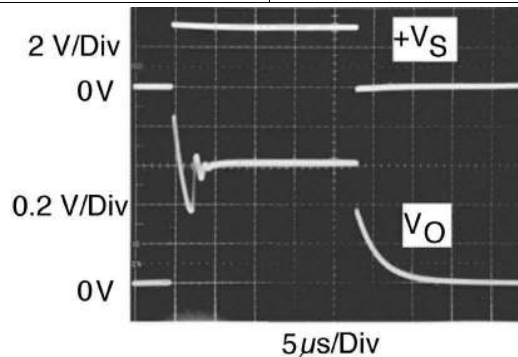

Figure 11. Start-Up Response

8 Detailed Description

8.1 Overview

The LM60 devices are precision analog bipolar temperature sensors that can sense a -40°C to $+125^{\circ}\text{C}$ temperature range while operating from a single 2.7-V supply. The output voltage of the LM60 is linearly proportional to Celsius (Centigrade) temperature ($6.25\text{ mV}/^{\circ}\text{C}$) and has a DC offset of 424 mV. The offset allows reading negative temperatures with a single positive supply. The nominal output voltage of the device ranges from 174 mV to 1205 mV for a -40°C to $+125^{\circ}\text{C}$ temperature range. The device is calibrated to provide accuracies of $\pm 2.0^{\circ}\text{C}$ at room temperature and $\pm 3^{\circ}\text{C}$ over the full -25°C to $+125^{\circ}\text{C}$ temperature range.

With a quiescent current of the device is less than $110\text{ }\mu\text{A}$, self-heating is limited to a very low 0.1°C in still air in the SOT-23 package. Shutdown capability for the device is intrinsic because its inherent low power consumption allows it to be powered directly from the output of many logic gates.

The output of the LM60 is a Class A base emitter follower, thus the LM60 can source quite a bit of current while sinking less than $1\text{ }\mu\text{A}$. In any event load current should be minimized in order to limit its contribution to the total temperature error. The temperature-sensing element is based on a delta V_{BE} topology of two transistors (Q1 and Q2 in [Functional Block Diagram](#)) that are sized with a 10:1 area ratio.

8.2 Functional Block Diagram

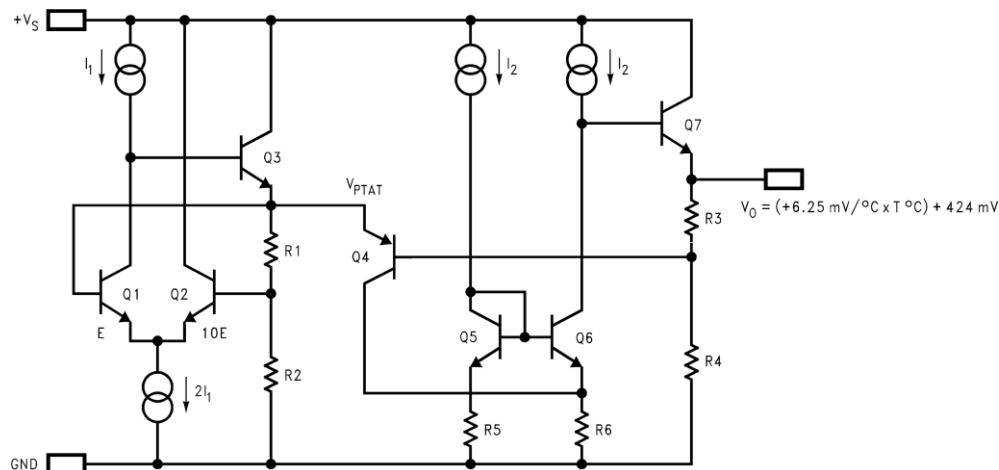

8.3 Feature Description

8.3.1 LM60 Transfer Function

The LM60 follows a simple linear transfer function to achieve the accuracy as listed in [Electrical Characteristics](#) as given:

$$V_O = (6.25\text{ mV}/^{\circ}\text{C} \times T\text{ }^{\circ}\text{C}) + 424\text{ mV}$$

where

- T is the temperature
- V_O is the LM60 output voltage

(1)

8.4 Device Functional Modes

The only functional mode for this device is an analog output directly proportional to temperature.

9 Application and Implementation

NOTE

Information in the following applications sections is not part of the TI component specification, and TI does not warrant its accuracy or completeness. TI's customers are responsible for determining suitability of components for their purposes. Customers should validate and test their design implementation to confirm system functionality.

9.1 Application Information

The device has a low supply current and a wide supply range, therefore it can easily be driven by a battery.

9.1.1 Capacitive Loads

The device handles capacitive loading well. Without any special precautions, the device can drive any capacitive load as shown in [Figure 12](#). Over the specified temperature range the device has a maximum output impedance of 800 Ω . In an extremely noisy environment, adding some filtering to minimize noise pick-up may be required. TI recommends that 0.1 μF be added from $+V_S$ to GND to bypass the power supply voltage, as shown in [Figure 13](#). In a noisy environment, adding a capacitor from the output to ground may be required. A 1- μF output capacitor with the 800- Ω output impedance forms a 199-Hz, low-pass filter. Because the thermal time constant of the device is much slower than the 6.3-ms time constant formed by the RC, the overall response time of the device is not significantly affected. For much larger capacitors, this additional time lag increases the overall response time of the device.

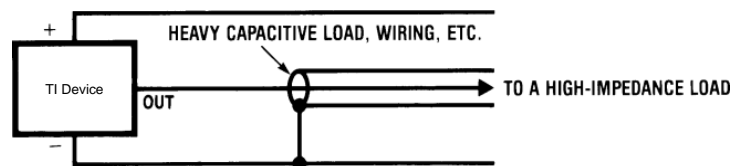

Copyright © 2017, Texas Instruments Incorporated

Figure 12. No Decoupling Required for Capacitive Load

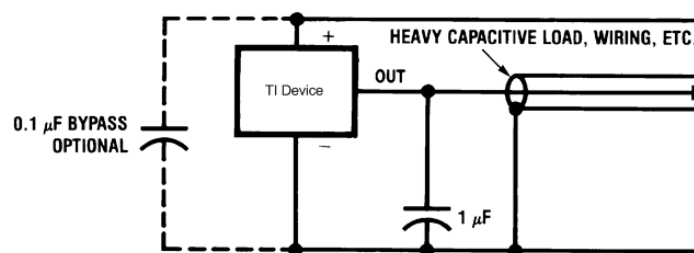

Copyright © 2017, Texas Instruments Incorporated

Figure 13. Filter Added for Noisy Environment

9.2 Typical Applications

9.2.1 Full-Range Centigrade Temperature Sensor

Because the LM60 is a simple temperature sensor that provides an analog output, design requirements related to the layout are also important. Refer to [Layout](#) for details.

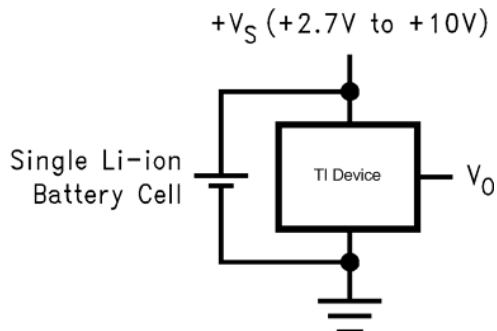

Copyright © 2017, Texas Instruments Incorporated

$$V_O = (6.25 \text{ mV/}^\circ\text{C} \times T^\circ\text{C}) + 424 \text{ mV}$$

Figure 14. Full-Range Centigrade Temperature Sensor (–40°C to +125°C) Operating From a Single Li-Ion Battery Cell

9.2.1.1 Design Requirements

For this design example, use the design parameters listed in [Table 1](#).

Table 1. Temperature and Typical V_O Values of [Figure 14](#)

TEMPERATURE (T)	TYPICAL V _O
125°C	1205 mV
100°C	1049 mV
25°C	580 mV
0°C	424 mV
–25°C	268 mV
–40°C	174 mV

9.2.1.2 Detailed Design Procedure

Selection of the LM60 is based on the output voltage transfer function being able to meet the needs of the rest of the system.

9.2.1.3 Application Curve

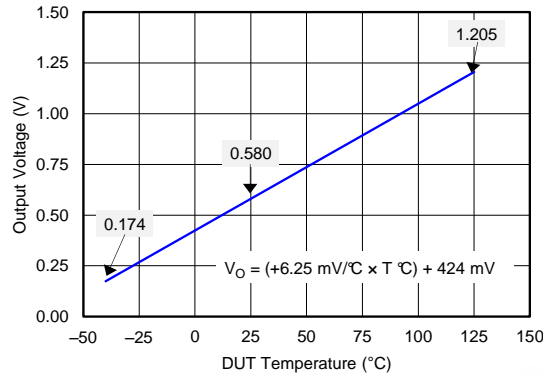
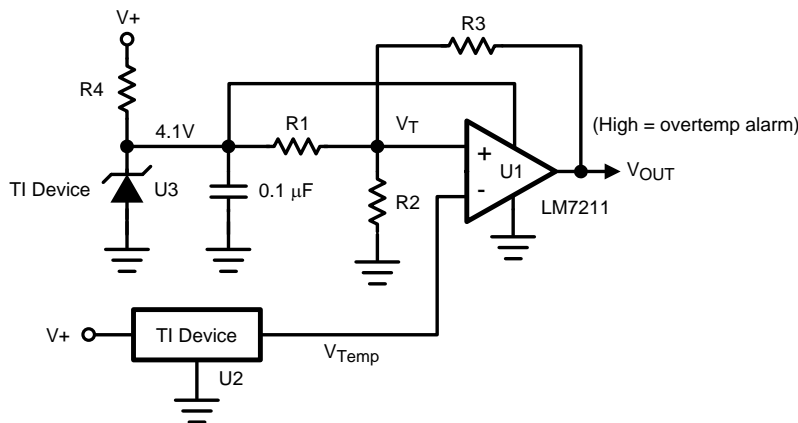

Figure 15. LM60 Output Transfer Function

9.2.2 Centigrade Thermostat Application



Copyright © 2017, Texas Instruments Incorporated

Figure 16. Centigrade Thermostat

9.2.2.1 Design Requirements

A simple thermostat can be created by using a reference (LM4040) and a comparator (LM7211) as shown in Figure 16.

9.2.2.2 Detailed Design Procedure

Use Equation 2 and Equation 3 to calculate the threshold values for T1 and T2.

$$V_{T1} = \frac{(4.1)R2}{R2 + R1 || R3} \tag{2}$$

$$V_{T2} = \frac{(4.1)R2 || R3}{R1 + R2 || R3} \tag{3}$$

9.2.2.3 Application Curve

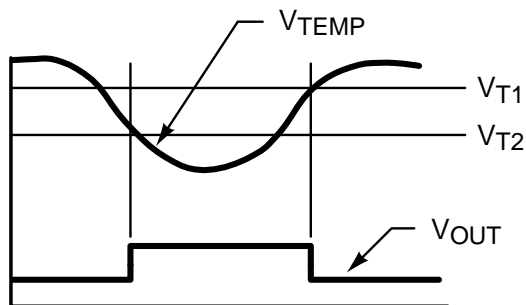
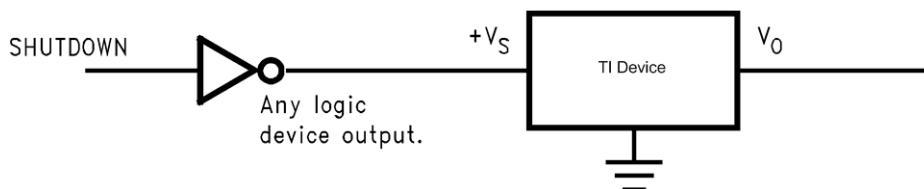

Figure 17. Thermostat Output Waveform

9.3 System Examples

9.3.1 Conserving Power Dissipation With Shutdown

The LM60 draws very little power, therefore it can simply be shutdown by driving the LM60 supply pin with the output of a logic gate as shown in Figure 18.



Copyright © 2017, Texas Instruments Incorporated

Figure 18. Conserving Power Dissipation With Shutdown

10 Power Supply Recommendations

In an extremely noisy environment, add some filtering to minimize noise pick-up. Adding 0.1 μF from $+V_S$ to GND is recommended to bypass the power supply voltage, as shown in Figure 13. In a noisy environment, add a capacitor from the output to ground.

11 Layout

11.1 Layout Guidelines

The LM60 can be applied easily in the same way as other integrated-circuit temperature sensors. It can be glued or cemented to a surface. The temperature that the LM60 is sensing will be within about +0.1°C of the surface temperature that the leads of th LM60 are attached to.

This presumes that the ambient air temperature is almost the same as the surface temperature. If the air temperature were much higher or lower than the surface temperature, the actual temperature of the device die would be at an intermediate temperature between the surface temperature and the air temperature.

To ensure good thermal conductivity the backside of the device die is directly attached to the GND pin. The lands and traces to the device will, of course, be part of the printed-circuit board, which is the object whose temperature is being measured. These printed-circuit board lands and traces do not cause the temperature of the device to deviate from the desired temperature.

Alternatively, the device can be mounted inside a sealed-end metal tube, and can then be dipped into a bath or screwed into a threaded hole in a tank. As with any IC, the device and accompanying wiring and circuits must be kept insulated and dry to avoid leakage and corrosion. Specifically when the device operates at cold temperatures where condensation can occur. Printed-circuit coatings and varnishes such as a conformal coating and epoxy paints or dips are often used to ensure that moisture cannot corrode the device or connections.

11.2 Layout Example

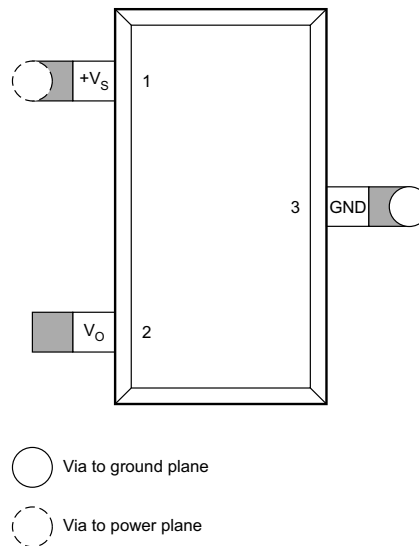

1/2-inch square printed circuit board with 2-oz. copper foil or similar.

Figure 19. PCB Layout

11.3 Thermal Considerations

The thermal resistance junction to ambient ($R_{\theta JA}$) is the parameter used to calculate the rise of a device junction temperature due to the device power dissipation. Use [Equation 4](#) to calculate the rise in the die temperature of the device.

$$T_J = T_A + R_{\theta JA} [(+V_S I_Q) + (+V_S - V_O) I_L]$$

where

- I_Q is the quiescent current
- I_L is the load current on the output

(4)

Thermal Considerations (continued)

Table 2 summarizes the rise in die temperature of the LM60 without any loading, and the thermal resistance for different conditions. The values in Table 2 were actually measured where as the values shown in Thermal Information were calculated using modeling methods as described in the *Semiconductor and IC Package Thermal Metrics* (SPRA953) application report.

Table 2. Temperature Rise of LM60 Due to Self-Heating and Thermal Resistance ($R_{\theta JA}$)

	SOT-23 ⁽¹⁾ NO HEAT SINK		SOT-23 ⁽²⁾ SMALL HEAT FIN		TO-92 ⁽¹⁾ NO HEAT FIN		TO-92 ⁽³⁾ SMALL HEAT FIN	
	$R_{\theta JA}$	$T_J - T_A$	$R_{\theta JA}$	$T_J - T_A$	$R_{\theta JA}$	$T_J - T_A$	$R_{\theta JA}$	$T_J - T_A$
	(°C/W)	(°C)	(°C/W)	(°C)	(°C/W)	(°C)	(°C/W)	(°C)
Still air	450	0.17	260	0.1	180	0.07	140	0.05
Moving air	—	—	180	0.07	90	0.034	70	0.026

- (1) Part soldered to 30 gauge wire.
- (2) Heat sink used is 1/2-in square printed-circuit board with 2-oz. foil with part attached as shown in Figure 20.
- (3) Part glued or leads soldered to 1-in square of 1/16-in printed-circuit board with 2-oz. foil or similar.

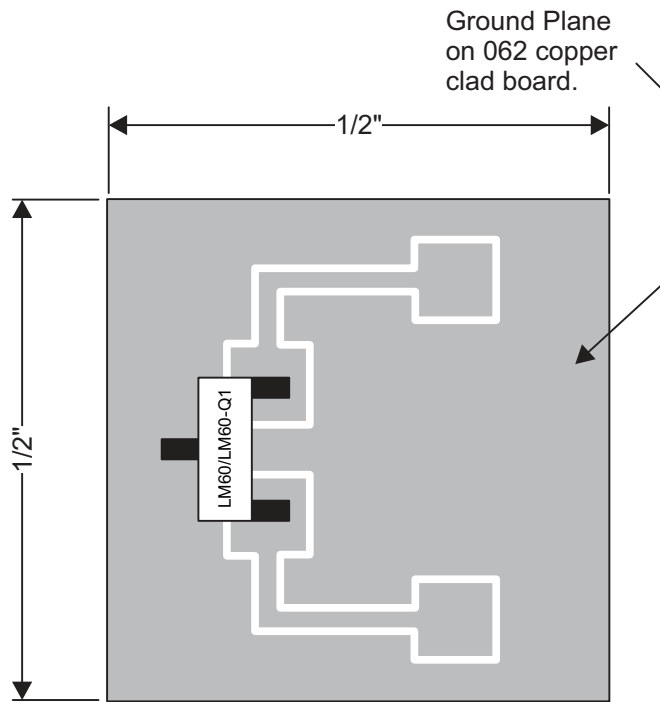

1/2-in Square Printed-Circuit Board with 2-oz. Copper Foil or Similar.

Figure 20. Printed-Circuit Board Used for Heat Sink to Generate Thermal Response Curves

12 Device and Documentation Support

12.1 Receiving Notification of Documentation Updates

To receive notification of documentation updates, navigate to the device product folder on ti.com. In the upper right corner, click on *Alert me* to register and receive a weekly digest of any product information that has changed. For change details, review the revision history included in any revised document.

12.2 Community Resources

The following links connect to TI community resources. Linked contents are provided "AS IS" by the respective contributors. They do not constitute TI specifications and do not necessarily reflect TI's views; see TI's [Terms of Use](#).

TI E2E™ Online Community *TI's Engineer-to-Engineer (E2E) Community*. Created to foster collaboration among engineers. At e2e.ti.com, you can ask questions, share knowledge, explore ideas and help solve problems with fellow engineers.

Design Support *TI's Design Support* Quickly find helpful E2E forums along with design support tools and contact information for technical support.

12.3 Trademarks

E2E is a trademark of Texas Instruments.
All other trademarks are the property of their respective owners.

12.4 Electrostatic Discharge Caution



These devices have limited built-in ESD protection. The leads should be shorted together or the device placed in conductive foam during storage or handling to prevent electrostatic damage to the MOS gates.

12.5 Glossary

[SLYZ022](#) — *TI Glossary*.

This glossary lists and explains terms, acronyms, and definitions.

13 Mechanical, Packaging, and Orderable Information

The following pages include mechanical, packaging, and orderable information. This information is the most current data available for the designated devices. This data is subject to change without notice and revision of this document. For browser-based versions of this data sheet, refer to the left-hand navigation.

PACKAGING INFORMATION

Orderable Device	Status (1)	Package Type	Package Drawing	Pins	Package Qty	Eco Plan (2)	Lead finish/ Ball material (6)	MSL Peak Temp (3)	Op Temp (°C)	Device Marking (4/5)	Samples
LM60BIM3	NRND	SOT-23	DBZ	3	1000	Non-RoHS & Green	Call TI	Level-1-260C-UNLIM	-25 to 125	T6B	
LM60BIM3/NOPB	ACTIVE	SOT-23	DBZ	3	1000	RoHS & Green	SN	Level-1-260C-UNLIM	-25 to 125	T6B	Samples
LM60BIM3X	NRND	SOT-23	DBZ	3	3000	Non-RoHS & Green	Call TI	Level-1-260C-UNLIM	-25 to 125	T6B	
LM60BIM3X/NOPB	ACTIVE	SOT-23	DBZ	3	3000	RoHS & Green	SN	Level-1-260C-UNLIM	-25 to 125	T6B	Samples
LM60BIZ/LFT3	ACTIVE	TO-92	LP	3	2000	RoHS & Green	SN	N / A for Pkg Type		LM60 BIZ	Samples
LM60BIZ/NOPB	ACTIVE	TO-92	LP	3	1800	RoHS & Green	Call TI	N / A for Pkg Type	-25 to 125	LM60 BIZ	Samples
LM60CIM3	NRND	SOT-23	DBZ	3	1000	Non-RoHS & Green	Call TI	Level-1-260C-UNLIM	-40 to 125	T6C	
LM60CIM3/NOPB	ACTIVE	SOT-23	DBZ	3	1000	RoHS & Green	SN	Level-1-260C-UNLIM	-40 to 125	T6C	Samples
LM60CIM3X	NRND	SOT-23	DBZ	3	3000	Non-RoHS & Green	Call TI	Level-1-260C-UNLIM	-40 to 125	T6C	
LM60CIM3X/NOPB	ACTIVE	SOT-23	DBZ	3	3000	RoHS & Green	SN	Level-1-260C-UNLIM	-40 to 125	T6C	Samples
LM60CIZ/NOPB	ACTIVE	TO-92	LP	3	1800	RoHS & Green	Call TI	N / A for Pkg Type	-40 to 125	LM60 CIZ	Samples

(1) The marketing status values are defined as follows:

ACTIVE: Product device recommended for new designs.

LIFEBUY: TI has announced that the device will be discontinued, and a lifetime-buy period is in effect.

NRND: Not recommended for new designs. Device is in production to support existing customers, but TI does not recommend using this part in a new design.

PREVIEW: Device has been announced but is not in production. Samples may or may not be available.

OBSELETE: TI has discontinued the production of the device.

(2) **RoHS:** TI defines "RoHS" to mean semiconductor products that are compliant with the current EU RoHS requirements for all 10 RoHS substances, including the requirement that RoHS substance do not exceed 0.1% by weight in homogeneous materials. Where designed to be soldered at high temperatures, "RoHS" products are suitable for use in specified lead-free processes. TI may reference these types of products as "Pb-Free".

RoHS Exempt: TI defines "RoHS Exempt" to mean products that contain lead but are compliant with EU RoHS pursuant to a specific EU RoHS exemption.

Green: TI defines "Green" to mean the content of Chlorine (Cl) and Bromine (Br) based flame retardants meet JS709B low halogen requirements of <=1000ppm threshold. Antimony trioxide based flame retardants must also meet the <=1000ppm threshold requirement.

(3) MSL, Peak Temp. - The Moisture Sensitivity Level rating according to the JEDEC industry standard classifications, and peak solder temperature.

(4) There may be additional marking, which relates to the logo, the lot trace code information, or the environmental category on the device.

(5) Multiple Device Markings will be inside parentheses. Only one Device Marking contained in parentheses and separated by a "~" will appear on a device. If a line is indented then it is a continuation of the previous line and the two combined represent the entire Device Marking for that device.

(6) Lead finish/Ball material - Orderable Devices may have multiple material finish options. Finish options are separated by a vertical ruled line. Lead finish/Ball material values may wrap to two lines if the finish value exceeds the maximum column width.

Important Information and Disclaimer:The information provided on this page represents TI's knowledge and belief as of the date that it is provided. TI bases its knowledge and belief on information provided by third parties, and makes no representation or warranty as to the accuracy of such information. Efforts are underway to better integrate information from third parties. TI has taken and continues to take reasonable steps to provide representative and accurate information but may not have conducted destructive testing or chemical analysis on incoming materials and chemicals. TI and TI suppliers consider certain information to be proprietary, and thus CAS numbers and other limited information may not be available for release.

In no event shall TI's liability arising out of such information exceed the total purchase price of the TI part(s) at issue in this document sold by TI to Customer on an annual basis.

OTHER QUALIFIED VERSIONS OF LM60 :

- Automotive : [LM60-Q1](#)

NOTE: Qualified Version Definitions:

- Automotive - Q100 devices qualified for high-reliability automotive applications targeting zero defects

TAPE AND REEL INFORMATION

QUADRANT ASSIGNMENTS FOR PIN 1 ORIENTATION IN TAPE

*All dimensions are nominal

Device	Package Type	Package Drawing	Pins	SPQ	Reel Diameter (mm)	Reel Width W1 (mm)	A0 (mm)	B0 (mm)	K0 (mm)	P1 (mm)	W (mm)	Pin1 Quadrant
LM60BIM3	SOT-23	DBZ	3	1000	178.0	8.4	3.3	2.9	1.22	4.0	8.0	Q3
LM60BIM3/NOPB	SOT-23	DBZ	3	1000	178.0	8.4	3.3	2.9	1.22	4.0	8.0	Q3
LM60BIM3X	SOT-23	DBZ	3	3000	178.0	8.4	3.3	2.9	1.22	4.0	8.0	Q3
LM60BIM3X/NOPB	SOT-23	DBZ	3	3000	178.0	8.4	3.3	2.9	1.22	4.0	8.0	Q3
LM60CIM3	SOT-23	DBZ	3	1000	178.0	8.4	3.3	2.9	1.22	4.0	8.0	Q3
LM60CIM3/NOPB	SOT-23	DBZ	3	1000	178.0	8.4	3.3	2.9	1.22	4.0	8.0	Q3
LM60CIM3X	SOT-23	DBZ	3	3000	178.0	8.4	3.3	2.9	1.22	4.0	8.0	Q3
LM60CIM3X/NOPB	SOT-23	DBZ	3	3000	178.0	8.4	3.3	2.9	1.22	4.0	8.0	Q3

TAPE AND REEL BOX DIMENSIONS

*All dimensions are nominal

Device	Package Type	Package Drawing	Pins	SPQ	Length (mm)	Width (mm)	Height (mm)
LM60BIM3	SOT-23	DBZ	3	1000	208.0	191.0	35.0
LM60BIM3/NOPB	SOT-23	DBZ	3	1000	208.0	191.0	35.0
LM60BIM3X	SOT-23	DBZ	3	3000	208.0	191.0	35.0
LM60BIM3X/NOPB	SOT-23	DBZ	3	3000	208.0	191.0	35.0
LM60CIM3	SOT-23	DBZ	3	1000	208.0	191.0	35.0
LM60CIM3/NOPB	SOT-23	DBZ	3	1000	208.0	191.0	35.0
LM60CIM3X	SOT-23	DBZ	3	3000	208.0	191.0	35.0
LM60CIM3X/NOPB	SOT-23	DBZ	3	3000	208.0	191.0	35.0

DBZ0003A



PACKAGE OUTLINE

SOT-23 - 1.12 mm max height

SMALL OUTLINE TRANSISTOR

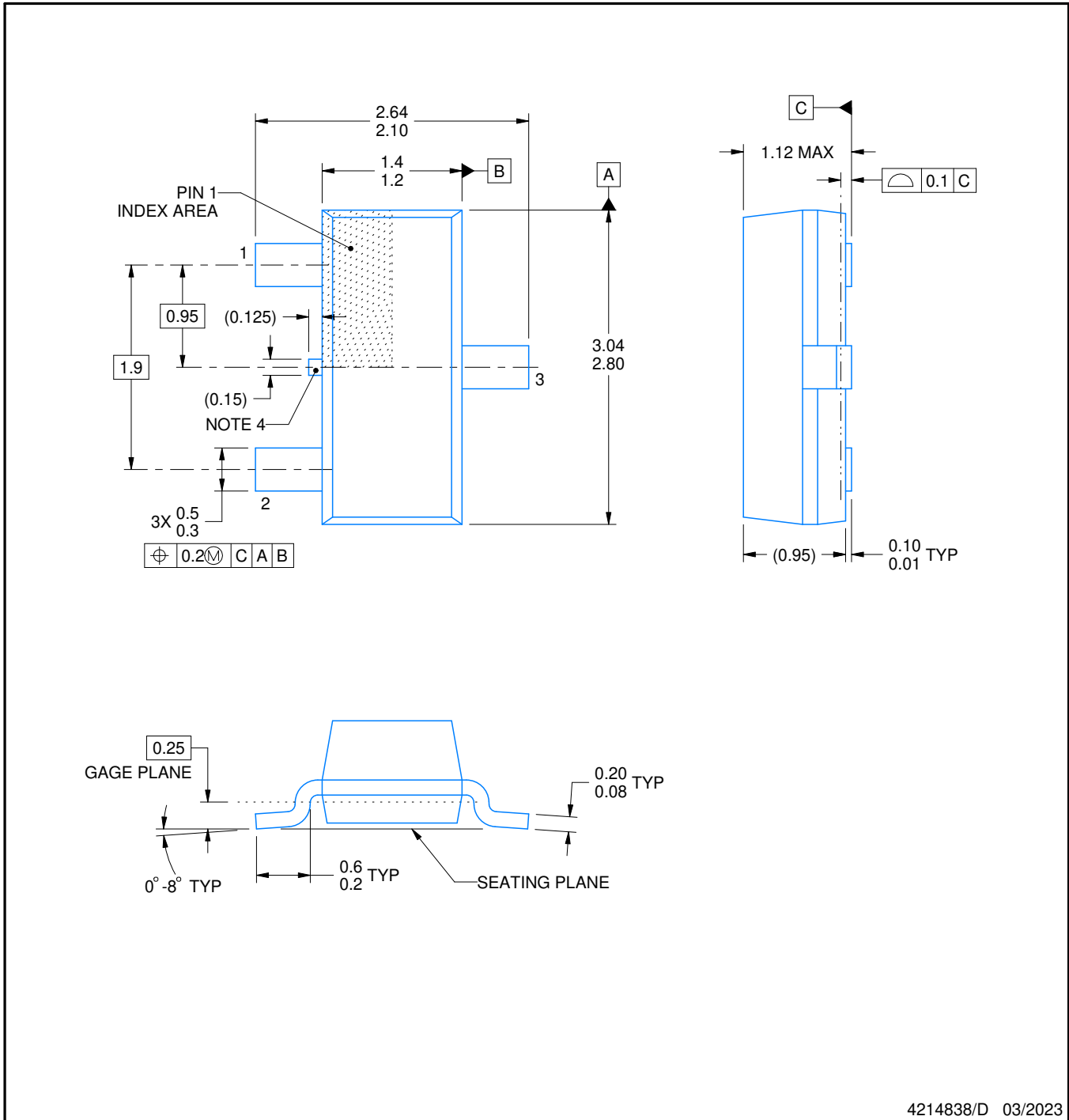

4214838/D 03/2023

NOTES:

1. All linear dimensions are in millimeters. Any dimensions in parenthesis are for reference only. Dimensioning and tolerancing per ASME Y14.5M.
2. This drawing is subject to change without notice.
3. Reference JEDEC registration TO-236, except minimum foot length.
4. Support pin may differ or may not be present.

EXAMPLE BOARD LAYOUT

DBZ0003A

SOT-23 - 1.12 mm max height

SMALL OUTLINE TRANSISTOR

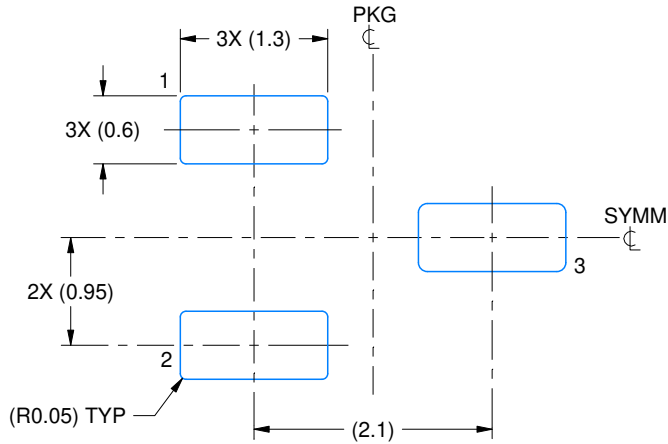

LAND PATTERN EXAMPLE
SCALE:15X

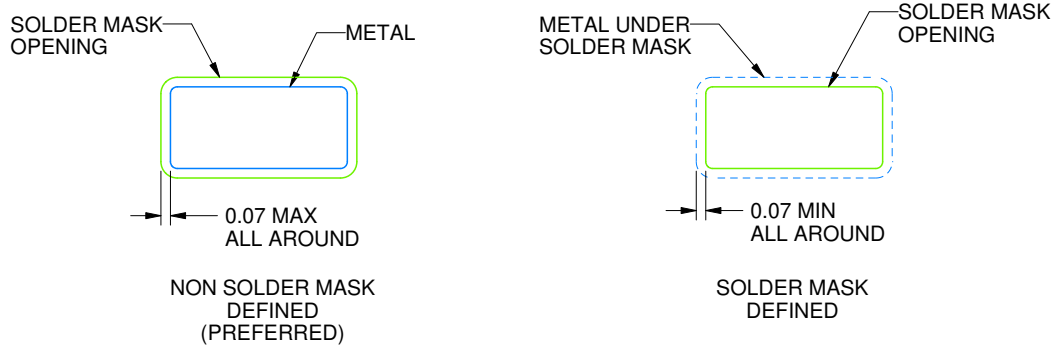

SOLDER MASK DETAILS

4214838/D 03/2023

NOTES: (continued)

4. Publication IPC-7351 may have alternate designs.
5. Solder mask tolerances between and around signal pads can vary based on board fabrication site.

EXAMPLE STENCIL DESIGN

DBZ0003A

SOT-23 - 1.12 mm max height

SMALL OUTLINE TRANSISTOR

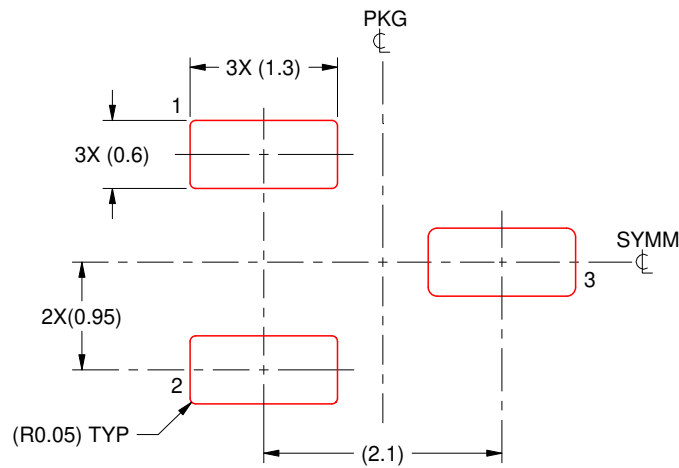

SOLDER PASTE EXAMPLE
BASED ON 0.125 THICK STENCIL
SCALE:15X

4214838/D 03/2023

NOTES: (continued)

6. Laser cutting apertures with trapezoidal walls and rounded corners may offer better paste release. IPC-7525 may have alternate design recommendations.
7. Board assembly site may have different recommendations for stencil design.

GENERIC PACKAGE VIEW

LP 3

TO-92 - 5.34 mm max height

TRANSISTOR OUTLINE



Images above are just a representation of the package family, actual package may vary.
Refer to the product data sheet for package details.

4040001-2/F

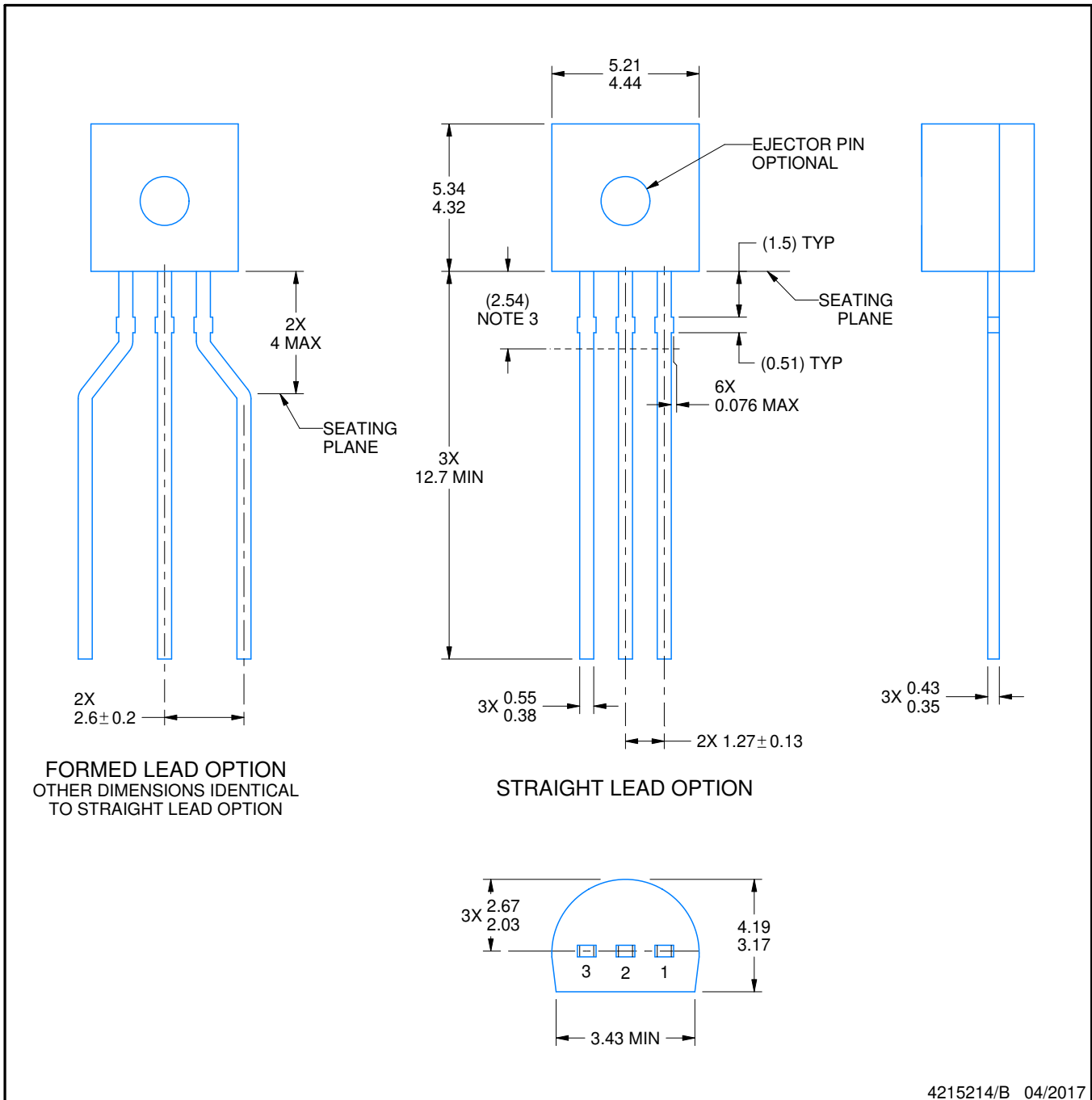

4215214/B 04/2017

NOTES:

1. All linear dimensions are in millimeters. Any dimensions in parenthesis are for reference only. Dimensioning and tolerancing per ASME Y14.5M.
2. This drawing is subject to change without notice.
3. Lead dimensions are not controlled within this area.
4. Reference JEDEC TO-226, variation AA.
5. Shipping method:
 - a. Straight lead option available in bulk pack only.
 - b. Formed lead option available in tape and reel or ammo pack.
 - c. Specific products can be offered in limited combinations of shipping medium and lead options.
 - d. Consult product folder for more information on available options.

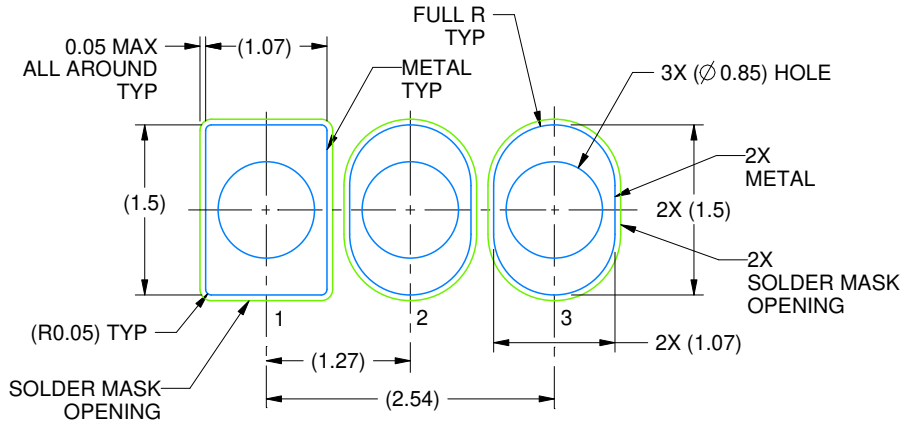

LAND PATTERN EXAMPLE
STRAIGHT LEAD OPTION
NON-SOLDER MASK DEFINED
SCALE:15X

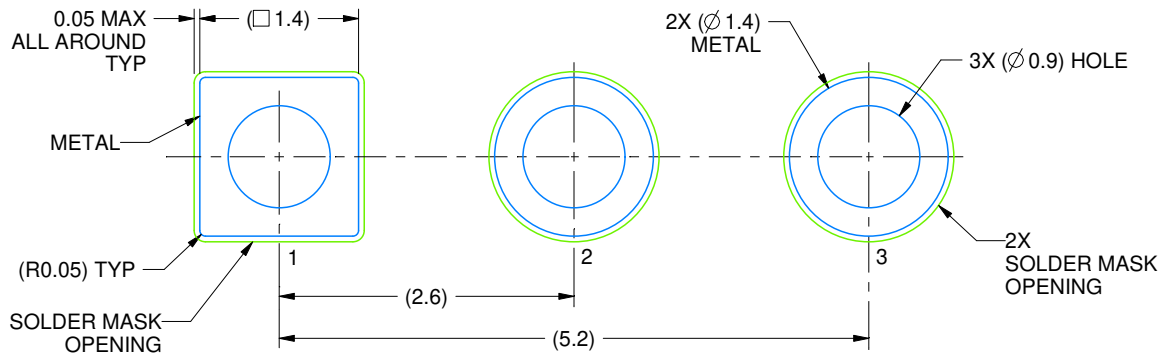

LAND PATTERN EXAMPLE
FORMED LEAD OPTION
NON-SOLDER MASK DEFINED
SCALE:15X

TAPE SPECIFICATIONS

LP0003A

TO-92 - 5.34 mm max height

TO-92

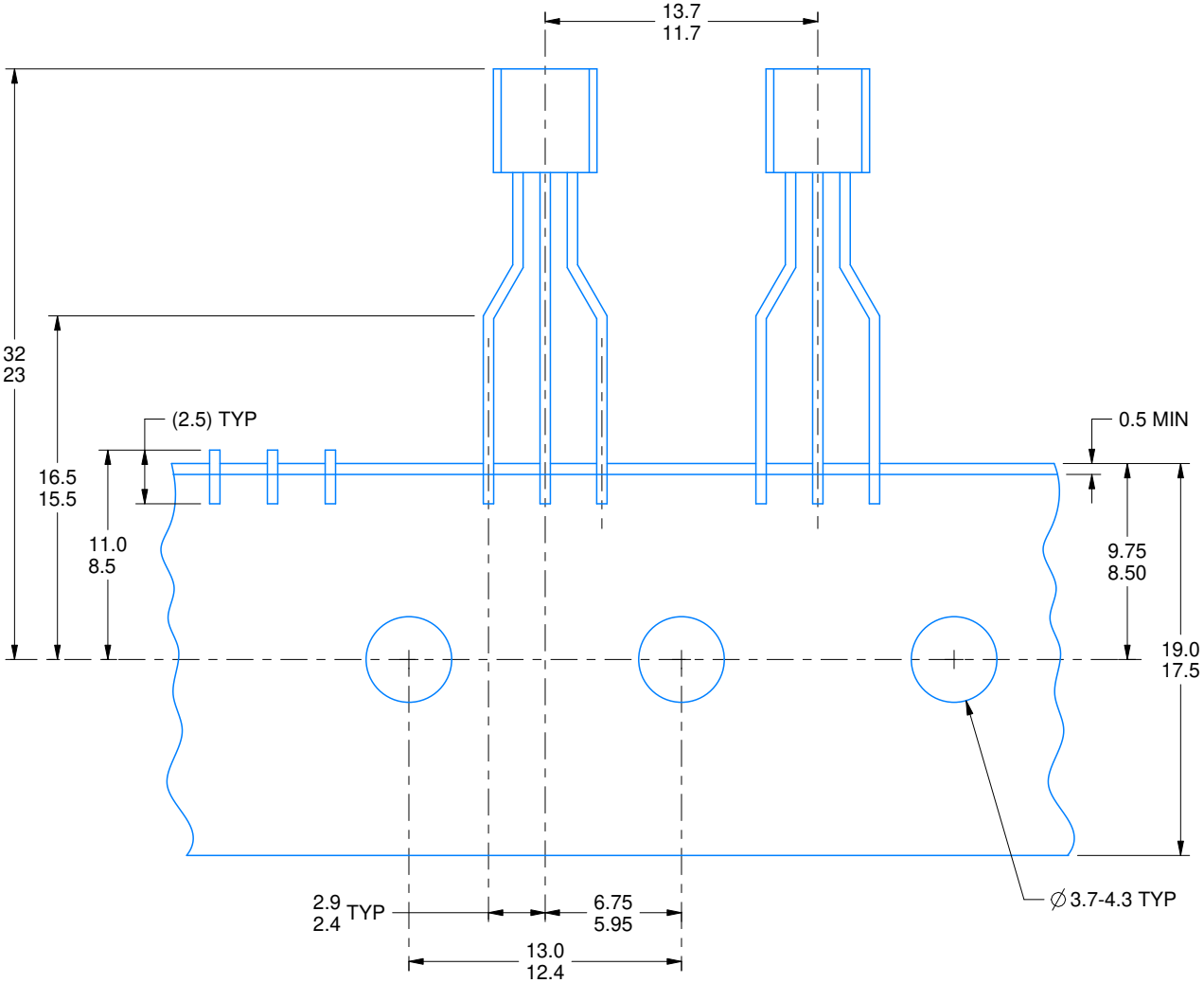

FOR FORMED LEAD OPTION PACKAGE

4215214/B 04/2017

IMPORTANT NOTICE AND DISCLAIMER

TI PROVIDES TECHNICAL AND RELIABILITY DATA (INCLUDING DATA SHEETS), DESIGN RESOURCES (INCLUDING REFERENCE DESIGNS), APPLICATION OR OTHER DESIGN ADVICE, WEB TOOLS, SAFETY INFORMATION, AND OTHER RESOURCES "AS IS" AND WITH ALL FAULTS, AND DISCLAIMS ALL WARRANTIES, EXPRESS AND IMPLIED, INCLUDING WITHOUT LIMITATION ANY IMPLIED WARRANTIES OF MERCHANTABILITY, FITNESS FOR A PARTICULAR PURPOSE OR NON-INFRINGEMENT OF THIRD PARTY INTELLECTUAL PROPERTY RIGHTS.

These resources are intended for skilled developers designing with TI products. You are solely responsible for (1) selecting the appropriate TI products for your application, (2) designing, validating and testing your application, and (3) ensuring your application meets applicable standards, and any other safety, security, regulatory or other requirements.

These resources are subject to change without notice. TI grants you permission to use these resources only for development of an application that uses the TI products described in the resource. Other reproduction and display of these resources is prohibited. No license is granted to any other TI intellectual property right or to any third party intellectual property right. TI disclaims responsibility for, and you will fully indemnify TI and its representatives against, any claims, damages, costs, losses, and liabilities arising out of your use of these resources.

TI's products are provided subject to [TI's Terms of Sale](#) or other applicable terms available either on [ti.com](https://www.ti.com) or provided in conjunction with such TI products. TI's provision of these resources does not expand or otherwise alter TI's applicable warranties or warranty disclaimers for TI products.

TI objects to and rejects any additional or different terms you may have proposed.

Mailing Address: Texas Instruments, Post Office Box 655303, Dallas, Texas 75265
Copyright © 2023, Texas Instruments Incorporated