



MICROCHIP

**PAC1934
Power Meter
User's Guide**

Note the following details of the code protection feature on Microchip devices:

- Microchip products meet the specification contained in their particular Microchip Data Sheet.
- Microchip believes that its family of products is one of the most secure families of its kind on the market today, when used in the intended manner and under normal conditions.
- There are dishonest and possibly illegal methods used to breach the code protection feature. All of these methods, to our knowledge, require using the Microchip products in a manner outside the operating specifications contained in Microchip's Data Sheets. Most likely, the person doing so is engaged in theft of intellectual property.
- Microchip is willing to work with the customer who is concerned about the integrity of their code.
- Neither Microchip nor any other semiconductor manufacturer can guarantee the security of their code. Code protection does not mean that we are guaranteeing the product as "unbreakable."

Code protection is constantly evolving. We at Microchip are committed to continuously improving the code protection features of our products. Attempts to break Microchip's code protection feature may be a violation of the Digital Millennium Copyright Act. If such acts allow unauthorized access to your software or other copyrighted work, you may have a right to sue for relief under that Act.

Information contained in this publication regarding device applications and the like is provided only for your convenience and may be superseded by updates. It is your responsibility to ensure that your application meets with your specifications. MICROCHIP MAKES NO REPRESENTATIONS OR WARRANTIES OF ANY KIND WHETHER EXPRESS OR IMPLIED, WRITTEN OR ORAL, STATUTORY OR OTHERWISE, RELATED TO THE INFORMATION, INCLUDING BUT NOT LIMITED TO ITS CONDITION, QUALITY, PERFORMANCE, MERCHANTABILITY OR FITNESS FOR PURPOSE. Microchip disclaims all liability arising from this information and its use. Use of Microchip devices in life support and/or safety applications is entirely at the buyer's risk, and the buyer agrees to defend, indemnify and hold harmless Microchip from any and all damages, claims, suits, or expenses resulting from such use. No licenses are conveyed, implicitly or otherwise, under any Microchip intellectual property rights unless otherwise stated.

Microchip received ISO/TS-16949:2009 certification for its worldwide headquarters, design and wafer fabrication facilities in Chandler and Tempe, Arizona; Gresham, Oregon and design centers in California and India. The Company's quality system processes and procedures are for its PIC® MCUs and dsPIC® DSCs, KEELOQ® code hopping devices, Serial EEPROMs, microperipherals, nonvolatile memory and analog products. In addition, Microchip's quality system for the design and manufacture of development systems is ISO 9001:2000 certified.

**QUALITY MANAGEMENT SYSTEM
CERTIFIED BY DNV
= ISO/TS 16949 =**

Trademarks

The Microchip name and logo, the Microchip logo, AnyRate, AVR, AVR logo, AVR Freaks, BitCloud, chipKIT, chipKIT logo, CryptoMemory, CryptoRF, dsPIC, FlashFlex, flexPWR, Helder, JukeBlox, KeeLoq, Klear, LANCheck, LINK MD, maXStylus, maXTouch, MediaLB, megaAVR, MOST, MOST logo, MPLAB, OptoLyzer, PIC, picoPower, PICSTART, PIC32 logo, Prochip Designer, QTouch, SAM-BA, SpyNIC, SST, SST Logo, SuperFlash, tinyAVR, UNI/O, and XMEGA are registered trademarks of Microchip Technology Incorporated in the U.S.A. and other countries.

ClockWorks, The Embedded Control Solutions Company, EtherSynch, Hyper Speed Control, HyperLight Load, IntellIMOS, mTouch, Precision Edge, and Quiet-Wire are registered trademarks of Microchip Technology Incorporated in the U.S.A.

Adjacent Key Suppression, AKS, Analog-for-the-Digital Age, Any Capacitor, AnyIn, AnyOut, BodyCom, CodeGuard, CryptoAuthentication, CryptoAutomotive, CryptoCompanion, CryptoController, dsPICDEM, dsPICDEM.net, Dynamic Average Matching, DAM, ECAN, EtherGREEN, In-Circuit Serial Programming, ICSP, INICnet, Inter-Chip Connectivity, JitterBlocker, KlearNet, KlearNet logo, memBrain, Mindi, MiWi, motorBench, MPASM, MPF, MPLAB Certified logo, MPLIB, MPLINK, MultiTRAK, NetDetach, Omniscient Code Generation, PICDEM, PICDEM.net, PICKit, PICtail, PowerSmart, PureSilicon, QMatrix, REAL ICE, Ripple Blocker, SAM-ICE, Serial Quad I/O, SMART-I.S., SQI, SuperSwitcher, SuperSwitcher II, Total Endurance, TSHARC, USBCheck, VariSense, ViewSpan, WiperLock, Wireless DNA, and ZENA are trademarks of Microchip Technology Incorporated in the U.S.A. and other countries.

SQTP is a service mark of Microchip Technology Incorporated in the U.S.A.

Silicon Storage Technology is a registered trademark of Microchip Technology Inc. in other countries.

GestIC is a registered trademark of Microchip Technology Germany II GmbH & Co. KG, a subsidiary of Microchip Technology Inc., in other countries.

All other trademarks mentioned herein are property of their respective companies.

© 2018, Microchip Technology Incorporated, All Rights Reserved.
ISBN: 978-1-5224-3525-9

Table of Contents

Preface	5
Introduction.....	5
Document Layout	5
Conventions Used in this Guide	6
Recommended Reading.....	7
The Microchip Website	7
Product Change Notification Service.....	7
Customer Support	7
Document Revision History	8
 Chapter 1. Product Overview	
1.1 Introduction	9
1.2 PAC1934 Device Overview	9
1.3 PAC1934 Power Meter Overview	9
1.4 PAC1934 Power Meter Kit Contents	10
 Chapter 2. Operation	
2.1 Introduction	11
2.2 Operation Overview	11
2.3 Getting Started	12
2.4 Main Display	13
2.5 Main Display Navigation	14
2.6 Menu Description and Navigation	15
 Chapter 3. System Description	
3.1 Introduction	17
3.2 System parameters and Design considerations	18
3.3 Firmware customization and upgrade	19
 Chapter 4. Hardware Description	
4.1 Hardware Overview	20
4.2 PCB Overview	21
 Appendix A. Schematic and Layouts	
A.1 Introduction	23
A.2 Board – Schematic (USB A)	24
A.3 Board – Top Silk Layer (USB A)	25
A.4 Board – Top Copper and Silk Layer (USB A)	25
A.5 Board – Top Copper Layer (USB A)	26
A.6 Board – Inner 1 Layer (USB A)	26

A.7 Board – Inner 2 Layer (USB A)	27
A.8 Board – Bottom Copper Layer (USB A)	27
A.9 Board – Bottom Copper and Silk Layer (USB A)	28
A.10 Board – Bottom Silk Layer (USB A)	28
A.11 Board – Schematic (USB C) 1	29
A.12 Board – Schematic (USB C) 2	30
A.13 Board – Schematic (USB C) 3	31
A.14 Board – Top Silk Layer (USB C)	32
A.15 Board – Top Copper and Silk Layer (USB C)	32
A.16 Board – Top Copper Layer (USB C)	33
A.17 Board – Bottom Copper Layer (USB C)	33
A.18 Board – Bottom Copper and Silk Layer (USB C)	34
A.19 Board – Bottom Silk Layer (USB C)	34
Appendix B. Bill of Materials (BOM)	
Worldwide Sales and Service	39

Preface

NOTICE TO CUSTOMERS

All documentation becomes dated, and this manual is no exception. Microchip tools and documentation are constantly evolving to meet customer needs, so some actual dialogs and/or tool descriptions may differ from those in this document. Please refer to our website (www.microchip.com) to obtain the latest documentation available.

Documents are identified with a “DS” number. This number is located on the bottom of each page, in front of the page number. The numbering convention for the DS number is “DSXXXXXXXXA”, where “XXXXXXXX” is the document number and “A” is the revision level of the document.

For the most up-to-date information on development tools, see the MPLAB® IDE online help. Select the Help menu, and then Topics, to open a list of available online help files.

INTRODUCTION

This chapter contains general information that will be useful to know before using the PAC1934 Power Meter. Items discussed in this chapter include:

- [Document Layout](#)
- [Conventions Used in this Guide](#)
- [Warranty Registration](#)
- [Recommended Reading](#)
- [The Microchip Website](#)
- [Customer Support](#)
- [Document Revision History](#)

DOCUMENT LAYOUT

This document describes how to use the PAC1934 Power Meter. The manual layout is as follows:

- **Chapter 1. “Product Overview”** – Important information about the PAC1934 Power Meter.
- **Chapter 2. “Operation”** – This chapter includes a detailed description of each function of the demonstration board and instructions for how to begin using the PAC1934 Power Meter.
- **Chapter 3. “System Description”** – This chapter describes the overall system architecture and parameters used by the power meter.
- **Chapter 4. “Hardware Description”** – This chapter offers details on the hardware of the power meter, describing each block of the PCB assembly.
- **Appendix A. “Schematic and Layouts”** – Shows the schematic and PCB layout diagrams for the PAC1934 Power Meter.
- **Appendix B. “Bill of Materials (BOM)”** – Lists the parts used to build the PAC1934 Power Meter.

CONVENTIONS USED IN THIS GUIDE

This manual uses the following documentation conventions:

DOCUMENTATION CONVENTIONS

Description	Represents	Examples
Arial font:		
Italic characters	Referenced books	<i>MPLAB® IDE User's Guide</i>
	Emphasized text	...is the <i>only</i> compiler...
Initial caps	A window	the Output window
	A dialog	the Settings dialog
	A menu selection	select Enable Programmer
Quotes	A field name in a window or dialog	"Save project before build"
Underlined, italic text with right angle bracket	A menu path	<u><i>File>Save</i></u>
Bold characters	A dialog button	Click OK
	A tab	Click the Power tab
N'Rnnnn	A number in verilog format, where N is the total number of digits, R is the radix and n is a digit.	4'b0010, 2'hF1
Text in angle brackets < >	A key on the keyboard	Press <Enter>, <F1>
Courier New font:		
Plain Courier New	Sample source code	#define START
	Filenames	autoexec.bat
	File paths	c:\mcc18\h
	Keywords	_asm, _endasm, static
	Command-line options	-Opa+, -Opa-
	Bit values	0, 1
	Constants	0xFF, 'A'
Italic Courier New	A variable argument	<i>file.o</i> , where <i>file</i> can be any valid filename
Square brackets []	Optional arguments	mcc18 [options] <i>file</i> [options]
Curly brackets and pipe character: { }	Choice of mutually exclusive arguments; an OR selection	errorlevel {0 1}
Ellipses...	Replaces repeated text	var_name [, var_name...]
	Represents code supplied by user	void main (void) { ... }

RECOMMENDED READING

This user's guide describes how to use the PAC1934 Power Meter. Other useful documents are listed below. The following Microchip documents are available and recommended as a supplemental reference resource:

- **PAC1934 Data Sheet – “Multi-Channel DC Power/Energy Monitor with Accumulator” (DS20005850)**

This data sheet provides detailed information regarding the PAC1934 device.

- **PIC24FJ128GA702 Family Data Sheet – “16-Bit General Purpose Microcontrollers with 256-Kbyte Flash and 16-Kbyte RAM in Low Pin Count Packages” (DS30010118)**

This data sheet provides detailed information regarding the PIC24FJ128GA702 device.

THE MICROCHIP WEBSITE

Microchip provides online support via our website at www.microchip.com. This website is used as a means to make files and information easily available to customers. Accessible by using your favorite Internet browser, the website contains the following information:

- **Product Support** – Data sheets and errata, application notes and sample programs, design resources, user's guides and hardware support documents, latest software releases and archived software
- **General Technical Support** – Frequently Asked Questions (FAQs), technical support requests, online discussion groups, Microchip consultant program member listing
- **Business of Microchip** – Product selector and ordering guides, latest Microchip press releases, listing of seminars and events, listings of Microchip sales offices, distributors and factory representatives

PRODUCT CHANGE NOTIFICATION SERVICE

Microchip's customer notification service helps keep customers current on Microchip products. Subscribers will receive e-mail notifications whenever there are changes, updates, revisions or errata related to a specified product family or development tool of interest.

To register, access the Microchip website at www.microchip.com, click on **Product Change Notification** and follow the registration instructions.

CUSTOMER SUPPORT

Users of Microchip products can receive assistance through several channels:

- Distributor or Representative
- Local Sales Office
- Field Application Engineer (FAE)
- Technical Support

Customers should contact their distributor, representative or field application engineer (FAE) for support. Local sales offices are also available to help customers. A listing of sales offices and locations is included in the back of this document.

Technical support is available through the website at:
<http://www.microchip.com/support>.

DOCUMENT REVISION HISTORY

Revision A (September 2018)

- Initial Release of this Document.

Chapter 1. Product Overview

1.1 INTRODUCTION

This chapter provides an overview of the PAC1934 Power Meter.

1.2 PAC1934 DEVICE OVERVIEW

The PAC1934 are four-channel power and energy monitoring devices. A high-voltage multiplexer sequentially connects the inputs to a bus voltage monitor and current sense amplifier that feed high-resolution ADCs. Digital circuitry performs power calculations and energy accumulation. This enables energy monitoring with integration periods from 1 ms up to 36 hours or longer. Bus voltage, sense resistor voltage and accumulated proportional power are stored in registers for retrieval by the system master or by the embedded controller. The sampling rate and energy integration period can be controlled over SMBus or I²C. Active channel selection, one-shot measurements and other controls are also configurable by SMBus or I²C. The PAC1934 device uses real-time calibration to minimize offset and gain errors. No input filters are required for this device.

1.3 PAC1934 POWER METER OVERVIEW

The PAC1934 Power Meter is a high-performance, low-power consumption energy monitor designed for devices powered by USB Type C or Type A ports. The PAC1934 Power Meter is designed as a USB dongle device, with a plug at one end and receptacle at the other. The USB-C variant can also demonstrate the bidirectional current measurement capability of the PAC1934 on the extended Type-C V_{BUS} range.

The PAC1934 Power Meter is a ready-to-use device that provides the possibility of future firmware updates.



FIGURE 1-1: PAC1934 Power Meter.

1.4 PAC1934 POWER METER KIT CONTENTS

The PAC1934 Power Meter kit includes:

- PAC1934 Power Meter
- Important Information Sheet

Chapter 2. Operation

2.1 INTRODUCTION

This section describes how to use the PAC1934 Power Meter and covers the following topics:

- [Operation Overview](#)
- [Getting Started](#)
- [Main Display](#)
- [Main Display Navigation](#)
- [Menu Description and Navigation](#)

2.2 OPERATION OVERVIEW

The PAC1934 Power Meter is a simple, easy to use and intuitive device. It has only one multifunctional switch that can be used for display navigation and menu option selection (by rotating to left/right and center push). Once connected the device starts working automatically displaying several measured values: USB power line voltage, amperage, energy, charge, and lapsed time. The user can easily choose to display a particular main display component at a larger scale simply by rotating the multifunctional switch. There are four working states: Data mode (default), Configuration mode, Screen saver and Message box.

The Data mode has several data display pages selectable by scroll buttons. Configuration mode has several configuration pages selectable by scroll buttons. Some configuration pages have additional configuration parameter sub-pages, activated by the Enter action on the selected configuration page. Inside the configuration parameter pages the scroll buttons let the user select or set the desired parameter value. The center switch action completes the Configuration mode, returning the device in Data mode.

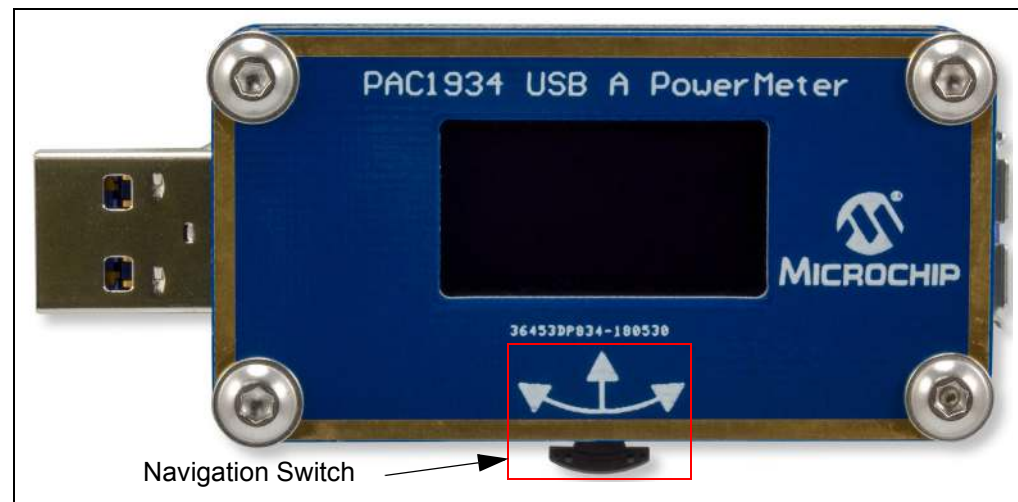

FIGURE 2-1: Navigation Switch.

2.3 GETTING STARTED

The PAC1934 Power Meter starts once it is plugged into an active USB port (it can be a PC, a power bank or any other device with USB interface that also provides power to the connected devices). The design of the PAC1934 Power Meter allows it to be connected in both ways, so it is compatible with the **Plug** end as well as with the **Receptacle** end of the connected device and it can monitor the power in both directions of the current flow.

The plug end of the device is marked as IN and the receptacle end is marked as OUT on the device bottom shield. The PAC1934 Power Meter's own power is drawn from the IN end, before the current sense resistor. Therefore, if the OUT end is the power receiving port, the device adds its own energy consumption to the measurements.

After connecting the power meter to the master device, for a very short period of time (0.5 seconds), the message "PAC1934 by MICROCHIP" and the firmware version is displayed on the screen (the firmware version can be checked anytime in the special menu section). The measurements start once the PAC1934 device is configured. The splash screen is displayed after configuration completion. Therefore, the energy is accumulated also during the 0.5 seconds of splash screen. On the screen, the user can see the main display with the associated components (for more details see [Section 2.4 "Main Display"](#)).

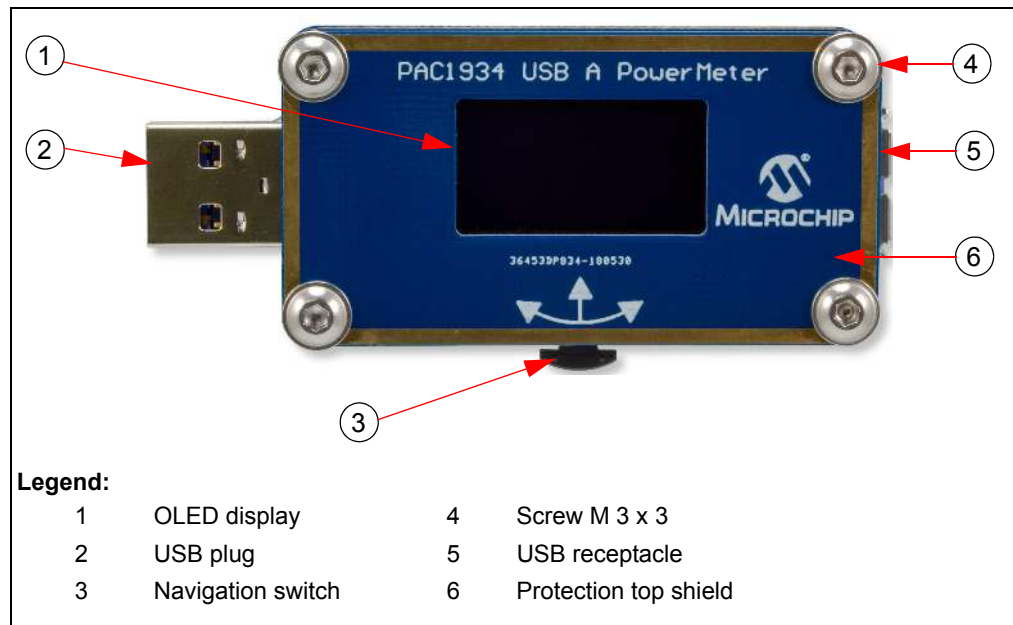

FIGURE 2-2: PAC1934 Power Meter.

As shown in [Figure 2-2](#), the device has four main components: USB-IN, USB-OUT, the Navigation Switch and the OLED. The USB-A plug and receptacle are shown. A USB-C version is also available.

2.4 MAIN DISPLAY

After start-up the device works in Data mode: all data related to the power measurement and other computed components such as elapsed time, power and energy accumulation can be visualized directly on the OLED screen. In Data mode, navigation (to the left and to the right) allows to selectively view each element of the main screen on a larger scale.

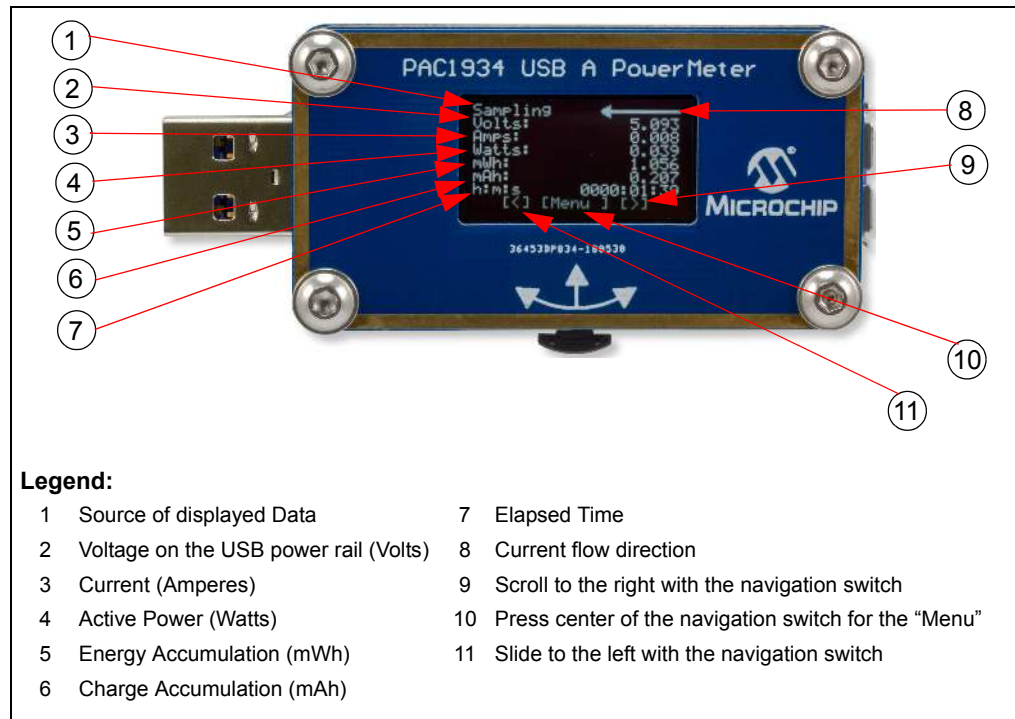

FIGURE 2-3: Main Display.

As shown in [Figure 2-3](#), the display bottom line is a context aware navigation helper, indicating what action is associated with a certain navigation switch position: scrolling left/right, value increase/decrease, selection in/out or confirmation.

Above the navigation helper line, the main display contains seven information text lines, which show information related to measurement and display USB power rail parameters as well as other computed parameters such as battery charge/discharge and elapsed time.

The display top line is the status line, showing whether the data on display is real-time or logged data and, the current flow direction:

- Sampling: real-time data is displayed
- Log#: xy: logged data is displayed (from the memory slot number xy. Note that the PAC1934 device continues the data sampling process at the same time. So, no energy data is lost while log memory is on display.
- The current flow arrow can indicate left and right directions or can turn into an interrupted line when no current flow is detected (0 Amps).

To visualize real-time data samples from the PAC1934, the menu path below can be followed:

menu>Data Source>PAC1934>Enter or
menu>Resume from Log>PAC1934>Enter

The informational text lines on the main display are structured as follows:

- **Volts:** the voltage on the power rail (Voltage)
- **Amps:** the electric current intensity (Current)
- **Watts:** calculated power (mW)
- **mWh:** energy accumulation/draining
- **mAh:** charge accumulation/drain expressed as charge/discharge value
- **h.m.s:** elapsed time since data sampling started (the device powered-up or counters reset)

2.5 MAIN DISPLAY NAVIGATION

In Data mode the user can select the system menu by pressing the navigation switch or can navigate through the displayed data elements by turning the navigation switch to the left or to the right. The whole main display menu is illustrated in [Figure 2-4](#), the elements shown are a zoom-in version of the text lines from the main display. On the USB-C Power Meter there is an additional data screen, displaying the voltage on CC1 and CC2 pins.

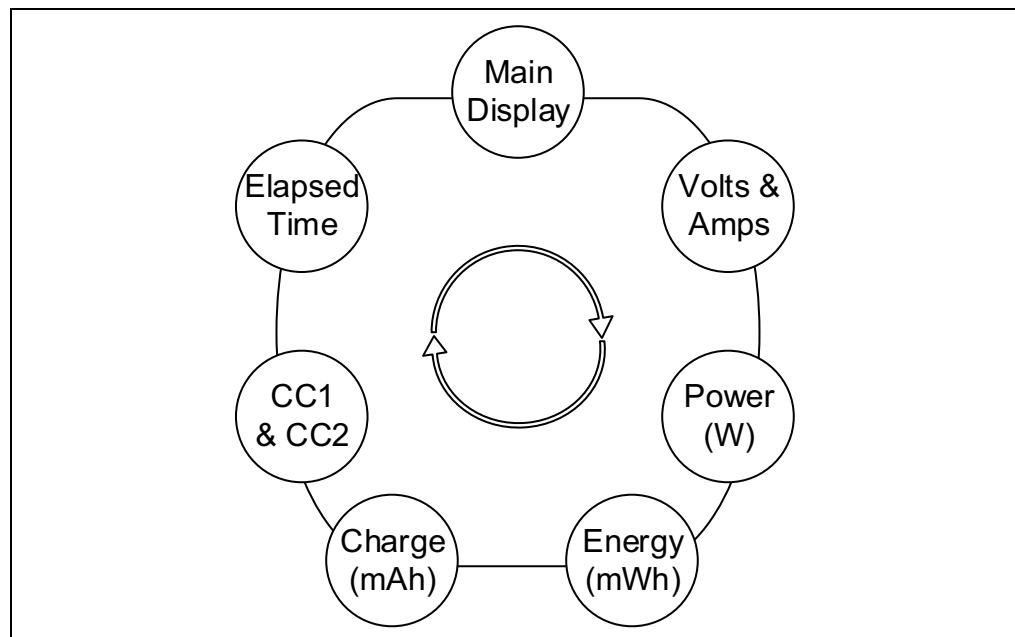

FIGURE 2-4: Main Display Navigation Chart.

2.6 MENU DESCRIPTION AND NAVIGATION

The selection of the system menu can be done by pressing the navigation switch. After entering the menu display, the user can navigate through the menu options by turning the switch left and right, as indicated by the symbols (<) and (>). The menu elements can be selected by pressing the navigation switch.

The structure and content of the system menu is shown in [Figure 2-5](#).

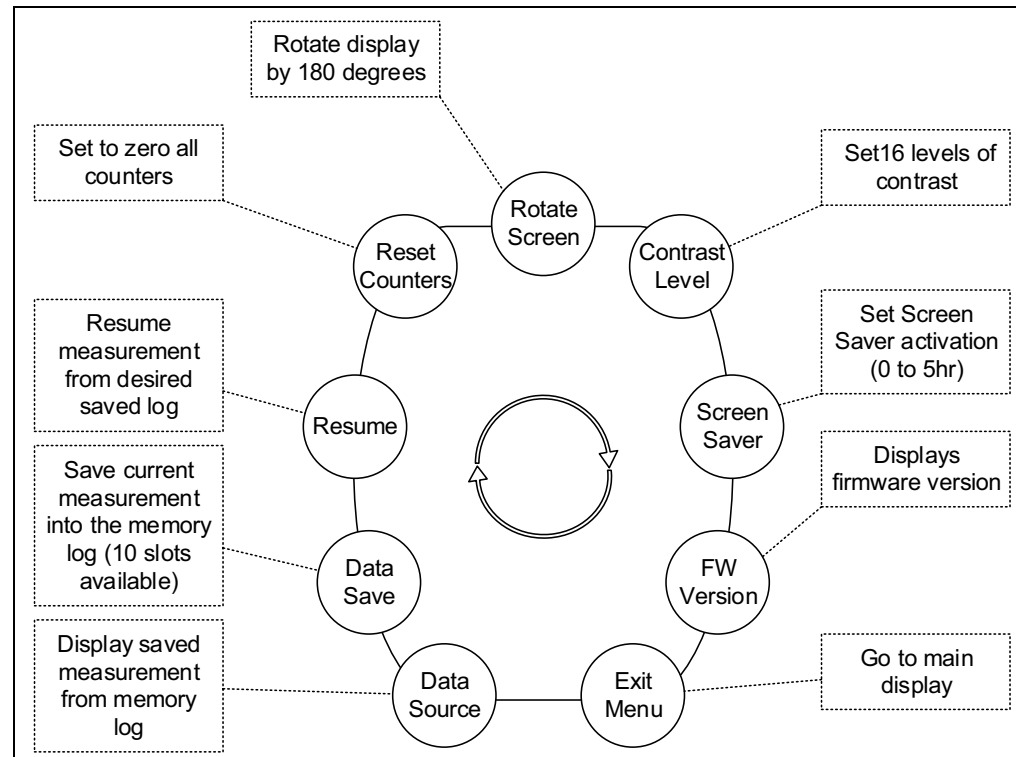

FIGURE 2-5: Menu Navigation Chart.

As shown in the menu structure chart, there are nine positions that can be selected to access desired function, as follows:

- **Rotate Screen:** this function rotates the displayed text on screen by 180 degrees and it allows to read information from the display even when the device is connected upside down. The screen remains rotated until the Rotate Screen from the menu is selected again or the device is restarted. By default, the screen is orientated in the same direction as the inscriptions on the Printed Circuit Board (PCB) case. In order to facilitate the screen orientation selection, this function is the first one in the menu list.
- **Contrast Level:** contains 16 selectable levels of OLED contrast. Increasing the level allows better screen visualization and decreasing it reduces the power loss/consumption, as desired.
- **Screen Saver:** this function reduces the power consumption of the device by collapsing the process of displaying information on the screen as well as interrupting the communication between MCU and OLED. While the Screen Saver mode is active, only the display text line can be seen at the bottom of the screen, this means that the device is powered on and the power metering process is not stopped. To exit Screen Saver mode, press or rotate the navigation switch in any direction.

- **Firmware Version:** displays the current version of the software. The firmware version string format is A.x.y for USB type A devices and C.x.y for USB type C devices, where x is the revision major number and y is the revision minor number.
- **Exit Menu:** used to return to the main display and exit menu.
- **Data Source:** allows the user to visualize up to 10 data records (previously saved) as well as the real-time measurements of the PAC1934. When trying to display an empty memory slot, the `Empty Log. Ignored.` message will be displayed. Another important thing to remember is that the visualization of previously saved data does not interrupt the measurement process of the power line. The real-time measurement process continues to run in the background and can be visualized again by selecting the PAC1934 as data source:
*menu>Data Source>PAC1934>Enter or
menu>Resume from Log>PAC1934>Enter*
- **Data Save:** is used to save current, real-time measurements into a memory slot called Log#: There are ten available memory slots for data saving. Every new data save process will automatically overwrite the old data stored on the selected memory slot. In case the user is no longer interested in using the Data Save function or it was accessed by mistake, the Cancel function aborts the logging process and exits the Data Save menu.
- **Resume from Log:** facilitates the possibility to resume the energy measurement from a moment previously saved in a memory slot. When the message `Empty Log. Ignored.` appears, it means that the particular memory slot has no recorded information. A recorded measurement can be resumed anytime because the data records remain resident in the memory even when the device is powered off.
- **Reset Counters:** clears the real-time data measurement that is in progress, resetting to zero all computed counters including the elapsed time indicator. After selecting Reset Counters, the main display will automatically return to the last selected data display page and the system restarts automatically the counter updating process.

Chapter 3. System Description

3.1 INTRODUCTION

The PAC1934 Power Meter's internal logical structure is presented in [Figure 3-1](#) and [Figure 3-2](#). As shown in the figures, there are three main components which communicate with each other using the I²C communications protocol. The PAC1934 and the OLED display represent the slaves, the PIC24 microcontroller represents the master and they all share the same bus.

The Navigation Switch is essentially a three-button assembly, each button being connected to a separate PIC24 I/O pin.

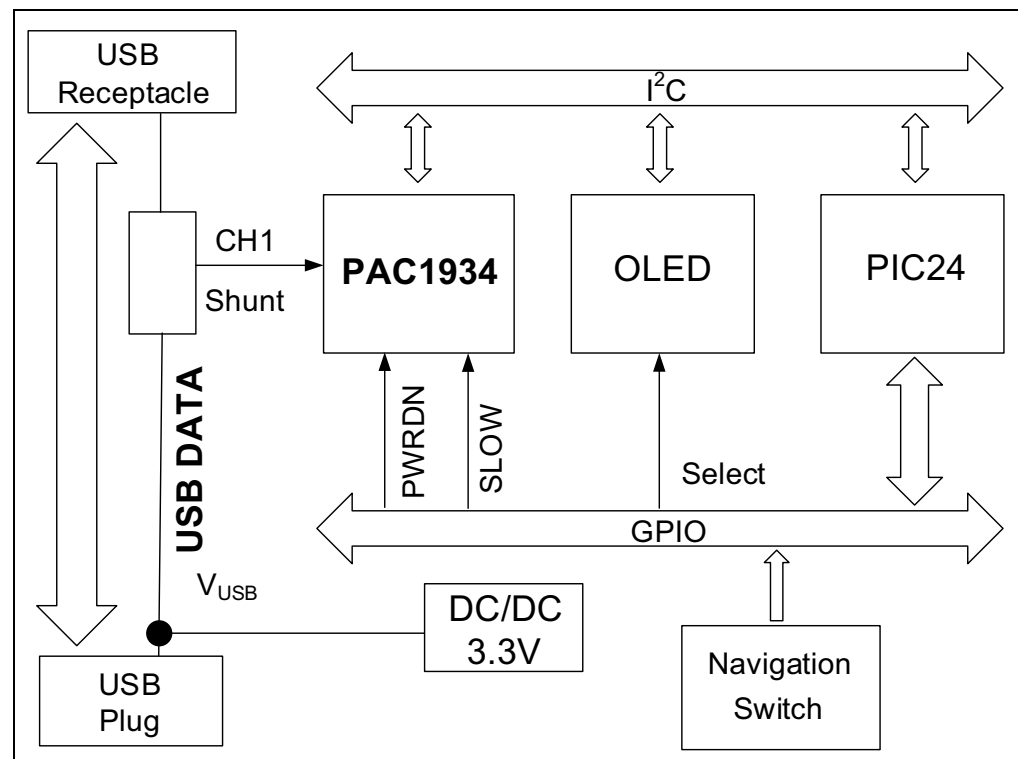

FIGURE 3-1: Block Diagram PAC1934 USB-A.

3.2 SYSTEM PARAMETERS AND DESIGN CONSIDERATIONS

The PAC1934 Power Meter can be used to measure the USB power rail at a range of 3.3 - 20V_{CC}, with V_{SENSE} accuracy up to ±0.02 mV @ 25°C. USB Type-A power rail must be 5V but USB Type-C power may have any value between 5V to 20V.

When there is no power consumer (I_{SENSE} = 0), V_{SENSE} accuracy may create false non-zero V_{SENSE} readings. Consequently, a very small but non-zero value may be reported by power-product accumulator. To overcome this false energy accumulation, the device validates it by comparing the average power computed for the last data reporting period against a NO LOAD power threshold, computed as a function of V_{SENSE} accuracy, sense resistor value and USB power voltage.

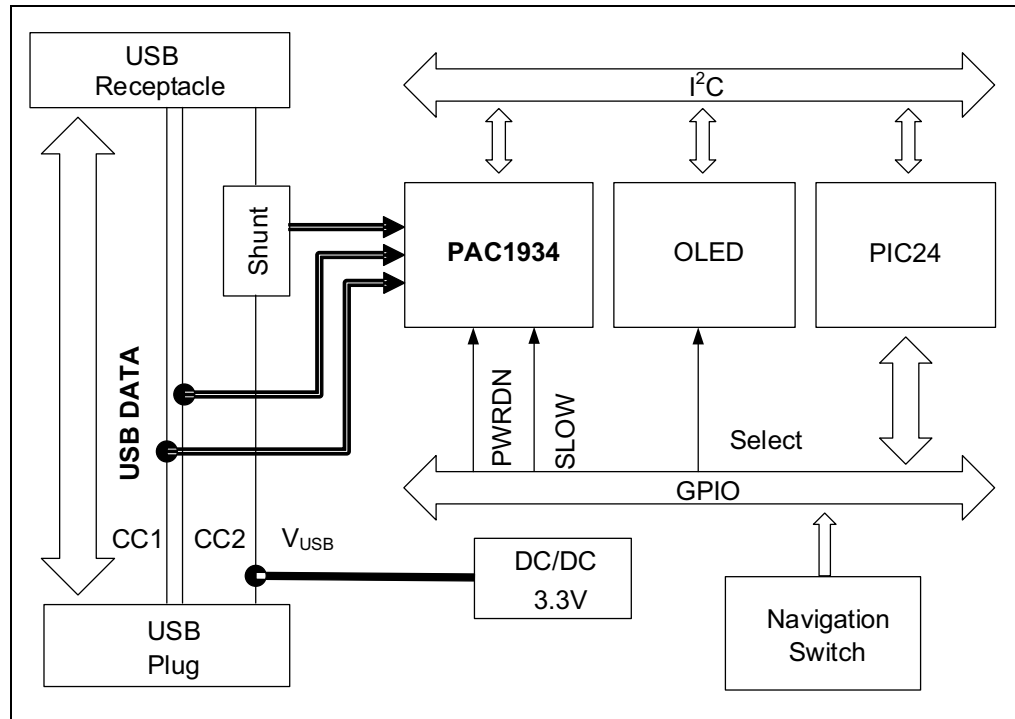

FIGURE 3-2: Block Diagram PAC1934 USB-C.

The PAC1934 Power Meter is designed as a very low power device, so USB-C requires 40 mW at 5 V_{CC}. The PAC1934 USB-C Power Meter consumes only 8 mA, because 90% of the time the processor is in Idle state.

The Screen Saver mode reduces the OLED contrast to a minimum and the display data refresh is suspended, increasing the processor idle time to 98%, thus reducing the power consumption to about 60%.

There is an important aspect to take into consideration when connecting the Power Meter to the power source: as shown in the block diagram, the shunt resistor is placed between the USB Receptacle and the DC/DC 3.3V Power Adapter, so depending on what connector is plugged to the power source, the device can measure its own power consumption. When the device is connected to a power source through the USB receptacle, with no other power load at the other end, the user can see the amount of current consumed internally by the Power Meter. In reversed connection (the USB power source is connected to the USB plug and no load at the other end), no current flow will be displayed because the shunt resistance is positioned after the power supply block of the device.

3.3 FIRMWARE CUSTOMIZATION AND UPGRADE

The device firmware source code and project files are available for the user to download from the product website and modify as needed. The document “*PAC1934 USB Power Meter Firmware Manual*” included in the source code bundle provides relevant details about the code structure, firmware build and deployment instructions. Please note that additional software and hardware are needed in order to build the project and deploy the firmware:

- MPLAB X IDE (v4.20 or later)
- MPLAB ICD3 (or later) In-Circuit debugger
- TAG-connect cable

Chapter 4. Hardware Description

4.1 HARDWARE OVERVIEW

The PAC1934 Power Meter is designed as a simple to use and robust device. The hardware structure consists of a multiple PCB layered sandwich, without plastic case, as a reliable and flexible approach. It is very easy to disassemble the Power Meter. Just a couple basic tools are needed to get access to the Tag-Connect pads (www.tag-connect.com) for the programming tool (ICD3 or newer).

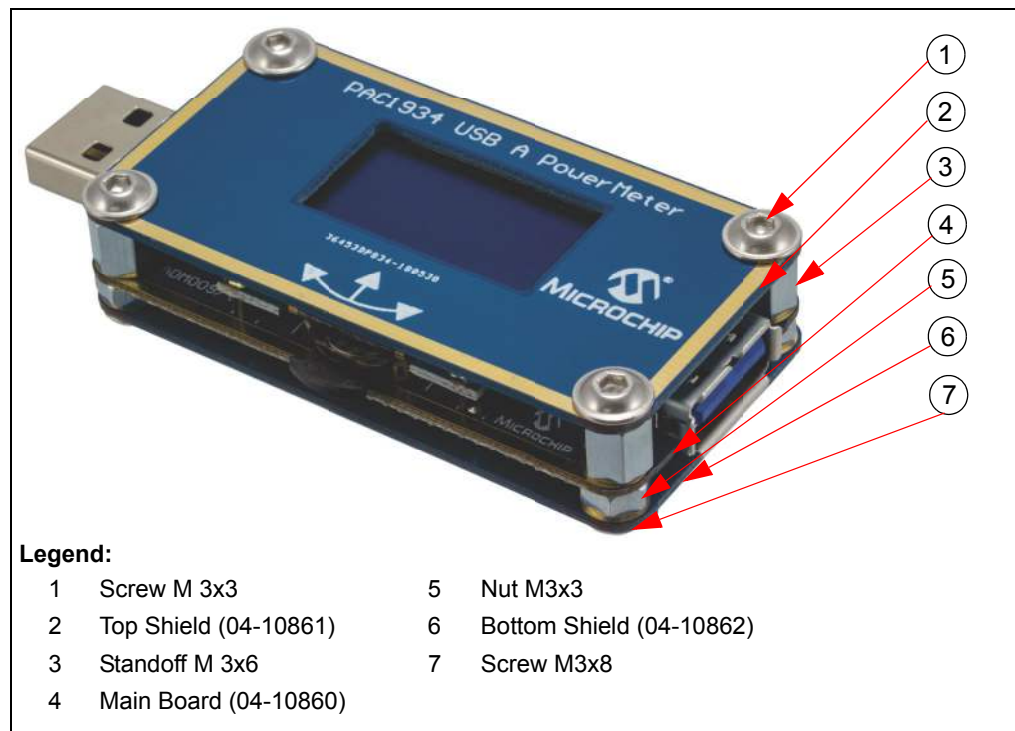

FIGURE 4-1: PAC1934 Power Meter Assembly.

Hardware Description

For a proper device assembly, make sure that the device component layers are overlaid exactly as shown in Figure 4-2. The bottom shield (the one with the schematic representation of the internal structure of the system) has to be mounted with caution at the matching IN with USB plug and OUT with USB receptacle.

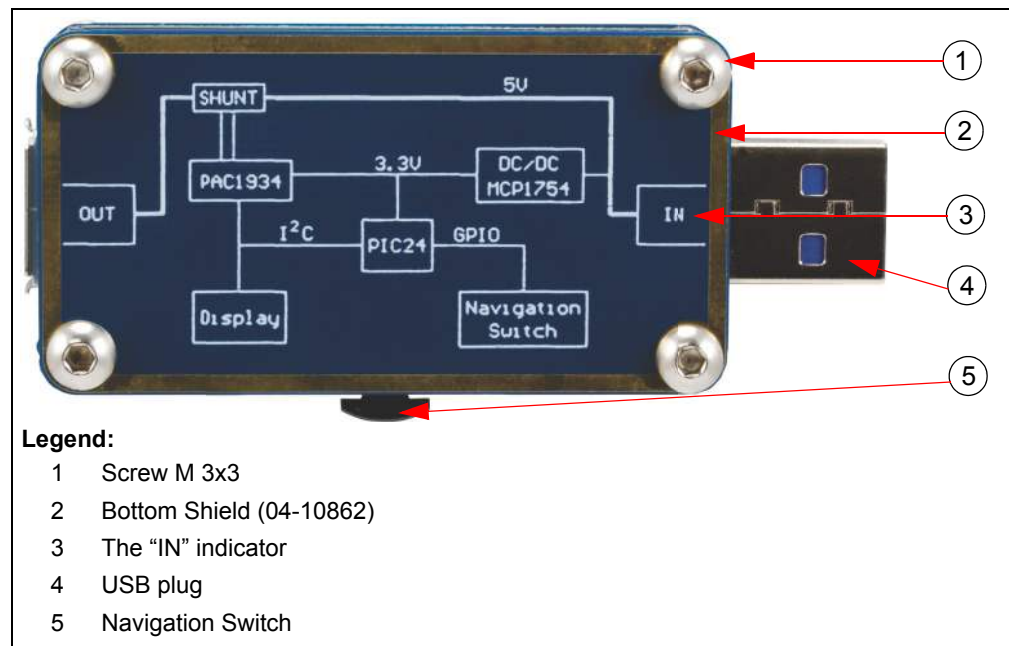

FIGURE 4-2: PAC1934 USB Power Meter Bottom Shield.

4.2 PCB OVERVIEW

The PAC1934 Power Meter is composed of three PCB layers. The top layer as well as the bottom layer are designed as a protection shield. Only the middle PCB layer is hosting all the electronic components. The bottom PCB layer has a schematic representation of the internal connections, drawn on its external side, to help the user to understand the internal structure and the functionality of the device.

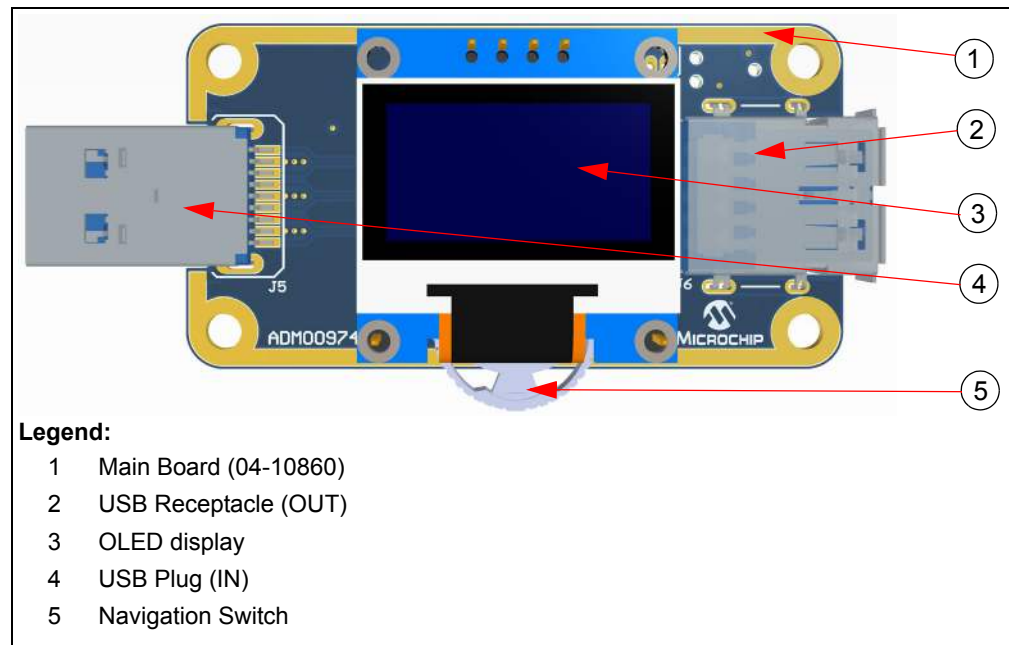

FIGURE 4-3: Top View – Main PCB.

Hardware Description

The main PCB board is the central PCB in the layered structure of the device, this PCB is populated on the top as well as on the bottom, to minimize space usage and to reduce the final dimensions of the PCB.

The main board (Figure 4-3) shows the following set-up:

- On the upper side, from left to right, is the location of the USB plug connection.
- In the center, upper side, there is a 128 x 64 I²C white OLED ICD display module.
- In the central position, right under the OLED, is the 1 mA MCPL3-AC-V SMD R/A navigation switch.
- The USB receptacle connector is the last component on the right side of the board.

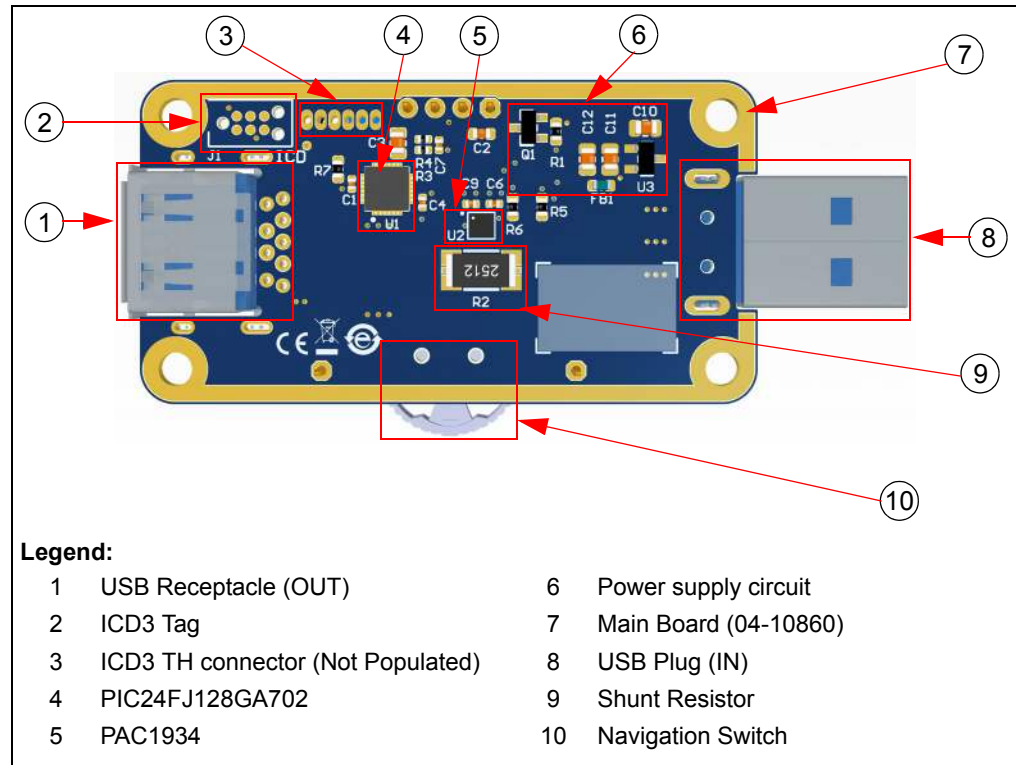

FIGURE 4-4: Bottom View – Main PCB.

On the upper-left side is shown the non-isolated ICD3 Tag programming connector header as well as the ICD TH connection socket that comes with a non-populated TH connector that can be an alternative programming connection (for use with PICKit™ programmer for instance).

On the upper-right side of the USB-C is the power circuit with an LDO and a switcher, used to power-up all the system's electronic components with constant 3.3V voltage. On the USB-A system the power circuit was simplified using only the LDO.

On the central side of the board are the main components of the device as follows:

- PIC24FJ128GA702 16-bit microcontroller featuring 128 kB of ECC Flash, 16 kB of RAM and eXtreme Low Power.
- The PAC1934, four-channel DC Power/Energy Monitor with accumulator
- On the bottom is the shunt resistor.

For more details see [Appendix A. “Schematic and Layouts”](#) and [Appendix B. “Bill of Materials \(BOM\)”](#).

Appendix A. Schematic and Layouts

A.1 INTRODUCTION

This appendix contains the following schematics and layouts for the PAC1934 Power Meter.

PAC1934 Power Meter USB A

- [Board – Schematic \(USB A\)](#)
- [Board – Top Silk Layer \(USB A\)](#)
- [Board – Top Copper and Silk Layer \(USB A\)](#)
- [Board – Top Copper Layer \(USB A\)](#)
- [Board – Inner 1 Layer \(USB A\)](#)
- [Board – Inner 2 Layer \(USB A\)](#)
- [Board – Bottom Copper Layer \(USB A\)](#)
- [Board – Bottom Copper and Silk Layer \(USB A\)](#)
- [Board – Bottom Silk Layer \(USB A\)](#)

PAC1934 Power Meter USB C

- [Board – Schematic \(USB C\) 1](#)
- [Board – Schematic \(USB C\) 2](#)
- [Board – Schematic \(USB C\) 3](#)
- [Board – Top Silk Layer \(USB C\)](#)
- [Board – Top Copper and Silk Layer \(USB C\)](#)
- [Board – Top Copper Layer \(USB C\)](#)
- [Board – Bottom Copper Layer \(USB C\)](#)
- [Board – Bottom Copper and Silk Layer \(USB C\)](#)
- [Board – Bottom Silk Layer \(USB C\)](#)

A.2 BOARD – SCHEMATIC (USB A)

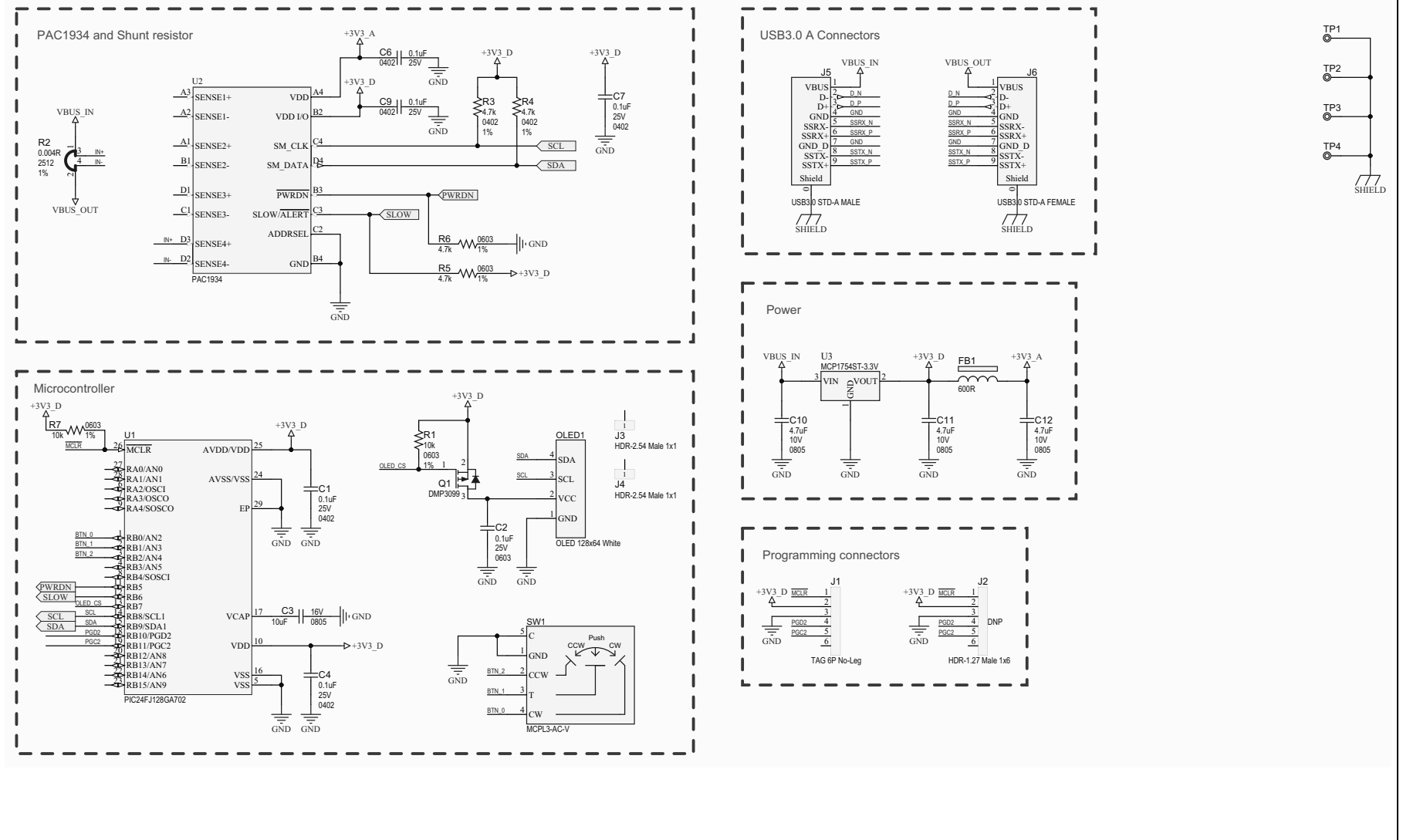

A.3 BOARD – TOP SILK LAYER (USB A)

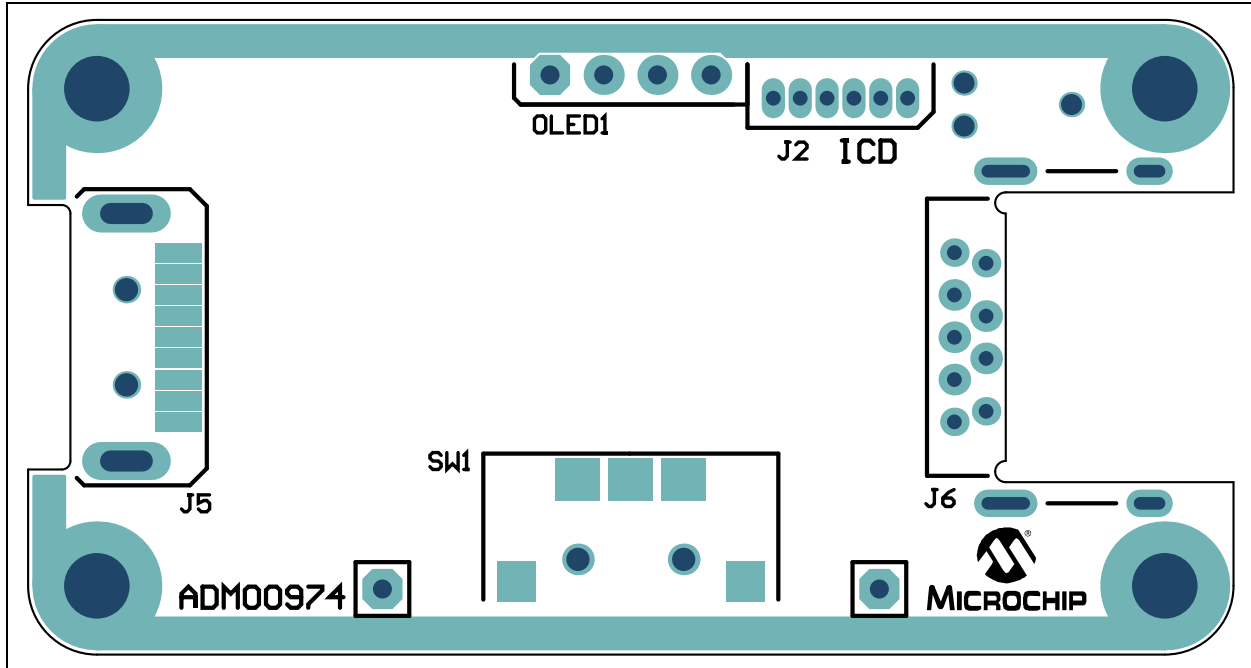

A.4 BOARD – TOP COPPER AND SILK LAYER (USB A)

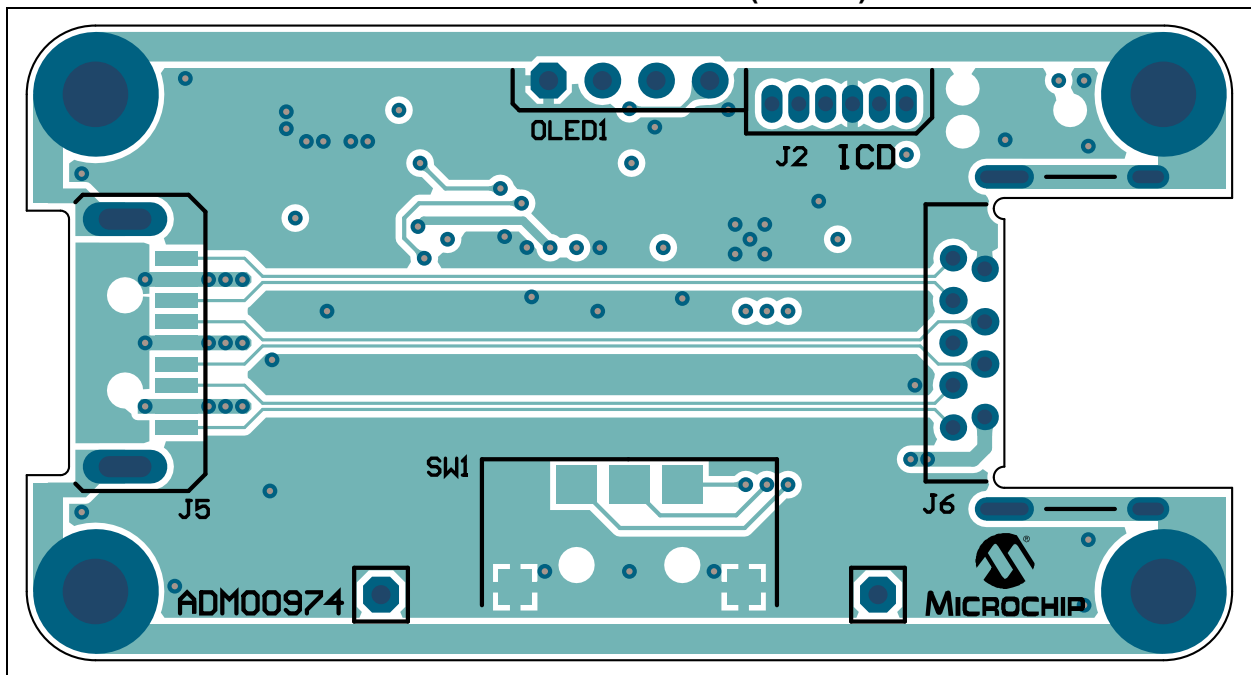

A.5 BOARD – TOP COPPER LAYER (USB A)

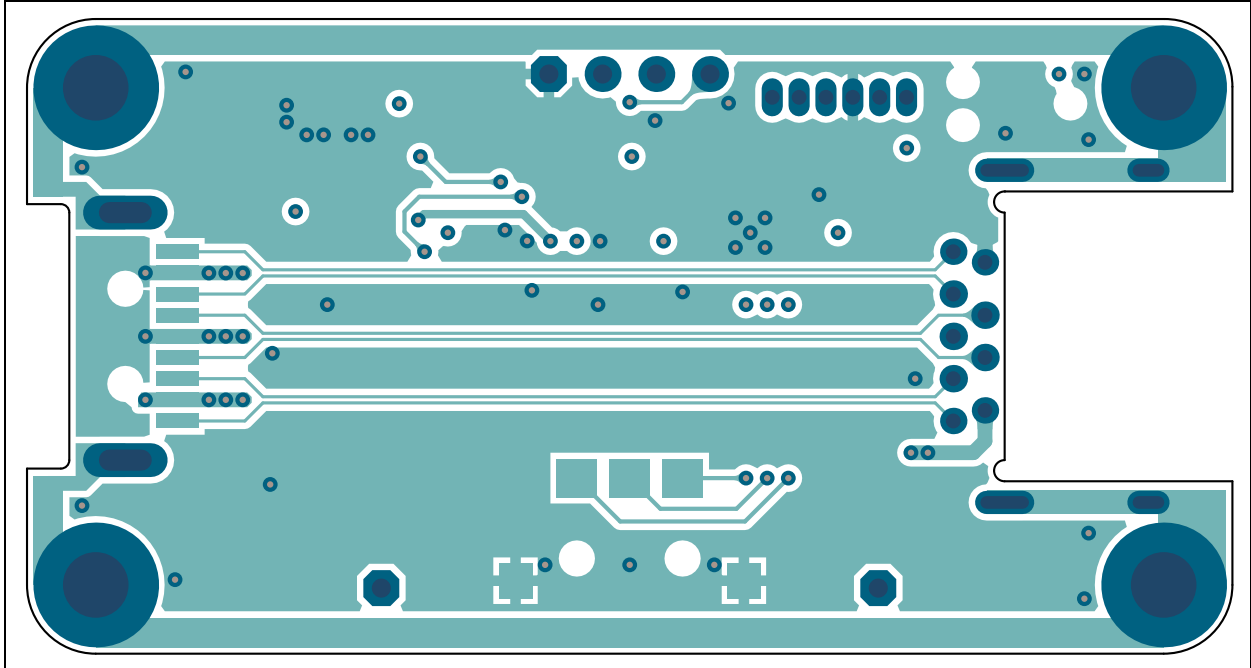

A.6 BOARD – INNER 1 LAYER (USB A)

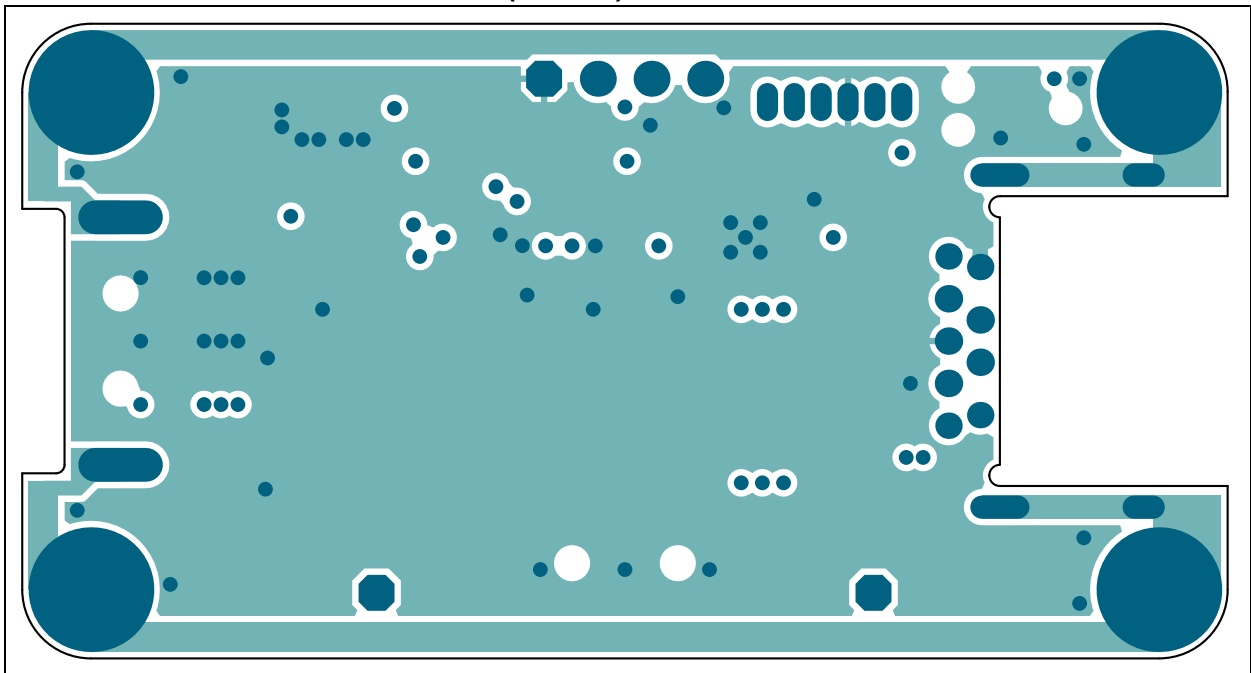

A.7 BOARD – INNER 2 LAYER (USB A)

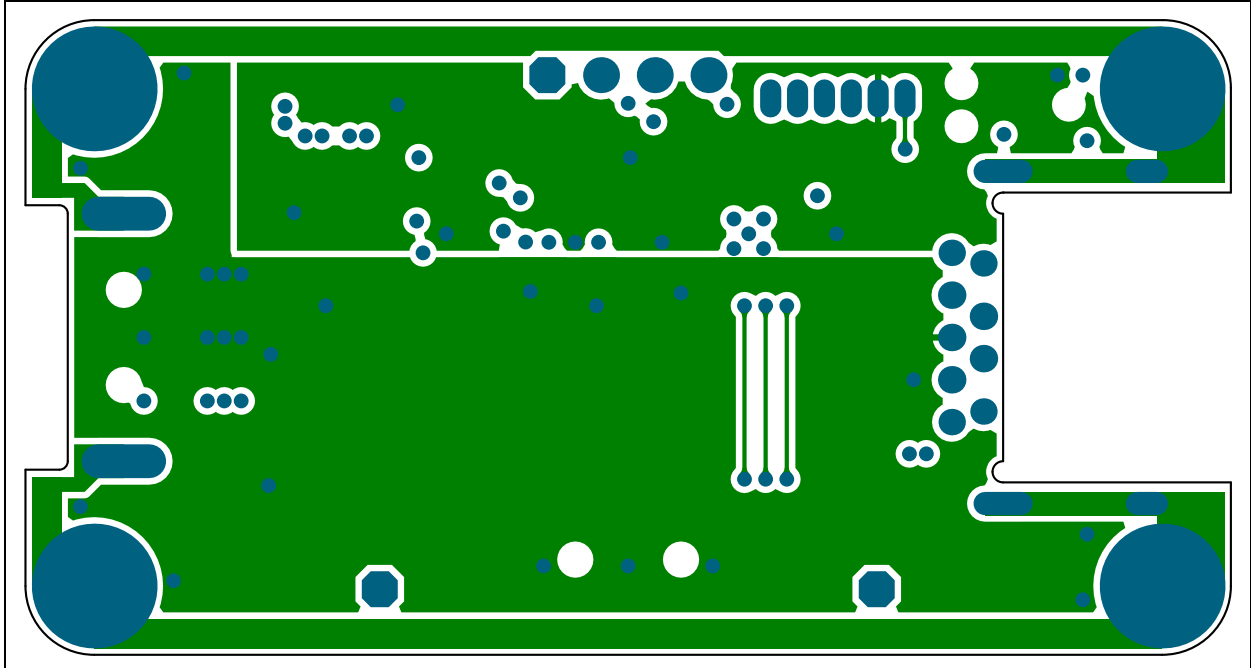

A.8 BOARD – BOTTOM COPPER LAYER (USB A)

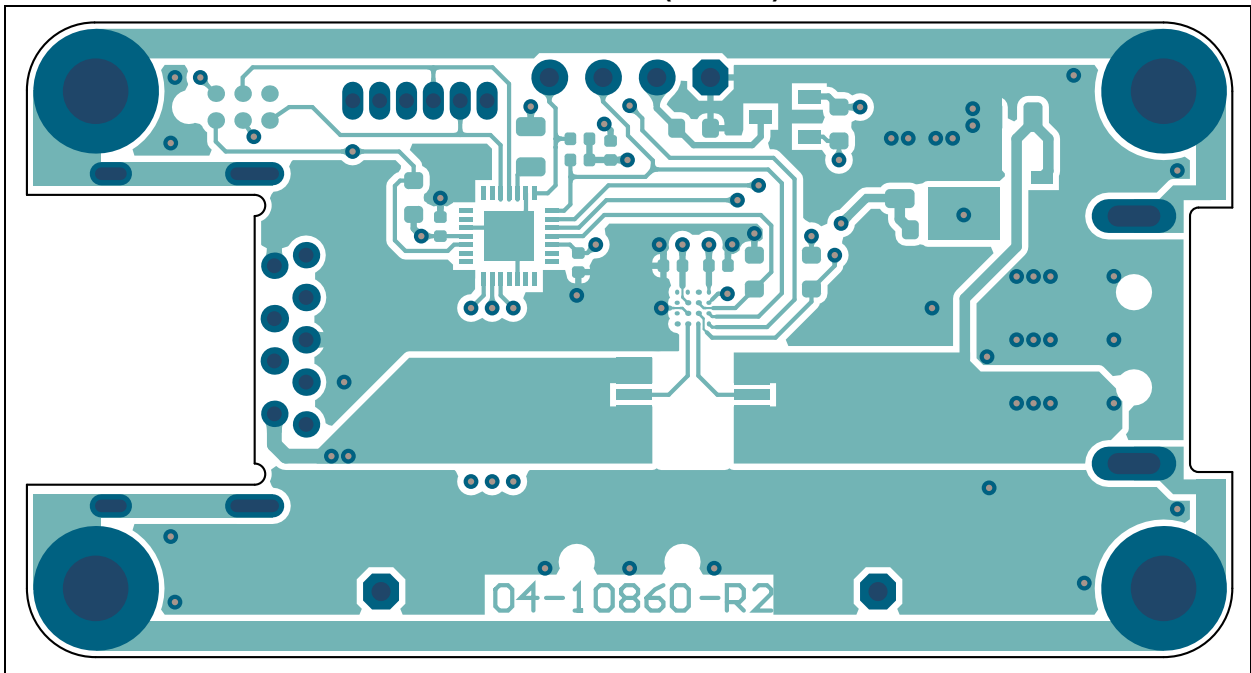

A.9 BOARD – BOTTOM COPPER AND SILK LAYER (USB A)

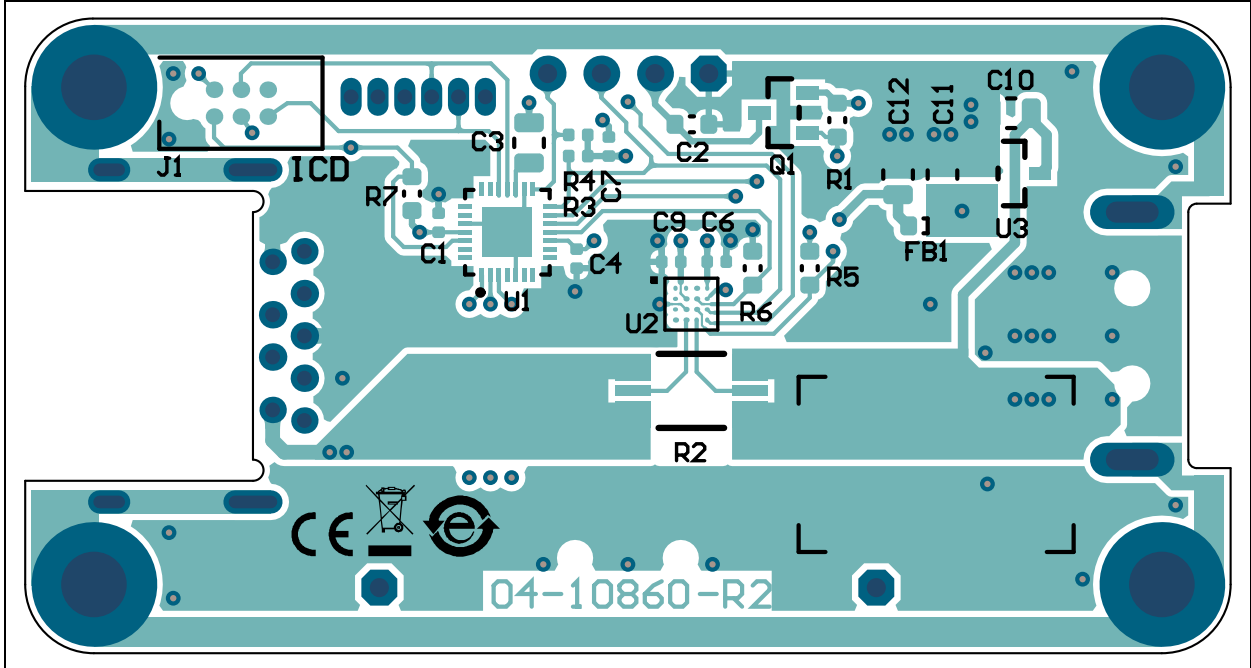

A.10 BOARD – BOTTOM SILK LAYER (USB A)

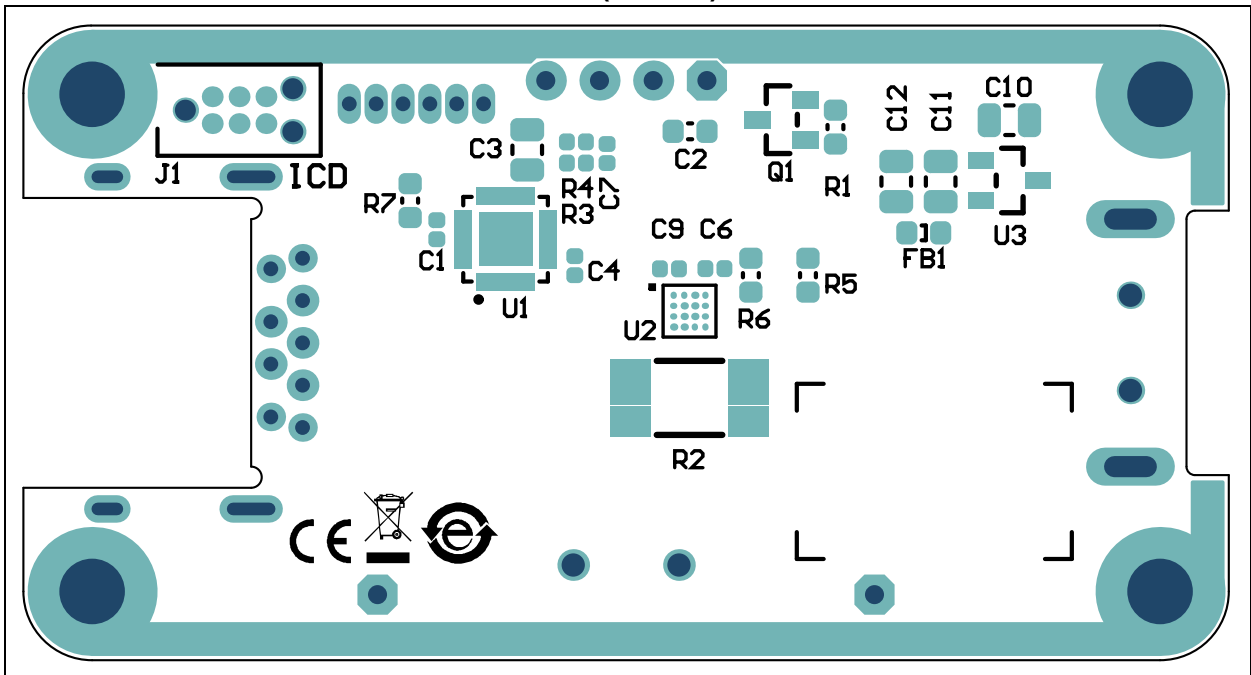

A.11 BOARD – SCHEMATIC (USB C) 1

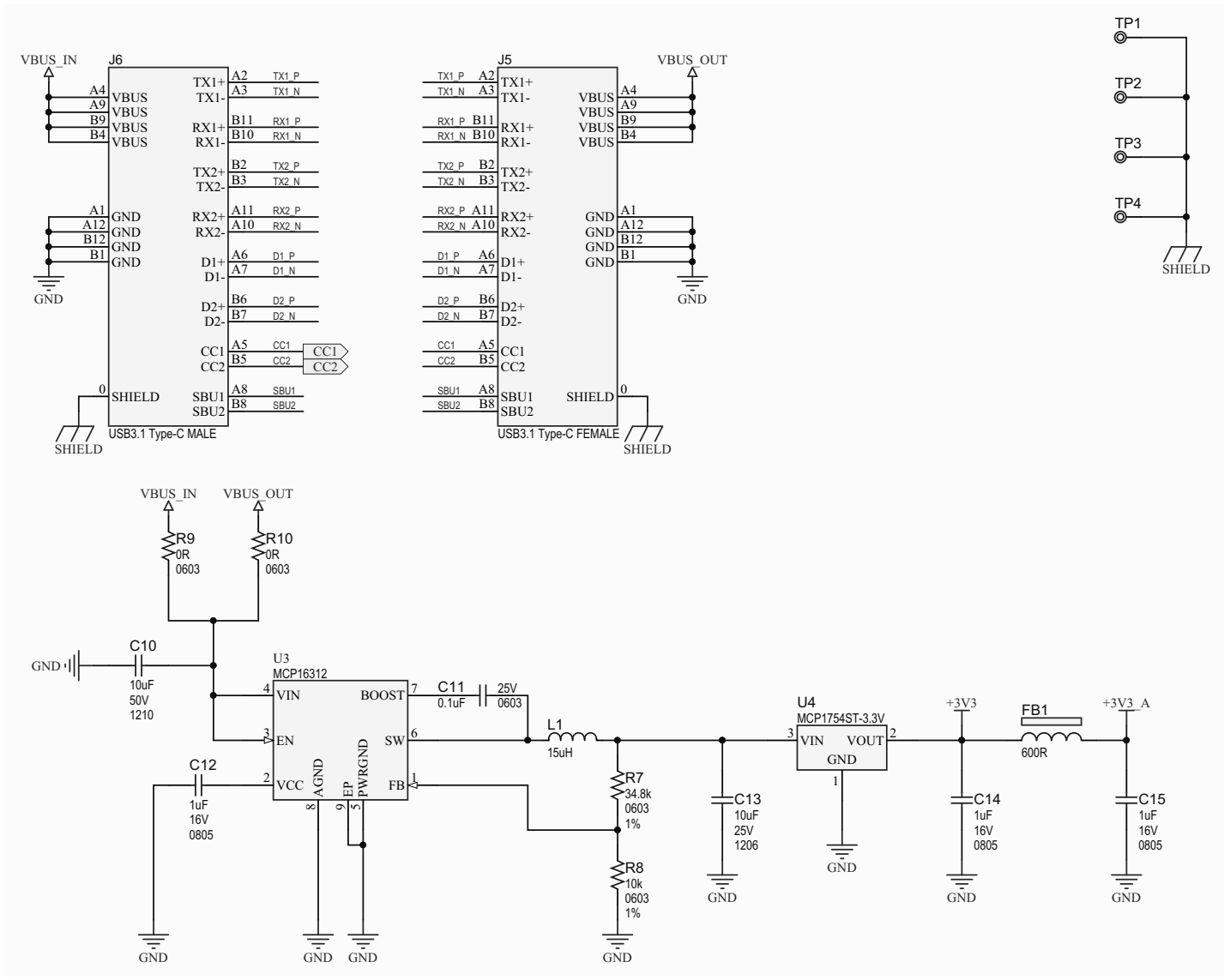

A.12 BOARD – SCHEMATIC (USB C) 2

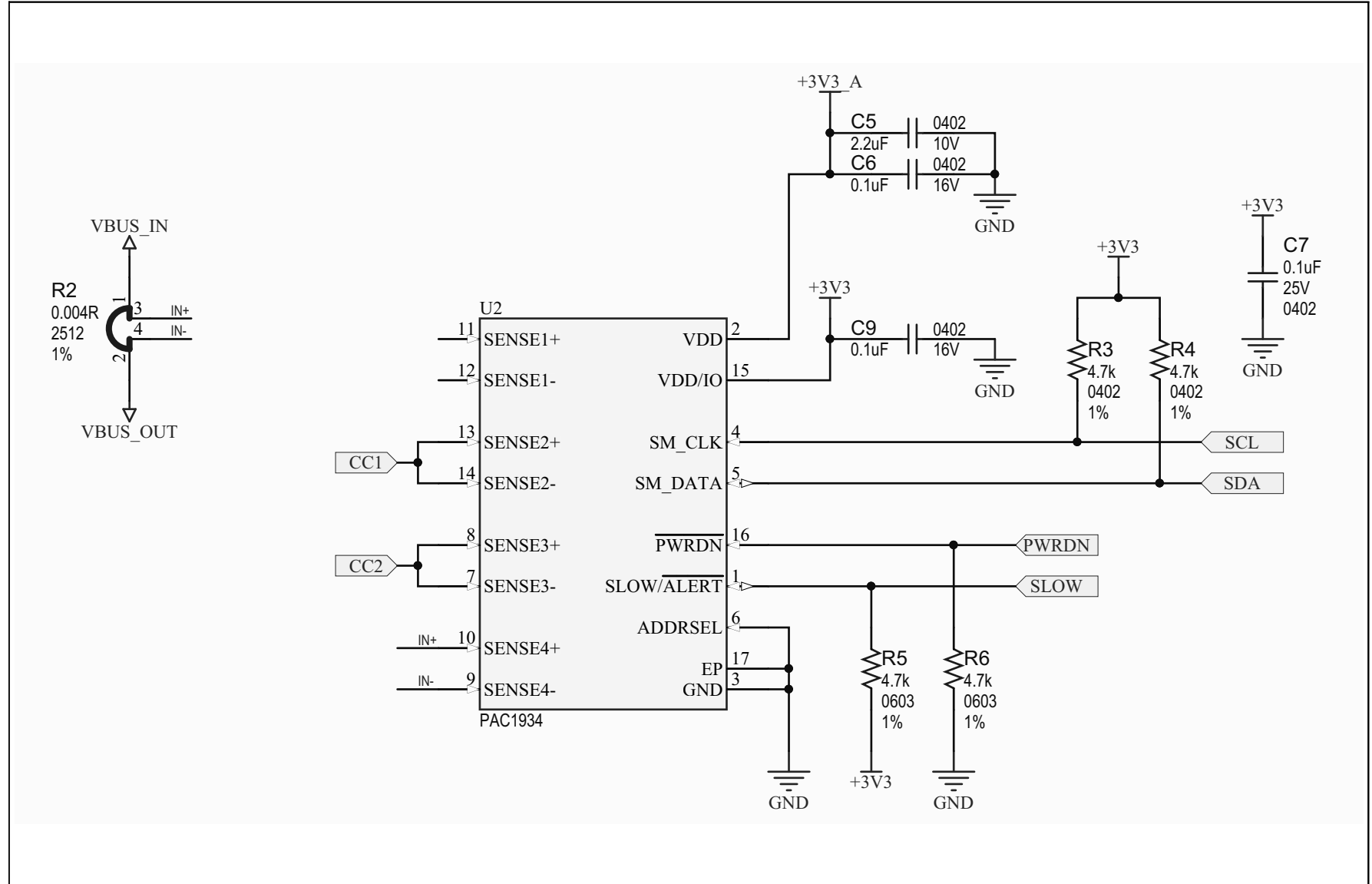

A.13 BOARD – SCHEMATIC (USB C) 3

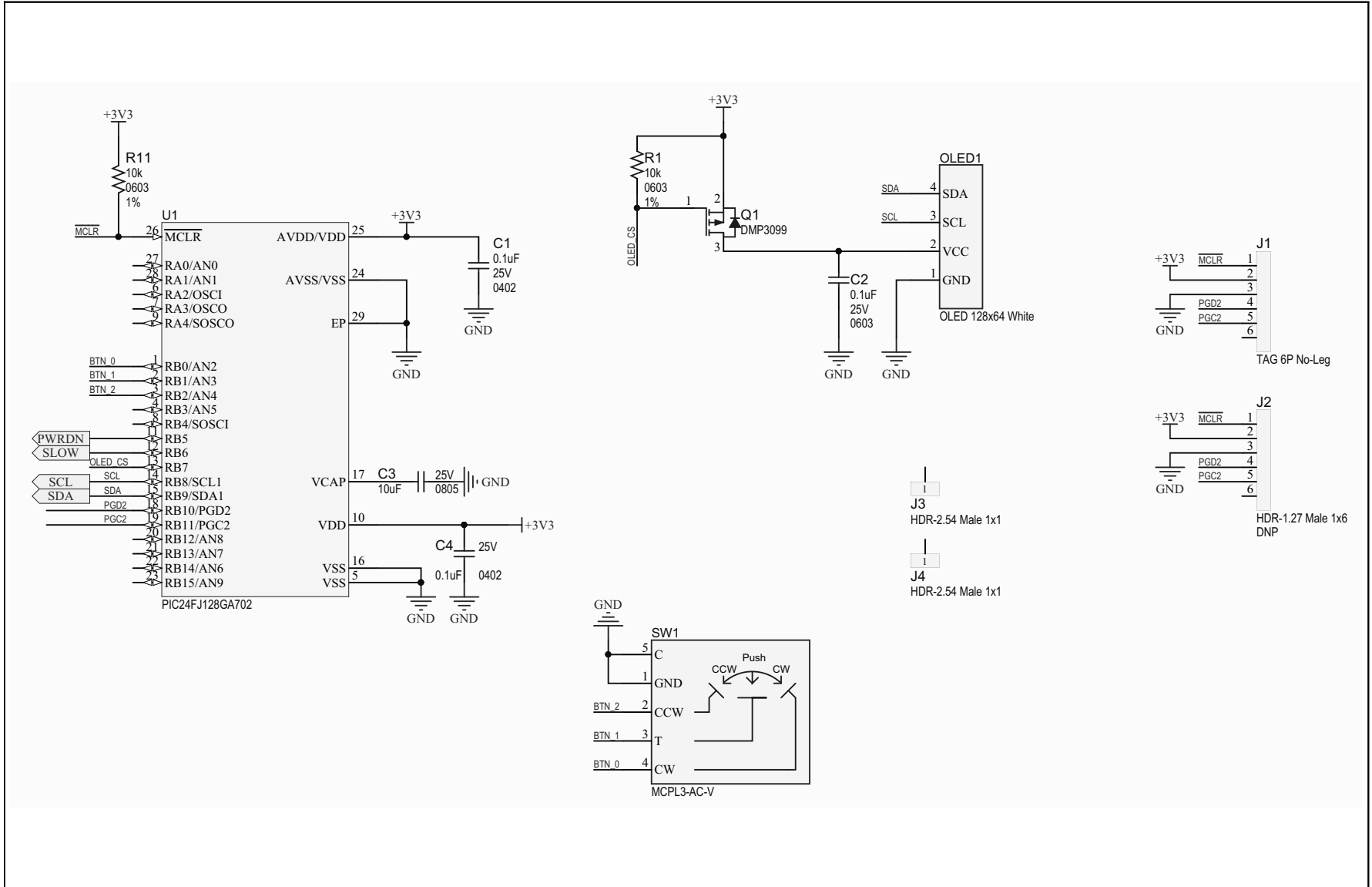

A.14 BOARD – TOP SILK LAYER (USB C)

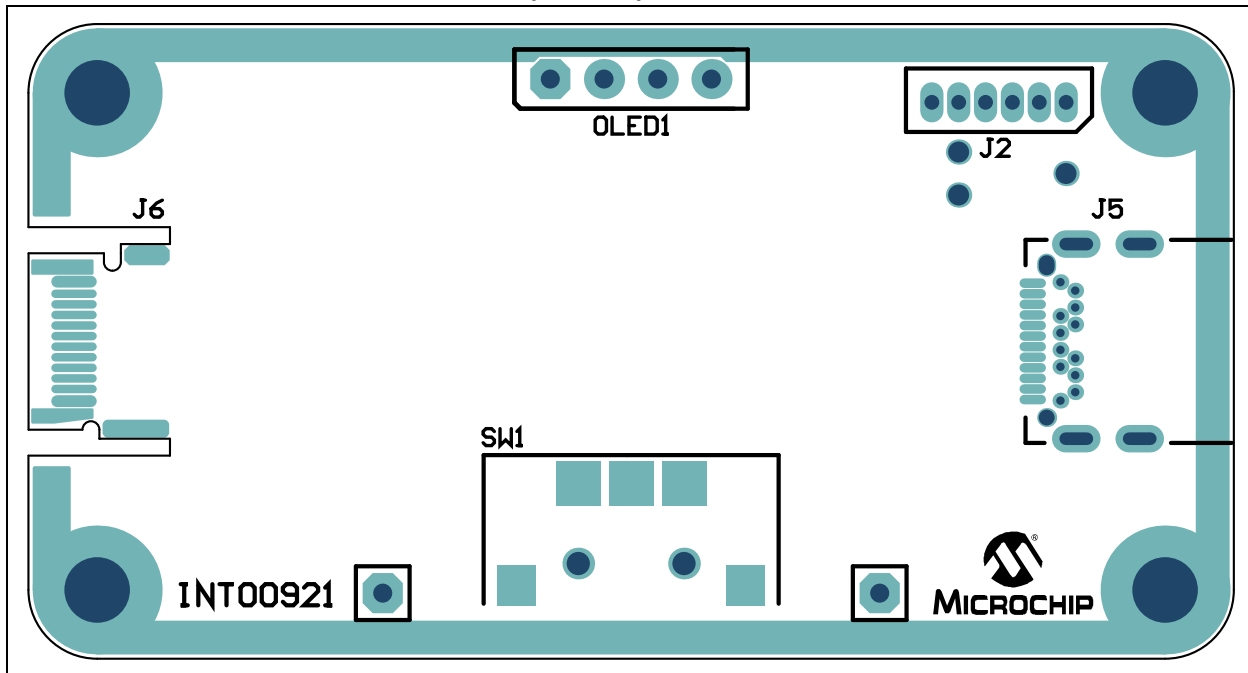

A.15 BOARD – TOP COPPER AND SILK LAYER (USB C)

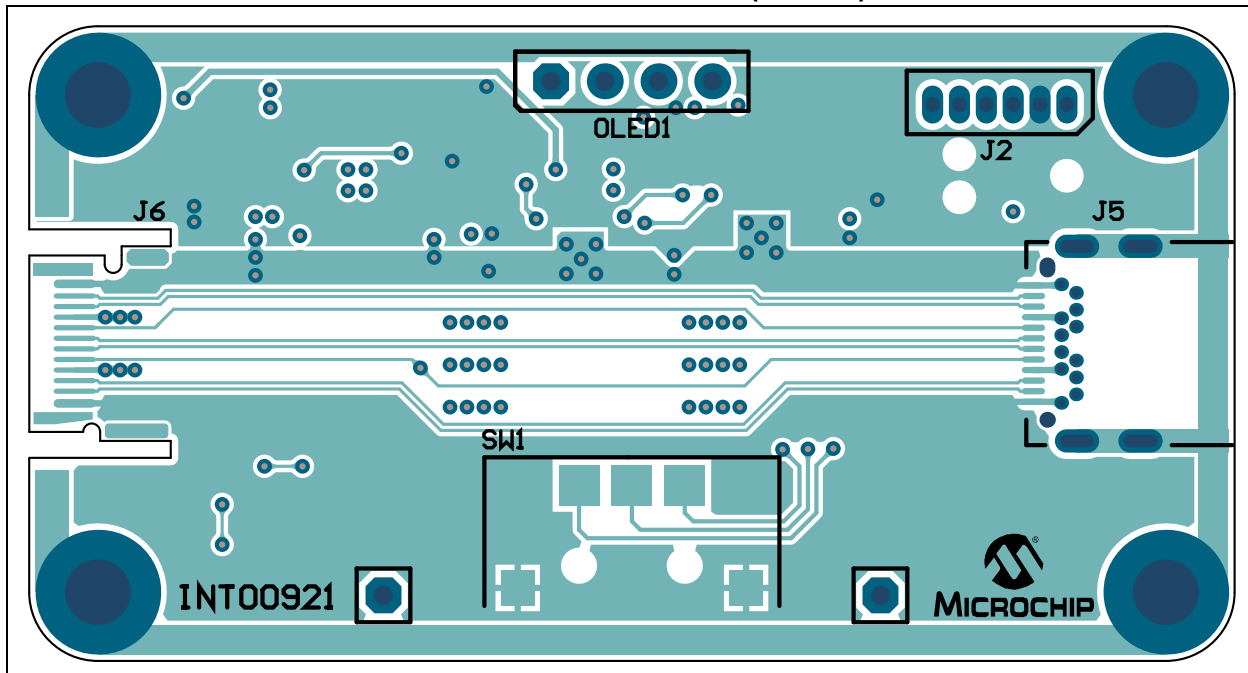

A.16 BOARD – TOP COPPER LAYER (USB C)

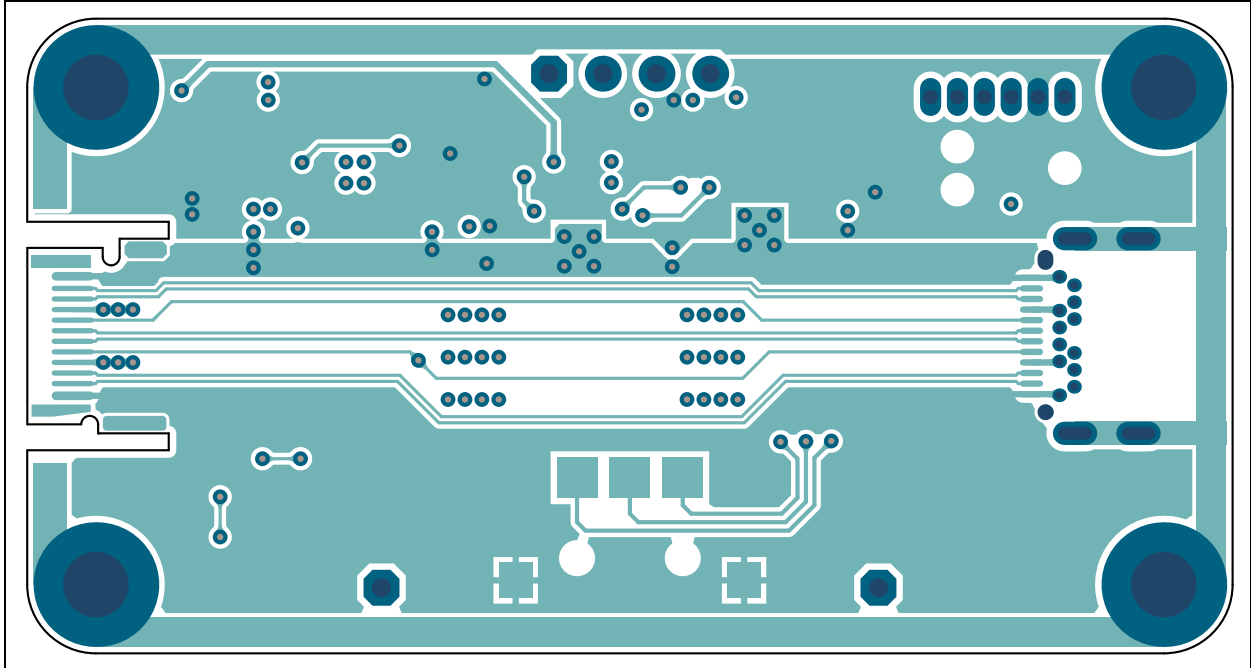

A.17 BOARD – BOTTOM COPPER LAYER (USB C)

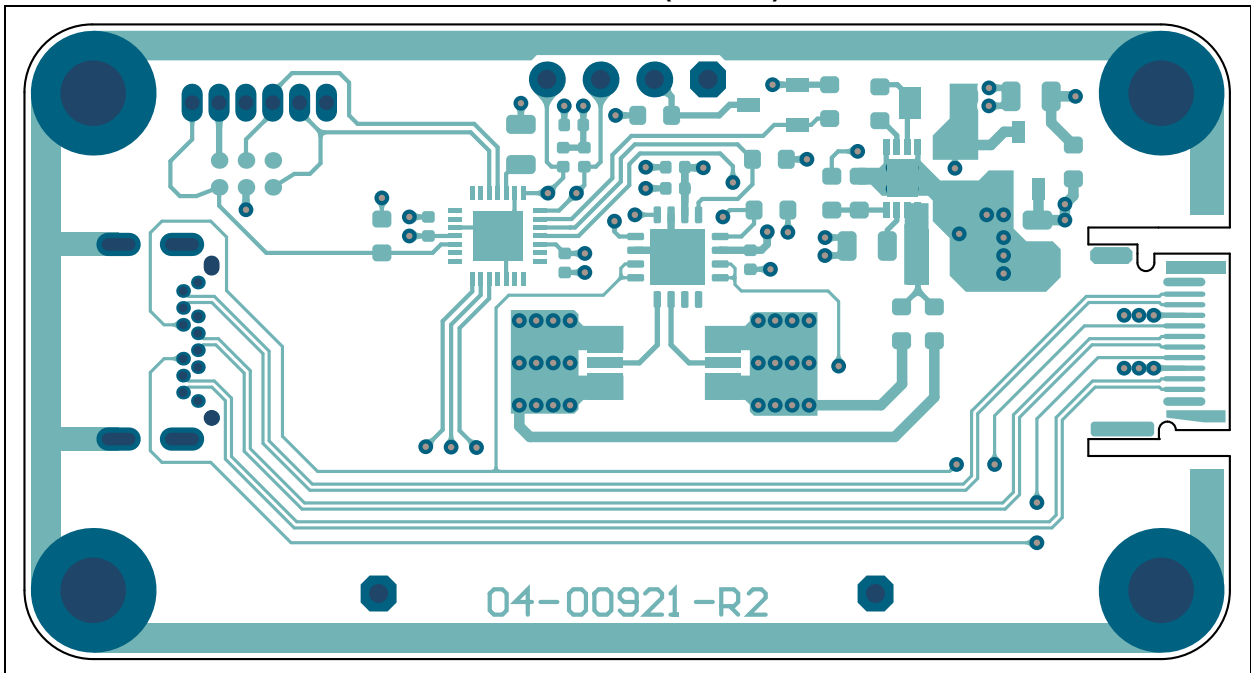

A.18 BOARD – BOTTOM COPPER AND SILK LAYER (USB C)

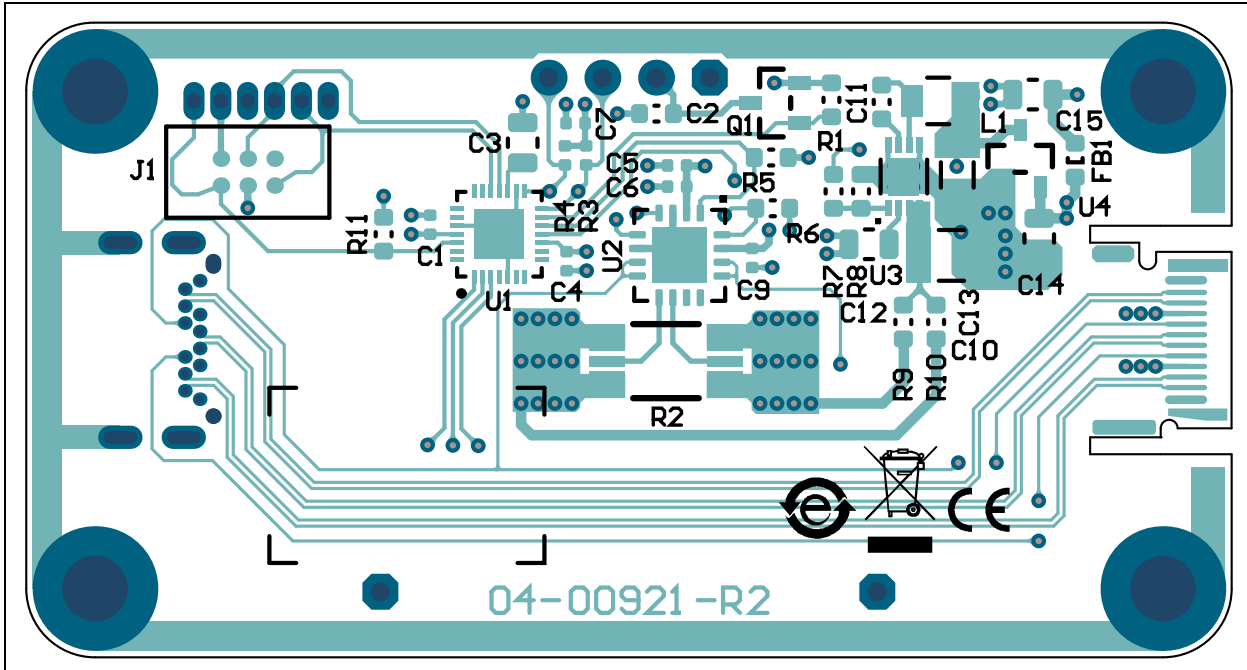

A.19 BOARD – BOTTOM SILK LAYER (USB C)

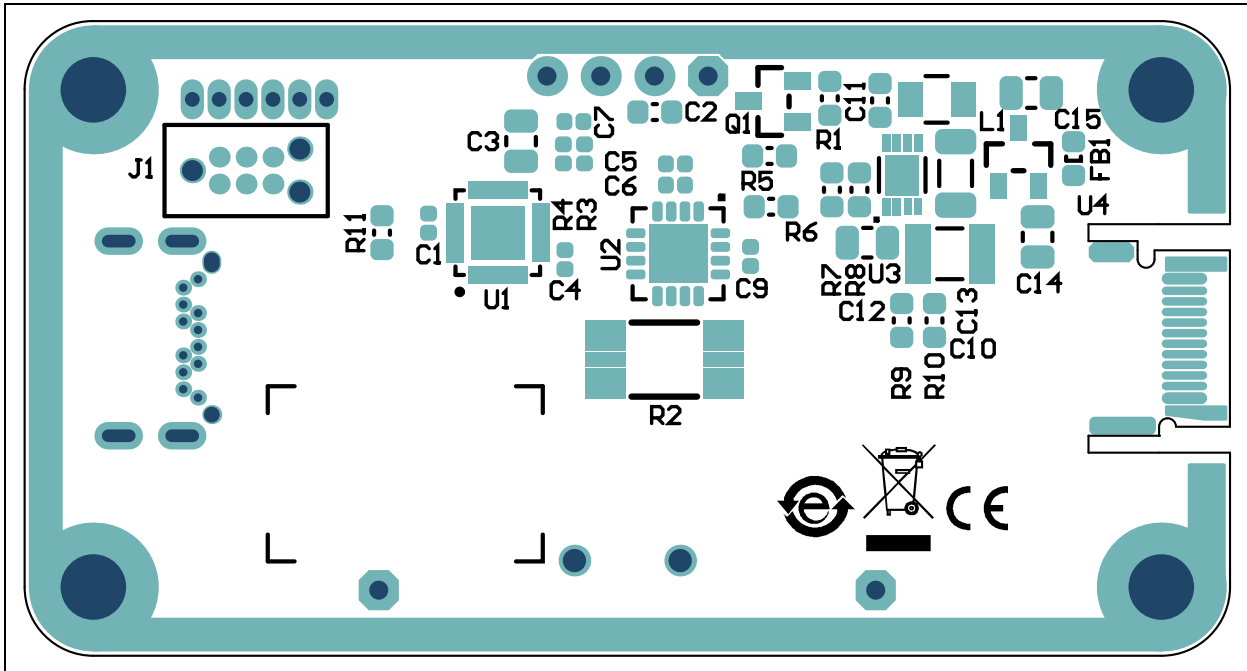

Appendix B. Bill of Materials (BOM)

TABLE B-1: BILL OF MATERIALS (BOM) FOR PAC1934 POWER METER (USB A)

Qty.	Reference	Description	Manufacturer	Part Number
5	C1, C4, C6, C7, C9	Cap. Ceramic 0.1 μ F 25V 10% X7R SMD 0402	TDK Corporation	C1005X7R1E104K050BB
1	C2	Cap. Ceramic 0.1 μ F 25V 10% X7R SMD 0603	TDK Corporation	C1608X7R1E104K
1	C3	Cap. Ceramic 10 μ F 16V 20% X5R SMD 0805	TDK Corporation	C2012X5R1C106M085AC
3	C10, C11, C12	Cap. Ceramic 4.7 μ F 10V 10% X5R SMD 0805	Taiyo Yuden Co., Ltd.	LMK212BJ475KD-T
1	FB1	FERRITE 600R@100 MHz 1A SMD 0603	Bourns [®] , Inc.	MH1608-601Y
2	J3, J4	Connector Header-2.54 Male 1x1 Gold 5.84 MH TH VERT	TE Connectivity, Ltd.	5-146868-1
1	J5	Connector USB3.0 STD-A Male SMD R/A	Würth Elektronik	692112030100
1	J6	Connector USB3.0 STD-A Female TH R/A	Würth Elektronik	692121230100
1	OLED1	Display OLED Module ARDUINO White 128 x 64 3.3-5V TH	Shenzhen Aiconnecting Electronic Co., Ltd.	128 x 64 I ² C IIC Serial white OLED ICD display module 0.96" 4-pin 96 inch for UNO R3 2560
1	PCB	PAC1934 Power Meter – Printed Circuit Board	Microchip Technology Inc.	04-10860
1	Q1	Transistor FET P-CH DMP3099L-7 -30V -3.8A 1.08W SOT-23-3	Diodes Incorporated [®]	DMP3099L-7
1	R1	Res. TKF 10 k Ω 1% 1/10W SMD 0603	Vishay/Dale	CRCW060310K0FKEA
1	R2	Res. Shunt MF 0.004R 1% 2W 2512	Stackpole Electronics, Inc.	CSNL2512FT4L00
2	R3, R4	Res. TKF 4.7 k Ω 1% 1/10W 0402	KOA Speer Electronics, Inc.	RK73H1ETTP4701F
2	R5, R6	Res. TKF 4.7 k Ω 1% 1/10W SMD 0603	Vishay/Dale	CRCW06034K70FKEA
1	R7	Res. TKF 10 k Ω 1% 1/10W SMD 0603	Xicon International Ltd.	302-10K-RC
1	SW1	Switch Joystick 3-WAY Mechanical 1 mA MCPL3-AC-V SMD R/A	Multicomp Inc.	MCPL3-AC-V
1	U1	Microchip MCU 16-BIT 32 MHz 128 kB 16K PIC24FJ128GA702-I/MV UQFN-28	Microchip Technology Inc.	PIC24FJ128GA702-I/MV
1	U2	Microchip Analog Power Current Sense Monitor PAC1934T-I/J6CX WLCSP-16	Microchip Technology Inc.	PAC1934T-I/J6CX
1	U3	Microchip Analog LDO 3.3V MCP1754ST-3302E/CB SOT-23A-3	Microchip Technology Inc.	MCP1754ST-3302E/CB

Note 1: The components listed in this Bill of Materials are representative of the PCB assembly. The released BOM used in manufacturing uses all RoHS-compliant components.

Bill of Materials (BOM)

TABLE B-2: BILL OF MATERIALS (BOM) FOR PAC1934 POWER METER (USB A) – MECHANICAL PARTS

Qty.	Reference	Description	Manufacturer	Part Number
1	LABEL1	Label, AIPD Board Assembly	—	—
4	NUT1, NUT2, NUT3, NUT4	Mech. HW NUT M3x3 mm HEX Zinc	Bossard Holding AG	M3/BN131
4	S1, S2, S3, S4	Mech. HW Stand-off M3x6 mm F/F HEX Zinc	Bossard Holding AG	M3X6/BN3319
4	SCR1, SCR3, SCR5, SCR7	Mech. HW Screw M3x3 mm Button Stainless Steel	AccuGroup®	SSB-M3-3-A2
4	SCR2, SCR4, SCR6, SCR8	Mech. HW Screw M3x8 mm Button Stainless Steel	AccuGroup	SSB-M3-8-A2

Note 1: The components listed in this Bill of Materials are representative of the PCB assembly. The released BOM used in manufacturing uses all RoHS-compliant components.

TABLE B-3: BILL OF MATERIALS (BOM) FOR PAC1934 POWER METER (USB A) – DO NOT POPULATE PARTS

Qty.	Reference	Description	Manufacturer	Part Number
1	J1	Connector TAG 6P No-Leg SMD VERT	Tag-Connect	TC2030-MCP-NL
1	J2	Connector HDR-1.27 Male 1x6 Gold 3MH TH R/A	Sullins Connector Solutions	GRPB061VWCN-RC

Note 1: The components listed in this Bill of Materials are representative of the PCB assembly. The released BOM used in manufacturing uses all RoHS-compliant components.

TABLE B-4: BILL OF MATERIALS (BOM) FOR PAC1934 POWER METER (USB C)

Qty.	Reference	Description	Manufacturer	Part Number
3	C1, C4, C7	Cap. CER 0.1 µF 25V 10% X7R SMD 0402	TDK Corporation	C1005X7R1E104K050BB
2	C2, C11	Cap. CER 0.1 µF 25V 10% X7R SMD 0603	Murata Electronics®	GRM188R71E104KA01D
1	C3	Cap. CER 10 µF 25V 10% X5R SMD 0805	TDK Corporation	C2012X5R1E106K125AB
1	C5	Cap. CER 2.2 µF 10V 10% X7S SMD 0402	TDK Corporation	C1005X7S1A225K050BC
2	C6, C9	Cap. CER 0.1 µF 16V 10% X7R SMD 0402	Murata Electronics	GRM155R71C104KA88D
1	C10	Cap. CER 10 µF 50V 10% X5R SMD 1210	Taiyo Yuden Co., Ltd.	UMK325BJ106KM-T
3	C12, C14, C15	Cap. CER 1 µF 16V 10% X7R SMD 0805	Würth Elektronik	885012207051
1	C13	Cap. CER 10 µF 25V 10% X7R SMD 1206	Murata Electronics	GRM31CR71E106KA12L
1	FB1	FERRITE 600R@100 MHz 1A SMD 0603	Bourns®, Inc.	MH1608-601Y
2	J3, J4	Connector HDR-2.54 Male 1x1 Gold 5.84MH TH VERT	TE Connectivity	5-146280-1
1	J5	Connector USB3.1 TYPE-C Female SMD R/A	JAE Electronics, Inc.	DX07S024XJ1R1100
1	J6	Connector USB3.1 TYPE-C Male SMD R/A	JAE Electronics, Inc.	DX07P024MJ1R1500
1	L1	Inductor 15 µH 325 mA 10% SMD 1008	Würth Elektronik	7447629150

Note 1: The components listed in this Bill of Materials are representative of the PCB assembly. The released BOM used in manufacturing uses all RoHS-compliant components.

Bill of Materials (BOM)

TABLE B-4: BILL OF MATERIALS (BOM) FOR PAC1934 POWER METER (USB C) (CONTINUED)

Qty.	Reference	Description	Manufacturer	Part Number
1	OLED1	Display OLED Module ARDUINO White 128 x 64 3.3-5V TH	Shenzhen Aiconnecting Elec- tronic Co., Ltd.	128 x 64 I2C IIC Serial white OLED ICD display module 0.96" 4-pin 96 inch for UNO R3 2560
1	PCB	PAC1934 Power Meter – Printed Circuit Board	Microchip Technology Inc.	04-00921
1	Q1	Transistor FET P-CH DMP3099L-7 -30V -3.8A 1.08W SOT-23-3	Diodes Incorporated®	DMP3099L-7
2	R1, R8	Res. TKF 10 kΩ 1% 1/10W SMD 0603	ROHM Semiconductor	MCR03EZPFX1002
1	R2	Res. Shunt MF 0.004R 1% 2W 2512	Stackpole Electronics Inc	CSNL2512FT4L00
2	R3, R4	Res. TKF 4.7 kΩ 1% 1/10W 0402	KOA Speer Electronics, Inc.	RK73H1ETTP4701F
2	R5, R6	Res. TKF 4.7 kΩ 1% 1/10W SMD 0603	Vishay/Dale	CRCW06034K70FKEA
1	R7	Res. TKF 34.8 kΩ 1% 1/10W SMD 0603	Panasonic® – ECG	ERJ-3EKF3482V
2	R9, R10	Res. TKF 0R 1/10W SMD 0603	Panasonic – ECG	ERJ-3GSY0R00V
1	R11	Res. TKF 10 kΩ 1% 1/10W SMD 0603	Panasonic – ECG	ERJ-3EKF1002V
1	SW1	Switch Joystick 3-Way Mechanical 1 mA MCPL3-AC-V SMD R/A	Multicomp Inc.	MCPL3-AC-V
1	U1	Microchip MCU 16-BIT 32 MHz 128kB 16K PIC24FJ128GA702-I/MV UQFN-28	Microchip Technology Inc.	PIC24FJ128GA702-I/MV
1	U2	Microchip Analog Power Current Sense Monitor PAC1934-I/JQ UQFN-16	Microchip Technology Inc.	PAC1934-I/JQ
1	U3	Microchip Analog Switcher Buck 2V to 24V MCP16312-E/MNY TDFN-8	Microchip Technology Inc.	MCP16312T-E/MNY
1	U4	Microchip Analog LDO 3.3V MCP1754ST-3302E/CB SOT-23A-3	Microchip Technology Inc.	MCP1754ST-3302E/CB

Note 1: The components listed in this Bill of Materials are representative of the PCB assembly. The released BOM used in manufacturing uses all RoHS-compliant components.

TABLE B-5: BILL OF MATERIALS (BOM) FOR PAC1934 POWER METER (USB C) – MECHANICAL PARTS

Qty.	Reference	Description	Manufacturer	Part Number
1	LABEL1	Label, AIPD Board Assembly	—	—
4	NUT1, NUT2, NUT3, NUT4	Mech. HW Nut M3x3 mm HEX Zinc	Bossard Holding AG	M3/BN131
4	S1, S2, S3, S4	Mech. HW Stand-off M3x6 mm F/F HEX Zinc	Bossard Holding AG	M3X6/BN3319
20	SCR1, SCR3, SCR5, SCR7	Mech. HW Screw M3x6 mm PanHead PHIL Zinc	Bossard Holding AG	1154249
4	SCR2, SCR4, SCR6, SCR8	Mech. HW Screw M3x3 mm PanHead PHIL Zinc	KRAFTBERG	M3X3/D7985

Note 1: The components listed in this Bill of Materials are representative of the PCB assembly. The released BOM used in manufacturing uses all RoHS-compliant components.

Bill of Materials (BOM)

TABLE B-6: BILL OF MATERIALS (BOM) FOR PAC1934 POWER METER (USB C) – DO NOT POPULATE PARTS

Qty.	Reference	Description	Manufacturer	Part Number
1	J1	Connector TAG 6P No-Leg SMD VERT	Tag-Connect	TC2030-MCP-NL
1	J2	Connector HDR-1.27 Male 1x6 Gold 3MH TH R/A	Sullins Connector Solutions	GRP061VWCN-RC

Note 1: The components listed in this Bill of Materials are representative of the PCB assembly. The released BOM used in manufacturing uses all RoHS-compliant components.



MICROCHIP

Worldwide Sales and Service

AMERICAS

Corporate Office
2355 West Chandler Blvd.
Chandler, AZ 85224-6199
Tel: 480-792-7200
Fax: 480-792-7277
Technical Support:
<http://www.microchip.com/support>
Web Address:
www.microchip.com

Atlanta

Duluth, GA
Tel: 678-957-9614
Fax: 678-957-1455

Austin, TX

Tel: 512-257-3370

Boston

Westborough, MA
Tel: 774-760-0087
Fax: 774-760-0088

Chicago

Itasca, IL
Tel: 630-285-0071
Fax: 630-285-0075

Dallas

Addison, TX
Tel: 972-818-7423
Fax: 972-818-2924

Detroit

Novi, MI
Tel: 248-848-4000

Houston, TX

Tel: 281-894-5983

Indianapolis

Noblesville, IN
Tel: 317-773-8323
Fax: 317-773-5453
Tel: 317-536-2380

Los Angeles

Mission Viejo, CA
Tel: 949-462-9523
Fax: 949-462-9608
Tel: 951-273-7800

Raleigh, NC

Tel: 919-844-7510

New York, NY

Tel: 631-435-6000

San Jose, CA

Tel: 408-735-9110
Tel: 408-436-4270

Canada - Toronto

Tel: 905-695-1980
Fax: 905-695-2078

ASIA/PACIFIC

Australia - Sydney
Tel: 61-2-9868-6733

China - Beijing
Tel: 86-10-8569-7000

China - Chengdu
Tel: 86-28-8665-5511

China - Chongqing
Tel: 86-23-8980-9588

China - Dongguan
Tel: 86-769-8702-9880

China - Guangzhou
Tel: 86-20-8755-8029

China - Hangzhou
Tel: 86-571-8792-8115

China - Hong Kong SAR
Tel: 852-2943-5100

China - Nanjing
Tel: 86-25-8473-2460

China - Qingdao
Tel: 86-532-8502-7355

China - Shanghai
Tel: 86-21-3326-8000

China - Shenyang
Tel: 86-24-2334-2829

China - Shenzhen
Tel: 86-755-8864-2200

China - Suzhou
Tel: 86-186-6233-1526

China - Wuhan
Tel: 86-27-5980-5300

China - Xian
Tel: 86-29-8833-7252

China - Xiamen
Tel: 86-592-2388138

China - Zhuhai
Tel: 86-756-3210040

ASIA/PACIFIC

India - Bangalore
Tel: 91-80-3090-4444

India - New Delhi
Tel: 91-11-4160-8631

India - Pune
Tel: 91-20-4121-0141

Japan - Osaka
Tel: 81-6-6152-7160

Japan - Tokyo
Tel: 81-3-6880-3770

Korea - Daegu
Tel: 82-53-744-4301

Korea - Seoul
Tel: 82-2-554-7200

Malaysia - Kuala Lumpur
Tel: 60-3-7651-7906

Malaysia - Penang
Tel: 60-4-227-8870

Philippines - Manila
Tel: 63-2-634-9065

Singapore
Tel: 65-6334-8870

Taiwan - Hsin Chu
Tel: 886-3-577-8366

Taiwan - Kaohsiung
Tel: 886-7-213-7830

Taiwan - Taipei
Tel: 886-2-2508-8600

Thailand - Bangkok
Tel: 66-2-694-1351

Vietnam - Ho Chi Minh
Tel: 84-28-5448-2100

EUROPE

Austria - Wels
Tel: 43-7242-2244-39
Fax: 43-7242-2244-393

Denmark - Copenhagen
Tel: 45-4450-2828
Fax: 45-4485-2829

Finland - Espoo
Tel: 358-9-4520-820

France - Paris
Tel: 33-1-69-53-63-20
Fax: 33-1-69-30-90-79

Germany - Garching
Tel: 49-8931-9700

Germany - Haan
Tel: 49-2129-3766400

Germany - Heilbronn
Tel: 49-7131-67-3636

Germany - Karlsruhe
Tel: 49-721-625370

Germany - Munich
Tel: 49-89-627-144-0
Fax: 49-89-627-144-44

Germany - Rosenheim
Tel: 49-8031-354-560

Israel - Ra'anana
Tel: 972-9-744-7705

Italy - Milan
Tel: 39-0331-742611
Fax: 39-0331-466781

Italy - Padova
Tel: 39-049-7625286

Netherlands - Drunen
Tel: 31-416-690399
Fax: 31-416-690340

Norway - Trondheim
Tel: 47-7288-4388

Poland - Warsaw
Tel: 48-22-3325737

Romania - Bucharest
Tel: 40-21-407-87-50

Spain - Madrid
Tel: 34-91-708-08-90
Fax: 34-91-708-08-91

Sweden - Gothenberg
Tel: 46-31-704-60-40

Sweden - Stockholm
Tel: 46-8-5090-4654

UK - Wokingham
Tel: 44-118-921-5800
Fax: 44-118-921-5820