

F
E
D
C
B
A

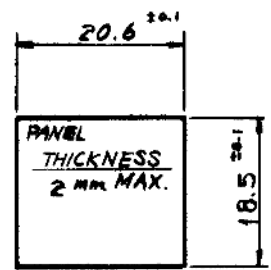

MOUNTING HOLE DETAIL (SCALE 1:1)

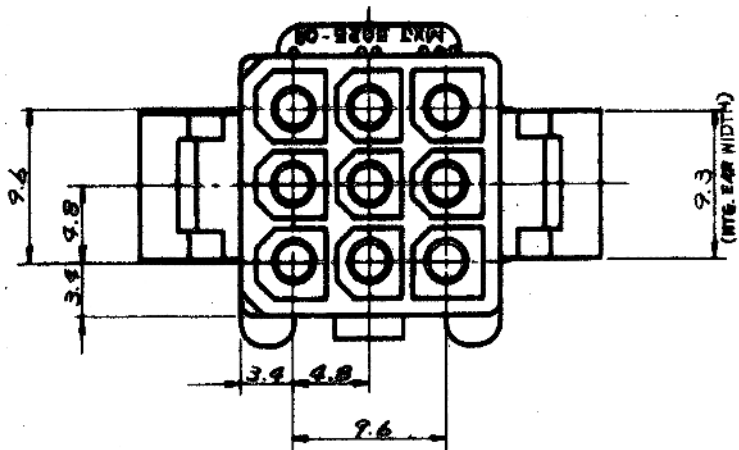
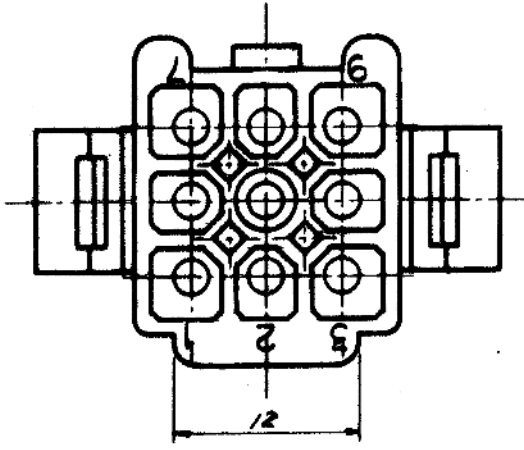
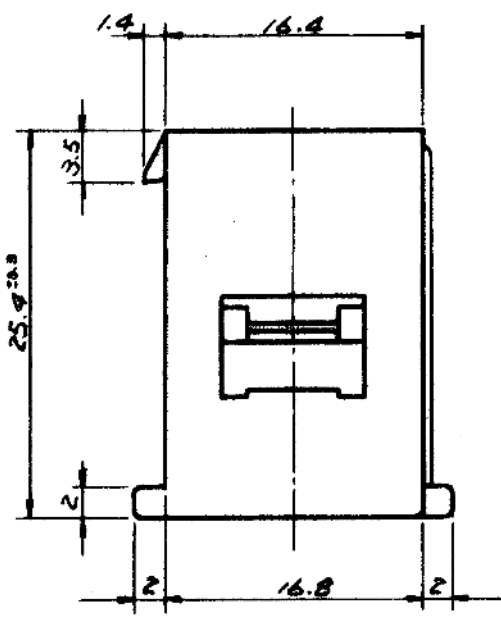
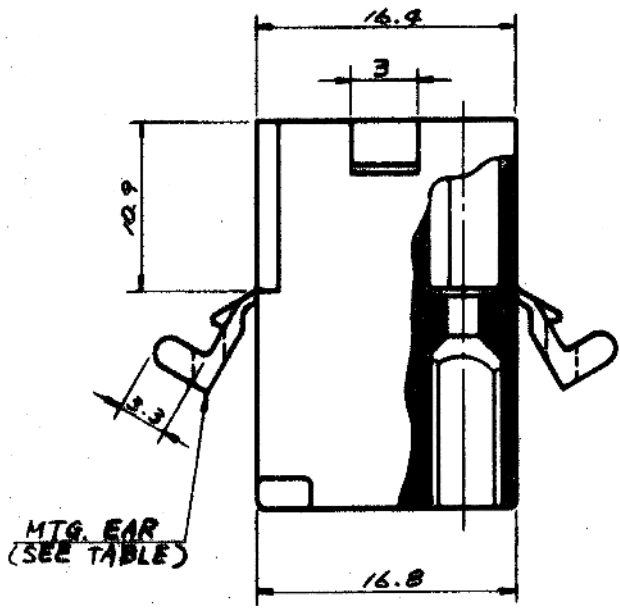

GENERAL TOLERANCES	
10 UNDER	±0.2
10 OVER 30 UNDER	±0.25
30 OVER	±0.3
ANGLE	±3°

	5025-09P1	NO
	5025-09P	YES
EDP NO.	ENG. NO.	MTG. EAR

		公差 (Tolerances) .000 → ±0.005 .00 → ±0.05 .0 → ±0.1 . → ±0.3	所要数 (Req)	DRWG. <i>Y. Arano 8/9 '77</i> DSN'D <i>M. ENDO/DT 1/76</i> CHK'D <i>W. S. ...</i> APP'D
		材料 (MAT'L) NYLON 66, 94V-2	MOLEX 日本モレックス株式会社	No. SD-5025-09P* REV. D
D	ADDED -09P1 EGN NO. 917	熱処理 (H.T.) HRc		
C	REMOVED "X" EGN NO. 748	仕上げ (Finish) —	Scale 2/1 名称 (Name) MINI. FIT CONN. 9POS. PLUG HSG.	
B	リットル加工の付加			
A	REVISED			
O	PROPOSED			
記号 (LTD)	変更内容 (Rev.)	Date	Name	

5 4 3 2 1

F
E
D
C
B
A

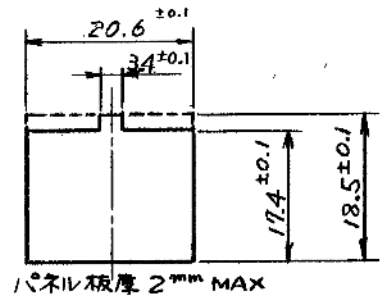
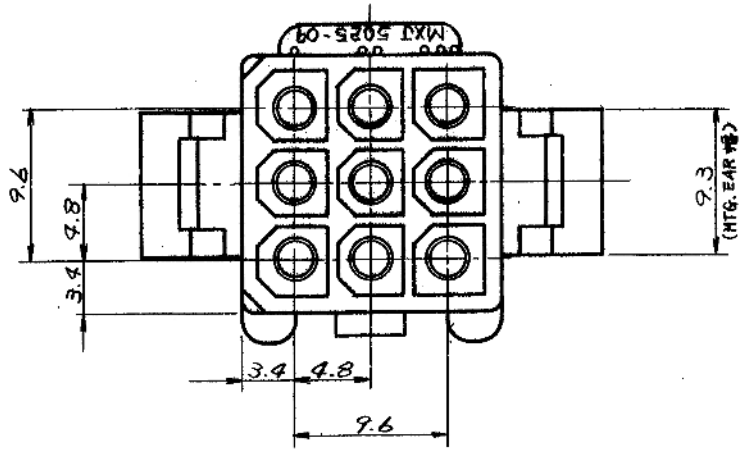

パネルスロット寸法 (SCALE 1:1)

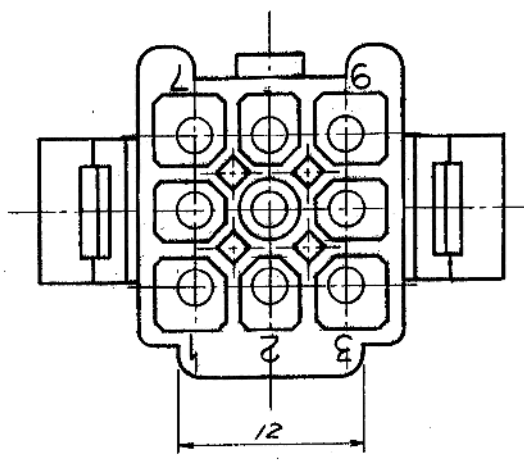
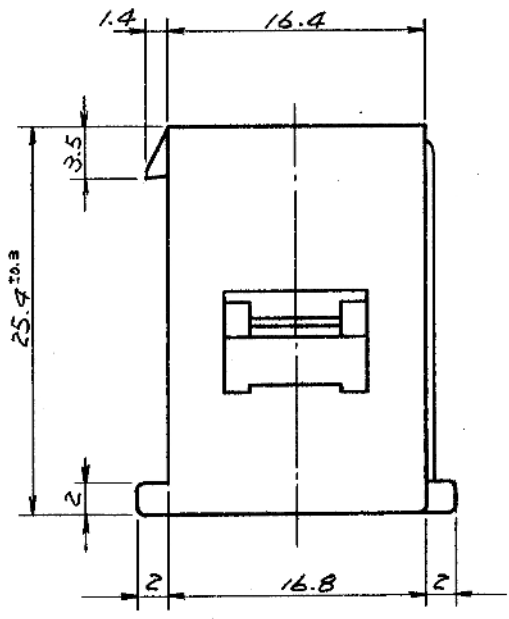
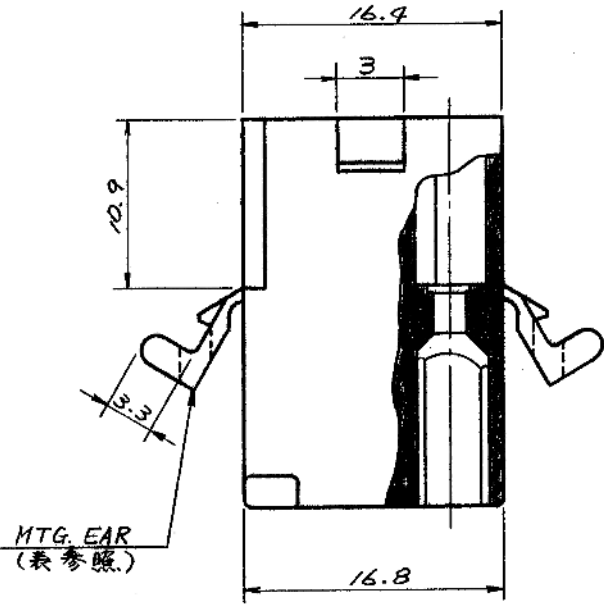

一般公差	
10未満	±0.2
10以上30未満	±0.25
30以上	±0.3
角度	±3°

15-31-1093	5025-09P1	無
15-31-1091	5025-09P	有
EDP NO.	ENG. NO.	MTG. EAR

			公差 (Tolerances) .000 → ±0.005, .00 → ±0.05 .0 → ±0.1, . → ±0.3	所要数 (Req)	DRWG. <i>Y. Awano</i> 9/29 '77
			材料 (MAT'L) NYLON66, 94V-2		DSN'D <i>M. ENDO</i> 10/10 '77
			熱処理 (H.T.) HRc —	MOLEX-JAPAN CO., LTD. 日本モレックス株式会社	CHK'D <i>W. Williams</i>
E	REVISED	ECN NO. 1499	11/30/79		K.H.
D	ADDED	-09P1 ECN NO. 917	9/5/78	Y.	
C	REMOVED	"X" ECN NO. 748	7/18/78	Y.	
B		リ丁、パネルスロット、サキット NO.	12/19/77	Y.	
A	REVISED		10/28/77	Y.	
O	PROPOSED		9/29/77	Y.	
記号 (LTR)	変更内容 (Rev.)	Date	Name	Scale 2/1	名称 (Name) MINI. FIT CONN. 9POS. PLUG HSG.
				No.	REV. E



No. SD-5025-09P*