

Data Sheet

Customer:

Product: Multilayer Ferrite Chip Inductor-ML(H) Series

Sizes.: 0603/0805/0806/1008/1206

Issued Date: 16-May-19

Edition: REV.B3



VIKING TECH CORPORATION
光韻科技股份有限公司
No.70, Guangfu N. Rd., Hukou
Township, Hsinchu County
303, Taiwan (R.O.C)

TEL:886-3-5972931
FAX:886-3-5972935•886-3-5973494
E-mail:sales@viking.com.tw

VIKING TECH CORPORATION KAOHSIUNG BRANCH
光韻科技股份有限公司高雄分公司
No.248-3, Sin-Sheng Rd., Cian-Jhen Dist., Kaohsiung,
806, Taiwan

TEL:886-7-8217999
FAX:886-7-8228229
E-mail:sales@viking.com.tw

VIKING ELECTRONICS (WUXI) CO., LTD.
光韻電子(無錫)有限公司
No.22 Xixia Road, Machinery & Industry Park,
National Hi-Tech Industrial Development Zone
of Wuxi, Wuxi, Jiangsu Province, China
Zip Code:214028
TEL:86-510-85203339
FAX:86-510-85203667•86-510-85203977
E-mail:china@viking.com.tw

Produced by (QC)	Checked (QC)	Approved by (QC)	Prepared by (Sales)	Accepted by (Customer)
16-May-19	16-May-19	16-May-19	16-May-19	
<i>Kris Chen</i>	<i>Ben Chang</i>	<i>Ben Chang</i>		

Multilayer Ferrite Chip Inductor



■ Features

- Closed magnetic circuit avoids crosstalk
- Suitable for high density installation and re-flow soldering
- Sizes 0603 / 0805 / 1206

■ Applications

- Personal Computers
- Portable Equipment
- CD-ROM, Hard Disk, Modem, Printers
- DC-DC Converters
- DSC,DVC,PDA,DVD and HDD

■ Construction

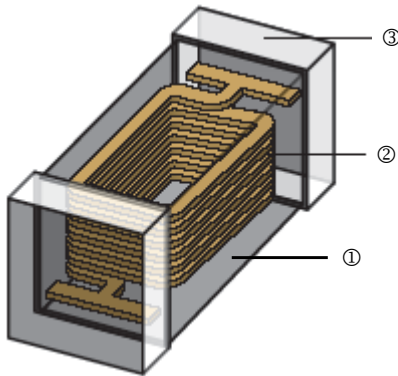

① Ferrite	② Internal Electrode	③ Electrode Plating (Ag/Ni/Sn)
-----------	----------------------	--------------------------------

■ Dimensions

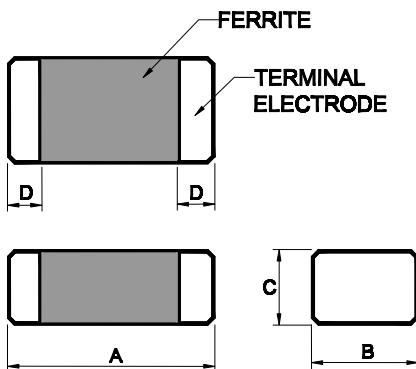

Type	Size (Inch)	A mm	B mm	C mm	D mm	Weight (g) (1000pcs)
ML03	0603	1.60±0.20	0.80±0.20	0.80±0.20	0.30±0.20	6.2
ML05(≤2.2μH)	0805	2.00±0.20	1.25±0.20	0.90±0.20	0.50±0.30	10
ML05(≥2.7μH)	0805	2.00±0.20	1.25±0.20	1.25±0.20	0.50±0.30	10
ML06	1206	3.20±0.20	1.60±0.20	1.10±0.20	0.50±0.30	30
MLH05	0805	2.00±0.20	1.25±0.20	0.90±0.10	0.50±0.20	10
MLH06	0806	2.00±0.15	1.60±0.15	0.90±0.10	0.50±0.20	12
MLH08	1008	2.50±0.20	2.00±0.20	0.90±0.10	0.60±0.20	21

Part Numbering

ML	05	K	T	1R0
Product Type	Dimensions	Inductance Tolerance	Packaging Code	Inductance
ML :Standard MLH :High Current	03: 0603 05: 0805 06: 0806 08: 1008 06: 1206	K: $\pm 10\%$ M: $\pm 20\%$	T: Taping Reel	47N: 47nH R27: 270nH 1R0: 1000nH

Standard Electrical Specifications

ML03 Multilayer Ferrite Chip Inductors Type(□:Tolerance):

Part No.	Inductance (nH)	Tolerance	L/Q Test Condition	Q min.	SRF (MHz) min.	DCR (Ω) max.	IDC (mA) max.
ML03□T47N	47	$\pm 20\%$	50MHz, 200mV	10	260	0.30	50
ML03□T56N	56	$\pm 20\%$	50MHz, 200mV	10	255	0.30	50
ML03□T68N	68	$\pm 20\%$	50MHz, 200mV	10	250	0.30	50
ML03□T82N	82	$\pm 20\%$	50MHz, 200mV	10	245	0.30	50
ML03□TR10	100	$\pm 10, \pm 20\%$	25MHz, 200mV	15	240	0.50	50
ML03□TR12	120	$\pm 10, \pm 20\%$	25MHz, 200mV	15	205	0.50	50
ML03□TR15	150	$\pm 10, \pm 20\%$	25MHz, 200mV	15	180	0.60	50
ML03□TR18	180	$\pm 10, \pm 20\%$	25MHz, 200mV	15	165	0.60	50
ML03□TR22	220	$\pm 10, \pm 20\%$	25MHz, 200mV	15	150	0.80	50
ML03□TR27	270	$\pm 10, \pm 20\%$	25MHz, 200mV	15	136	0.80	50
ML03□TR33	330	$\pm 10, \pm 20\%$	25MHz, 200mV	15	125	0.85	35
ML03□TR39	390	$\pm 10, \pm 20\%$	25MHz, 200mV	15	110	1.00	35
ML03□TR47	470	$\pm 10, \pm 20\%$	25MHz, 200mV	15	105	1.35	35
ML03□TR56	560	$\pm 10, \pm 20\%$	25MHz, 200mV	15	95	1.55	35
ML03□TR68	680	$\pm 10, \pm 20\%$	25MHz, 200mV	15	85	1.70	35
ML03□TR82	820	$\pm 10, \pm 20\%$	25MHz, 200mV	15	75	2.10	35
ML03□T1R0	1000	$\pm 10, \pm 20\%$	10MHz, 200mV	35	65	0.60	25
ML03□T1R2	1200	$\pm 10, \pm 20\%$	10MHz, 200mV	35	60	0.80	25
ML03□T1R5	1500	$\pm 10, \pm 20\%$	10MHz, 200mV	35	55	0.80	25
ML03□T1R5-1	1500	$\pm 10\%$	10MHz, 200mV	35	65	0.80	25
ML03□T1R8	1800	$\pm 10, \pm 20\%$	10MHz, 200mV	35	50	0.95	25
ML03□T2R2	2200	$\pm 10, \pm 20\%$	10MHz, 200mV	35	45	1.55	15
ML03□T2R7	2700	$\pm 10, \pm 20\%$	10MHz, 200mV	35	40	1.35	15
ML03□T3R3	3300	$\pm 10, \pm 20\%$	10MHz, 200mV	35	38	1.55	15
ML03□T3R9	3900	$\pm 10, \pm 20\%$	10MHz, 200mV	35	35	1.70	15
ML03□T4R7	4700	$\pm 10, \pm 20\%$	10MHz, 200mV	35	33	2.10	15
ML03□T5R6	5600	$\pm 10, \pm 20\%$	4MHz, 200mV	35	22	1.55	5
ML03□T6R8	6800	$\pm 10, \pm 20\%$	4MHz, 200mV	35	20	1.70	5
ML03□T8R2	8200	$\pm 10, \pm 20\%$	4MHz, 60 mV	30	18	2.10	5
ML03□T100	10000	$\pm 10, \pm 20\%$	2MHz, 60mV	30	17	1.85	3
ML03□T100-3	10000	$\pm 10, \pm 20\%$	2MHz, 100mV	30	17	1.30	100
ML03□T220	22000	$\pm 10, \pm 20\%$	1MHz, 60mV	15	11	2.10	1

Operating temperature range: -40~+125°C

ML05 Multilayer Ferrite Chip Inductors Type(□:Tolerance):

Part No.	Inductance (nH)	Tolerance	L/Q Test Condition	Q min.	SRF (MHz) min.	DCR (Ω) max.	IDC (mA) max.
ML05□T47N	47	±20%	50MHz, 200mV	20	320	0.20	300
ML05□T56N	56	±20%	50MHz, 200mV	20	320	0.20	300
ML05□T68N	68	±20%	50MHz, 200mV	20	280	0.20	300
ML05□T82N	82	±20%	50MHz, 200mV	20	255	0.20	300
ML05□TR10	100	±10, ±20%	25MHz, 200mV	25	235	0.30	250
ML05□TR12	120	±10, ±20%	25MHz, 200mV	25	220	0.30	250
ML05□TR15	150	±10, ±20%	25MHz, 200mV	25	200	0.40	250
ML05□TR18	180	±10, ±20%	25MHz, 200mV	25	185	0.40	250
ML05□TR22	220	±10, ±20%	25MHz, 200mV	25	170	0.50	250
ML05□TR27	270	±10, ±20%	25MHz, 200mV	25	150	0.50	250
ML05□TR33	330	±10, ±20%	25MHz, 200mV	25	145	0.55	250
ML05□TR39	390	±10, ±20%	25MHz, 200mV	25	135	0.65	200
ML05□TR47	470	±10, ±20%	25MHz, 200mV	25	125	0.65	200
ML05□TR56	560	±10, ±20%	25MHz, 200mV	25	115	0.75	150
ML05□TR68	680	±10, ±20%	25MHz, 200mV	25	105	0.80	150
ML05□TR82	820	±10, ±20%	25MHz, 200mV	25	100	1.00	150
ML05□T1R0	1000	±10, ±20%	10MHz, 200mV	45	75	0.40	50
ML05□T1R2	1200	±10, ±20%	10MHz, 200mV	45	65	0.50	50
ML05□T1R5	1500	±10, ±20%	10MHz, 200mV	45	60	0.50	50
ML05□T1R8	1800	±10, ±20%	10MHz, 200mV	45	55	0.60	50
ML05□T2R2	2200	±10, ±20%	10MHz, 200mV	45	50	0.65	30
ML05□T2R7	2700	±10, ±20%	10MHz, 200mV	45	45	0.75	30
ML05□T3R3	3300	±10, ±20%	10MHz, 200mV	45	41	0.80	30
ML05□T3R9	3900	±10, ±20%	10MHz, 200mV	45	38	0.90	30
ML05□T4R7	4700	±10, ±20%	10MHz, 200mV	45	35	1.00	30
ML05□T5R6	5600	±10, ±20%	4MHz, 200mV	50	32	0.90	15
ML05□T6R8	6800	±10, ±20%	4MHz, 200mV	50	29	1.00	15
ML05□T8R2	8200	±10, ±20%	4MHz, 200mV	50	26	1.10	15
ML05□T100	10000	±10, ±20%	2MHz, 60mV	50	24	1.15	15
ML05□T100-4	10000	±20%	2MHz, 100mV	50	24	0.50	300
ML05□T120	12000	±10, ±20%	2MHz, 60mV	50	22	1.25	15
ML05□T150	15000	±10, ±20%	1MHz, 60mV	30	19	0.80	5
ML05□T180	18000	±10, ±20%	1MHz, 60mV	30	18	0.90	5
ML05□T220	22000	±10, ±20%	1MHz, 60mV	30	16	1.10	5

■ Operating temperature range: -40~+125°C

ML06 Multilayer Ferrite Chip Inductors Type(□:Tolerance):

Part No.	Inductance (nH)	Tolerance	L/Q Test Condition	Q min.	SRF (MHz) min.	DCR (Ω) max.	IDC (mA) max.
ML06□T47N	47	±20%	50MHz, 200mV	20	320	0.15	300
ML06□T56N	56	±20%	50MHz, 200mV	20	280	0.25	300
ML06□T68N	68	±20%	50MHz, 200mV	20	280	0.25	300
ML06□T82N	82	±20%	50MHz, 200mV	20	250	0.25	300
ML06□TR10	100	±10, ±20%	25MHz, 200mV	20	235	0.25	250
ML06□TR12	120	±10, ±20%	25MHz, 200mV	20	220	0.30	250
ML06□TR15	150	±10, ±20%	25MHz, 200mV	20	200	0.30	250
ML06□TR18	180	±10, ±20%	25MHz, 200mV	20	185	0.40	250
ML06□TR22	220	±10, ±20%	25MHz, 200mV	20	170	0.40	250
ML06□TR27	270	±10, ±20%	25MHz, 200mV	20	150	0.50	250
ML06□TR33	330	±10, ±20%	25MHz, 200mV	20	145	0.60	250
ML06□TR39	390	±10, ±20%	25MHz, 200mV	25	135	0.50	200
ML06□TR47	470	±10, ±20%	25MHz, 200mV	25	125	0.60	200
ML06□TR56	560	±10, ±20%	25MHz, 200mV	25	115	0.70	150
ML06□TR68	680	±10, ±20%	25MHz, 200mV	25	105	0.80	150
ML06□TR82	820	±10, ±20%	25MHz, 200mV	25	100	0.90	150
ML06□T1R0	1000	±10, ±20%	10MHz, 200mV	45	75	0.40	100
ML06□T1R2	1200	±10, ±20%	10MHz, 200mV	45	65	0.50	100
ML06□T1R5	1500	±10, ±20%	10MHz, 200mV	45	60	0.50	80
ML06□T1R8	1800	±10, ±20%	10MHz, 200mV	45	55	0.50	70
ML06□T2R2	2200	±10, ±20%	10MHz, 200mV	45	50	0.60	60
ML06□T2R7	2700	±10, ±20%	10MHz, 200mV	45	45	0.60	60
ML06□T3R3	3300	±10, ±20%	10MHz, 200mV	45	41	0.70	60
ML06□T3R9	3900	±10, ±20%	10MHz, 200mV	45	38	0.80	50
ML06□T4R7	4700	±10, ±20%	10MHz, 200mV	45	35	0.90	50
ML06□T5R6	5600	±10, ±20%	4MHz, 200mV	45	32	0.70	25
ML06□T6R8	6800	±10, ±20%	4MHz, 200mV	45	29	0.80	25
ML06□T8R2	8200	±10, ±20%	4MHz, 200mV	45	26	0.90	25
ML06□T100	10000	±10, ±20%	2MHz, 60mV	45	24	1.00	25
ML06□T120	12000	±10, ±20%	2MHz, 60mV	45	22	1.05	15
ML06□T150	15000	±10, ±20%	1MHz, 60mV	35	19	0.70	5
ML06□T180	18000	±10, ±20%	1MHz, 60mV	35	18	0.75	5
ML06□T220	22000	±10, ±20%	1MHz, 60mV	35	16	0.90	5
ML06□T270	27000	±10, ±20%	1MHz, 60mV	35	14	0.90	5
ML06□T330	33000	±10, ±20%	1MHz, 60mV	35	13	1.05	5
ML06□T470	47000	±20%	2MHz, 100mV	40	10	3.40	10

■ Operating temperature range: -40~+125°C

High Current Electrical Specifications

MLH05 Multilayer Ferrite Chip Inductors Type(□:Tolerance):

Part No.	Inductance (uH)	Tolerance	Test Condition	SRF (MHz) min.	DCR (Ω) max.	IDC (mA) max.
MLH05□TR47	0.47	±20%	1MHz, 250mV	100	0.125	1100
MLH05□TR68	0.68	±20%	1MHz, 250mV	100	0.150	1000
MLH05□TR82	0.82	±20%	1MHz, 250mV	90	0.175	900
MLH05□T1R0	1.0	±20%	1MHz, 250mV	90	0.200	800
MLH05□T1R2	1.2	±20%	1MHz, 250mV	80	0.200	800
MLH05□T1R5	1.5	±20%	1MHz, 250mV	70	0.275	700
MLH05□T1R8	1.8	±20%	1MHz, 250mV	60	0.275	700
MLH05□T2R2	2.2	±20%	1MHz, 250mV	50	0.313	600
MLH05□T3R3	3.3	±20%	1MHz, 250mV	40	0.275	500
MLH05□T4R7	4.7	±20%	1MHz, 250mV	30	0.375	500

■Operating temperature range: -40~+125°C

MLH06 Multilayer Ferrite Chip Inductors Type(□:Tolerance):

Part No.	Inductance (uH)	Tolerance	Test Condition	SRF (MHz) min.	DCR (Ω) max.	IDC (mA) max.
MLH06□TR47	0.47	±20%	1MHz, 250mV	100	0.182	1500
MLH06□TR68	0.68	±20%	1MHz, 250mV	90	0.195	1500
MLH06□TR82	0.82	±20%	1MHz, 250mV	80	0.208	1500
MLH06□T1R0	1.0	±20%	1MHz, 250mV	60	0.208	1400
MLH06□T1R2	1.2	±20%	1MHz, 250mV	60	0.208	1400
MLH06□T1R5	1.5	±20%	1MHz, 250mV	50	0.260	1200
MLH06□T1R8	1.8	±20%	1MHz, 250mV	50	0.260	1200
MLH06□T2R2	2.2	±20%	1MHz, 250mV	40	0.286	1200
MLH06□T3R3	3.3	±20%	1MHz, 250mV	30	0.312	1100
MLH06□T4R7	4.7	±20%	1MHz, 250mV	20	0.390	1100

■Operating temperature range: -40~+125°C

MLH08 Multilayer Ferrite Chip Inductors Type(□:Tolerance):

Part No.	Inductance (uH)	Tolerance	Test Condition	SRF (MHz) min.	DCR (Ω) Max.	IDC (mA) max.
MLH08□TR47	0.47	±20%	1MHz, 250mV	100	0.088	1800
MLH08□TR68	0.68	±20%	1MHz, 250mV	90	0.113	1700
MLH08□TR82	0.82	±20%	1MHz, 250mV	80	0.125	1700
MLH08□T1R0	1.0	±20%	1MHz, 250mV	60	0.138	1600
MLH08□T1R2	1.2	±20%	1MHz, 250mV	60	0.138	1600
MLH08□T1R5	1.5	±20%	1MHz, 250mV	50	0.163	1500
MLH08□T1R8	1.8	±20%	1MHz, 250mV	50	0.163	1500
MLH08□T2R2	2.2	±20%	1MHz, 250mV	40	0.213	1300
MLH08□T3R3	3.3	±20%	1MHz, 250mV	30	0.200	1200
MLH08□T4R7	4.7	±20%	1MHz, 250mV	25	0.250	1100

■Operating temperature range: -40~+125°C

■ Environmental Characteristics

Electrical Performance Test

Item	Requirement	Test Method
Inductance	Refer to standard electrical characteristic spec.	HP4291B
Q		HP4291B
SRF		HP4291B
DC Resistance RDC		Agilent 34401A
IDC		The DC current value having temperature increased 40 °C after thru DC current 2 hours at ambient temperature

Mechanical Performance Test

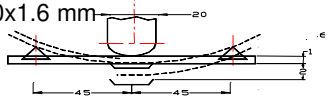
Item	Requirement	Test Method
Resistance to Soldering Heat	Appearance: No damage More than 75% of the terminal. Electrode should be covered with solder.	Pre-heating: 150°C, 1min. Solder Composition: Sn/Ag3.0/Cu0.5 (Pb-Free) Solder Temperature: 260±5°C (Pb-Free) Immersion Time: 10±1 sec.
Solderability	The electrodes shall be at least 90% covered with new solder coating	Pre-heating: 150°C, 1min. Solder Composition: Sn/Ag3.0/Cu0.5 (Pb-Free) Solder Temperature: 245±5°C (Pb-Free) Immersion Time: 4±1 sec.
Flexure Strength	The forces applied on the right conditions must not damage the terminal electrode and the ferrite.	Test device shall be soldered on the substrate Substrate Dimension: 100x40x1.6 mm Deflection: 2.0 mm Keeping Time: 30 sec. 
Vibration		*For 0402, substrate dimension is 100x40x0.8 mm Test device shall be soldered on the substrate Oscillation Frequency: 10 to 55 to 10Hz for 1 min. Amplitude: 1.5 mm Time: 2 hrs for each axis (X, Y & Z), total 6 hrs

Climatic Test

Item	Requirement	Test Method															
Damp Heat with Load	Appearance: No damage L change: within±20% of initial value	Temperature: 40±2°C Relative Humidity: 90 ~ 95% Time: 1000 hrs Measured after exposure in the room condition for 24 hrs															
Temperature Cycle		One cycle: <table border="1"> <thead> <tr> <th>Step</th> <th>Temperature (°C)</th> <th>Time (min.)</th> </tr> </thead> <tbody> <tr> <td>1</td> <td>-40±3</td> <td>30</td> </tr> <tr> <td>2</td> <td>25±2</td> <td>3</td> </tr> <tr> <td>3</td> <td>85±3</td> <td>30</td> </tr> <tr> <td>4</td> <td>25±2</td> <td>3</td> </tr> </tbody> </table> Total: 100 cycles Measured after exposure in the room condition for 24 hrs	Step	Temperature (°C)	Time (min.)	1	-40±3	30	2	25±2	3	3	85±3	30	4	25±2	3
Step		Temperature (°C)	Time (min.)														
1		-40±3	30														
2	25±2	3															
3	85±3	30															
4	25±2	3															
High Temperature Resistance	Temperature: 85±3°C Relative Humidity: 20% Applied Current: Rated Current Time: 1000 hrs Measured after exposure in the room condition for 24 hrs																
Low Temperature Resistance	Temperature: -40±3°C Relative Humidity: 0% Time: 1000 hrs Measured after exposure in the room condition for 24 hrs																

■ Storage Temperature: 15~28°C; Humidity < 80%RH

■Packaging

Reel Specifications

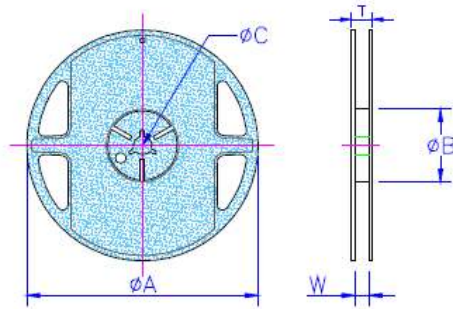

Type	A mm	B mm	C mm	W mm	T mm	Quantity (EA)	
						Paper Tape (Type B)	Polystyrene Tape (Type A)
ML03	178±1	60.0+0.5	13.0±0.2	9.00±0.5	12.0±0.15	4,000	-
ML05(≤2.2uH)	178±1	60.0+0.5	13.0±0.2	9.00±0.5	12.0±0.15	4,000	-
ML05(≥2.7uH)	178±1	60.0+0.5	13.0±0.2	9.00±0.5	12.0±0.15	-	3,000
ML06	178±1	60.0+0.5	13.0±0.2	9.00±0.5	12.0±0.15	-	3,000
MLH05	178±1	60.0+0.5	13.0±0.2	9.00±0.5	12.0±0.15	4,000	-
MLH06	178±1	60.0+0.5	13.0±0.2	9.00±0.5	12.0±0.15	-	3,000
MLH08	178±1	60.0+0.5	13.0±0.2	9.00±0.5	12.0±0.15	-	3,000

Tape Specifications

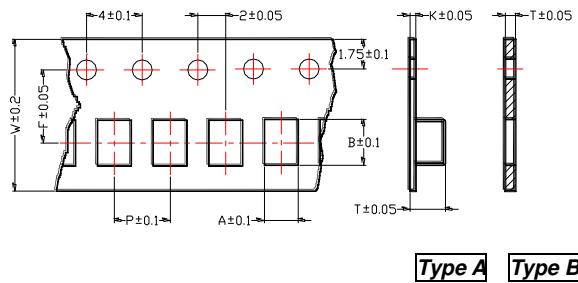

Tape Material

Carrier tape: Polystyrene for 0805(≤2.2uH) 1206

Paper for 0603 0805(≥2.7uH)

Cover type : Polystyrene

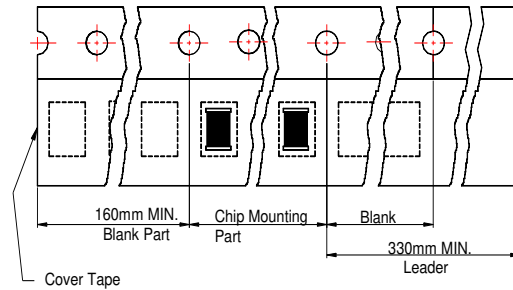

Type	A mm	B mm	T mm	W mm	P mm	F mm	K mm	Tape Type
ML03	1.05	1.85	0.95	8.0	4.0	3.5	-	B
ML05(≤2.2uH)	1.50	2.42	0.95	8.0	4.0	3.5	-	B
ML05(≥2.7uH)	1.50	2.35	1.45	8.0	4.0	3.5	0.22	A
ML06	1.88	3.50	1.27	8.0	4.0	3.5	0.22	A
MLH05	1.45	2.25	0.95	8.0	4.0	3.5	-	B
MLH06	1.88	2.40	1.23	8.0	4.0	3.5	0.23	A
MLH08	2.20	2.85	1.40	8.0	4.0	3.5	0.23	A

- Note:**
1. Please make sure that your product is has been evaluated and confirmed against your specifications when our product is mounted to your product.
 2. Do not knock nor drop.
 3. All the items and parameters in this product specification have been prescribed on the premise that our product is used for the purpose, under the condition and in the environment agreed upon between you and us. You are requested not to use our product deviating from such agreement.