

THIS DRAWING IS UNPUBLISHED. RELEASED FOR PUBLICATION
 © COPYRIGHT BY TYCO ELECTRONICS CORPORATION. ALL RIGHTS RESERVED.

LOC	DIST	REVISIONS					
DF	X0	P	LTR	DESCRIPTION	DATE	DWN	APVD
		B		REV PER ECO 08-018955	06NOV08	PK	DW

COMPONENT	MATERIAL	FINISH
HOUSING MOUNTING NUT CLAMP NUT	STAINLESS STEEL PER ASTM-A484 AND ASTM- A582, TYPE 303	PASSIVATE PER ASTM-A-380
DIELECTRIC	TFE FLUOROCARBON PER ASTM-D-1457	N/A
CENTER CONTACT	BERYLLIUM COPPER PER ASTM-B-196 OR ASTM-B-197, ALLOY C17300, CONDITION H	GOLD PLATE PER ASTM-B-488
SHRINK TUBING	HEAT SHRINKABLE POLYOLEFIN COMPOUND MIL-I-23053/4	N/A
CRIMP SLEEVE	COPPER OR BRASS ALLOY ROCKWELL F65 MAX	GOLD PLATE PER ASTM-B-488

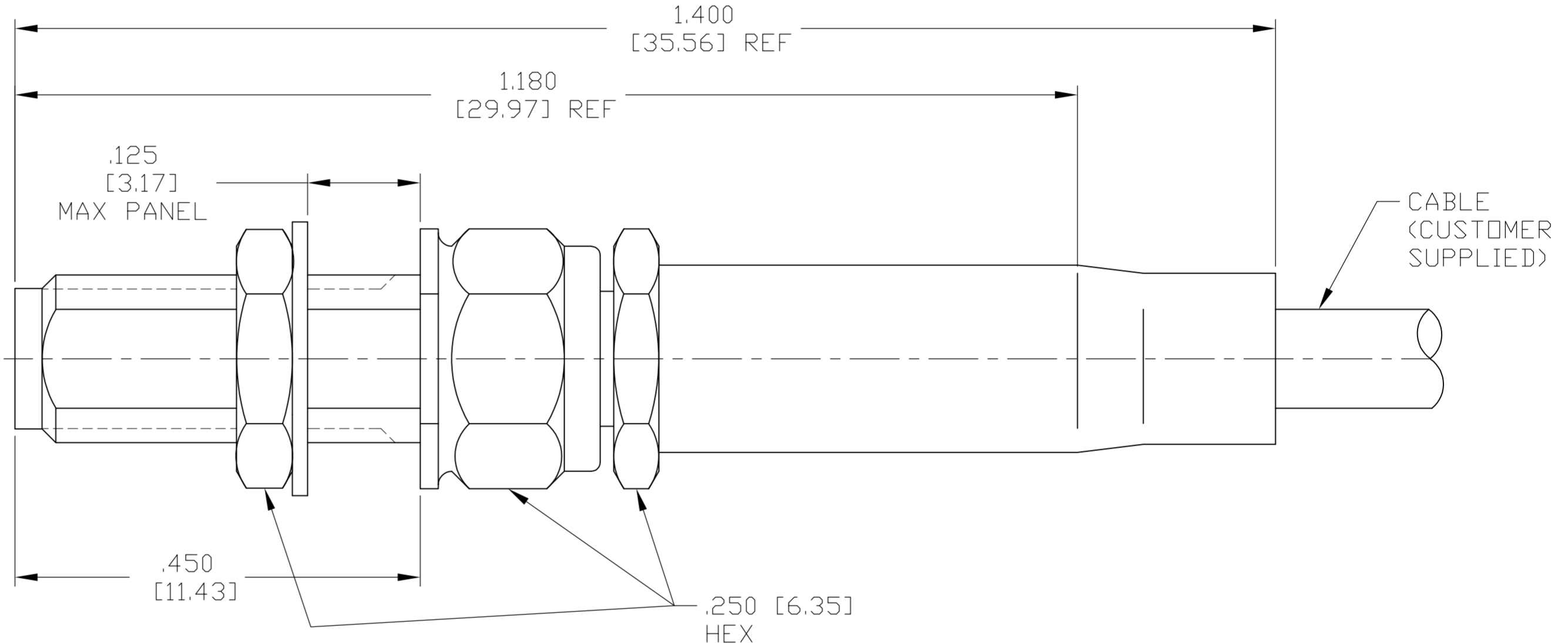
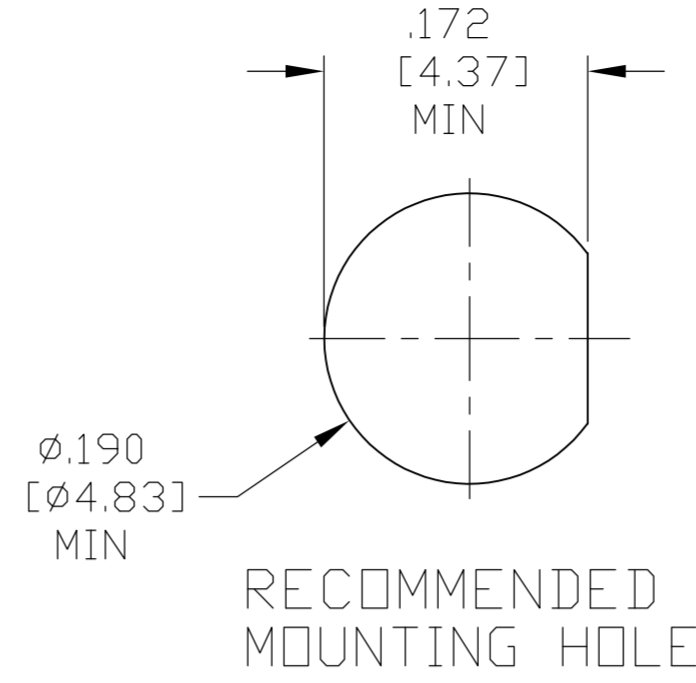

ELECTRICAL	MECHANICAL	ENVIRONMENTAL
Nominal Impedance (Ohms) <u>50</u>	Interface Dimensions MIL-STD-348A, Fig. 319-2	TEMPERATURE RATING <u>-65°C TO +165°C</u>
MAX Frequency Range (GHz) DC to <u>3 GHz</u>	Recommended Mating Torque <u>5 In. Lbs.</u>	Vibration MIL-STD-202, Method 204, Condition D
Volt Rating (VRMS MAX) @ Sea Level <u>250</u>	Mating Characteristics: Insertion (MAX Lbs) <u>3</u>	Shock MIL-STD-202, Method 213, Condition I
VSWR <u>1.24 MAX</u>	Withdrawal (MIN Oz) <u>1</u>	Thermal Shock MIL-STD-202, Method 107, Condition B, EXCEPT HIGH TEMP <u>-85°C</u>
Insertion Loss (dB MAX) <u>.04 √fGHz</u>	Force to Engage and Disengage (In-Lbs MAX) <u>2.0</u>	Moisture Resistance MIL-STD-202, Method 106
RF Leakage (dB MIN) <u>-60</u>	Center Contact Captivation Axial (Lbs) <u>6.0</u>	Corrosion - MIL-STD-202, Method 101, Condition B, 5% salt spray
Corona, 70,000 Ft (VRMS MIN) <u>190</u>	Cable Retention Axial Force (Lbs) <u>20</u>	
Dielectric Withstanding Voltage (VRMS MIN) @ Sea Level <u>750</u>	Torque (In-Oz) <u>N/A</u>	
Contact Resistance (Milliohms MAX) Center Contact <u>4.0</u>		
Outer Contact <u>2.0</u>		
Cable to Housing <u>0.5</u>		
RF High Potential @ Sea Level (VRMS MIN @ 5 MHz) <u>500</u>		
I.R.(Megohms MIN) <u>5,000</u>		

DESIGNED FOR USE WITH RG174/U,188,& 316	
CABLE ENTRY DIAMETER MINIMUM	
SLEEVE	.063 [1.70]
CONTACT	.024 [0.61]
DIELECTRIC	.066 [1.68]

THIS DRAWING IS A CONTROLLED DOCUMENT.		DWN C.C.THOMAS 2-11-08	Tyco Electronics Corporation Harrisburg, PA 17105-3608
DIMENSIONS: INCHES [mm]		CHK D.WILSON 2-11-08	
TOLERANCES UNLESS OTHERWISE SPECIFIED:		APVD D.WILSON 2-11-08	NAME SSMA BULKHEAD FEEDTHROUGH CABLE JACK-CRIMP ATTACHMENT
		PRODUCT SPEC APPLICATION SPEC 408-4784	SIZE A2
MATERIAL SEE TABLE		FINISH SEE TABLE	CAGE CODE 00779
		WEIGHT 2.4 Grams	DRAWING NO 1757804
		CUSTOMER DRAWING	
		SCALE 8:1	SHEET 1 of 1
		REV B	RESTRICTED TO -

1757804-1
PART NUMBER