

LOC		DIST		REVISIONS			
GP	00	REV	DATE	BY	CHK	APPV	
R		REVISED PER EC 0515-0061-05	27 APR 05	AWF	AWF		
R1		REVISED PER ECO-09-021826	OBJAN10	KK	AEG		

- ① HOUSING: GLASS FILLED POLYESTER; COLOR: BLACK.
- ② CONTACT: PHOSPHOR BRONZE.
- ③ NICKEL UNDERPLATE: 0.00127 [.000050] MIN - ALL OVER.
- ④ TIN-LEAD PLATE: 0.00254 [.000100] MIN - SOLDER POSTS.
- ⑤ GOLD PLATE: 0.00038 [.000015] MIN - CONTACT AREA.
- ⑥ NICKEL PLATE PER MIL-G-45204. GOLD PLATE PER QQ-N-290.
- ⑦ AMP PART NUMBER AND DATE CODE ARE MARKED IN APPROXIMATE AREA SHOWN, EITHER SIDE.
- ⑧ RECOMMENDED PCB FINISHED HOLE DIA: 1.07±0.08 [.042±.003].
- ⑨ OBSOLETE PARTS: OBSOLETE CIS STREAMLINING PER D.RENAUD/D.SINISI

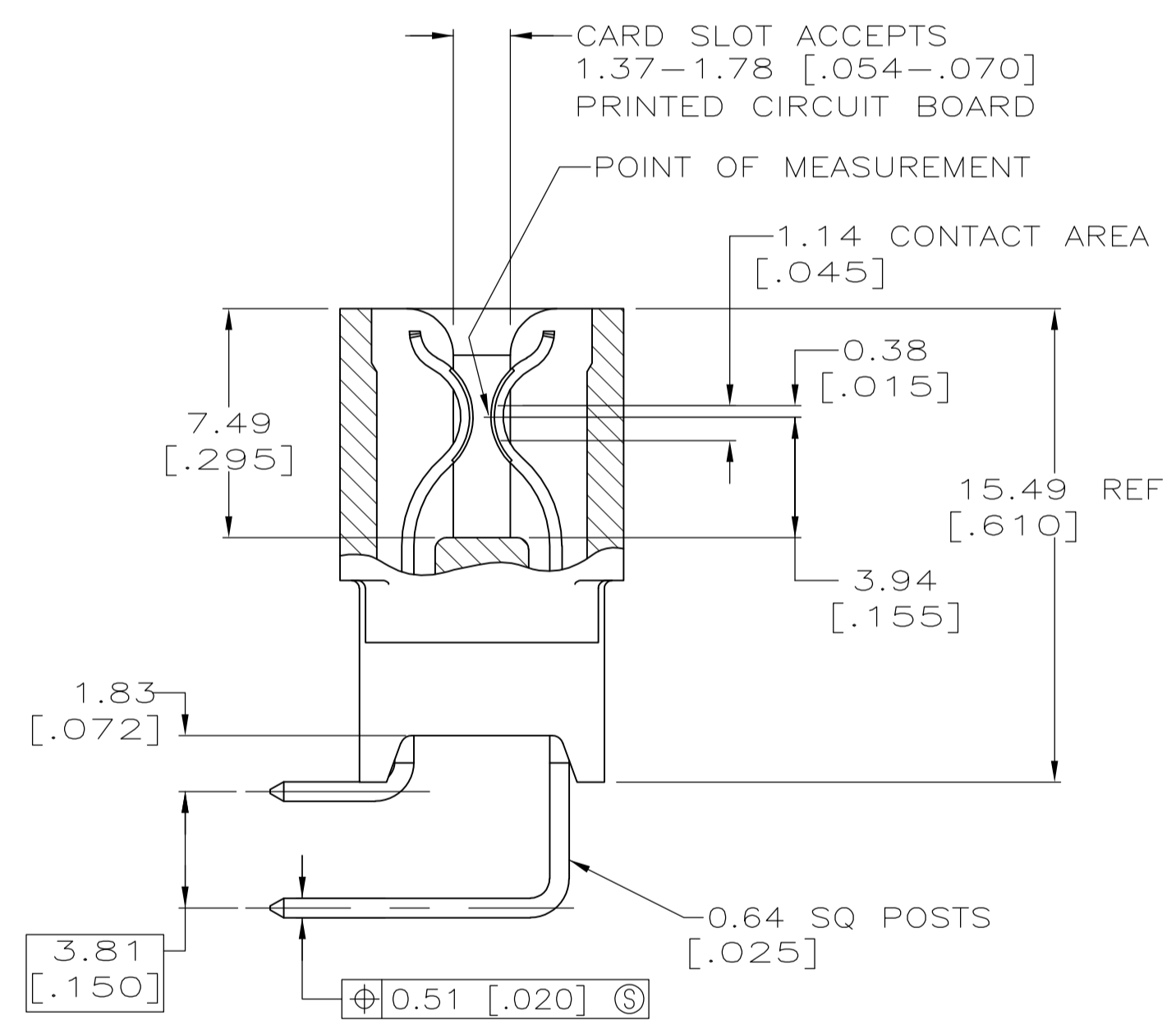
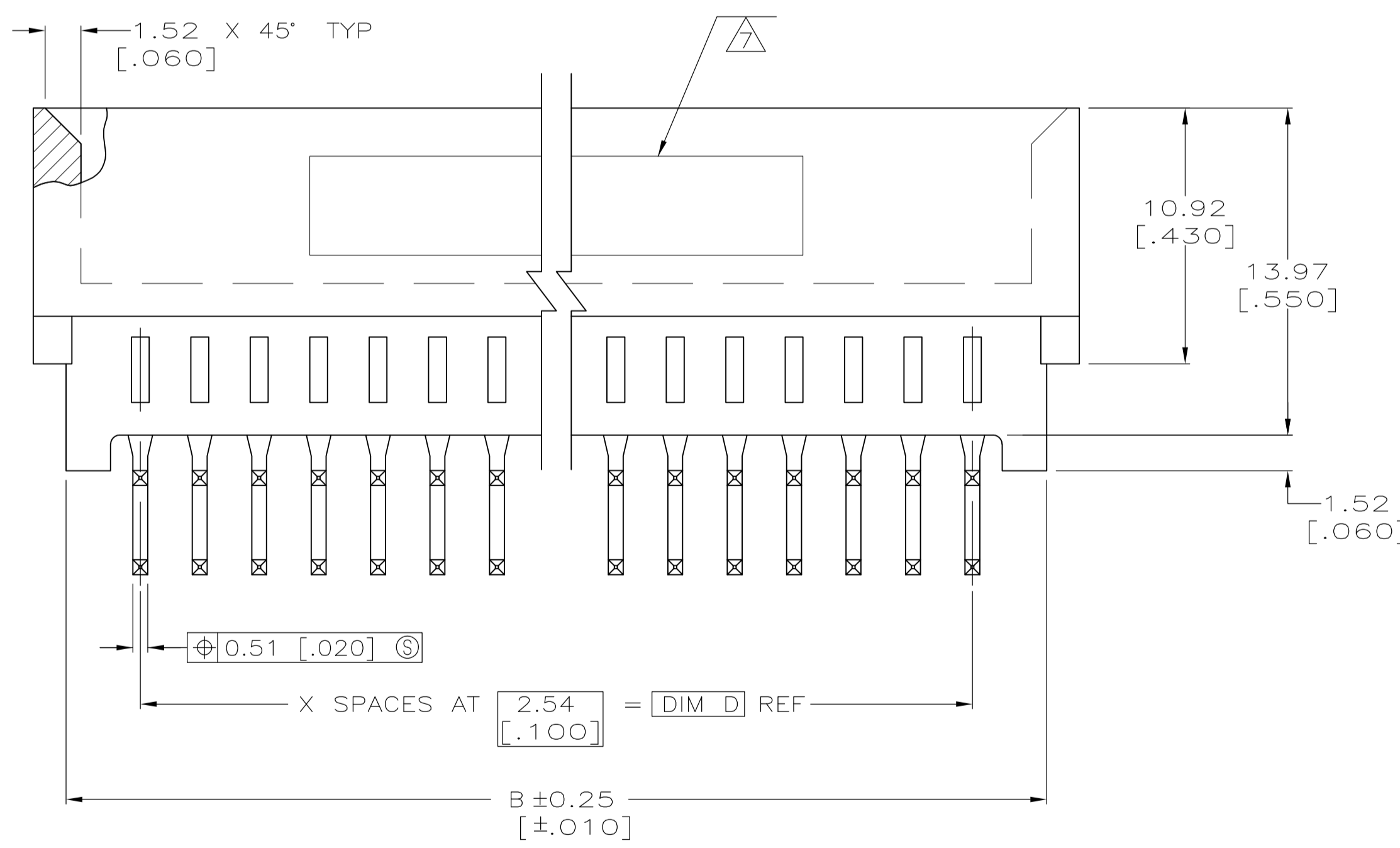
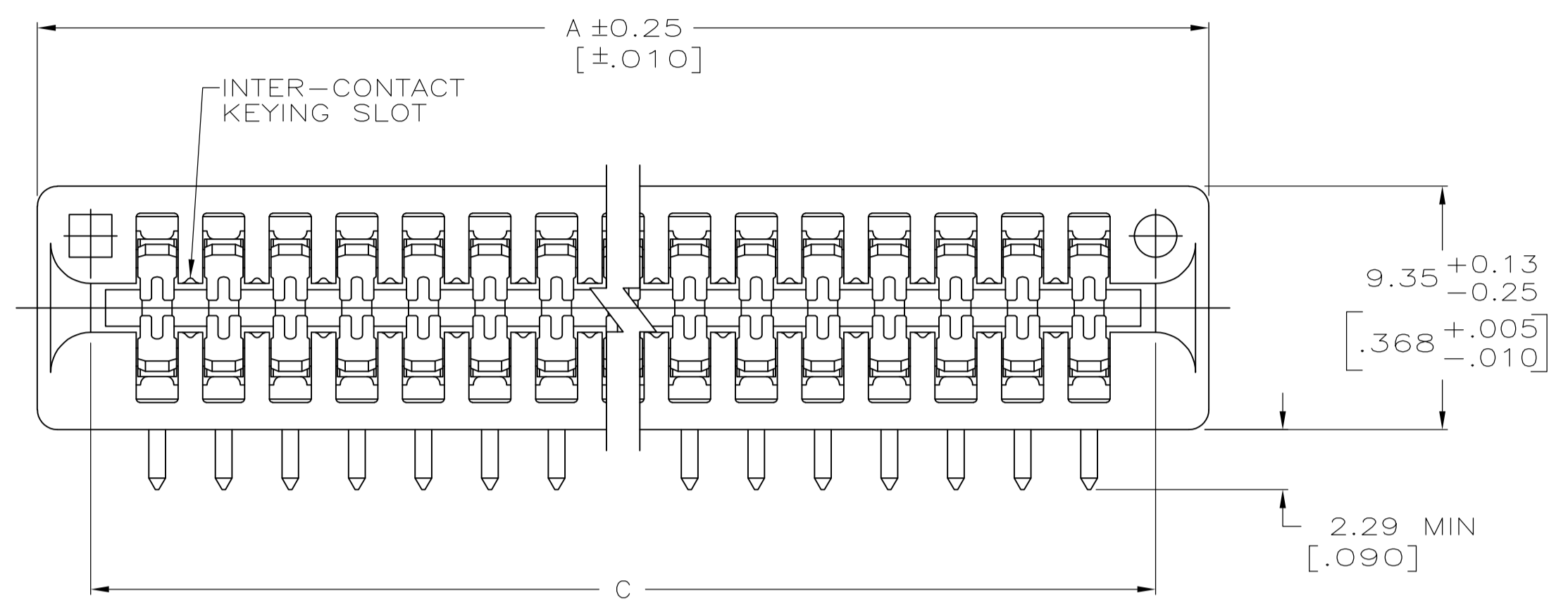

⑨	SUPERSEDED BY 5532600-6	45.72 [1.800]	50.80 [2.000]	52.07 [2.050]	54.864 [2.160]	18	19	532600-6
		78.74 [3.100]	83.82 [3.300]	85.09 [3.350]	87.88 [3.460]	31	32	532600-5
		76.20 [3.000]	81.28 [3.200]	82.55 [3.250]	85.34 [3.360]	30	31	532600-4
⑨	OBSOLETE BY 5532600-2	60.96 [2.400]	66.04 [2.600]	67.31 [2.650]	70.10 [2.760]	24	25	532600-2
		-	-	-	-	-	50	532600-3
		-	-	-	-	-	18	532600-1
		D	C	B	A	X	NO OF POSN	PART NUMBER

THIS DRAWING IS A CONTROLLED DOCUMENT.

DIMENSIONS: mm TOLERANCES UNLESS OTHERWISE SPECIFIED: 0 PLC ± - 1 PLC ± - 2 PLC ± 0.13 [.005] 3 PLC ± - 4 PLC ± - ANGLES ± °	DWN: R. SHIREY/UTA 10/30/91 CHK: J. DIORAZIO 2-27-92 APVD: M. THUMMA 2-27-92 NAME: M. THUMMA PRODUCT SPEC: 108-9039 APPLICATION SPEC:	Tyco Electronics Corporation Harrisburg, Pa 17105-3608 CONNECTOR ASSEMBLY, STANDARD EDGE II, 2.54 [.100]
MATERIAL: ①② FINISH: ③④⑤⑥	SIZE: A1 CAGE CODE: 00779 DRAWING NO: 532600 WEIGHT:	RESTRICTED TO: - SCALE: 5:1 SHEET: 1 OF 1 REV: R1

CUSTOMER DRAWING