

DCNEV250 SERIES HIGH CURRENT HIGH VOLTAGE DC CONTACTOR RELAY



Specifications Overview

Amperage:	250A Continuous Carry
Housing:	Nylon UL 94-V0
Voltage Rating:	900V
Output Connectors:	M8 x 1.25 High Current Connections
Connectors:	Wire Leads for Control Circuit
Ingress Protections:	IP67
Operating Temperature:	-40°C to 85°C
Circuitry:	SPST NO
Coil Voltage:	M: 12-24V DC Nominal, 9-36V DC Working F: 72V DC Nominal, 48-95V DC Working G: 48-72V DC Nominal, 32-95V DC Working
Max Coil Inrush Current:	0.7-3.8A
Mounting:	#10 with Compression Limiters
Size:	Reference Dimensions on Page 2
Mounting Bolt Torque:	1.7-3.3 Nm (15-30 in-lb)
Contact Torque:	8.8-11 Nm (80-100 in-lb)
Terminals:	M8 Silver Plated Copper
Approvals:	UL File No. E510407 Recognized

Description

High current and high voltage DC contactor relays for electric vehicle applications such as charging station, battery power supply, DC power control, circuit protection, and other switch controls. Can also be used in uninterruptible power supply and other electronic control systems. Are available with polarized and non-polarized contacts to best suit electrical systems' polarity. The Coil Economizer greatly reduces coil power and heating after the contactor is energized. Once the contactor is energized, it takes minimal coil power to keep the contacts closed due to Pulse Width Modulation (PWM) reducing the average power delivered by pulsing the electrical signal.

Applications

- Battery Electric Vehicles
- Hybrid Electric Vehicles
- Material Handling
- Electric Maintenance and Transport Vehicles
- Industrial Applications

Ordering Information

Please see page 2 for more information

Features and Benefits

- High current (250A) and high voltage (900V) contactor for EV applications
- Compact structure, helping reduce noise when turned on
- Coil Economizer greatly reduces coil power and heating
- Sealed IP67, gas-filled relay which mitigates arcing
- No mounting orientation restrictions
- Designed and manufactured under the IATF16949 certification for Automotive Quality Systems.
- Designed specifically for automotive applications.



Web Resources

Download 2D print and technical resources at:
littelfuse.com/DCNEV250

DCNEV250 SERIES HIGH CURRENT HIGH VOLTAGE DC CONTACTOR

Ordering Information

PART NUMBER	DESCRIPTION	COIL VOLTAGE 12-24V DC	COIL VOLTAGE 72V DC	COIL VOLTAGE 48-72 VDC	BOTTOM MOUNT	AUXILIARY CONTACT SPST-NO	AUXILIARY CONTACT SPST-NC	NON-POLARIZED TERMINALS	POTTED PCB
DCNEV250-M	High Voltage DC Contactor Relay Bottom Mount with Polar Load Terminals	●			●				
DCNEV250-MN	High Voltage DC Contactor Relay Bottom Mount with Non-Polar Load Terminals	●			●			●	
DCNEV250-MA	High Voltage DC Contactor Relay Bottom Mount with Auxiliary Circuit with Polar Load Terminals	●			●	●			
DCNEV250-MAN	High Voltage DC Contactor Relay Bottom Mount with Auxiliary Circuit & Non-Polar Load Terminals	●			●	●		●	
DCNEV250-MP	High Voltage DC Contactor Relay Bottom Mount with Potted PCB with Polar Load Terminals	●			●				●
DCNEV250-MB	High Voltage DC Contactor Relay Bottom Mount with Auxiliary Circuit with Polar Load Terminals	●			●		●		
DCNEV250-F	High Voltage DC Contactor Relay Bottom Mount with Polar Load Terminals		●		●				
DCNEV250-FA	High Voltage DC Contactor Relay Bottom Mount with Auxiliary Circuit with Polar Load Terminals		●		●	●			
DCNEV250-FAN	High Voltage DC Contactor Relay Bottom Mount with Auxiliary Circuit & Non-Polar Load Terminals		●		●	●		●	
DCNEV250-FB	High Voltage DC Contactor Relay Bottom Mount with Auxiliary Circuit with Polar Load Terminals		●		●		●		
DCNEV250-FN	High Voltage DC Contactor Relay Bottom Mount with Non-Polar Load Terminals		●		●			●	
DCNEV250-G	High Voltage DC Contactor Relay Bottom Mount with Polar Load Terminals			●	●				
DCNEV250-GA	High Voltage DC Contactor Relay Bottom Mount with Auxiliary Circuit with Polar Load Terminals			●	●	●			
DCNEV250-GAN	High Voltage DC Contactor Relay Bottom Mount with Auxiliary Circuit & Non-Polar Load Terminals			●	●	●		●	
DCNEV250-GB	High Voltage DC Contactor Relay Bottom Mount with Auxiliary Circuit with Polar Load Terminals			●	●		●		
DCNEV250-GN	High Voltage DC Contactor Relay Bottom Mount with Non-Polar Load Terminals			●	●			●	

* Box Packaging Available

DCNEV250 SERIES HIGH CURRENT HIGH VOLTAGE DC CONTACTOR

Dimensions in MM

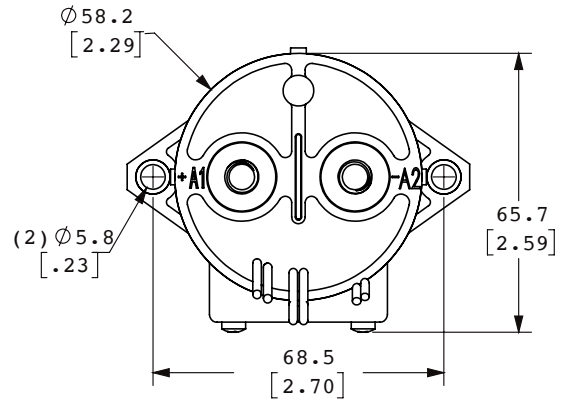
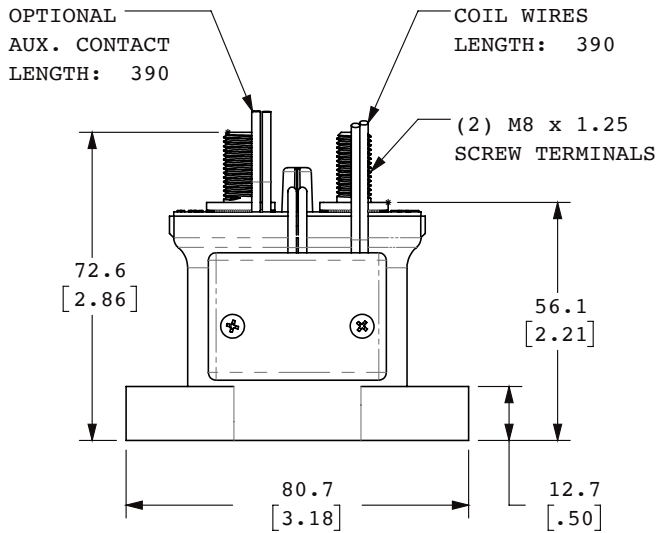

Estimated Make Break Chart

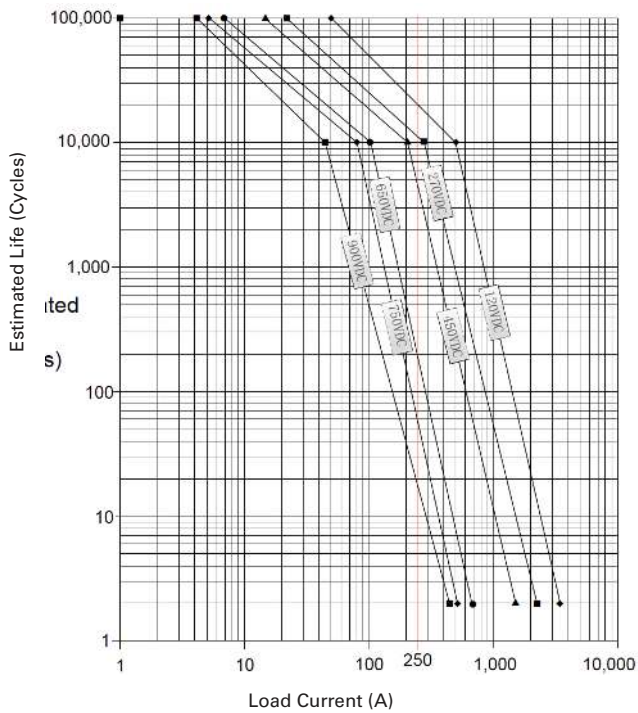

Electrical Load Life Ratings for Typical EV Applications

MAKE/BREAK LIFE CAPACITIVE & RESISTIVE LOADS AT 320VDC¹

@90% pre-charge (make only), see chart below	50,000 cycles
@Min 80% pre-charge (make only), see chart below	50 cycles

¹: Resistive load includes L=25uH. Load @2500A, test @200uH

Capacitive Make Test Curve

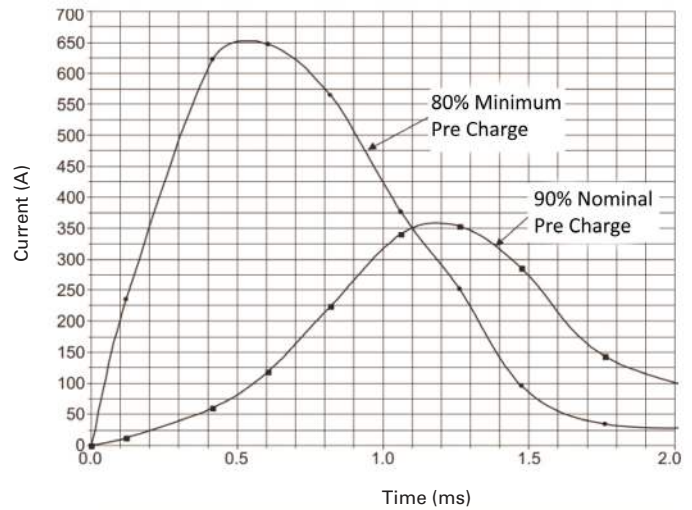

Electrical Diagram

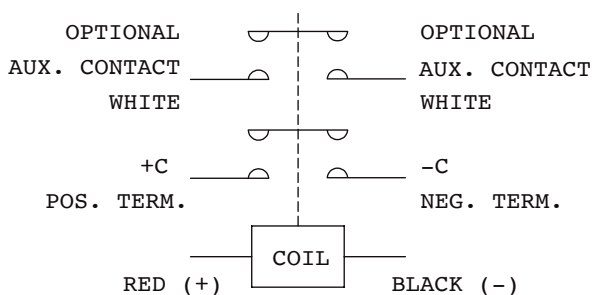

Estimated Electrical Life

	POLARITY SENSITIVE TYPE		NON-POLARITY SENSITIVE TYPE	
Voltage (V)	450	650	650	450
Current(A)	250	250	100	100
Life (cycles)	5,000	500	1,000	10,000

Note:

Estimates based on extrapolated data. User is encouraged to confirm performance in application.

DCNEV250 SERIES HIGH CURRENT HIGH VOLTAGE DC CONTACTOR

Performance Data

MAIN CONTACT	
Contact arrangement	1 Form X (SPST-NO, DM)
Rated Operating Voltage	12-900VDC
Continuous (Carry) Current	250A (65°C) *2
Max short circuit current	2,000A @320VDC, 1 cycle*1
Dielectric Withstanding Voltage	2,200Vrms (leakage <1mA)
Insulation Resistance	Terminal to Terminal/Terminal to coil New: Min 100 MΩ @500Vdc End of life: Min 50 MΩ @500Vdc
Voltage Drop (@250A)	≤50mV

1: Does not meet dielectric & IR after test.
2: Higher currents are possible but are relevant to cross-sectional area of conductor.

COIL DATA			
Coil Voltage	12 - 24Vdc	72Vdc	48 - 72Vdc
Voltage (Max.)	36Vdc	95Vdc	95Vdc
Pickup voltage (Max.)	9Vdc	48Vdc	32Vdc
Dropout voltage (Min.)	6Vdc	27Vdc	18Vdc
Inrush Current (Max.)	3.8A	0.7A	1.3A
Holding Current (Avg.)	0.13A@12Vdc / 0.07A@24Vdc	0.02A@72Vdc	0.03A@48Vdc

MAX. BREAKING LIMIT	MAX. SHORT CIRCUIT
2,000A @ 320VDC, 1 cycle	3,000A, 1 sec

Current vs Time Curve

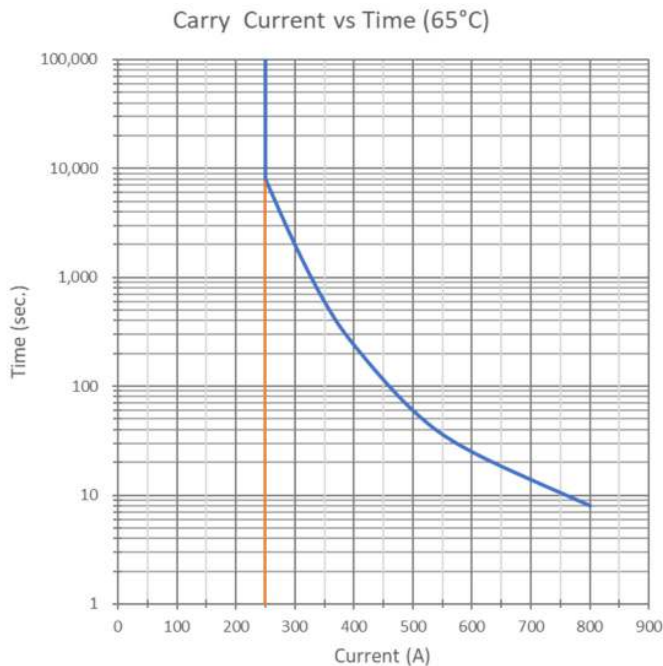

Copper Conductor: 75mm²

LIFE	
Resistive load life	See estimated make break chart
Mechanical life	200,000 cycles

OPERATE / RELEASE TIME	
Close (includes bounce)	25ms, Max.
Release	12ms, Max.

ENVIRONMENTAL DATA	
Shock, 11ms ½ sine, operating	20G Peak
Vibration, Sine, Peak, 20G	80—2,000Hz
Operating Ambient Temperature	-40 to +85°C
Weight	0.95 Lb (0.43 kg)
Altitude	<4000m

AUX. CONTACT	
Aux. Contact Arrangement	1 Form A, 1 Form B
Aux. Contact Current Max	2A@30VDC/ 3A@125VAC
Aux. Contact Current Min	100mA@8V
Max. Contact Resistance	0.417Ω@30VDC 0.150Ω@125VAC

Application Note:

- Be sure to use washer to prevent screws from loosening. Tighten the screw torque range is specified as below. Exceeding the maximum torque can lead to product rupture.
 - Contact torque (M8): 80 - 100 lb.in (8.8 - 11 N.m)
 - Mounting torque: 15 - 30 lb.in (1.7 - 3.3 N.m)
- Please refer to drawing for polarity sensitive type during connecting; No orientation for non-polar type.
- Do not use dropped products.
- Avoid to install the product in a strong magnetic field (Close to the transformer or magnet), or near an object with heat radiation.
- Electrical life
Please use under load capability and life cycle so as not to cause a function failure. (Please also treat the contactor as a product with specified life and replace it when necessary). It is possible to make parts burn around the contactor once operating failure happens. So it is necessary to take layout into account to make sure power shall be cut off within 1 second.
- Lifetime of internal gas diffusion
The contactor is sealed and filled with gas, lifetime of gas diffusion is determined by temperature in contact chamber (Ambient temperature + Temperature rising by contact energizing). Therefore environment temperature should be from -40 to +85°C.
- Do not let particle and oil stain on the main terminal with which the load shall make a reliable contact. Or it will cause a lot of heat.