

THIS DRAWING IS UNPUBLISHED. RELEASED FOR PUBLICATION
 © COPYRIGHT - By - ALL RIGHTS RESERVED.

REVISIONS					
P	LTR	DESCRIPTION	DATE	DWN	APVD
G		REVISED PER ECO-16-005106	05APR2016	NK	MZ
H		REVISED PER ECO-17-013721	15NOV2017	RS	MZ

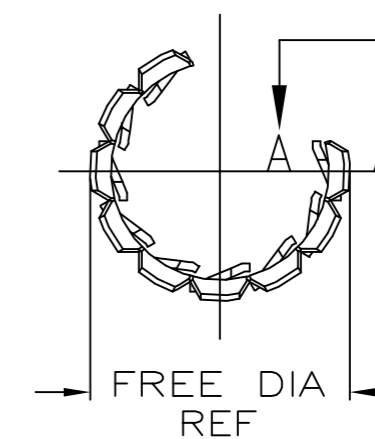
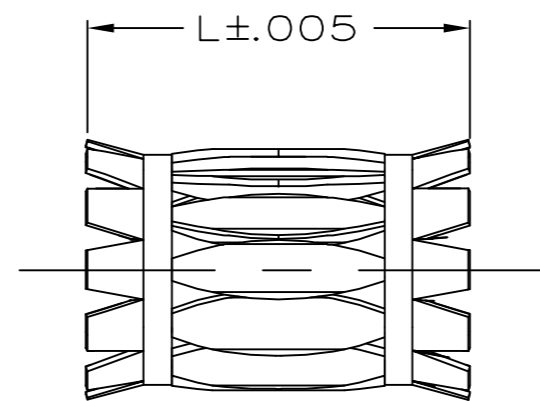
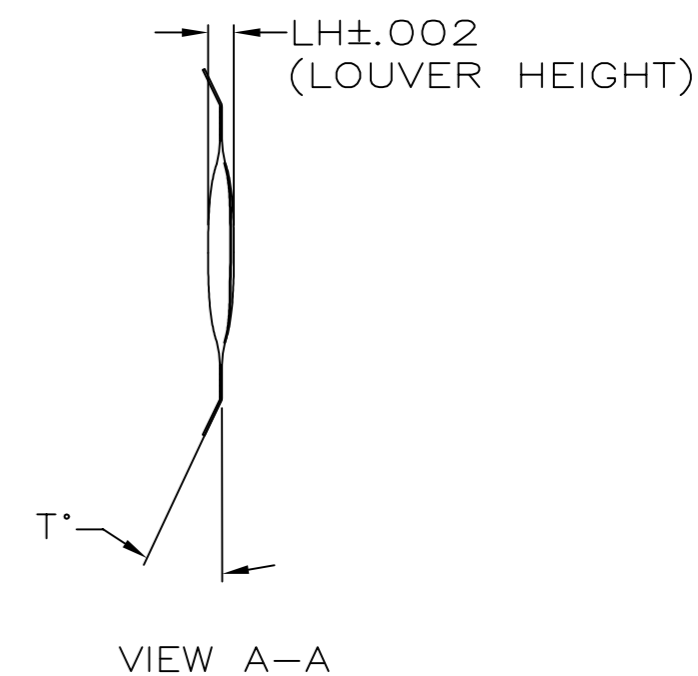

1. FINISH: GOLD PLATE 10uIN MIN THICK.
2. FINISH: NICKEL PLATE 40uIN MIN THICK.
3. FINISH: GOLD PLATE 30uIN MIN THICK.
4. FINISH: SILVER PLATE 500uIN MIN THICK.
5. FINISH: SILVER PLATE 200uIN MIN THICK.
6. PLATING NOTES ARE TO BE INTERPRETED AS FOLLOWS, 4-2 AS 4 OVER 2.
7. MATERIAL: CDA172, BeCu.
8. MATERIAL: STAINLESS STEEL.
9. FINISH: GOLD PLATE 50uIN MIN THICK.

10 PRELIMINARY PART NUMBER.

11 OBSOLETE PARTS: OBSOLETE CIS STREAMLINING PER D.RENAUD/D.SINISI

T	L	LH	(FREE DIA)	MAT'L (NOTE)	MATING PIN Ø REF	PLATING NOTE NO.	NUM LOUV	MAT'L THK	REF	PART NO.						
15°	.690	[.050]	[0.69]	6	12.7	[.500]	9-2	16	0.15	[.006]	--	5-192033-3	OBSOLETE			
15°	.690	[.052]	[1.18]	6	--		PREPL	32	0.20	[.008]	--	5-192033-2				
15°	.690	[.052]	[4.00]	7	--		5-2	150	0.20	[.008]	--	5-192033-1	OBSOLETE 11			
45°	.700	[.052]	[.95]	7	--		5-2	25	0.20	[.008]	--	5-192033-0	OBSOLETE			
15°	.69	[.052]	[.90]	7	--		5-2	22	0.20	[.008]	--	4-192033-9				
15°	.69	[.052]	[.55]	7	--		5-2	13	0.20	[.008]	--	4-192033-8	OBSOLETE 11			
15°	.69	[.050]	[3.00]	7	26.21	[1.032]	UNPL	41	0.10	[.004]	--	4-192033-7				
15°	.69	[.050]	[.99]	7	20.32	[.800]	UNPL	26	0.15	[.006]	--	4-192033-6				
15°	.69	[.050]	[1.35]	7	28.57	[1.125]		5	35	0.10	[.004]	--	4-192033-5	OBSOLETE		
45°	.70	[.050]	[4.00]	7	44.45	[1.750]		5	55	0.15	[.006]	--	4-192033-4	OBSOLETE		
45°	.70	[.050]	[.95]	7	20.06	[.790]	--	25	0.15	[.006]	01321	4-192033-3	OBSOLETE			
45°	.70	[.050]	[3.00]	7	34.92	[1.375]		5	44	0.15	[.006]	01230	4-192033-2	OBSOLETE		
15°	.69	[.050]	[3.00]	7	34.92	[1.375]		5	44	0.15	[.006]	01229	4-192033-1			
15°	.69	[.050]	[3.00]	7	34.92	[1.375]		5	44	0.10	[.004]	01199	4-192033-0			
15°	.69	[.050]	[3.00]	7	33.40	[1.315]		5	42	0.15	[.006]	01233	3-192033-9			
											01306	3-192033-8				
15°	.69	[.050]	[3.00]	7	32.25	[1.270]	4-2	41	0.15	[.006]	01262	3-192033-7	OBSOLETE			
15°	.69	[.050]	[3.00]	7	32.25	[1.270]		5	41	0.15	[.006]	01260	3-192033-6			
15°	.69	[.050]	[1.02]	7	22.22	[.875]	UNPL	27	0.15	[.006]	--	3-192033-5				
15°	.69	[.050]	[1.50]	7	31.75	[1.250]		5	39	0.15	[.006]	01232	3-192033-4	OBSOLETE		
15°	.69	[.050]	[3.00]	7	30.15	[1.187]		5	L	0.15	[.006]	01192	3-192033-3	OBSOLETE 11		
15°	.69	[.050]	[2.50]	7	26.21	[1.032]	4-2	32	0.10	[.004]	01261	3-192033-2	OBSOLETE			
OBSOLETE											--	3-192033-1	OBSOLETE			
15°	.69	[.050]	[2.50]	7	26.21	[1.032]		5	32	0.10	[.004]	01185	3-192033-0	OBSOLETE 11		
15°	.69	[.050]	[2.50]	7	26.21	[1.032]	UNPL	32	0.10	[.004]	01265	2-192033-9				
45°	.70	[.050]	[1.18]	7	25.40	[1.000]		5	32	0.15	[.006]	01179	2-192033-8	OBSOLETE		
15°	.69	[.050]	[1.15]	8	25.40	[1.000]	UNPL	31	0.15	[.006]	01269	2-192033-7				
15°	.69	[.050]	[1.15]	7	25.40	[1.000]		5	31	0.15	[.006]	01175	2-192033-6			
OBSOLETE											01174	2-192033-5	OBSOLETE			
15°	.69	[.050]	[1.15]	7	24.13	[.950]	UNPL	31	0.15	[.006]	01173	2-192033-4	OBSOLETE 11			
15°	.69	[.050]	[1.11]	7	23.36	[.920]		5	30	0.15	[.006]	--	2-192033-3	OBSOLETE		
15°	.69	--	--	--	--	--	--	--	--	--	01254	2-192033-2	OBSOLETE			
15°	.69	[.052]	[1.05]	7	22.22	[.875]		5	28	0.20	[.008]	01168	2-192033-1	OBSOLETE 11		
15°	.69	[.050]	[1.05]	7	22.22	[.875]		5	28	0.15	[.006]	01167	2-192033-0			
15°	.69	[.050]	[1.02]	7	22.22	[.875]	3-2	27	0.15	[.006]	01310	1-192033-9				
											01250	1-192033-8	SUPERSEDED 11			
OBSOLETE											01251	1-192033-7	OBSOLETE			
OBSOLETE											01253	1-192033-6	OBSOLETE			
15°	.69	[.050]	[2.00]	7	22.22	[.875]		5	27	0.10	[.004]	01257	1-192033-5	OBSOLETE 11		
15°	.69	[.050]	[1.02]	7	22.22	[.875]	UNPL	27	0.10	[.004]	01256	1-192033-4	OBSOLETE			
											01267	1-192033-3	OBSOLETE			
											01204	1-192033-2	OBSOLETE 11			
											01166	1-192033-1	OBSOLETE			
15°	.69	[.050]	[1.02]	7	21.38	[.842]		5	27	0.15	[.006]	01164	1-192033-0	OBSOLETE		
15°	.69	[.050]	[.99]	7	21.38	[.842]		5	26	0.15	[.006]	01287	192033-9	OBSOLETE 11		
15°	.69	[.050]	[.95]	7	20.62	[.812]		5	25	0.15	[.006]	01252	192033-8	OBSOLETE		
OBSOLETE			[.99]	7	20.32	[.800]	1-2	26	0.15	[.006]	01239	192033-7	OBSOLETE			
15°	.69	[.052]	[.95]	7	20.0	[.787]		5	25	0.20	[.008]	01161	192033-6	OBSOLETE 11		
15°	.69	[.050]	[.95]	7	20.0	[.787]		5	25	0.15	[.006]	01314	192033-5	OBSOLETE		
											01156	192033-4	OBSOLETE 11			
15°	.69	[.052]	[.92]	7	19.05	[.750]		5	24	0.20	[.008]	01155	192033-3	OBSOLETE		
15°	.69	[.052]	[.92]	7	19.05	[.750]	UNPL	24	0.20	[.008]	01224	192033-2	OBSOLETE 11			
15°	.69	[.052]	[.90]	7	19.05	[.750]		5	23	0.20	[.008]	01249	192033-1	OBSOLETE		

THIS DRAWING IS A CONTROLLED DOCUMENT.		DWN RA JAYNE 07-24-92	TE Connectivity	
DIMENSIONS: INCHES		CHK -	NAME CONTACT BAND,FEMALE	
TOLERANCES UNLESS OTHERWISE SPECIFIED:		APVD -	PRODUCT SPEC -	
0 PLC ± -		PRODUCT SPEC -	APPLICATION SPEC -	
1 PLC ± -		ANGLE ± -	WEIGHT -	
2 PLC ± 0.25[.01]		FINISH -	SIZE A2	CAGE CODE 00779
3 PLC ± 0.125[.005]			DRAWING NO C=192033	RESTRICTED TO -
4 PLC ± -			SCALE NTS	SHEET 1 OF 1
MATERIAL SEE TABLE			CUSTOMER DRAWING	REV H