



SPECIFICATION SHEET

SPECIFICATION SHEET NO.	N0924- SOT233400SA09T
DATE	Sept. 24, 2021
REVISION	A2
DESCRIPTION	<p>SMD Plastic-Encapsulate MOSFETS, SOT-23 series, 3 pads</p> <p>AO3400 -5.8AType, 30V N-Channel enhancement Mode Field effect Transistor Continuous Drain Current: 5.8A,</p> <p>Maximum Power Dissipation: 1.5W</p> <p>Operating Temp. Range -50°C ~+150°C,</p> <p>Package in Tape/Reel, 3000pcs/Reel</p> <p>RoHS/RoHS III compliant</p>
CUSTOMER	
CUSTOMER PART NUMBER	
CROSS REF. PART NUMBER	
ORIGINAL PART NUMBER	MDD AO3400 -5.8A
PART CODE	SOT233400SA09T

VENDOR APPROVE			
Issued/Checked/Approved			
DATE: Sept. 24, 2021			

CUSTOMER APPROVE	
DATE:	

SMD PLASTIC-ENCAPSULATE MOSFETS SOT-23 SERIES

MAIN FEATURE

- High dense cell design for extremely low RDS(ON)
- Exceptional on-resistance and maximum DC current capability



APPLICATION

- Load Switch for Portable Devices
- DC/DC Converter

RFQ

[Request For Quotation](#)

PART CODE GUIDE

SOT23	3400	S	A09T
1	2	3	4

- 1) **SOT23**: SMD Plastic-Encapsulate MOSFETS, SOT-23 series, 3 pads
- 2) **3400**: Type code for Original part number AO3400-5.8A
- 3) **S**: Package code, Package in Tape/Reel, 3000pcs/Reel
- 4) **A09T**: Marking code for “A09T” on the case surface, Different Marking for different specification.

SMD PLASTIC-ENCAPSULATE MOSFETS SOT-23 SERIES

DIMENSION (Unit: Inch/mm)

Image for reference

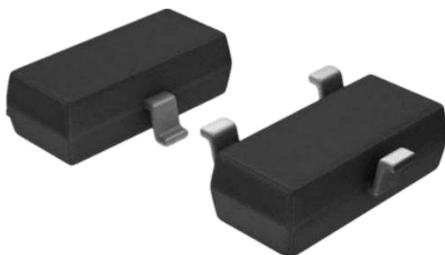

Marking: A09T

SOT-23

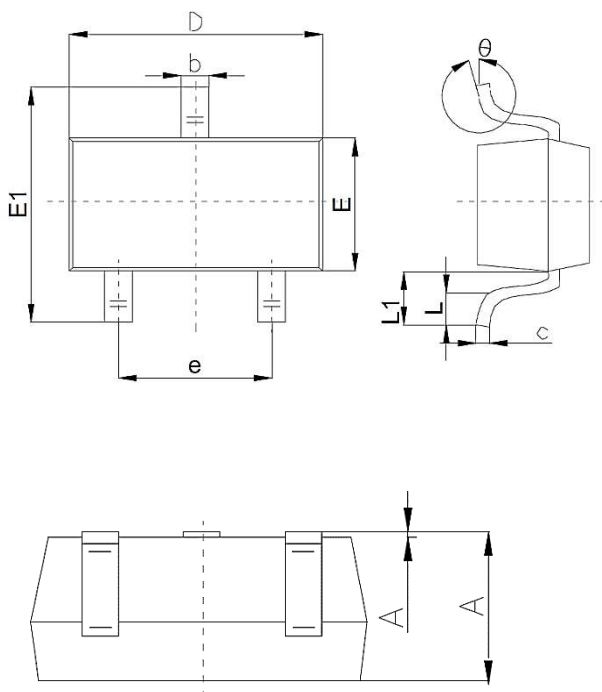

Symbol	Value (mm)		
	Min.	Typ.	Max.
A	1.0		1.4
A1			0.10
b	0.35		0.50
c	0.10		0.20
D	2.70	2.90	3.10
E	1.40		1.60
E1	2.40		2.80
e		1.9	
L	0.10		0.30
L1	0.40		
θ	0°		10°

**Recommend Pad Layout
(Tol.: +/-0.05mm)**

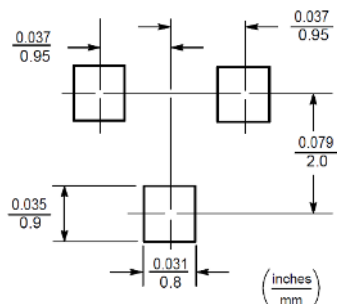

Equivalent Circuit Diagram

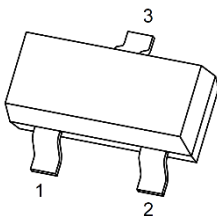

- 1. Gate
- 2. Source
- 3. Drain

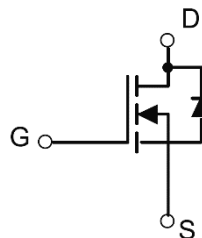

SMD PLASTIC-ENCAPSULATE MOSFETS SOT-23 SERIES
30V N-CHANNEL MODE MOSFET

V (BR)DSS	R DS(on) Typical	I D MAX
30V	27mΩ@4.5V	5.8A
	29mΩ@3.3V	5.8A

MECHANICAL DATA

V(BR)DSS	Terminals	Polarity	Mounting Position	Weight per piece
JEDEC SOT-23 molded plastic body	Matte tin plated	Polarity symbol marking on case	Any	0.00019 Ounce, 0.00591 grams

MAX. RATINGS & THERMAL CHARACTERISTICS AT Ta=25 °C (unless otherwise specified)

Parameter	SYMBOLS	VALUE	UNITS
		LIMIT	
Drain-Source Breakdown Voltage	V (BR)DSS	30	V
Gate-Source Voltage	V GS	+/-12	V
Continuous Drain Current	I D	5.8	A
		4.6	
Power Dissipation	P D	1.5	W
		0.9	
Pulsed Drain Current Note 1	I DM	23	A
Operating Junction Temperature	T J	+150	°C
Storage Temperature Range	T STG	-50 ~ +150	°C
Thermal Resistance Junction-Ambient	R ΘJA	100	°C/W

Notes

- 1) Repeat rating : Pulse width limited by junction temperature.
- 2) Surface Mounted on FR4 Board, t ≤5 sec.

SMD PLASTIC-ENCAPSULATE MOSFETS SOT-23 SERIES
MOSFET ELECTRICAL CHARACTERISTICS AT Ta=25 °C (unless otherwise specified)

Parameter	SYMBOLS	VALUE			UNIT	Condition
		Min.	Typ.	Max.		
Drain-source Breakdown Voltage	V (BR) DSS	30			V	V GS=0V I D= -250μA
Zero Gate Voltage Drain Current	I DSS)			1	μA	V DS=-24V, V GS=0V
				100		V DS=-24V, V GS=0V
Gate-source Leakage Current	I GSS			+/-100	nA	V GS=+/-12V, V DS=0V
Gate threshold voltage	V GS(th)	0.5	0.8	1.2	V	V GS= 5V, I D=250μA
Drain-source on-resistance (note 1)	R DS(on)		27	32	mΩ	V GS=4.5V, I D= 5.8A
			29	45		V GS=3.3V, I D=4.0A
			35	50		V GS=2.5V, I D=2.0A
Forward transconductance	g FS	8			S	V DS=5V, I D=5A

DYNAMIC ELECTRICAL CHARACTERISTICS (See Note 2)

Parameter	SYMBOLS	VALUE			UNIT	Condition
		Min.	Typ.	Max.		
Input Capacitance	C iss		635		pF	V DS= 15V V GS=0V f =1MHz
Output Capacitance	C oss		135			
Reverse Transfer Capacitance	C rss		40			
Total Gate Charge	Q g		10.5		nC	V DS= 15V I D=5A V GS =4.5V
Gate Source Charge	Q g		1.6			
Gate Drain Charge	Q g		2.7			

Note:

- 1) Pulse test: pulse width ≤ 300μs, duty cycle ≤ 2%
- 2) Guaranteed by design, not subject to production testing.

SMD PLASTIC-ENCAPSULATE MOSFETS SOT-23 SERIES
SWITCHING CHARACTERISTICS (SEE NOTE 2)

Parameter	SYMBOLS	VALUE			UNIT	Condition
		Min.	Typ.	Max.		
Turn on Delay Time	$t_{d(on)}$		7.5		ns	$V_{DD} = -15V$ $I_D = 5.0A$ $R_G = 3.3 \Omega$ $V_{GS} = 4.5V$
Turn on Rise Time	t_r		18			
Turn Off Delay Time	$t_{d(off)}$		36			
Turn Off Fall Time	t_f		5			

SOURCE DRAIN DIODE CHARACTERISTIC

Parameter	SYMBOLS	VALUE			UNIT	Condition
		Min.	Typ.	Max.		
Source drain current (Body Diode)	I_{SD}			1.5	A	$T_C = 25^\circ C$
Diode forward voltage (See note 1)	V_{SD}		0.82	1.2	V	$I_S = 3A$ $V_{GS} = 0V$

Note:

- 1) Pulse test: pulse width $\leq 300\mu s$, duty cycle $\leq 2\%$
- 2) Guaranteed by design, not subject to production testing.

SMD PLASTIC-ENCAPSULATE MOSFETS SOT-23 SERIES
RELIABILITY

Number	Experiment Items	Experiment Method And Conditions	Reference Documents
1	Solder Resistance Test	Test 260°C± 5°C for 10 ± 2 sec. Immerse body into solder 1/16" ± 1/32"	MIL-STD-750D METHOD-2031.2
2	Solderability Test	230°C ±5°C for 5 sec.	MIL-STD-750D METHOD-2026.1 0
3	Pull Test	1 kg in axial lead direction for 10 sec.	MIL-STD-750D METHOD-2036.4
4	Bend Test	0.5Kg Weight Applied To Each Lead, Bending Arcs 90 °C ± 5 °C For 3 Times	MIL-STD-750D METHOD-2036.4
5	High Temperature Reverse Bias Test	TA=100°C for 1000 Hours at VR=80% Rated VR	MIL-STD-750D METHOD-1038.4
6	Forward Operation Life Test	TA=25°C Rated Average Rectified Current	MIL-STD-750D METHOD-1027.3
7	Intermittent Operation Life Test	On state: 5 min with rated IRMS Power Off state: 5 min with Cool Forced Air. On and off for 1000 cycles.	MIL-STD-750D METHOD-1036.3
8	Pressure Cooker Test	15 PSIG, TA=121°C, 4 hours	MIL-S-19500 APPENOIXC
9	Temperature Cycling Test	-55°C~+125°C; 30 Minutes For Dwelled Time 5 minutes for transferred time. Total: 10 cycles.	MIL-STD-750D METHOD-1051.7
10	Thermal Shock Test	0°C for 5 minutes., 100°C for 5minutes, Total: 10 cycles	MIL-STD-750D METHOD-1056.7
11	Forward Surge Test	8.3ms Single Sale Sine-wave One Surge.	MIL-STD-750D METHOD-4066.4
12	Humidity Test	TA=65°C, RH=98% for 1000 hours.	MIL-STD-750D METHOD-1021.3
13	High Temperature Storage life Test	150°C for 1000 Hours	MIL-STD-750D METHOD-1031.5

SMD PLASTIC-ENCAPSULATE MOSFETS SOT-23 SERIES

SUGGESTED REFLOW PROFILE (For Reference Only)

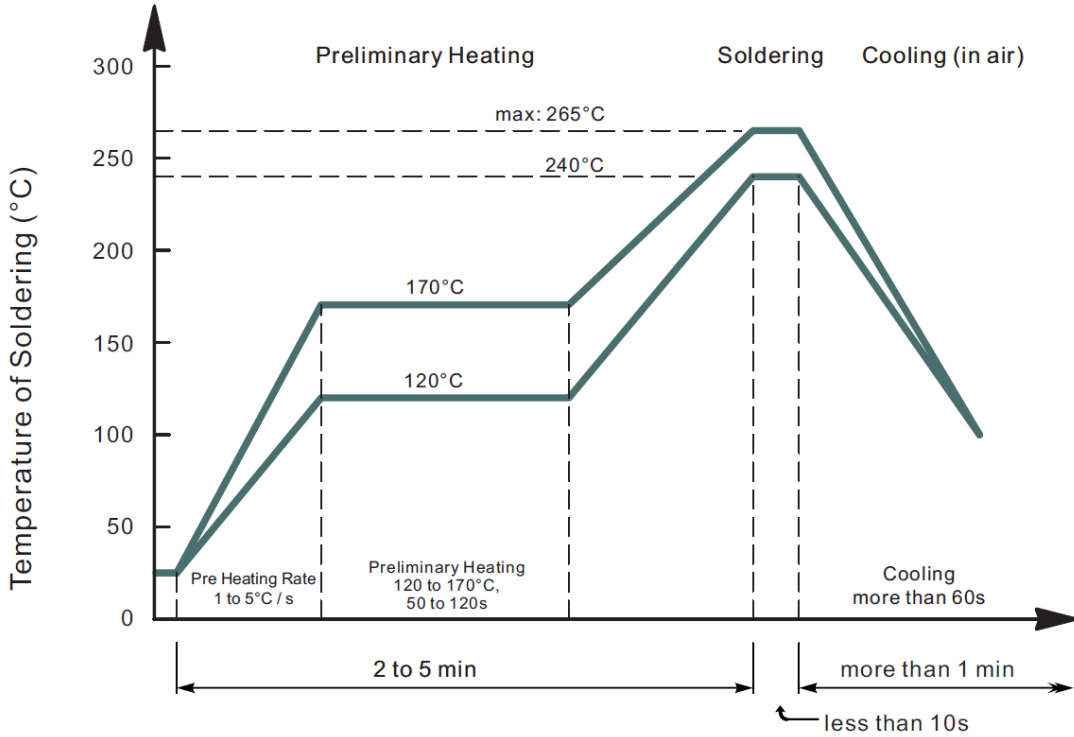

- Recommended peak temperature is over 245°C, If peak temperature is below 245 °C, you may adjust the following parameters; time length of peak temperature (longer), time length of soldering (longer), thickness of solder paste (thicker)
- Welding shall not exceed 2 times
- Remark: lead free solder paste (96.5 sn/3.0 Ag/0.5Cu)

SMD PLASTIC-ENCAPSULATE MOSFETS SOT-23 SERIES

RATINGS AND CHARACTERISTIC CURVES (For Reference Only)

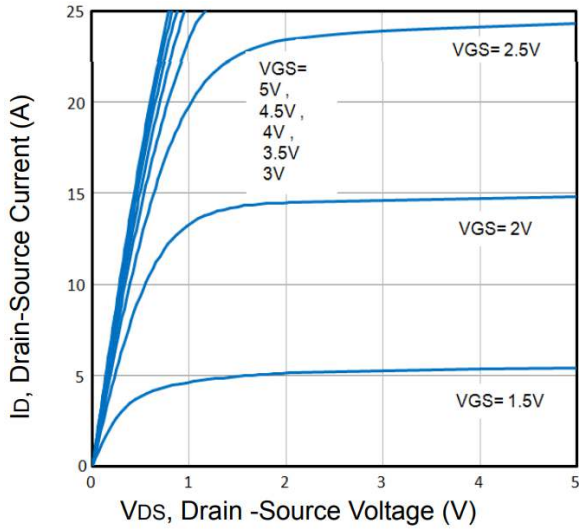

Fig1. Typical Output Characteristics

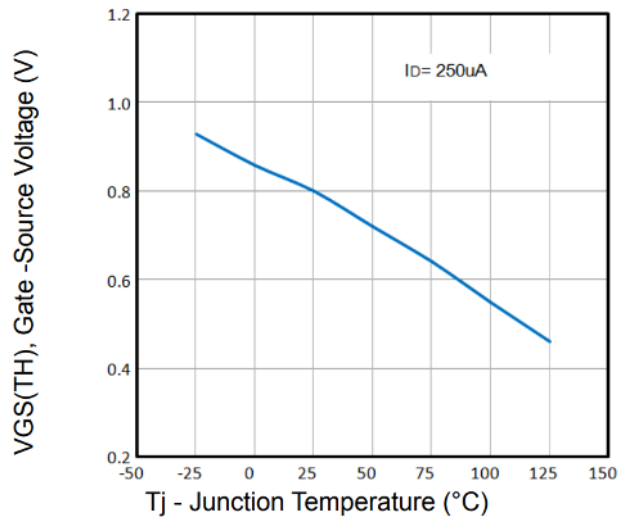

Fig2. Normalized Threshold Voltage Vs. Temperature

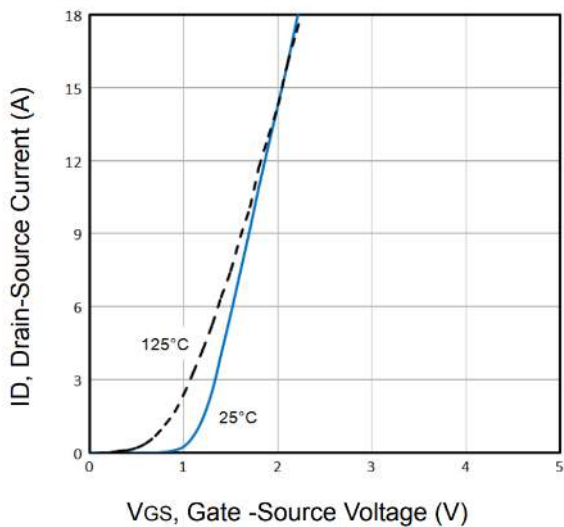

Fig3. Typical Transfer Characteristics

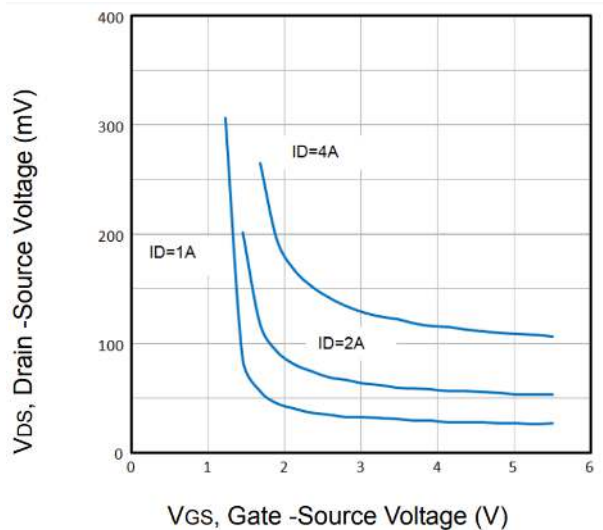

Fig4. Drain-Source Voltage vs Gate-Source Voltage

SMD PLASTIC-ENCAPSULATE MOSFETS SOT-23 SERIES

RATINGS AND CHARACTERISTIC CURVES (For Reference Only)

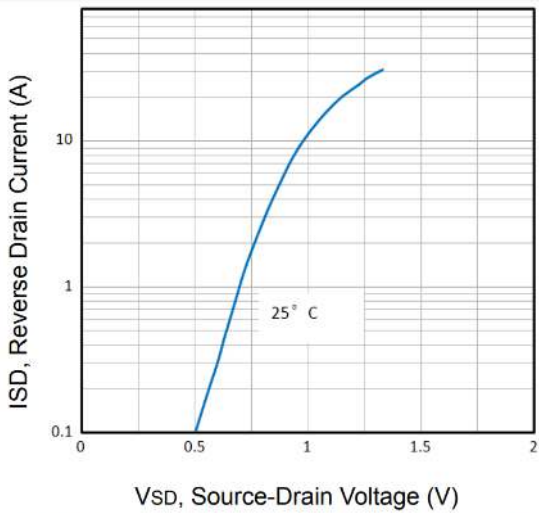

Fig5. Typical Source-Drain Diode Forward Voltage

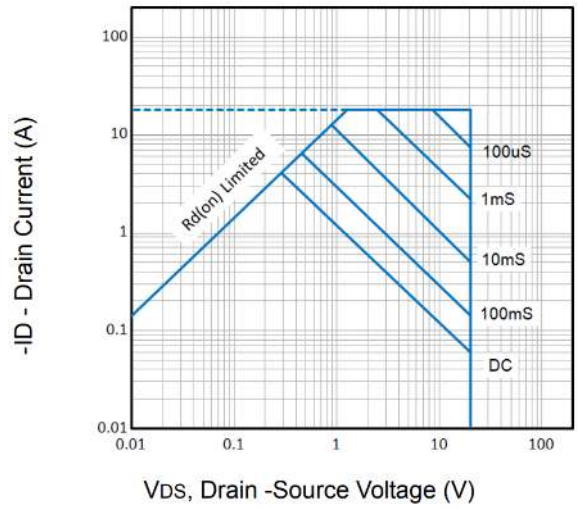

Fig6. Maximum Safe Operating Area

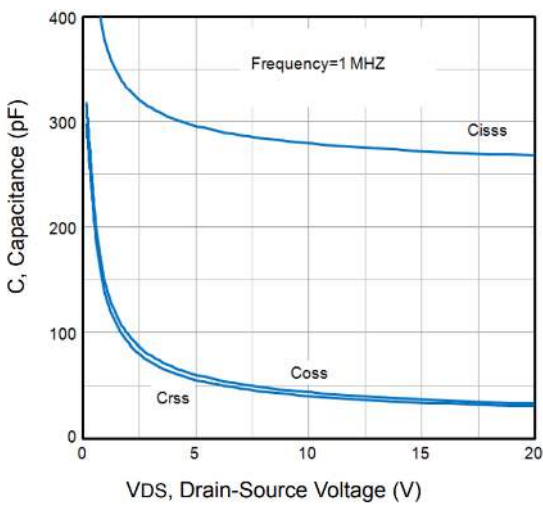

Fig7. Typical Capacitance Vs. Drain-Source Voltage

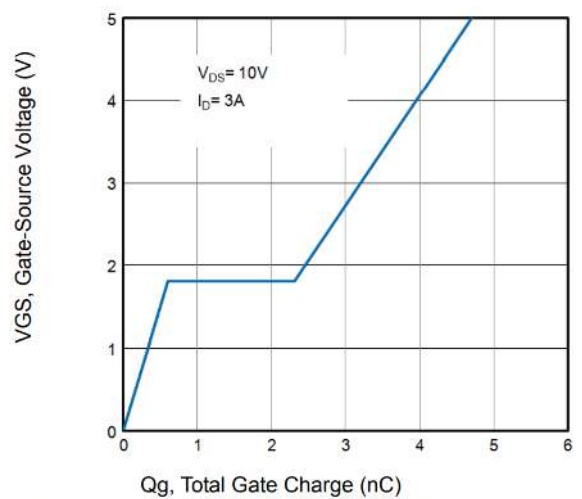

Fig8. Typical Gate Charge Vs. Gate-Source Voltage

SMD PLASTIC-ENCAPSULATE MOSFETS SOT-23 SERIES

RATINGS AND CHARACTERISTIC CURVES (For Reference Only)

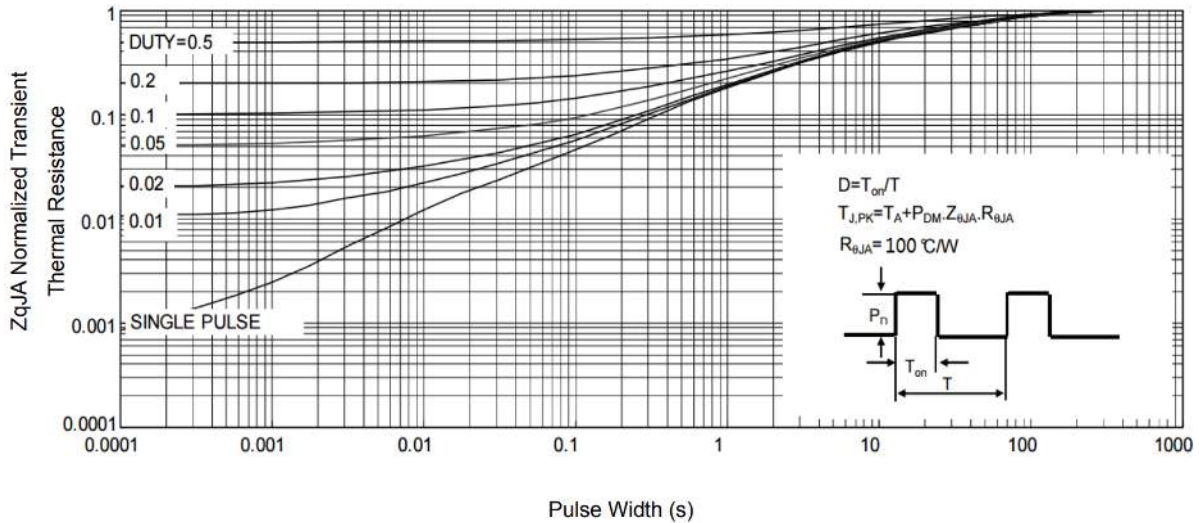

Fig9. Normalized Maximum Transient Thermal Impedance

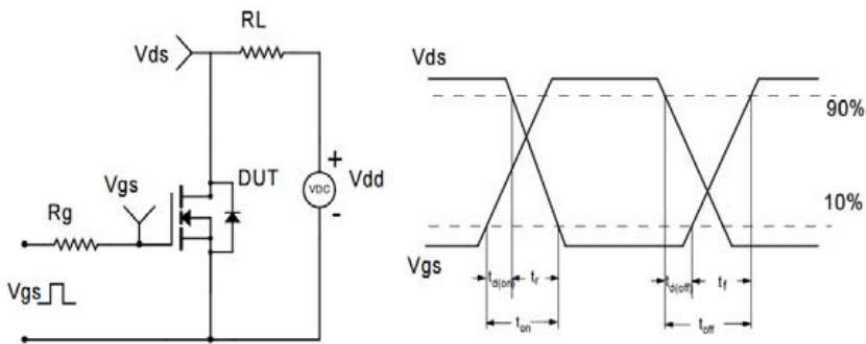
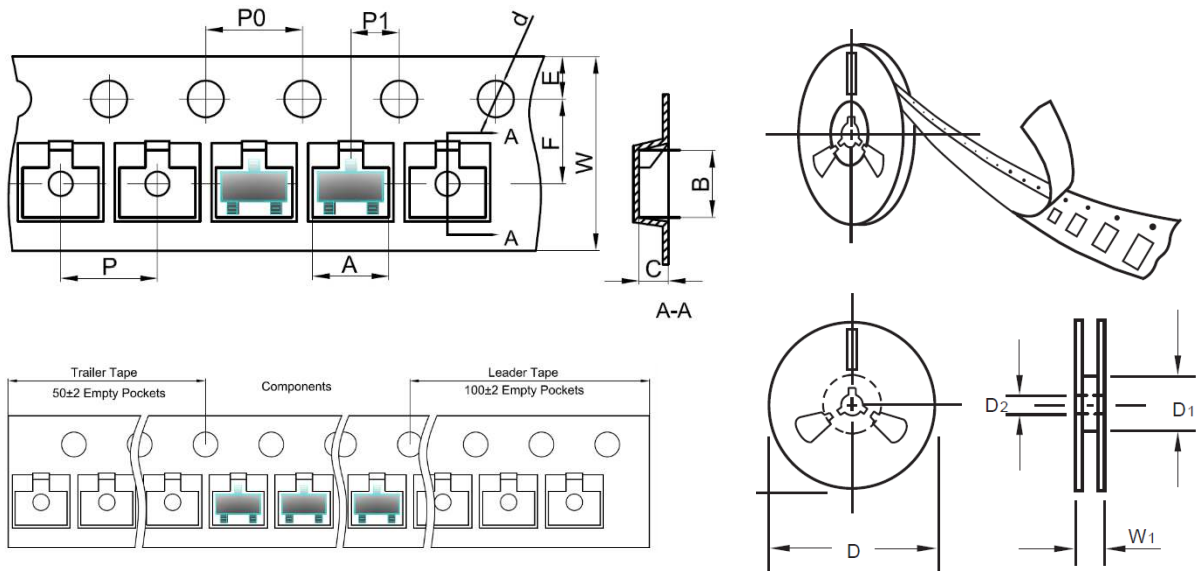

Fig10. Switching Time Test Circuit and waveforms

SMD PLASTIC-ENCAPSULATE MOSFETS SOT-23 SERIES

TAPE/REEL (Unit: mm)

All Devices are packed in accordance with EIA standard RS-481-A and specifications.



Item	Symbol	Tolerance	SOT-23
Carrier width	A	0.1	3.15
Carrier Length	B	0.1	2.77
Carrier Depth	C	0.1	1.22
Sprocket hole	d	0.05	1.55
7"Reel outside diameter	D	2.0	178.00
7"Reel inner diameter	D1	Min.	54.4
Feed hole diameter	D2	0.5	13.00
Sprocket hole position	E	0.1	1.75
Punch hole position	F	0.1	3.50
Punch hole pitch	P	0.1	4.00
Sprocket hole pitch	P0	0.1	4.00
Embossment center	P1	0.1	2.00
Overall tape thickness	T	0.1	0.25
Tape width	W	0.3	8.00
Reel width	W1	1.0	19.50

SMD PLASTIC-ENCAPSULATE MOSFETS SOT-23 SERIES

PACKAGE

Case Code	Reel Size	MPQ (pcs)	Component Spacing (mm)	Qty. Per Box (pcs)	Inner Box L*W*H (mm)	Reel Size (mm)	Carton size L*W*H (mm)	Qty. Per Carton (pcs)	G. W (kg)
SOT-23	7"	3,000		45,000	212*207*207	178	430*430*230	180,000	6.5

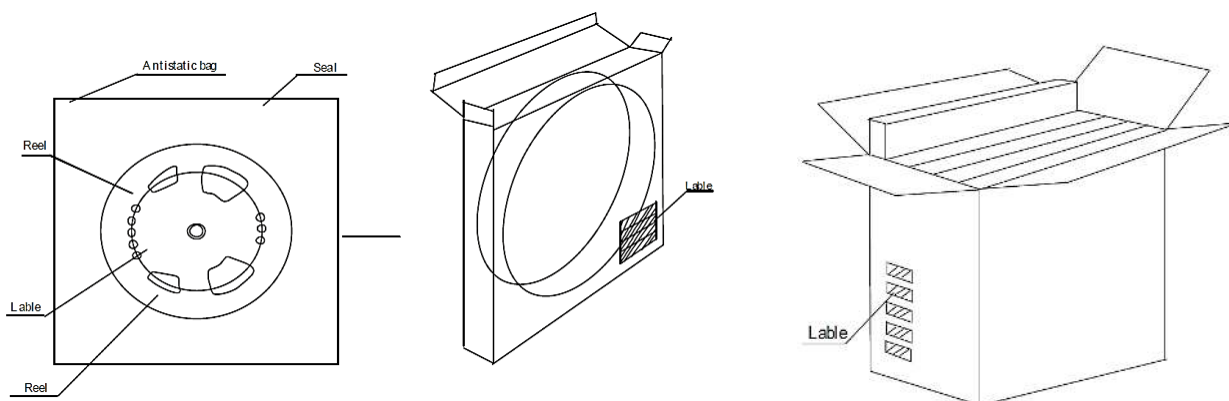

DISCLAIMER

NextGen Component, Inc. reserves the right to make changes to the product(s) and or information contained herein without notice. No liability is assumed as a result of their use or application. No rights under any patent accompany the sale of any such product(s) or information