



EVQ4425B-QB-00A

1.5A, 36V, 400kHz, High-Efficiency, Synchronous, Step-Down LED Driver Evaluation Board

DESCRIPTION

The EVQ4425B-QB-00A is an evaluation board for the MPQ4425B, a high-efficiency, synchronous, rectified, step-down, switch-mode LED driver with integrated internal power high-side and low-side MOSFETs (HS-FET and LS-FET, respectively).

The MPQ4425B offers a compact solution that achieves 1.5A of continuous output current, with excellent load and line regulation across a wide input supply range. Synchronous mode offers high efficiency during all operation.

The EVQ4425B-QB-00A is a fully assembled and tested evaluation board that generates load currents up to 1.5A across a 4V to 36V input voltage range.

ELECTRICAL SPECIFICATIONS

Parameter	Symbol	Value	Units
Input voltage	V _{EMI}	4 to 36	V
Output current	I _{OUT}	1.5	A

FEATURES

- Wide 4V to 36V Operating Input Range
- Internal 85mΩ HS-FET and 50mΩ LS-FET
- Synchronous Mode for High-Efficiency Operation
- 400kHz Default Switching Frequency
- PWM Dimming (100Hz Minimum Dimming Frequency)
- Forced Continuous Conduction Mode (FCCM)
- 0.2V Reference Voltage
- Internal Soft Start
- Fault Indication for LED Short/Open and Thermal Shutdown
- Over-Current Protection (OCP) with Valley Current Detection
- Thermal Shutdown
- Available in a QFN-13 (2.5mmx3mm) Package
- CISPR25 Class 5 Compliant
- Available in AEC-Q100 Grade 1

APPLICATIONS

- Automotive LED Lighting

All MPS parts are lead-free, halogen-free, and adhere to the RoHS directive. For MPS green status, please visit the MPS website under Quality Assurance. "MPS", the MPS logo, and "Simple, Easy Solutions" are trademarks of Monolithic Power Systems, Inc. or its subsidiaries.

EVQ4425B-QB-00A EVALUATION BOARD

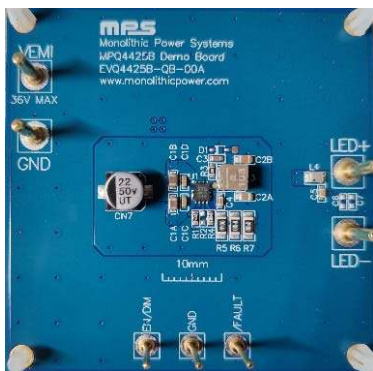

LxWxH (6.35cmx6.35cmx1.3cm)

Board Number	MPS IC Number
EVQ4425B-QB-00A	MPQ4425BGQ-AEC1

Efficiency vs. Input Voltage

V_{LED} = 6.4V

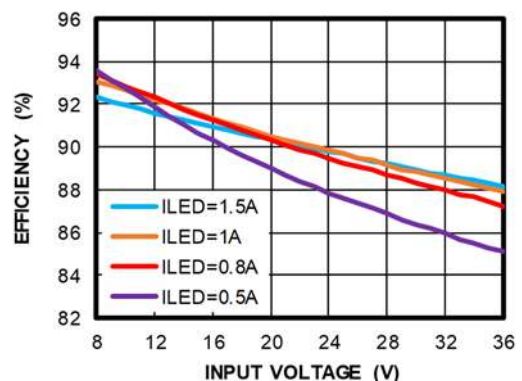

QUICK START GUIDE

1. Preset the power supply between 4V and 36V, then turn off the power supply.
2. If longer cables (>0.5m total) are being used between the source and the evaluation board, install a damping capacitor at the input terminals. This is critical when V_{IN} exceeds 24V.
3. Connect the power supply terminals to:
 - a. Positive (+): VEMI
 - b. Negative (-): GND
4. Connect the LED terminals to:
 - a. Positive (+): LED+
 - b. Negative (-): LED-
5. After making the connections, turn on the power supply. The MPQ4425B should automatically start up.
6. To use the enable (EN) function, apply a digital input to the EN pin. Drive EN above 1.45V to turn the regulator on; drive EN below 1V to turn it off.
7. To use the dimming function, apply a 100Hz to 2kHz external clock to the EN/DIM pin for pulse-width modulation (PWM) dimming.
8. The output current (I_{OUT}) is set by the external feedback resistor (R_{FB}). If the feedback reference voltage is 0.2V, I_{LED} can be calculated with Equation (1):

$$I_{LED} = \frac{0.2V}{R_{FB}} \quad (1)$$

Figure 1 shows the feedback resistor network.

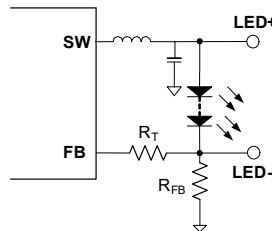

Figure 1: Feedback Resistor Network

9. A resistor (R_T) sets the loop bandwidth. A lower R_T results in higher bandwidth. However, a high bandwidth may cause insufficient phase margin, which causes an unstable loop. Choose an R_T value that achieves an appropriate tradeoff between bandwidth and phase margin.

Table 1 shows the recommended minimum R_{FB} and R_T values for common outputs using 1-series or 2-series LEDs.

Table 1: Recommended Resistor Values

I_{LED} (A)	R_{FB} (m Ω)	R_T (k Ω)
0.5	400 (1%)	200 (1%)
1	200 (1%)	150 (1%)
1.5	133 (1%)	100 (1%)

EVALUATION BOARD SCHEMATIC

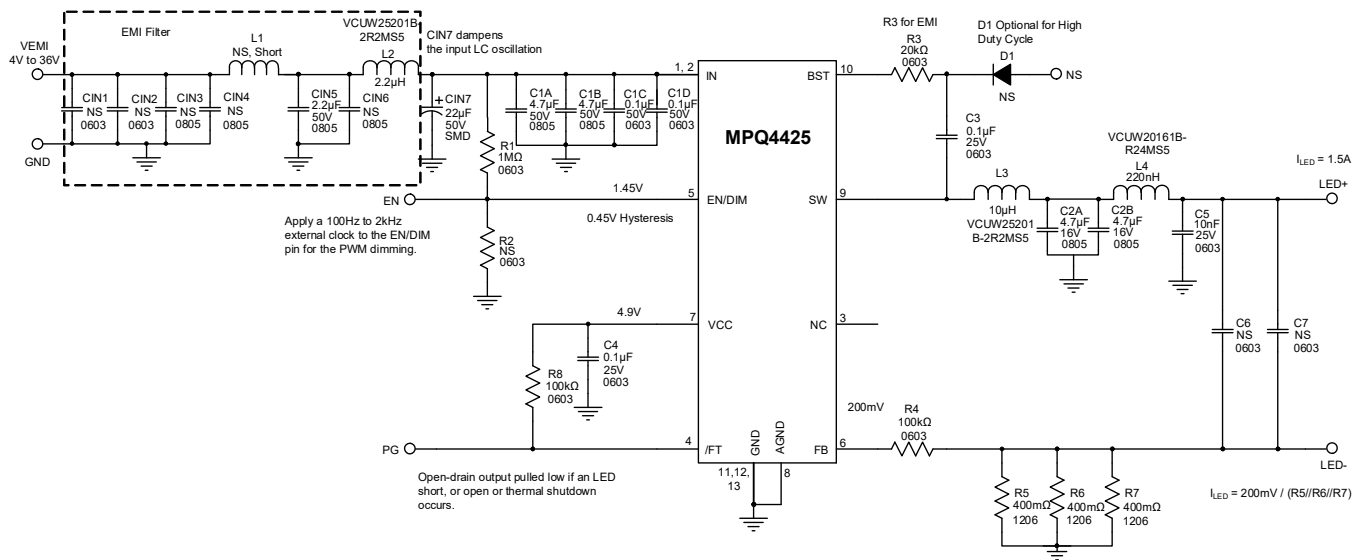

Figure 2: Evaluation Board Schematic

PACKAGE REFERENCE

TOP VIEW			
PGND	PGND	PGND	BST
13	12	11	10
			9 SW
IN	1		8 AGND
IN	2		7 VCC
			6
3	4	5	FB
NC	/FAULT	EN/DIM	
QFN-13 (2.5mmx3mm)			

EVQ4425B-QB-00A BILL OF MATERIALS

Qty	Ref	Value	Description	Package	Manufacturer	Manufacturer P/N
1	CIN5	2.2 μ F	Ceramic capacitor, 50V, X7R	0805	TDK	C2012X7R1H225K
1	CIN7	22 μ F	Electrolytic capacitor, 50V	SMD	Cotronic	UT1H220M0605VG
2	C1A, C1B	4.7 μ F	Ceramic capacitor, 50V, X7S	0805	Murata	GRM21BC71H475KE11L
2	C1C, C1D	0.1 μ F	Ceramic capacitor, 50V, X7R	0603	Murata	GRM188R71H104KA93D
2	C2A, C2B	4.7 μ F	Ceramic capacitor, 16V, X7R	0805	Murata	GCM21BR71C475KA73L
2	C3, C4	0.1 μ F	Ceramic capacitor, 25V, X7R	0603	Murata	GCJ188R71E104KA12D
1	C5	10nF	Ceramic capacitor, 25V, X7R	0603	Wurth	885012206065
7	CIN1, CIN2, CIN3, CIN4, CIN6, C6, C7	NS				
1	D1	NS				
1	L1	Short				
1	L2	2.2 μ H	Inductor, 70m Ω , DCR, 2.6A	SMD	Cyntec	VCUW25201B-2R2MS5
1	L3	10 μ H	Inductor, 84m Ω , DCR, 3.1A	SMD	Coilcraft	XAL4040-103MEB
1	L4	240nH	Inductor, 27m Ω , DCR, 6.5A	SMD	Cyntec	VCUW20161B-R24MS5
1	R1	1M Ω	Film resistor, 5%	0603	Yageo	RC0603JR-071ML
1	R3	20k Ω	Film resistor, 1%	0603	Yageo	RC0603FR-0720RL
2	R4, R8	100k Ω	Film resistor, 1%	0603	Yageo	RC0603FR-07100KL
3	R5, R6, R7	400m Ω	Film resistor, 1%	1206	Yageo	RL1206FR-070R4L
1	R2	NS				
1	U1	MPQ4425	Step-down regulator	QFN-13 (2mmx3mm)	MPS	MPQ4425BGQB-AEC1
4	VEMI, GND, LED+, LED-		2 golden pins		Custom	
3	EN/DIM, GND, /FAULT		1 golden pin		Custom	

EVB TEST RESULTS

Performance waveforms are tested on the evaluation board, $V_{IN} = 12V$, 2 LEDs in series, $L = 10\mu H$, $f_{SW} = 400kHz$, $T_A = 25^\circ C$, unless otherwise noted.

Efficiency vs. Input Voltage

1 LED ($V_{LED} = 3.2V$)

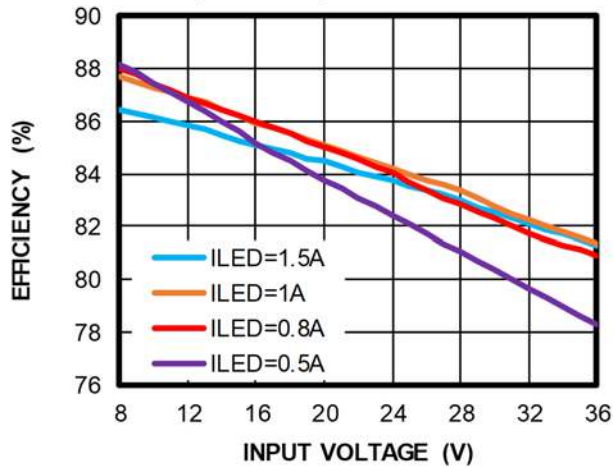

Efficiency vs. Input Voltage

2LEDs ($V_{LED} = 6.4V$)

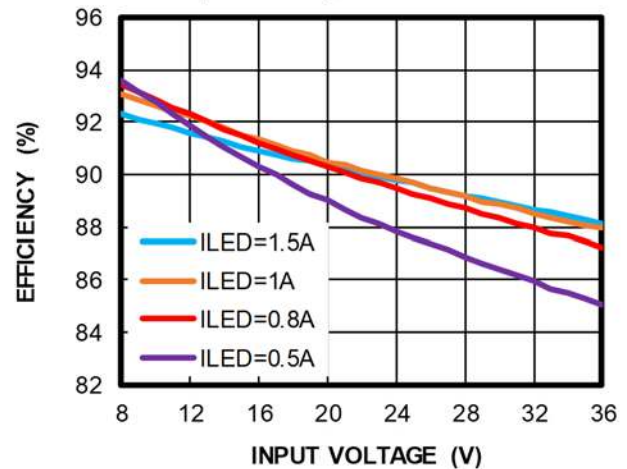

Current Limit vs. Duty

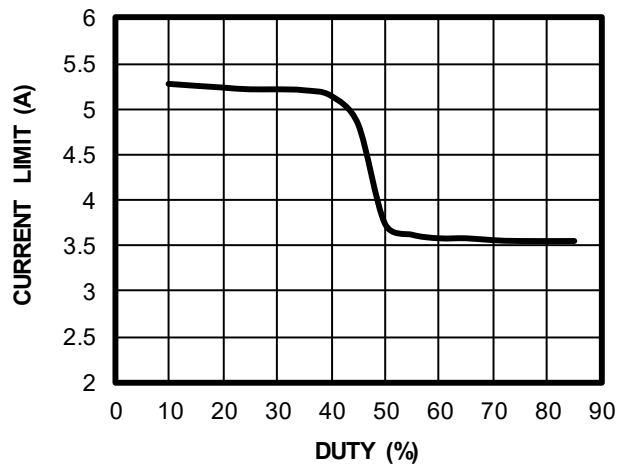

EVB TEST RESULTS (continued)

Performance waveforms are tested on the evaluation board, $V_{IN} = 12V$, 2 LEDs in series, $L = 10\mu H$, $f_{SW} = 400kHz$, $T_A = 25^\circ C$, unless otherwise noted.

CISPR25 Class 5 Peak Conducted Emissions

150kHz to 108MHz

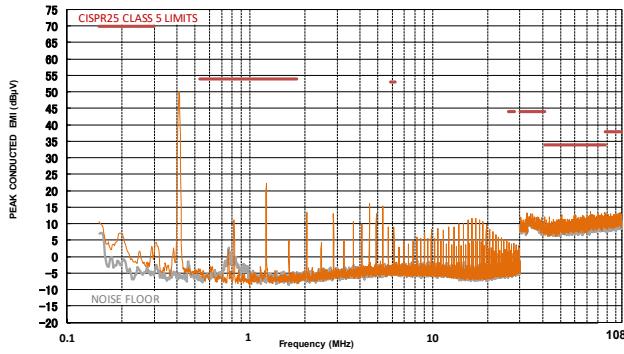

CISPR25 Class 5 Average Conducted Emissions

150kHz to 108MHz

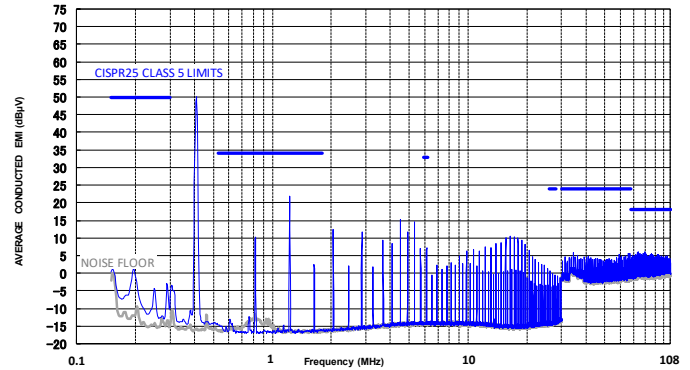

CISPR25 Class 5 Peak Radiated Emissions

150kHz to 30MHz

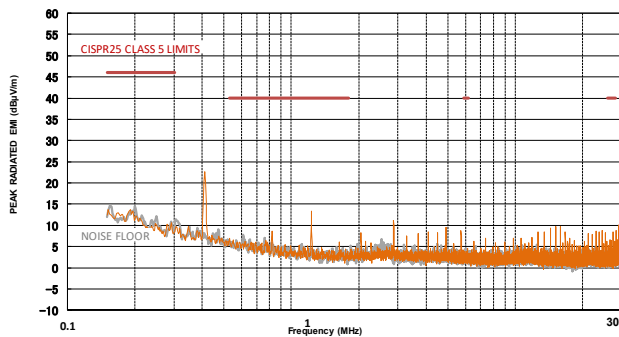

CISPR25 Class 5 Average Radiated Emissions

150kHz to 30MHz

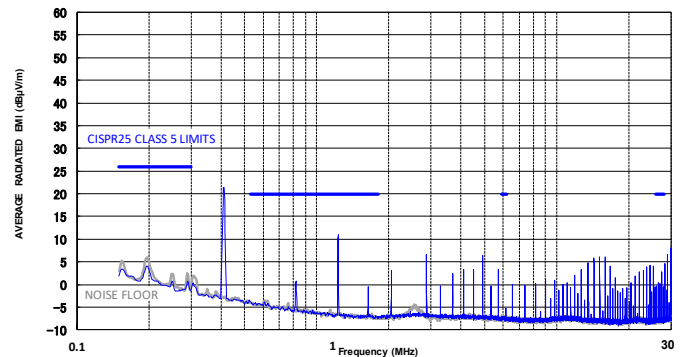

CISPR25 Class 5 Peak Radiated Emissions

Horizontal, 30MHz to 200MHz

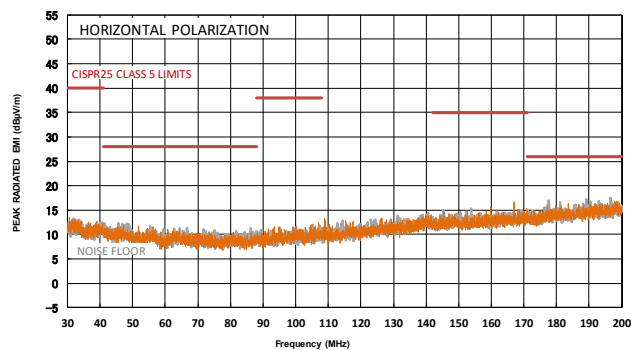

CISPR25 Class 5 Average Radiated Emissions

Horizontal, 30MHz to 200MHz

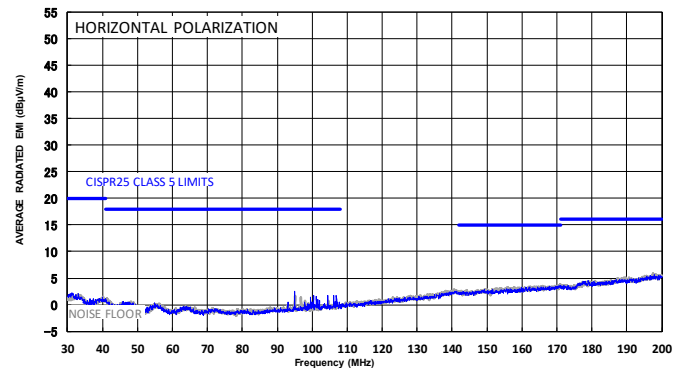

EVB TEST RESULTS (continued)

Performance waveforms are tested on the evaluation board, $V_{IN} = 12V$, 2 LEDs in series, $L = 10\mu H$, $f_{SW} = 400kHz$, $T_A = 25^\circ C$, unless otherwise noted.

CISPR25 Class 5 Peak Radiated Emissions

Vertical, 30MHz to 200MHz

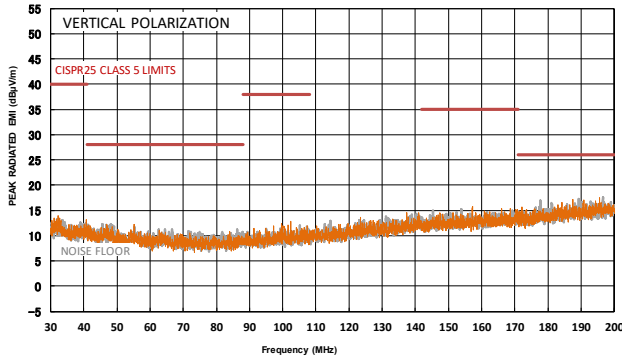

CISPR25 Class 5 Average Radiated Emissions

Vertical, 30MHz to 200MHz

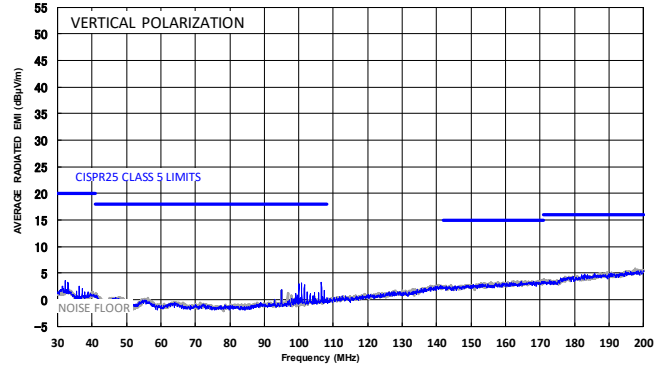

CISPR25 Class 5 Peak Radiated Emissions

Horizontal, 200MHz to 1GHz

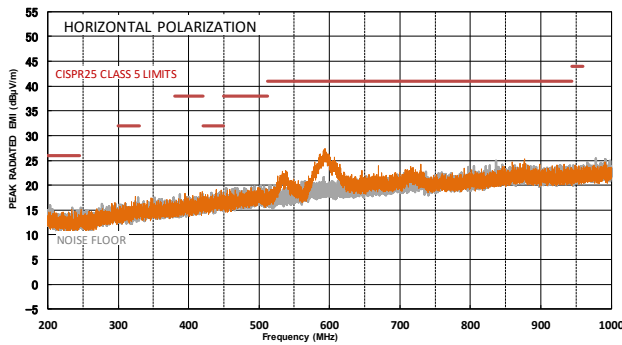

CISPR25 Class 5 Average Radiated Emissions

Horizontal, 200MHz to 1GHz

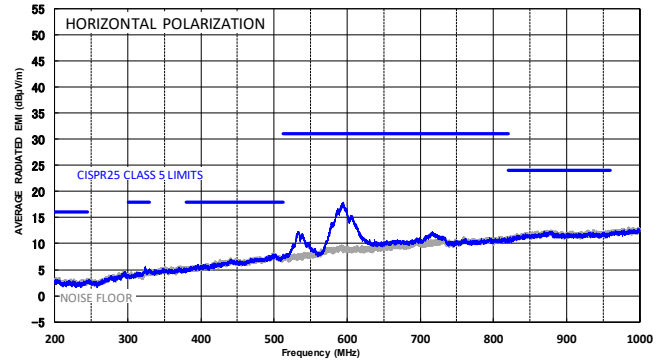

CISPR25 Class 5 Peak Radiated Emissions

Vertical, 200MHz to 1GHz

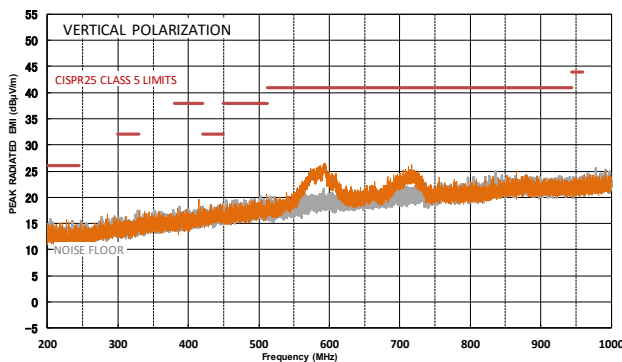

CISPR25 Class 5 Average Radiated Emissions

Vertical, 200MHz to 1GHz

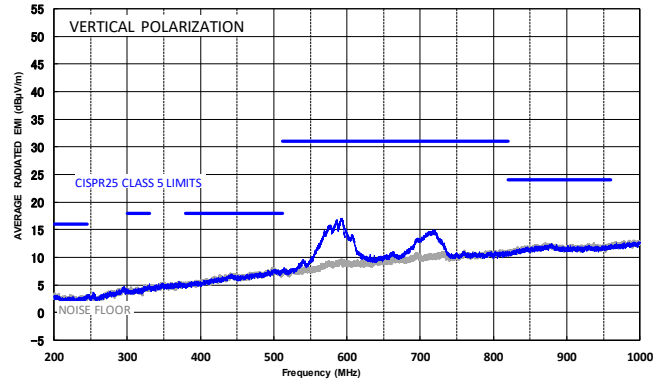

EVB TEST RESULTS (continued)

Performance waveforms are tested on the evaluation board, $V_{IN} = 12V$, 2 LEDs in series, $L = 10\mu H$, $f_{SW} = 400kHz$, $T_A = 25^\circ C$, unless otherwise noted.

Steady State

$I_{LED} = 1.5A$

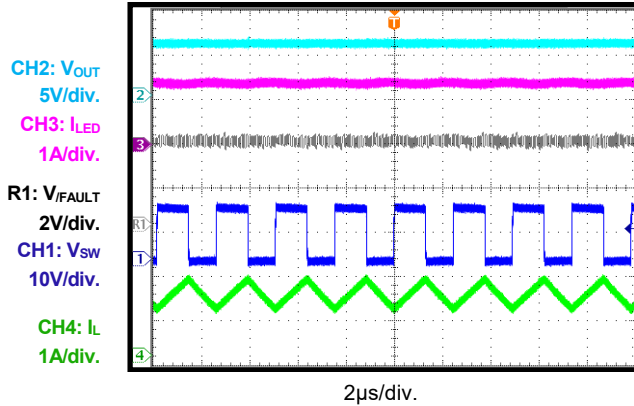

Start-Up through VIN

$I_{LED} = 1.5A$

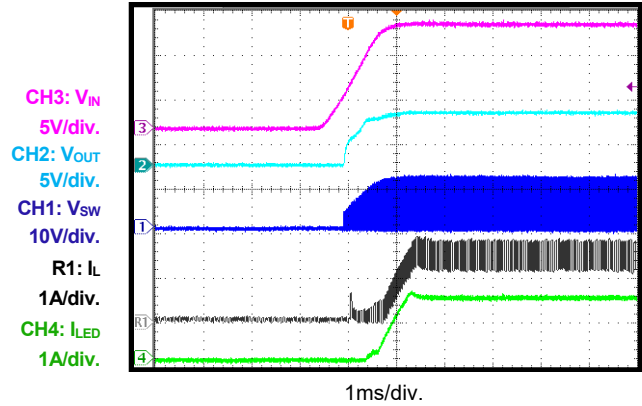

Shutdown through VIN

$I_{LED} = 1.5A$

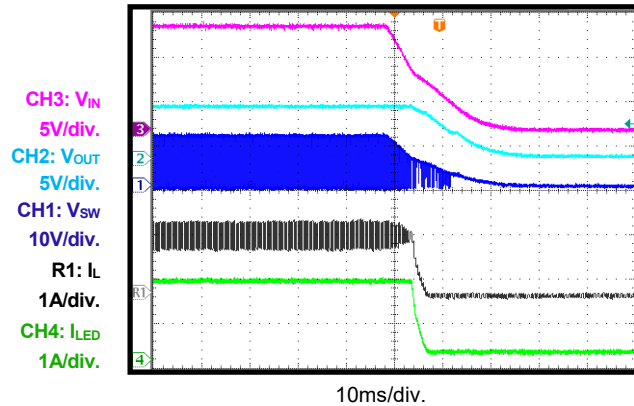

Start-Up through EN

$I_{LED} = 1.5A$

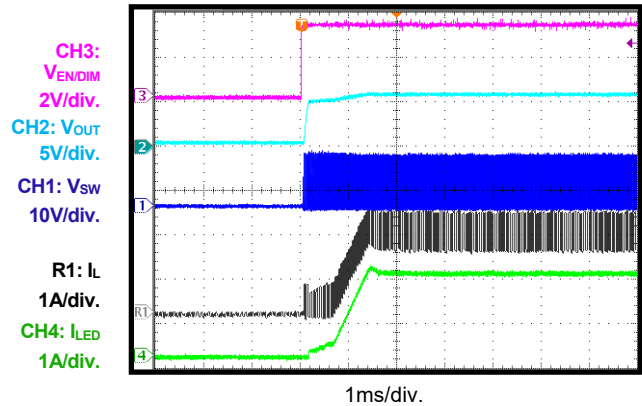

Shutdown through EN

$I_{LED} = 1.5A$

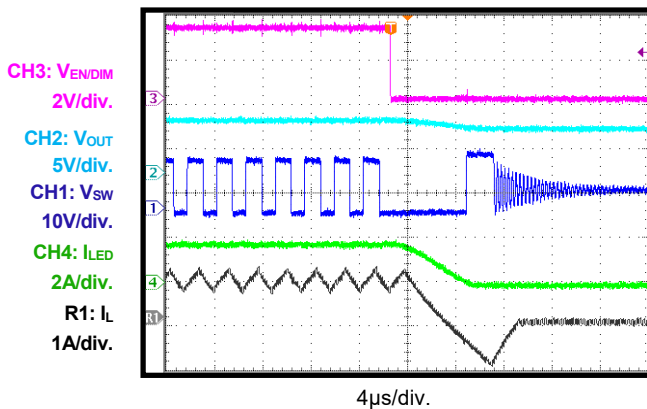

PWM Dimming

$f_{PWM} = 200Hz$, Duty = 50%

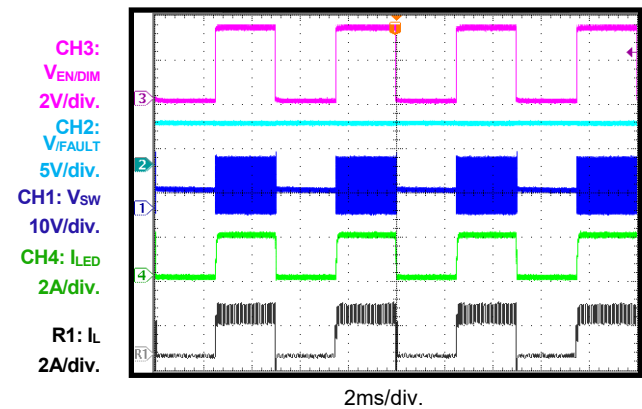

EVB TEST RESULTS (continued)

Performance waveforms are tested on the evaluation board, $V_{IN} = 12V$, 2 LEDs in series, $L = 10\mu H$, $f_{SW} = 400kHz$, $T_A = 25^\circ C$, unless otherwise noted.

PWM Dimming

$f_{PWM} = 2kHz$, Duty = 50%

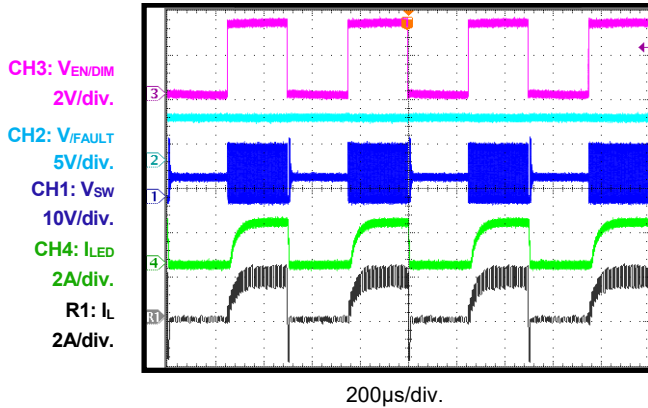

LED Open Steady State

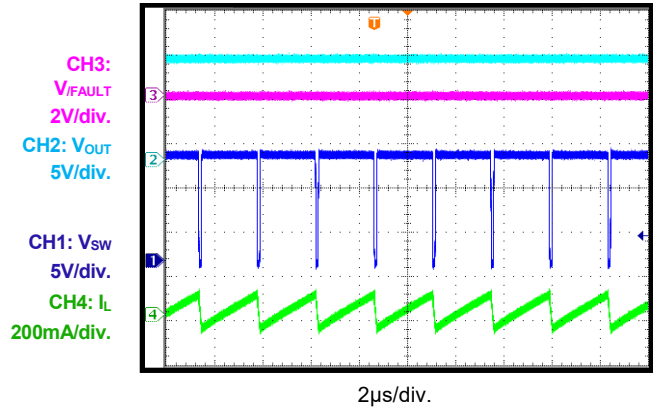

LED Open Input Start-Up

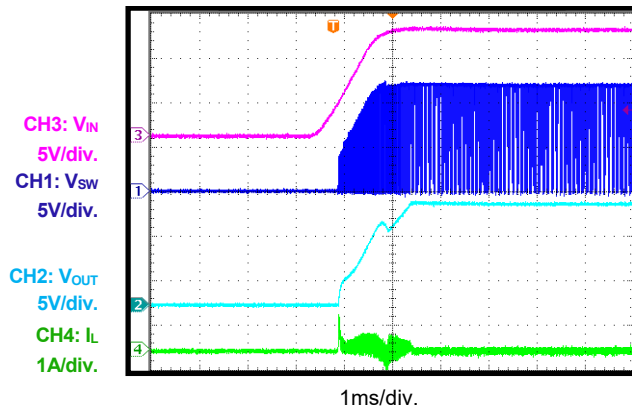

LED Open Input Shutdown

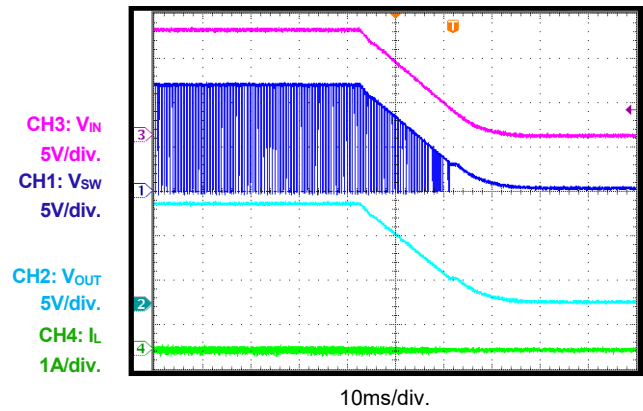

LED Open EN On

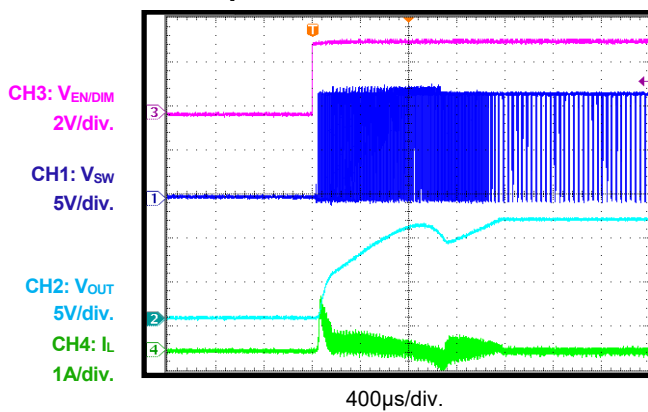

LED Open EN Off

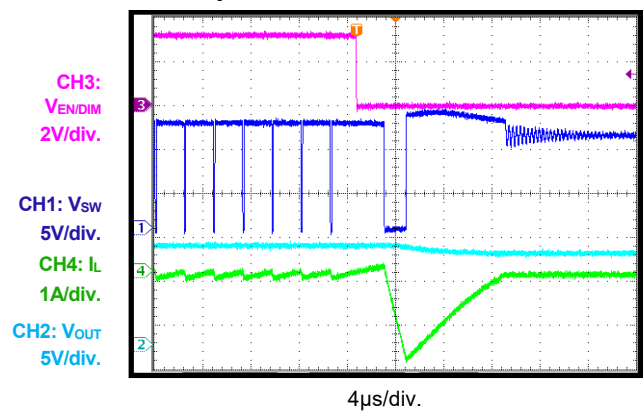

EVB TEST RESULTS (continued)

Performance waveforms are tested on the evaluation board, $V_{IN} = 12V$, 2 LEDs in series, $L = 10\mu H$, $f_{SW} = 400kHz$, $T_A = 25^\circ C$, unless otherwise noted.

LED Open Entry

$I_{LED} = 1.5A$

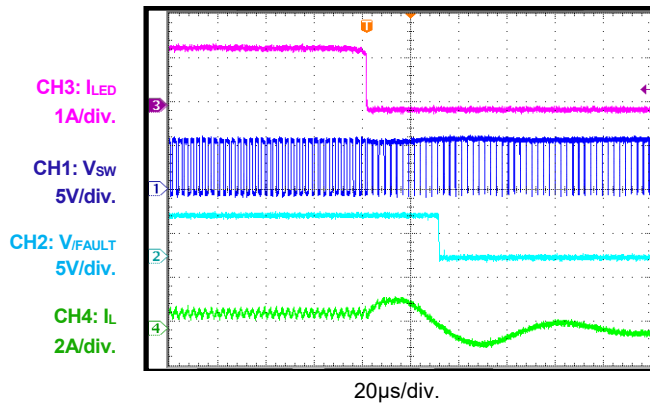

LED Open Recovery

$I_{LED} = 1.5A$

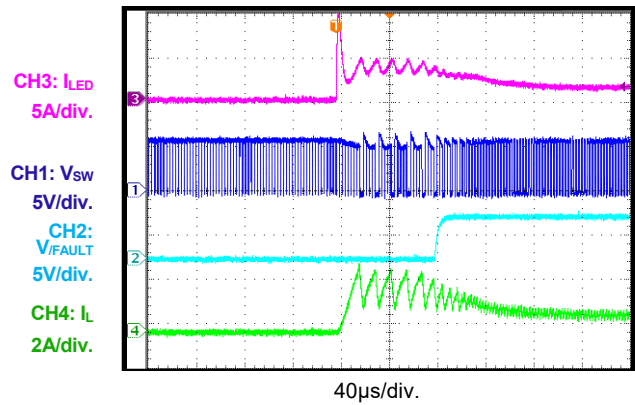

LED+ Short to GND Steady State

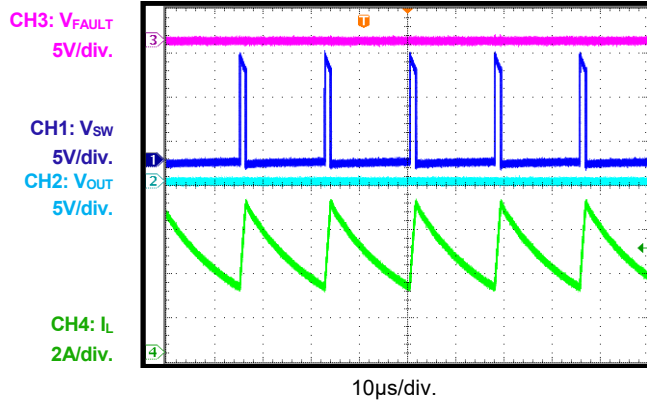

LED+ Short to GND Input Start-Up

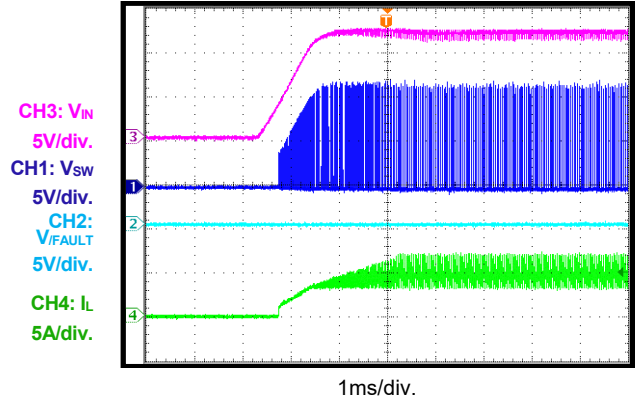

LED+ Short to GND Input Shutdown

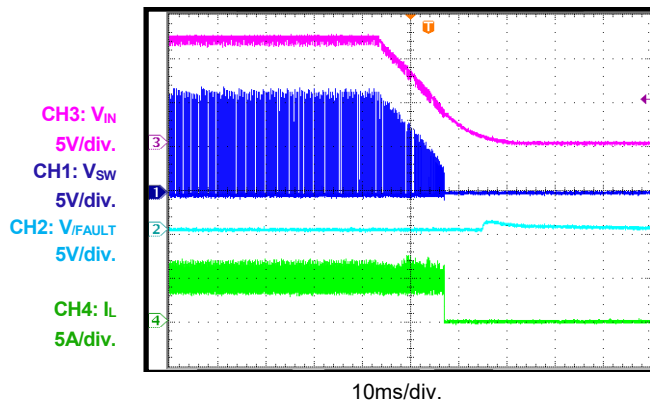

LED+ Short to GND EN On

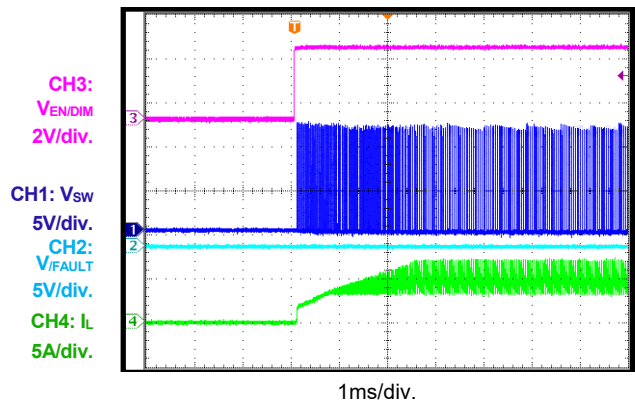

EVB TEST RESULTS (continued)

Performance waveforms are tested on the evaluation board, $V_{IN} = 12V$, 2 LEDs in series, $L = 10\mu H$, $f_{SW} = 400kHz$, $T_A = 25^\circ C$, unless otherwise noted.

LED+ Short to GND EN Off

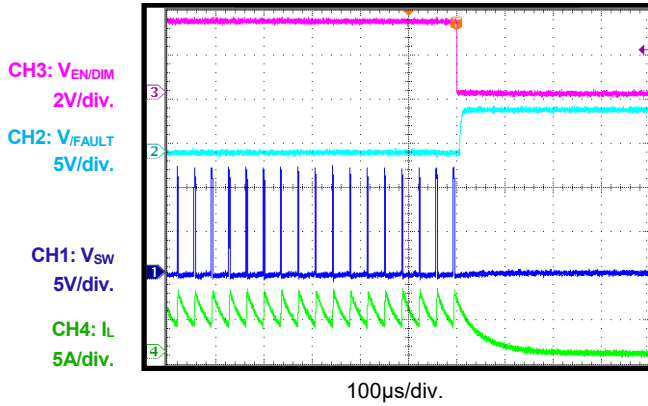

LED+ Short to GND Entry

$I_{LED} = 1.5A$

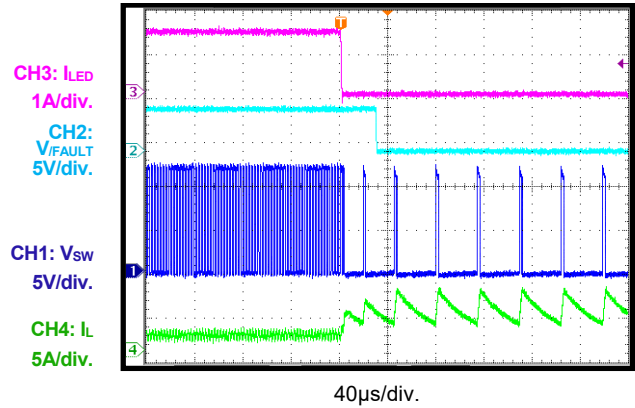

LED+ Short to GND Recovery

$I_{LED} = 1.5A$

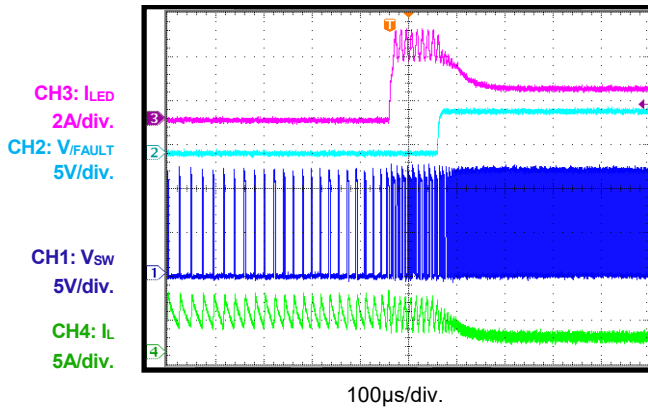

LED+ Short to LED- Entry

$I_{LED} = 1.5A$

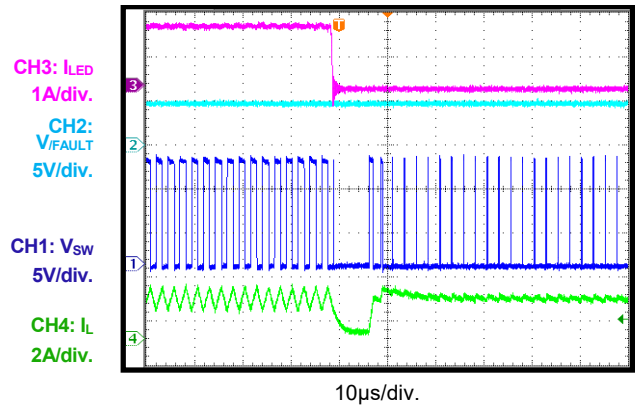

LED+ Short to LED- Recovery

$I_{LED} = 1.5A$

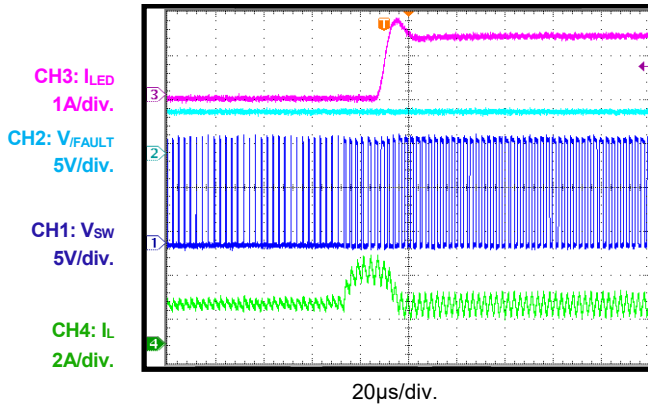

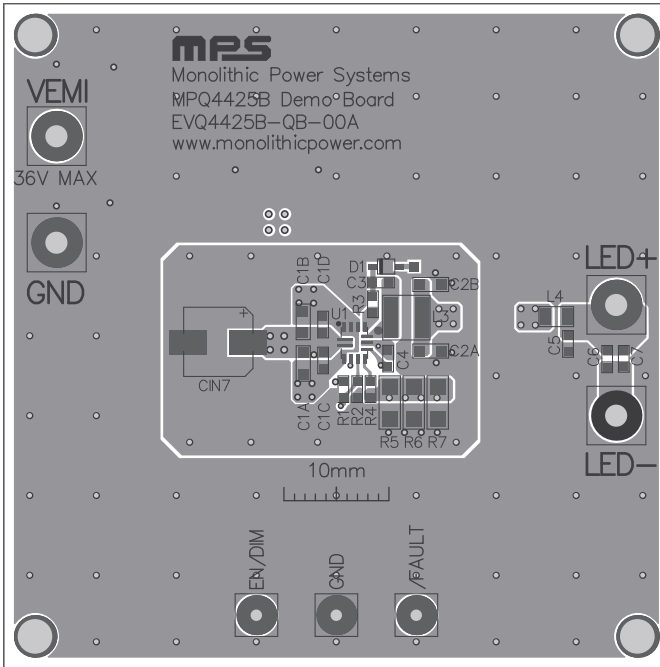
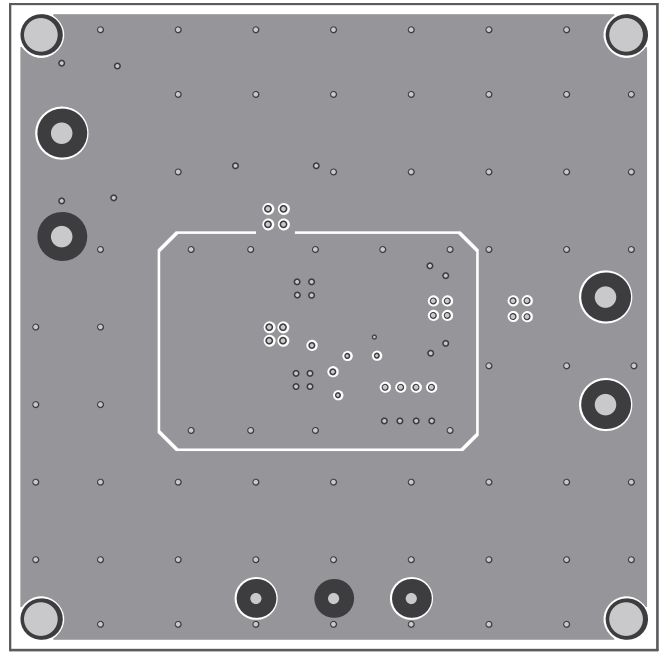
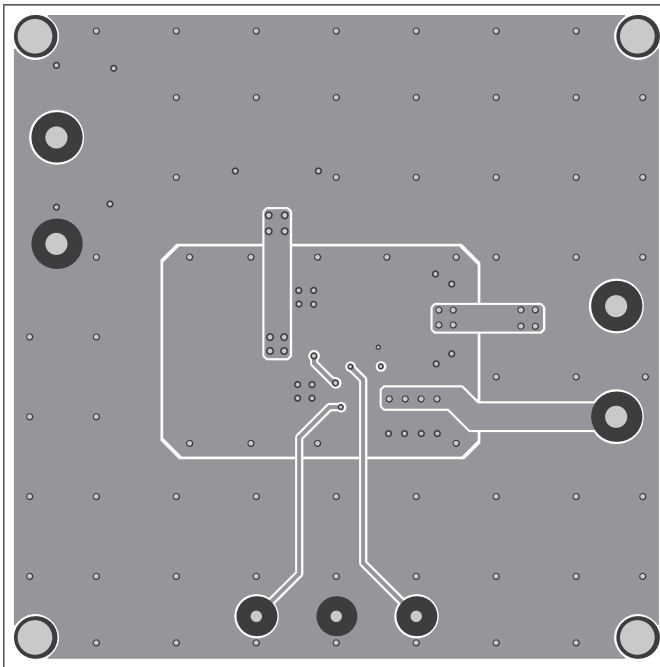
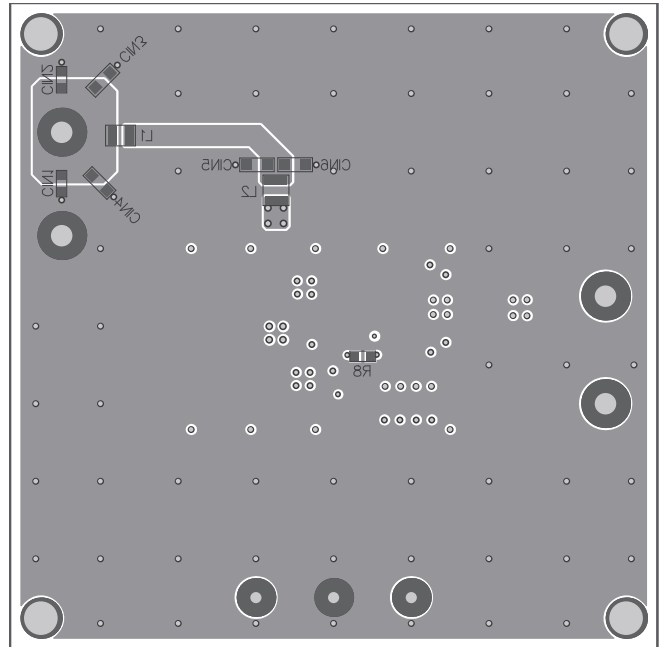
PCB LAYOUT**Figure 3: Top Silk and Top Layer****Figure 4: Mid-Layer 1****Figure 5: Mid-Layer 2****Figure 6: Bottom Layer and Bottom Silk**

REVISION HISTORY

Revision #	Revision Date	Description	Pages Updated
1.0	1/4/2021	Initial Release	-

Notice: The information in this document is subject to change without notice. Please contact MPS for current specifications. Users should warrant and guarantee that third-party Intellectual Property rights are not infringed upon when integrating MPS products into any application. MPS will not assume any legal responsibility for any said applications.