



IDT™ 89EBPES24T6G2 Evaluation Board Manual

(Eval Board: 18-656-000)

January 2008

6024 Silver Creek Valley Road, San Jose, California 95138
Telephone: (800) 345-7015 • (408) 284-8200 • FAX: (408) 284-2775
Printed in U.S.A.
©2008 Integrated Device Technology, Inc.

DISCLAIMER

Integrated Device Technology, Inc. reserves the right to make changes to its products or specifications at any time, without notice, in order to improve design or performance and to supply the best possible product. IDT does not assume any responsibility for use of any circuitry described other than the circuitry embodied in an IDT product. The Company makes no representations that circuitry described herein is free from patent infringement or other rights of third parties which may result from its use. No license is granted by implication or otherwise under any patent, patent rights or other rights, of Integrated Device Technology, Inc.

Boards that fail to function should be returned to IDT for replacement. Credit will not be given for the failed boards nor will a Failure Analysis be performed.

LIFE SUPPORT POLICY

Integrated Device Technology's products are not authorized for use as critical components in life support devices or systems unless a specific written agreement pertaining to such intended use is executed between the manufacturer and an officer of IDT.

1. Life support devices or systems are devices or systems which (a) are intended for surgical implant into the body or (b) support or sustain life and whose failure to perform, when properly used in accordance with instructions for use provided in the labeling, can be reasonably expected to result in a significant injury to the user.
2. A critical component is any components of a life support device or system whose failure to perform can be reasonably expected to cause the failure of the life support device or system, or to affect its safety or effectiveness.

IDT, the IDT logo, and Integrated Device Technology are trademarks or registered trademarks of Integrated Device Technology, Inc.



Table of Contents

Notes

Description of the EB24T6G2 Eval Board

Introduction	1-1
Board Features	1-2
Hardware	1-2
Software.....	1-2
Other.....	1-2
Revision History	1-2

Installation of the EB24T6G2 Eval Board

EB24T6G2 Installation	2-1
Hardware Description	2-1
Reference Clocks.....	2-1
Power Sources.....	2-2
External Power Source.....	2-2
PCI Express Analog High Power Voltage Converter	2-2
PCI Express Analog Power Voltage Converter	2-2
PCI Express Transmitter Analog Power Voltage Converter	2-2
Core Logic Voltage Converter	2-2
3.3V I/O Voltage Regulator.....	2-2
Power-up Sequence	2-3
Reset.....	2-3
Fundamental Reset	2-3
Downstream Reset	2-3
Boot Configuration Vector.....	2-3
SMBus Interfaces.....	2-4
SMBus Slave Interface	2-4
SMBus Master Interface	2-5
JTAG Header	2-6
Attention Buttons.....	2-6
Miscellaneous Jumpers, Headers.....	2-7
LEDs	2-8
PCI Express Connectors.....	2-9
EB24T6G2 Board Figure	2-11

Software for the EB24T6G2 Eval Board

Introduction	3-1
Device Management Software.....	3-1

Schematics

Schematics	4-1
------------------	-----

Notes



List of Tables

Notes

Table 2.1	Clock Source Selection	2-1
Table 2.2	SMA Connectors - Onboard Reference Clock	2-2
Table 2.3	External Power Connector - J1	2-2
Table 2.4	Downstream Reset Selection	2-3
Table 2.5	Boot Configuration Vector Signals	2-4
Table 2.6	Boot Configuration Vector Switches S7 & S8 (ON=0, OFF=1)	2-4
Table 2.7	Slave SMBus Interface Connector	2-5
Table 2.8	EEPROM SMBus Address Setting	2-5
Table 2.9	JTAG Connector Pin Out	2-6
Table 2.10	Attention Buttons	2-6
Table 2.11	Miscellaneous Jumpers, Headers	2-7
Table 2.12	LED Indicators	2-8
Table 2.13	PCI Express x8 Connector Pinout	2-9

Notes



List of Figures

Notes

Figure 1.1 Function Block Diagram of the EB24T6G2 Eval Board 1-1

Notes



Description of the EB24T6G2 Eval Board

Notes

Introduction

The 89HPES24T6G2 switch (also referred to as PES24T6G2 in this manual) is a member of IDT's PCI Express® standard based line of products. It is a PCIe® Base Specification 2.0 compliant (Gen2) 6-port switch, with 4 serial lanes per port. Two x4 ports can be merged to form one x8 port in PES24T6G2. One upstream port is provided for connecting to the root complex (RC), and up to five downstream ports are available for connecting to PCIe endpoints or to another switch. More information on this device can be found in the 89HPES24T6G2 User Manual.

The 89EBPES24T6G2 Evaluation Board (also referred to as EB24T6G2 in this manual) provides an evaluation platform for the PES24T6G2 switch. It is also a cost effective way to add PCIe ports (slots) to an existing system with limited number of PCIe ports/slots. The EB24T6G2 board is designed to function as an add-on card to be plugged into a x8 PCIe slot available on a motherboard hosting an appropriate root complex and microprocessor(s). The EB24T6G2 is a vehicle to test and evaluate the functionality of the PES24T6G2 switch. Customers can use this board to get a headstart on software development prior to the arrival of their own hardware. The EB24T6G2 is also used by IDT to reproduce system-level hardware or software issues reported by customers. Figure 1.1 illustrates the functional block diagram representing the main parts of the EB24T6G2 board.

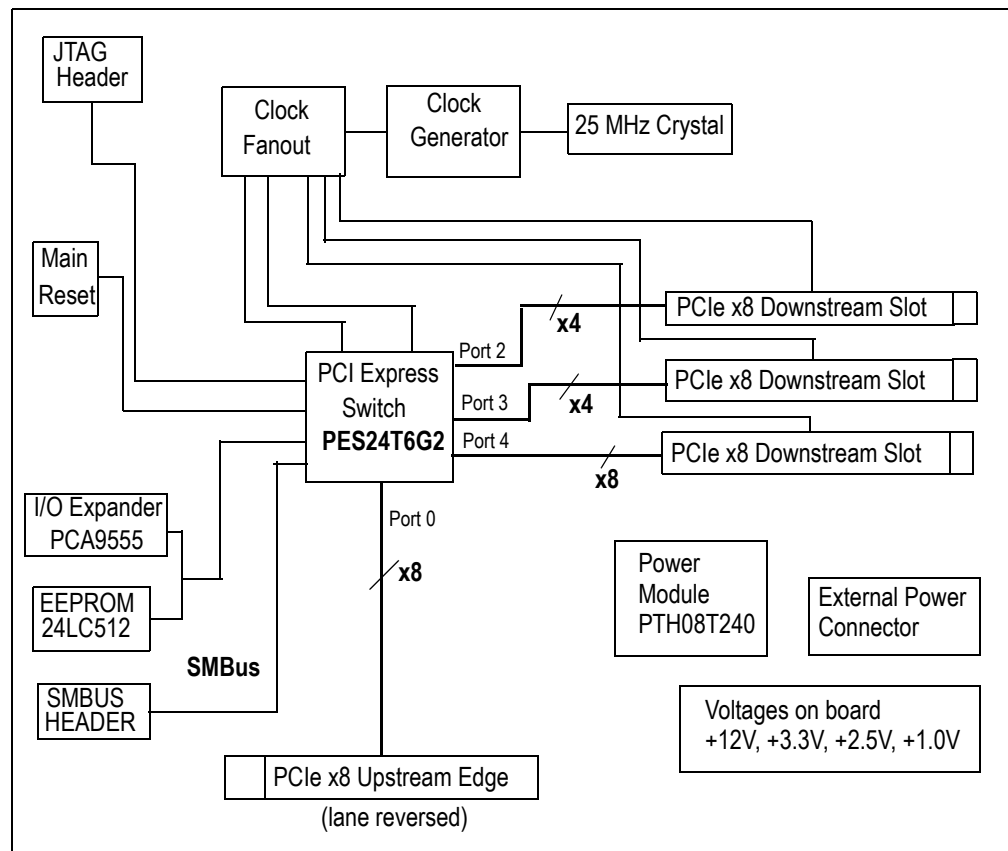

Figure 1.1 Function Block Diagram of the EB24T6G2 Eval Board

Notes

Board Features

Hardware

- ◆ **PES24T6G2 PCIe 6 port switch**
 - Up to six x4 ports, 24 PCIe lanes
 - PCIe Base Specification Revision 2.0 compliant (Gen2 SerDes speeds of 5 GT/S)
 - Up to 2048 byte maximum Payload Size
 - Automatic lane reversal and polarity inversion supported on all lanes
 - Automatic per port link width negotiation to x8, x4, x2, x1
 - Load configuration from an optional serial EEPROM via SMBUS
- ◆ **Upstream, Downstream Port**
 - One edge connector on the upstream port, to be plugged into a slot with at least x8 capable on a host motherboard
 - Three slot connectors on the downstream ports, for PCIe endpoint add-on cards to be plugged in. These slot connectors are x8 mechanically and electrically connected as one x8 and two x4, but open-ended for card widths greater than x8 (e.g. x16).
- ◆ **Numerous user selectable configurations set using onboard jumpers and DIP-switches**
 - Source of clock - host clock or onboard clock generator
 - Two clock rates (100/125 MHz) from an onboard clock generator
 - Boot mode selection
- ◆ **SMBUS Slave Interface (4 pin header)**
- ◆ **SMBUS Master Interface connected to the Serial EEPROMs through I/O expander**
- ◆ **“Attention” button for each downstream port to initiate a hot swap event on each port**
- ◆ **Four pin connector for optional external power supply**
- ◆ **Push button for Warm Reset**
- ◆ **Several LEDs to display status, reset, power, “Attention”, etc.**
- ◆ **One 10-pin JTAG connector (pitch 2.54 mm x 2.54 mm)**

Software

There is no software or firmware executed on the board. However, useful software is provided along with the Evaluation Board to facilitate configuration and evaluation of the PES24T6G2 within host systems running popular operating systems.

- ◆ **Installation programs**
 - *Operating Systems Supported: Windows2000, WindowsXP, Vista, Linux*
- ◆ **GUI based application for Windows and Linux**
 - *Allows users to view and modify registers in the PES24T6G2*
 - *Binary file generator for programming the serial EEPROMs attached to the SMBUS.*

Other

- ◆ A metal bracket is provided to firmly hold in place three endpoints plugged into the EB24T6G2 board.
- ◆ An external power supply may be required under some conditions.
- ◆ SMBUS cable may be required for certain evaluation exercises.
- ◆ SMA connectors are provided on the EB24T6G2 board for clock outputs.

Revision History

January 21, 2008: Initial publication of eval board manual.



Installation of the EB24T6G2 Eval Board

Notes

EB24T6G2 Installation

This chapter discusses the steps required to configure and install the EB24T6G2 evaluation board. All available DIP switches and jumper configurations are explained in detail.

The primary installation steps are:

1. Configure jumper/switch options suitable for the evaluation or application requirements.
2. Connect PCI Express endpoint cards to the downstream port PCIe slots on the evaluation board.
3. Make sure that the host system (motherboard with root complex chipset) is powered off.
4. Insert the evaluation board into the host system.
5. Apply power to the host system.

The EB24T6G2 board is typically shipped with all jumpers and switches configured to their default settings. In most cases, the board does not require further modification or setup.

Hardware Description

The PES24T6G2 is a 24-lane, 6-port PCI Express® switch. It is a peripheral chip that performs PCI Express based switching with a feature set optimized for high performance applications such as servers and storage. It provides fan-out and switching functions between a PCI Express upstream port and downstream ports or peer-to-peer switching between downstream ports.

The EB24T6G2 has three PCI Express downstream ports, accessible through three x8 connectors. One port is capable of negotiating a x1, x2, x4, and x8 link width and two other ports are capable of negotiating a x1, x2, or x4 link width. All endpoint cards connected to the PES24T6G2 must support one of these link widths.

Basic requirements for the board to run are:

- Host system with a PCI Express root complex supporting at least x8 configuration through a PCI Express x8 or larger slot.
- x1, x2, x4 or x8 PCI Express Endpoint Cards.

Reference Clocks

The PES24T6G2 requires a differential reference clock. The EB24T6G2 derives this clock from a common source which is user-selectable. The common source can be either the host system's reference clock or it can be the onboard clock generator. Selection is made by stuffing resistors as in Table 2.1.

Clock Configuration Stuffing Option	
W6 and W7	Clock Source
Pins 2 and 3	Onboard Reference Clock – Use onboard clock generator
Pins 1 and 2	Upstream Reference Clock – Host system provides clock (Default)

Table 2.1 Clock Source Selection

The source for the onboard clock is the ICS841484 clock generator device (U4) connected to a 25MHz oscillator (Y1). When using the onboard clock generator, the output frequency is fixed at 100MHz, therefore FSEL0 (S7, bit 8) is On as the default setting.

Notes

The output of the onboard clock generator is accessible through two SMA connectors located on the Evaluation Board. See Table 2.2. This can be used to connect a scope for probing or capturing purposes and cannot be used to drive the clock from an external source.

Onboard Reference Clock Output (Differential) – J7, J6	
J9	Positive Reference Clock
J10	Negative Reference Clock

Table 2.2 SMA Connectors - Onboard Reference Clock

Power Sources

The EB24T6G2 and all downstream ports are powered from the upstream port slot power. If add-in cards require more power than the upstream slot can support, an external source is required to supply this extra power via an auxiliary 4-pin power connector on the board. Header W1, W2, and W3 (see Table 2.11) are used to select proper power source for the switch and all downstream ports.

External Power Source

If necessary, external power is supplied to the EB24T6G2 board through a 4-pin auxiliary power connector attached to J4. The external power supply provides +12V to the EB24T6G2 as described in Table 2.3. The +5V is unused.

Pin	Signal
1	+12V
2	GND
3	GND
4	+5V

Table 2.3 External Power Connector - J1

PCI Express Analog High Power Voltage Converter

A DC-DC converter (U18) provides a 2.5V PCI Express analog high power voltage (shown as VDDHA) to the PES24T6G2.

PCI Express Analog Power Voltage Converter

A separate DC-DC converter (U16) provides a 1.0V PCI Express analog power voltage (VDDA) to the PES24T6G2.

PCI Express Transmitter Analog Power Voltage Converter

A separate DC-DC converter (U17) provides a 1.0V PCI Express transmitter analog power voltage (shown as VDDPETA) to the PES24T6G2.

Core Logic Voltage Converter

A separate DC-DC converter (U15) provides the 1.0V core voltage (VDDCORE) to the PES24T6G2.

3.3V I/O Voltage Regulator

A 12V to 3.3V voltage regulator (VR1) provides the 3.3V I/O voltage (VDDIO) to the PES24T6G2.

Notes

Power-up Sequence

During power supply ramp-up, VDDCORE must remain at least 1.0V below VDDIO at all times. There are no other power-up sequence requirements for the various operating supply voltages.

Reset

The PES24T6G2 supports two types of reset mechanisms as described in the PCI Express specification:

- Fundamental Reset: This is a system-generated reset that propagates along the PCI Express tree through a single side-band signal PERST# which is connected to the Root Complex, the PES24T6G2, and the endpoints.
- Hot Reset: This is an In-band Reset, communicated downstream via a link from one device to another. Hot Reset may be initiated by software. This is further discussed in the 89HPES24T6G2 User Manual. The EB24T6G2 evaluation board provides seamless support for Hot Reset.

Fundamental Reset

There are two types of Fundamental Resets which may occur on the EB24T6G2 evaluation board:

- Cold Reset: During initial power-on, the onboard voltage monitor (TLC7733D) will assert the PCI Express Reset (PERSTN) input pin of the PES24T6G2.
- Warm Reset: This is triggered by hardware while the device is powered on. Warm Reset can be initiated by two methods:
 - Pressing a push-button switch (S1) located on EB24T6G2 board
 - The host system board IO Controller Hub asserting PERST# signal, which propagates through the PCIe upstream edge connector of the EB24T6G2. Note that one can bypass the onboard voltage monitor (TLC7733D) by moving the shunt from pin 1-2 to pin 2-3 (default) on W4.

Both events cause the onboard voltage monitor (TLC7733D) to assert the PCI Express Reset (PERSTN) input of the PES24T6G2 while power is on.

Downstream Reset

The PES24T6G2 provides a choice of either a software-controlled reset for each downstream port through GPIO pins or a fundamental reset through PERST#. Selection is made by jumpers described in Table 2.4.

Port #	Jumper	Selection
2	W19	[1-2] Software controlled reset through GPIO0 [2-3] Fundamental reset PERST# (default)
3	W17	[1-2] Software controlled reset through GPIO9 [2-3] Fundamental reset PERST# (default)
4	W18	[1-2] Software controlled reset through GPIO1 [2-3] Fundamental reset PERST# (default)

Table 2.4 Downstream Reset Selection

Boot Configuration Vector

A boot configuration vector consisting of the signals listed in Table 2.5 is sampled by the PES24T6G2 during a fundamental reset (while PERSTN is active). The boot configuration vector defines the essential parameters for switch operation and is set using DIP switches S7 and S8 as defined in Table 2.6.

Notes

Signal	Description
CCLKDS	Common Clock Downstream. The assertion of this pin indicates that all downstream ports are using the same clock source as that provided to downstream devices. This pin is used as the initial value of the Slot Clock Configuration bit in all of the Link Status Registers for downstream ports. The value may be overridden by modifying the SCLK bit in the downstream port's PCIELSTS register. Default: 0x1
CCLKUS	Common Clock Upstream. The assertion of this pin indicates that the upstream port is using the same clock source as the upstream device. This pin is used as the initial value of the Slot Clock Configuration bit in the Link Status Register for the upstream port. The value may be overridden by modifying the SCLK bit in the P0_PCIELSTS register. Default: 0x1
SWMODE[2:0]	Switch Mode. These configuration pins determine the PES24T6G2 switch operating mode. Default: 0x0 0x0 - Normal switch mode 0x1 - Normal switch mode with Serial EEPROM-based initialization 0x2 through 0x7 - Reserved

Table 2.5 Boot Configuration Vector Signals

Signal	Description	Default
S8[1]	CCLKDS	OFF
S8[2]	CCLKUS	OFF
S7[1]	SWMODE[0]	ON
S7[2]	SWMODE[1]	ON
S7[3]	SWMODE[2]	ON

Table 2.6 Boot Configuration Vector Switches S7 & S8 (ON=0, OFF=1)

SMBus Interfaces

The System Management Bus (SMBus) is a two-wire interface through which various system component chips can communicate. It is based on the principles of operation of I²C. Implementation of the SMBus signals in the PCI Express connector is optional and may not be present on the host system. The SMBus interface consists of an SMBus clock pin and an SMBus data pin.

Note: MSMBADDR and SSMBADDR address pins are not available in the PES24T6G2. The MSMBADDR address is hardwired to 0x50, and the SSMBADDR address is hardwired to 0x77.

The PES24T6G2 contains two SMBus interfaces: a slave SMBus interface and a master SMBus interface. The slave SMBus interface allows a SMBus Master device full access to all software-visible registers. The Master SMBus interface provides connection to the external serial EEPROM used for initialization and the I/O expanders used for hot-plug signals.

SMBus Slave Interface

On the PES24T6G2 board, the slave SMBus interface is accessible through the PCI Express edge connector as well as a 4-pin header as described in Table 2.7.

Note: The SMBus signals to the PCI Express edge connector is disabled by default. To enable them, place 0-ohm resistors at locations R160 and R161.

Notes

Slave SMBus Interface Connector J8	
Pin	Signal
1	N/C
2	SCL
3	GND
4	SDA

Table 2.7 Slave SMBus Interface Connector

The slave SMBus interface responds to the following SMBus transactions initiated by an SMBus master. Initiation of any SMBus transaction other than those listed above produces undefined results. See the SMBus 2.0 specification for a detailed description of the following transactions:

- Byte and Word Write/Read
- Block Write/Read

SMBus Master Interface

Connected to the master SMBus interface are four 16-bit I/O Expanders (PCA9555) and a serial EEPROM (24LC512). Four I/O Expanders are used as the interface for the onboard hot-plug controllers (MIC2591B). The lower three bits of the bus address for the I/O Expander0/1/2/4 are fixed as 0x0, 0x1, 0x2 and 0x4, respectively.

The seven bits address for the selected EEPROM device is **0b1010_000** by default and the lower three bit is configurable using switch S8 as described in 2.8.

S8[3]	S8[4]	S8[5]	Bus Address
OFF	OFF	OFF	0b111
OFF	OFF	ON	0b110
OFF	ON	OFF	0101
OFF	ON	ON	0b100
ON	OFF	OFF	0b011
ON	OFF	ON	0b010
ON	ON	OFF	0b001
ON	ON	ON	0b000 (Default)

Table 2.8 EEPROM SMBus Address Setting

Notes

JTAG Header

The PES24T6G2 provides a JTAG connector J5 for access to the PES24T6G2 JTAG interface. The connector is a 2.54 x 2.54 mm pitch male 10-pin connector. Refer to Table 2.9 for the JTAG Connector J5 pin out.

JTAG Connector J5					
Pin	Signal	Direction	Pin	Signal	Direction
1	/TRST - Test reset	Input	2	GND	—
3	TDI - Test data	Input	4	GND	—
5	TDO - Test data	Output	6	GND	—
7	TMS - Test mode select	Input	8	GND	—
9	TCK - Test clock	Input	10	GND	—

Table 2.9 JTAG Connector Pin Out

Attention Buttons

The PES24T6G2 features three attention buttons, shown in 2.10. Each button corresponds to a particular port and is used to initiate hot-swapping events.

Button	Description
S5	Port 2 Attention Button
S4	Port 3 Attention Button
S3	Port 4 Attention Button

Table 2.10 Attention Buttons

Notes
Miscellaneous Jumpers, Headers

Miscellaneous Jumpers, Headers			
Ref. Designator	Type	Default	Description
W1-W3	Header	1-2 Shunted	1-2: 12.0V source from Upstream Port (Default) 2-3: 12.0V source from external power connector
W20	Header	Shunted	Disable EEPROM Write protect feature (Default)
S6[1]	Switch	ON	ON: Port2, Force hot-plug controller on OFF: Port2, Power Enable bit controls hot-plug controller
S6[2]	Switch	ON	ON: Port3, Force hot-plug controller on OFF: Port3, Power Enable bit controls hot-plug controller
S6[3]	Switch	ON	ON: Port4, Force hot-plug controller on OFF: Port4, Power Enable bit controls hot-plug controller
W15	Header	2-3 Shunted	2-3: Port 2, +12V source from Upstream port (Default) 1-2: Port 2, +12V source from hot-plug controller
W9	Header	2-3 Shunted	2-3: Port 4, +12V source from Upstream port (Default) 1-2: Port 4, +12V source from hot-plug controller
W12	Header	2-3 Shunted	2-3: Port 3, +12 source from Upstream port (Default) 1-2: Port 3, +12 source from hot-plug controller
W16	Header	2-3 Shunted	2-3: Port 2, +3.3V source from Upstream port (Default) 1-2: Port 2, +3.3V source from hot-plug controller
W10	Header	2-3 Shunted	2-3: Port 4, +3.3V source from Upstream port (Default) 1-2: Port 4, +3.3V source from hot-plug controller
W13	Header	2-3 Shunted	2-3: Port 3, +3.3V source from Upstream port (Default) 1-2: Port 3, +3.3V source from hot-plug controller
W14	Header	2-3 Shunted	2-3: Port 2, +3.3AUX source from upstream port (Default) 1-2: Port 2, +3.3V source from hot-plug controller
W8	Header	2-3 Shunted	2-3: Port 4, +3.3AUX source from upstream port (Default) 1-2: Port 4, +3.3V source from hot-plug controller
W11	Header	2-3 Shunted	2-3: Port 3, +3.3AUX source from upstream port (Default) 1-2: Port 3, +3.3V source from hot-plug controller

Table 2.11 Miscellaneous Jumpers, Headers

Notes

LEDs

There are several LED indicators on the EB24T6G2 which convey status feedback. A description of each is provided in Table 2.12.

Location	Color	Definition
DS21	Green	Port 2: Power-is-good Indicator
DS9	Green	Port 3: Power-is-good Indicator
DS15	Green	Port 4: Power-is-good Indicator
DS20	Green	Port 2: Power Indicator
DS8	Green	Port 3: Power Indicator
DS14	Green	Port 4: Power Indicator
DS19	Yellow	Port 2: Attention Indicator
DS7	Yellow	Port 3: Attention Indicator
DS13	Yellow	Port 4: Attention Indicator
DS18	Green	Port 2: Activity Indicator
DS6	Green	Port 3: Activity Indicator
DS12	Green	Port 4: Activity Indicator
DS17	Green	Port 2: Linkup Indicator
DS5	Green	Port 3: Linkup Indicator
DS11	Green	Port 4: Linkup Indicator
DS23	Green	Port 0: Linkup Indicator
DS24	Green	Port 0: Activity Indicator
DS3	Red	Port 2/3: Power Fault Indicator
DS4	Red	Port 4: Power Fault Indicator
DS25	Green	GPIO8
DS26	Green	GPIO10

Table 2.12 LED Indicators

Notes
PCI Express Connectors

Pin	Side A		Side B	
1	+12V	12V power	PRSNT1#	Hot-Plug presence detect
2	+12V	12V power	+12V	12V power
3	RSVD	Reserved	+12V	12V power
4	GND	Ground	GND	Ground
5	SMCLK	SMBus clock	JTAG2	TCK (Test Clock) JTAG if clk i/p
6	SMDAT	SMBus Data	JTAG	TDI (Test Data Input)
7	GND	Ground	JTAG	TDO (Test Data Output)
8	+3.3V	3.3V power	JTAG	TMS (Test Mode Select)
9	JTAG1	TRST# (Test/Reset) resets JTAG if	+3.3V	3.3V power
10	3.3Vaux	3.3V auxiliary power	+3.3V	3.3V power
11	WAKE#	Signal for Link reactivation	PERST#	Fundamental Reset
Mechanical Key				
12	RSVD	Reserved	GND	Ground
13	GND	Ground	REFCLK+	REFCLK Reference clock
14	PETp0	Transmitter differential	REFCLK-	(differential pair)
15	PETn0	pair, Lane 0	GND	Ground
16	GND	Ground	PERp0	Receiver differential
17	PRSNT2#	Hot-Plug presence detect	PERn0	pair, Lane 0
18	GND	Ground	GND	Ground
19	PETp1	Transmitter differential	RSVD	Reserved
20	PETn1	pair, Lane 1	GND	Ground
21	GND	Ground	PERp1	Receiver differential
22	GND	Ground	PERn1	pair, Lane 1
23	PETp2	Transmitter differential	GND	Ground
24	PETn2	pair, Lane 2	GND	Ground
25	GND	Ground	PERp2	Receiver differential
26	GND	Ground	PERn2	pair, Lane 2
27	PETp3	Transmitter differential	GND	Ground
28	PETn3	pair, Lane 3	GND	Ground
29	GND	Ground	PERp3	Receiver differential
30	RSVD	Reserved	PERn3	pair, Lane 3
31	PRSNT2#	Hot-Plug presence detect	GND	Ground
32	GND	Ground	RSVD	Reserved
33	PETp4	Transmitter differential	RSVD	Reserved

Table 2.13 PCI Express x8 Connector Pinout (Part 1 of 2)

Notes

Pin	Side A		Side B	
34	PETn4	pair, Lane 4	GND	Ground
35	GND	Ground	PERp4	Receiver differential
36	GND	Ground	PERn4	pair, Lane 4
37	PETp5	Transmitter differential	GND	Ground
38	PETn5	pair, Lane 5	GND	Ground
39	GND	Ground	PERp5	Receiver differential
40	GND	Ground	PERn5	pair, Lane 5
41	PETp6	Transmitter differential	GND	Ground
42	PETn6	pair, Lane 6	GND	Ground
43	GND	Ground	PERp6	Receiver differential
44	GND	Ground	PERn6	pair, Lane 6
45	PETp7	Transmitter differential	GND	Ground
46	PETn7	pair, Lane 7	GND	Ground
47	GND	Ground	PERp7	Receiver differential
48	PRSNT2#	Hot-Plug presence detect	PERn7	pair, Lane 7
49	GND	Ground	GND	Ground

Table 2.13 PCI Express x8 Connector Pinout (Part 2 of 2)

Note: These x8 PCI Express connectors comply with the PCIe specification. However, the downstream ports on the EB24T6G2 are electrically connected in x4 and x8 configuration. According to the PCI Express specification, the PRSNT1# pin should be wired to the farthest available PRSNT2# pin on the connector. In the EB24T6G2, all PRSNT2# pins are tied together. This allows a board with a x1 or x4 width to be installed.

EB24T6G2 Board Figure

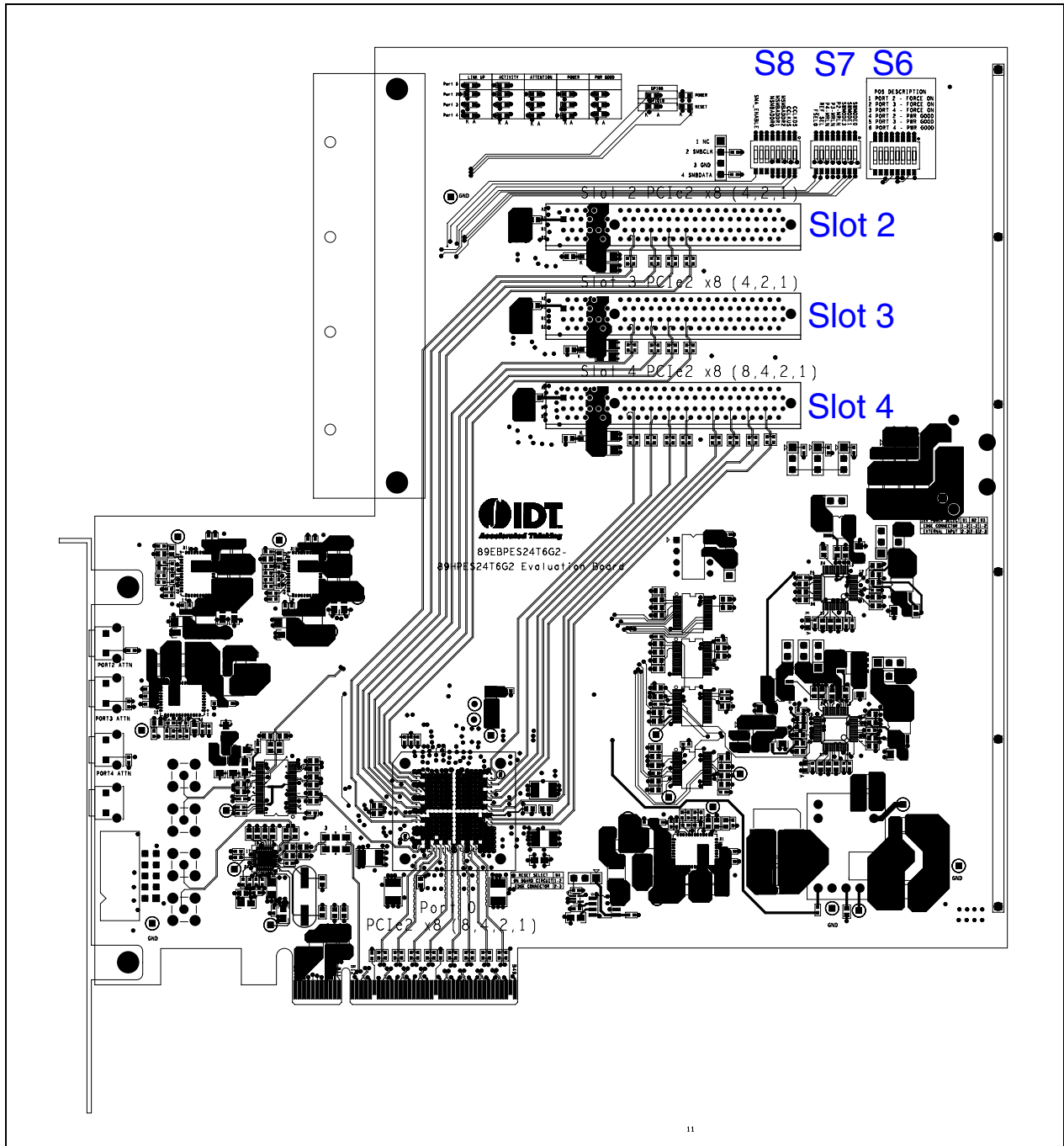



Software for the EB24T6G2 Eval Board

Notes

Introduction

This chapter discusses some of the main features of the available software to give users a better understanding of what can be achieved with the EB24T6G2 evaluation board using the device management software.

Device management software and related user documentation are available on a CD which is included in the Evaluation Board Kit. This information is also available on IDT's FTP site. For more information, contact IDT at ssdhelp@idt.com.

Device Management Software

The primary use of the Device Management Software package is to enable users of the evaluation board to access all the registers in the PES24T6G2 device. This access can be achieved using the PCI Express in-band configuration cycles through the upstream port on the PES24T6G2.

This software also enables users to save a snapshot of the current register set into a dump file which can be used for debugging purposes. An export/import facility is also available to create and use "Configuration" files which can be used to initialize the switch device with specific values in specific registers.

A conversion utility is also provided to translate a configuration file into an EEPROM programmable data structure. This enables the user to program an appropriate serial EEPROM with desirable register settings for the PES24T6G2, and then to populate that EEPROM onto the Evaluation Board. It is also possible to program the EEPROM directly on the Evaluation Board using a feature provided by the software package.

The front end of the Device Management Software is a user-friendly Graphical User Interface which allows the user to quickly read or write the registers of interest. The GUI also permits the user to run the software in "simulation" mode with no real hardware attached, allowing the creation of configuration files for the PES24T6G2 in the absence of the actual device.

Much of the Device Management Software is written with device-independent and OS-independent code. The software will be guaranteed to work on Linux (/sys interface) and MS Windows XP. It may function flawlessly on various flavors of MS Windows, but may not be validated on all. The fact that the software is device-independent assures its scalability to future PCIe parts from IDT. Once users are familiar with the GUI, they will be able to use the same GUI on all PCIe parts from IDT. This software is customized for each device through an XML device description file which includes information on the number of ports, registers, types of registers, information on bit-fields within each register, etc.

Notes



Schematics

Notes

Schematics

89EBPES24T6G2 – 89HPES24T6G2 Evaluation Board

REVISIONS				
DCN	REV	DESCRIPTION	DATE	CHANGE BY
PCB-0147R01	1.0	INITIAL RELEASE	2008-01-16	K. LEUNG

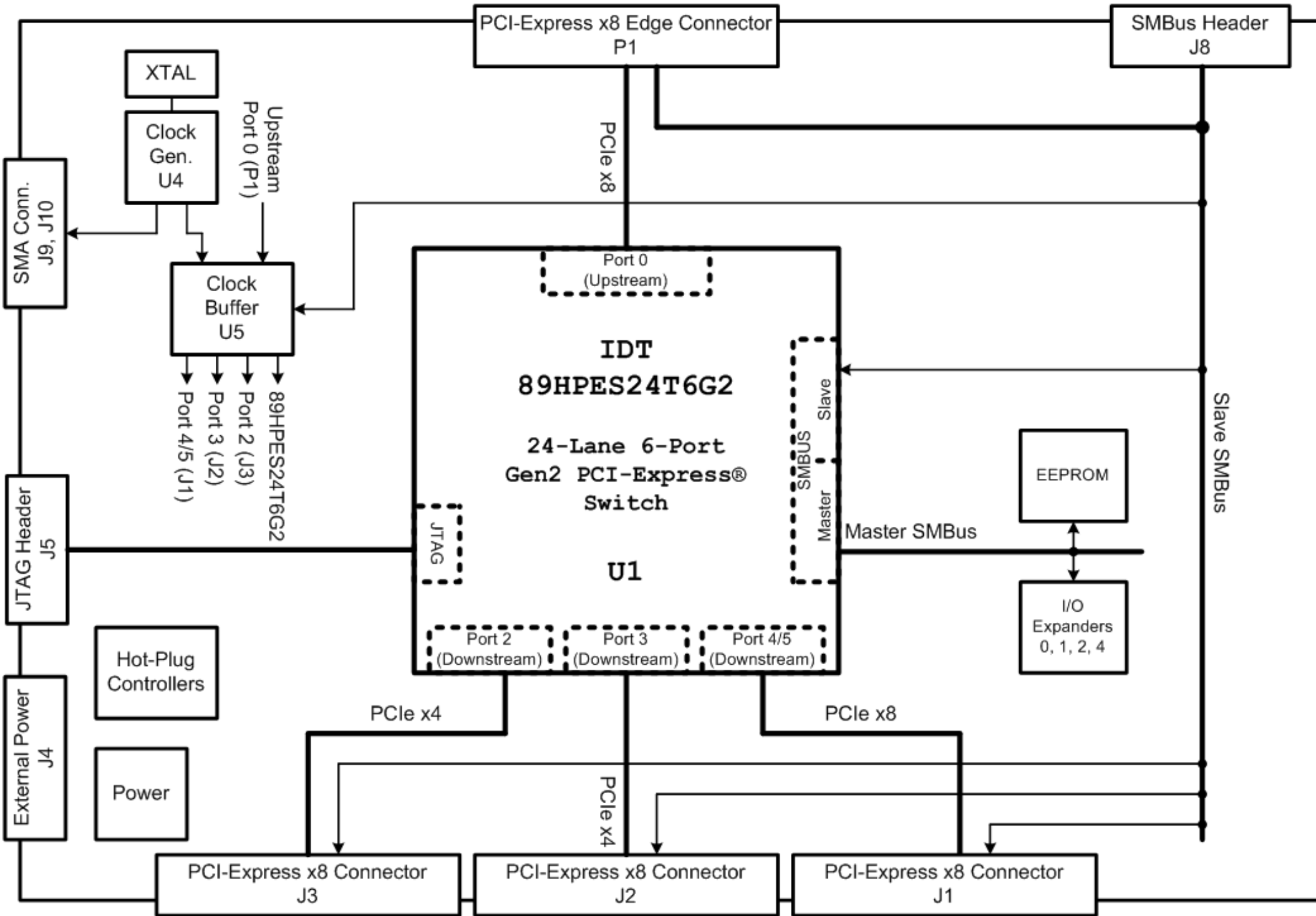

SHEET DESCRIPTION

- 1 TITLE PAGE
- 2 RESET, POWER CONNECTOR
- 3 POWER REGULATORS
- 4 CLOCKS
- 5 I/O EXP, WAKE, ATTN
- 6 HOT PLUG CONTROLLERS
- 7 HOT PLUG – MOSFETS
- 8 PORT 0 EDGE CONN (U/S)
- 9 PORT 2 CONNECTOR (D/S)
- 10 PORT 3 CONNECTOR (D/S)
- 11 PORT 4 CONNECTOR (D/S)
- 12 PES24T6G2 – EEPROM, JTAG
- 13 PES24T6G2 – POWER



CONFIDENTIAL PROPERTY OF INTEGRATED DEVICE TECHNOLOGY, INC.
6024 SILVER CREEK VALLEY RD. SAN JOSE, CA 95138
COPYRIGHT (C) IDT2007

TITLE 89EBPES24T6G2			
SIZE B	DRAWING NO. SCH-00145	FAB P/N 18-656-000	REV. 1.0
AUTHOR M Shen / K Leung		CHECKED BY D Huang	
Wed Jan 16 11:59:17 2008			SHEET 1 OF 13

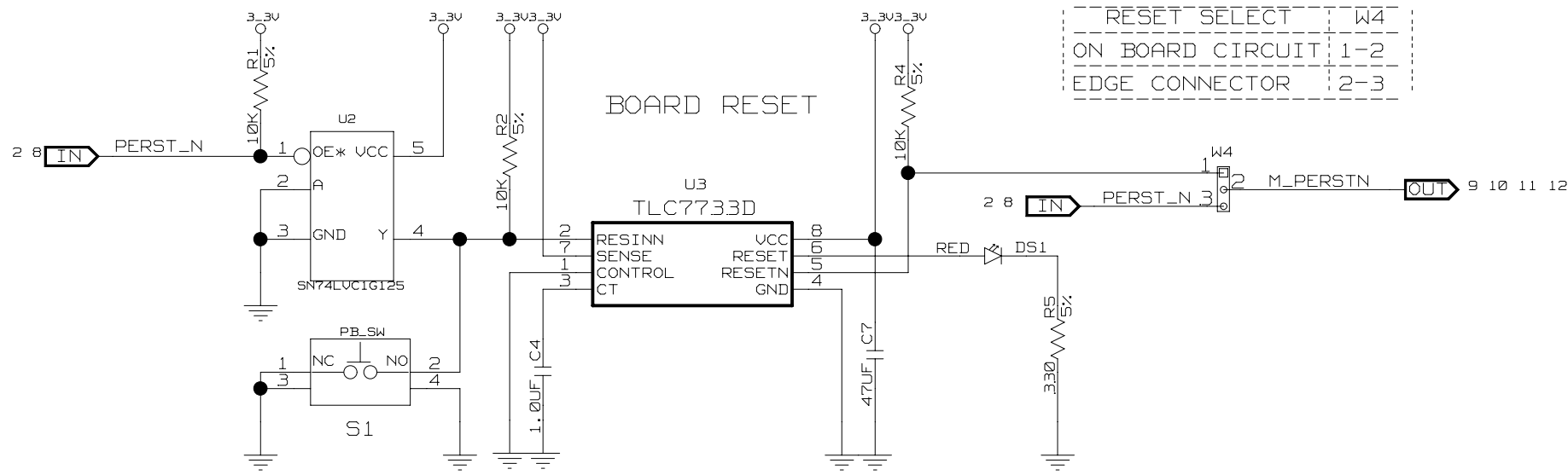

SILKSCREEN TABLE

RESET SELECT	W4
ON BOARD CIRCUIT	1-2
EDGE CONNECTOR	2-3

POWER INDICATOR
PLACE NEAR TOP EDGE
LABEL 'POWER'

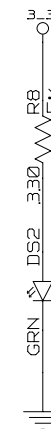

LABEL 'GND'

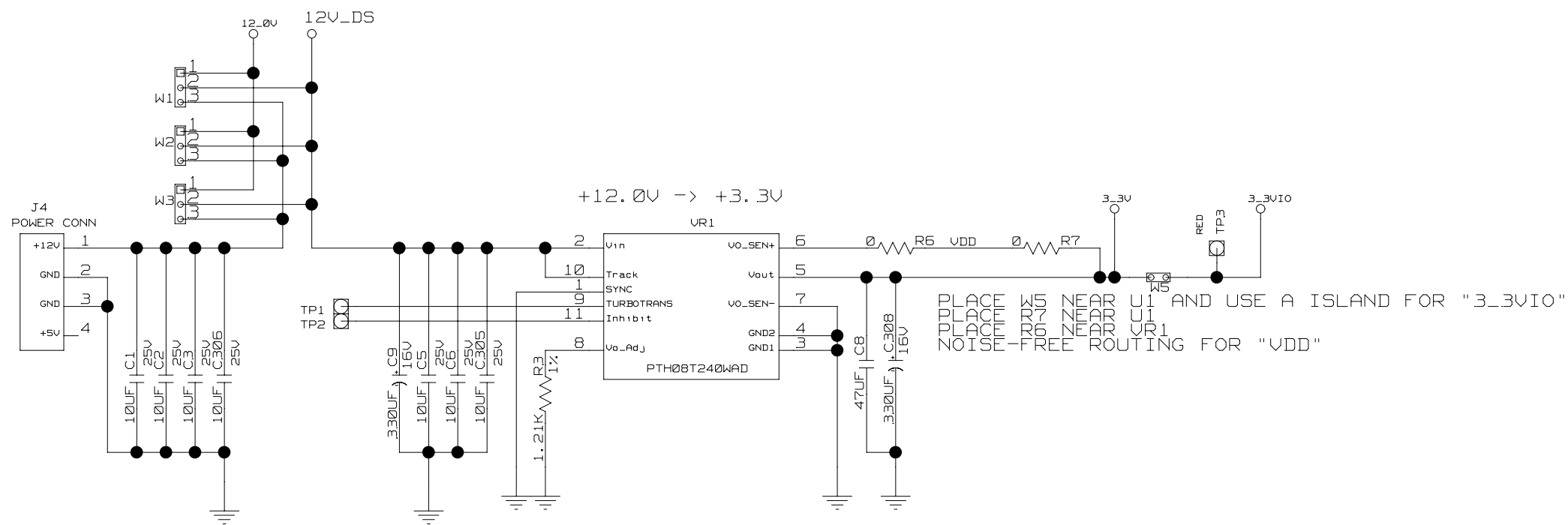
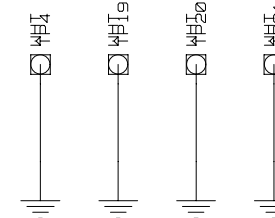

PLACE THIS LABEL NEAR THE 3.3VIO AND USE A ISLAND FOR "3.3VIO"
NOISE-FREE ROUTING FOR "VDD"

SILKSCREEN TABLE

12V POWER SELECT	W1	W2	W3
EDGE CONNECTOR	1-2	1-2	1-2
EXTERNAL INPUT	2-3	2-3	2-3



CONFIDENTIAL PROPERTY OF INTEGRATED DEVICE TECHNOLOGY, INC.
6024 SILVER CREEK VALLEY RD. SAN JOSE, CA 95138
COPYRIGHT (C) IDT2007

TITLE 89EBPES24T6G2

RESET, POWER CONNECTOR

SIZE	DRAWING NO.	FAB P/N	REV.
B	SCH-00145	18-656-000	1.0

AUTHOR	CHECKED BY
M Shen / K Leung	D Huang

Wed Jan 09 11:31:55 2008 SHEET 2 OF 13

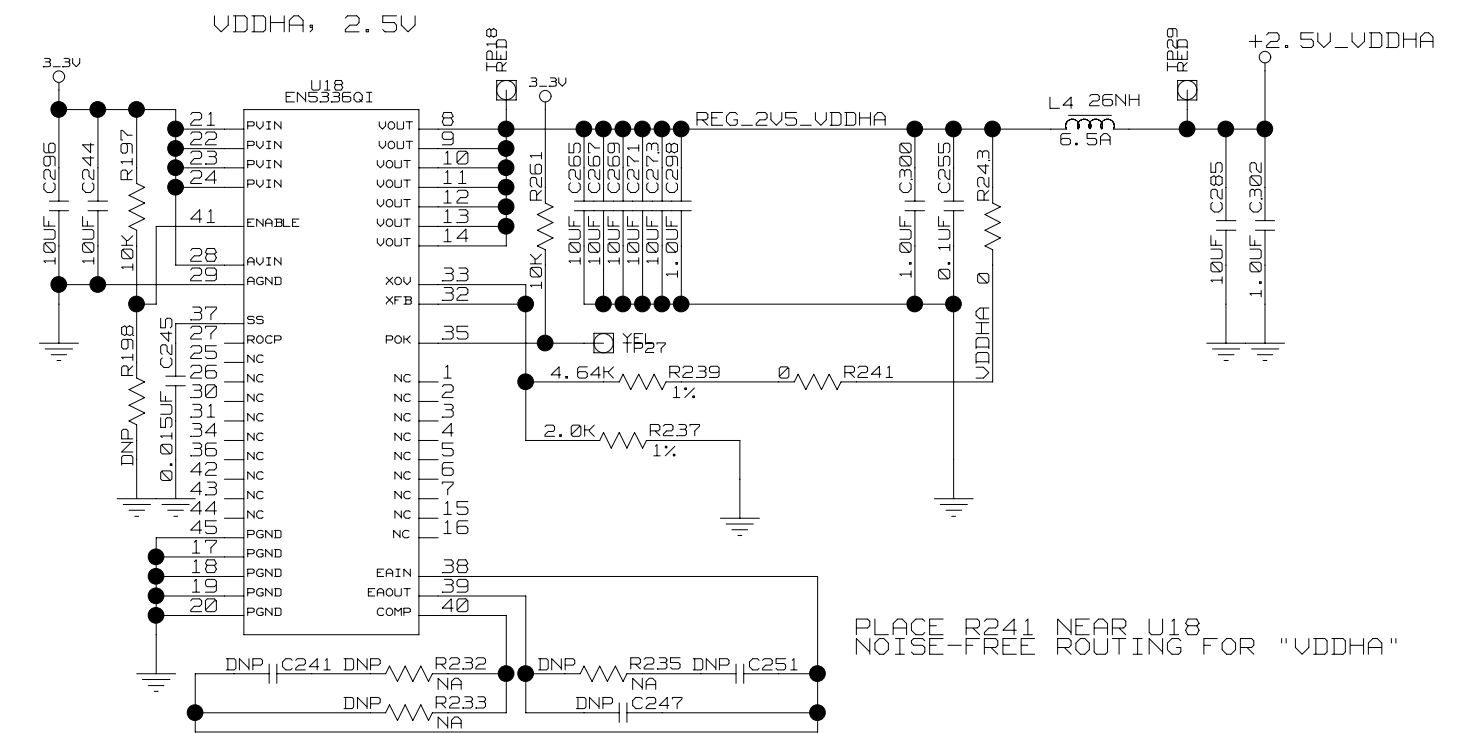
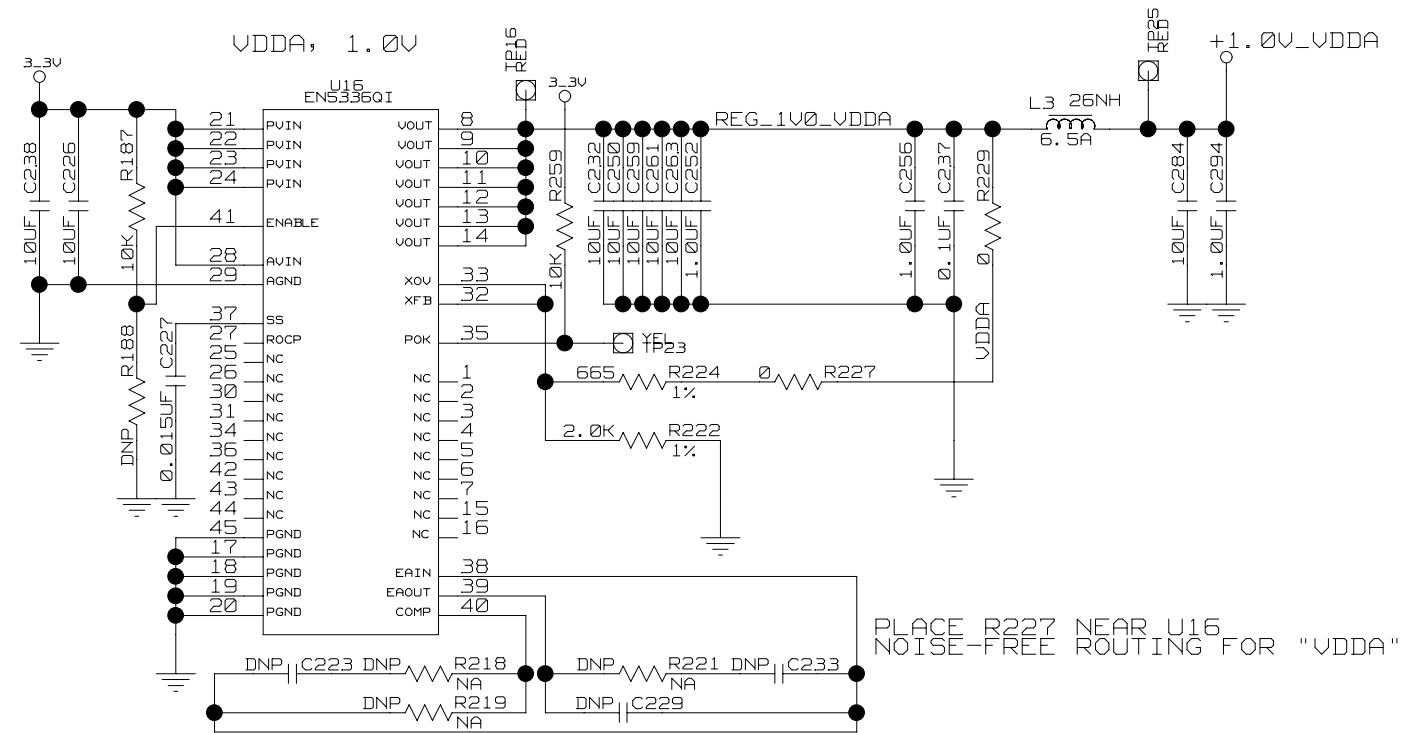
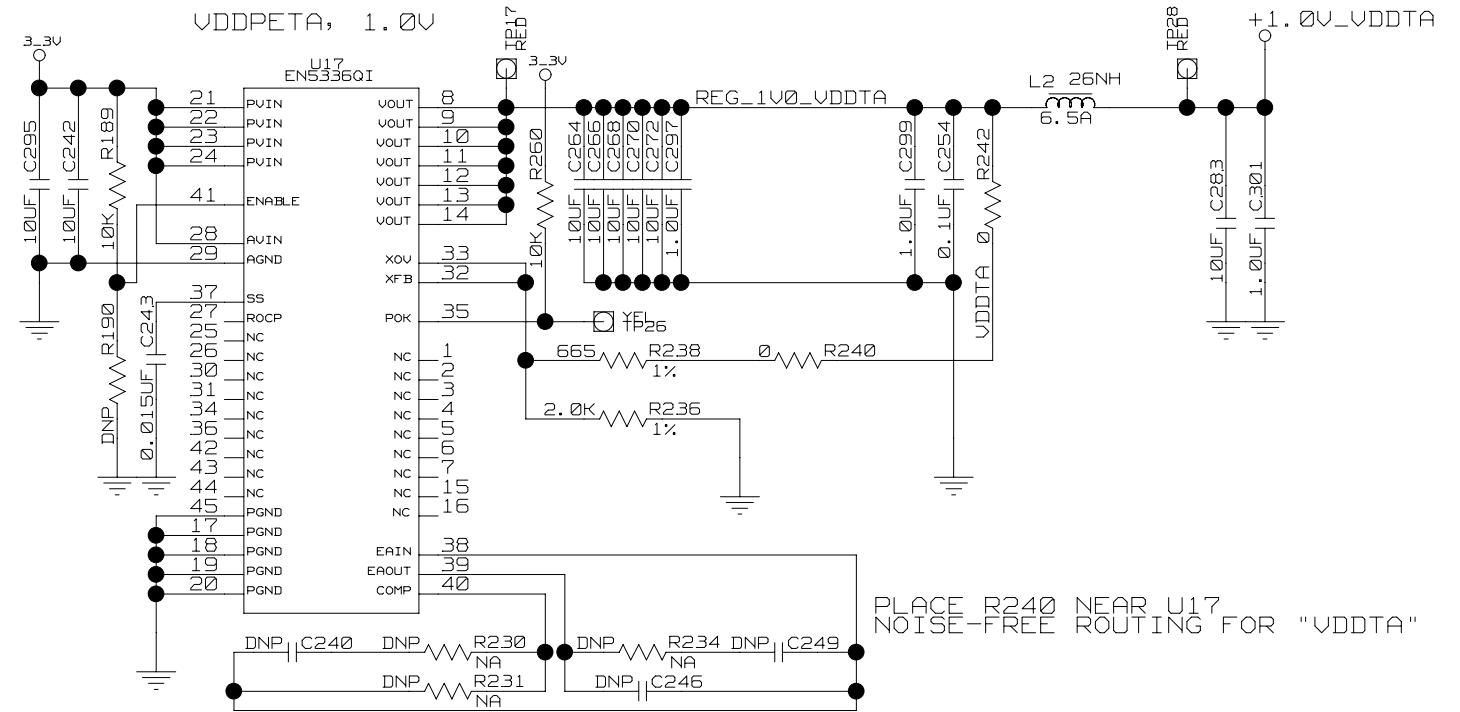
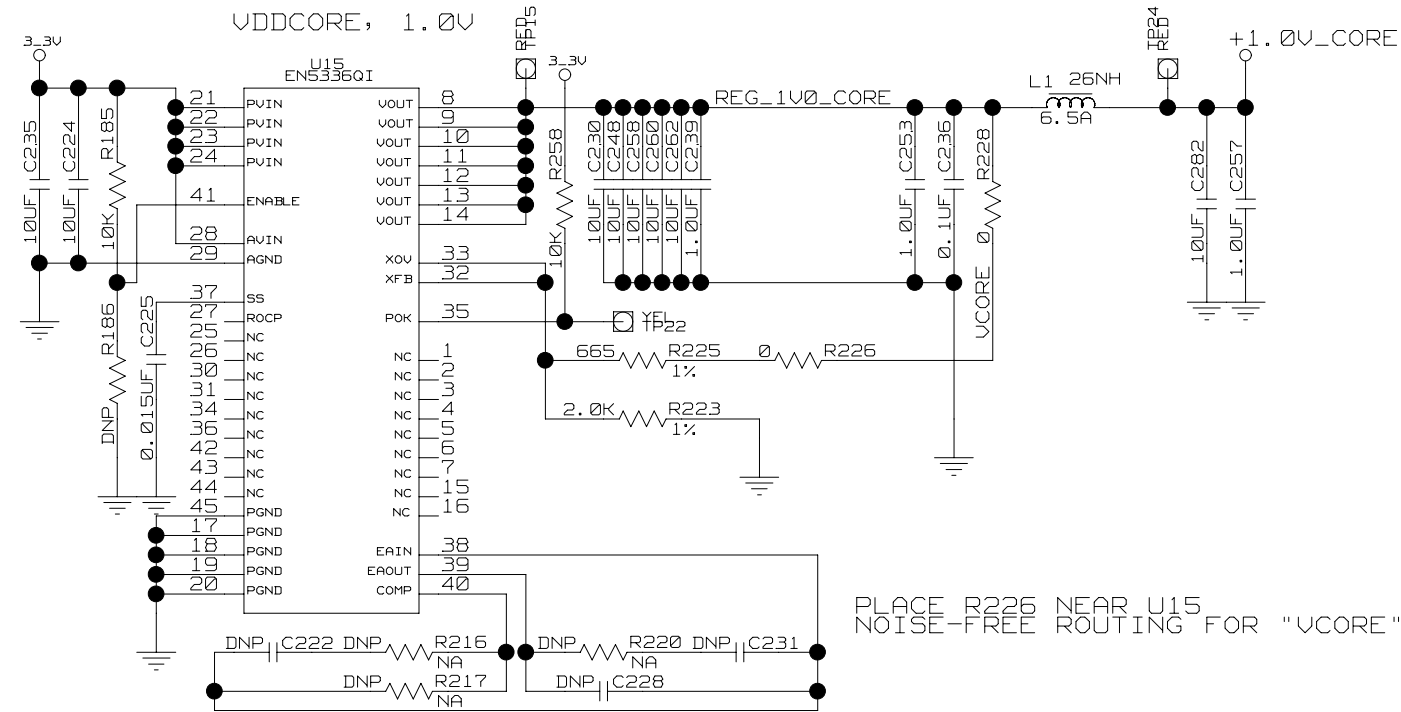

NOTE:
ALL POWER NETS USE PLANE OR WIDE TRACE



CONFIDENTIAL PROPERTY OF INTEGRATED DEVICE TECHNOLOGY, INC.
6024 SILVER CREEK VALLEY RD. SAN JOSE, CA 95138
COPYRIGHT (C) IDT2007

TITLE 89EBPES24T6G2

POWER REGULATORS

SIZE B	DRAWING NO. SCH-00145	FAB P/N 18-656-000	REV. 1.0
AUTHOR M Shen / K Leung		CHECKED BY D Huang	
Wed Jan 09 11:31:54 2008			SHEET 3 OF 13

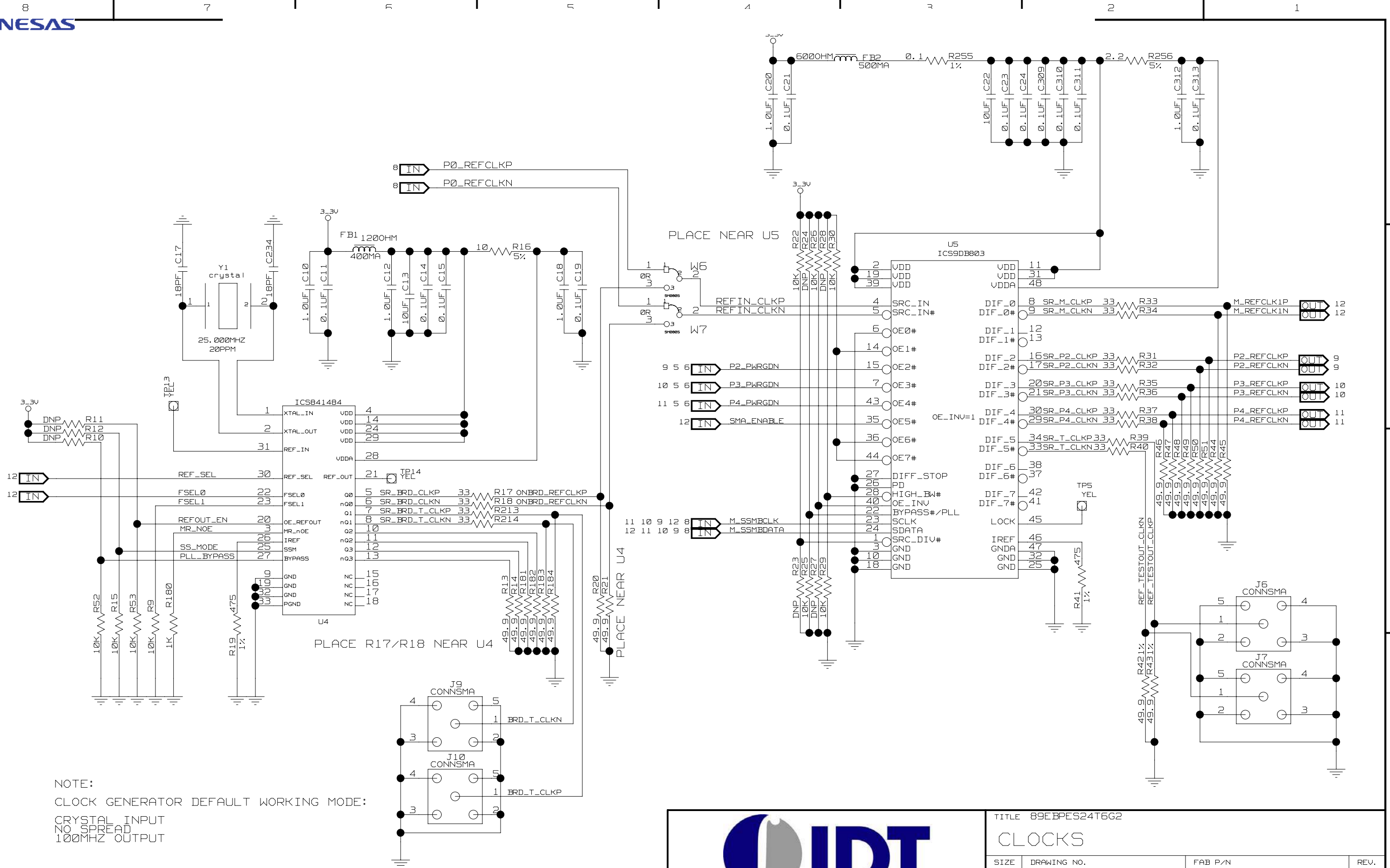

NOTE:
 CLOCK GENERATOR DEFAULT WORKING MODE:
 CRYSTAL INPUT
 NO SPREAD
 100MHZ OUTPUT

CONFIDENTIAL PROPERTY OF INTEGRATED DEVICE TECHNOLOGY, INC.
 6024 SILVER CREEK VALLEY RD. SAN JOSE, CA 95138
 COPYRIGHT (C) IDT2007

TITLE 89EBPES24T6G2			
CLOCKS			
SIZE	DRAWING NO.	FAB P/N	REV.
B	SCH-00145	18-656-000	1.0
AUTHOR		CHECKED BY	
M Shen / K Leung		D Huang	
Wed Jan 09 11:31:55 2008			SHEET 4 OF 13

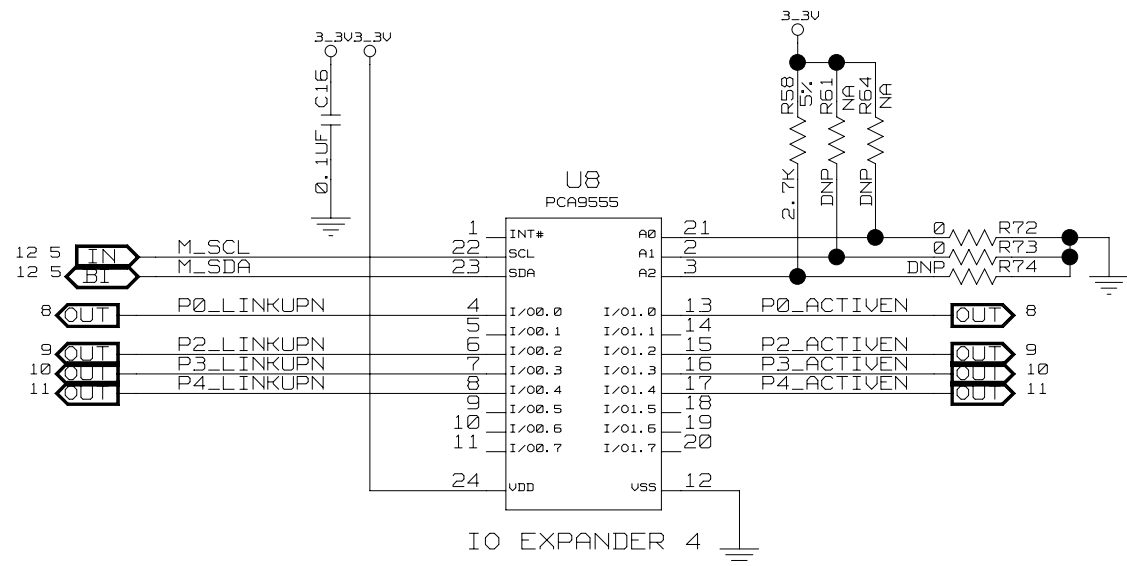
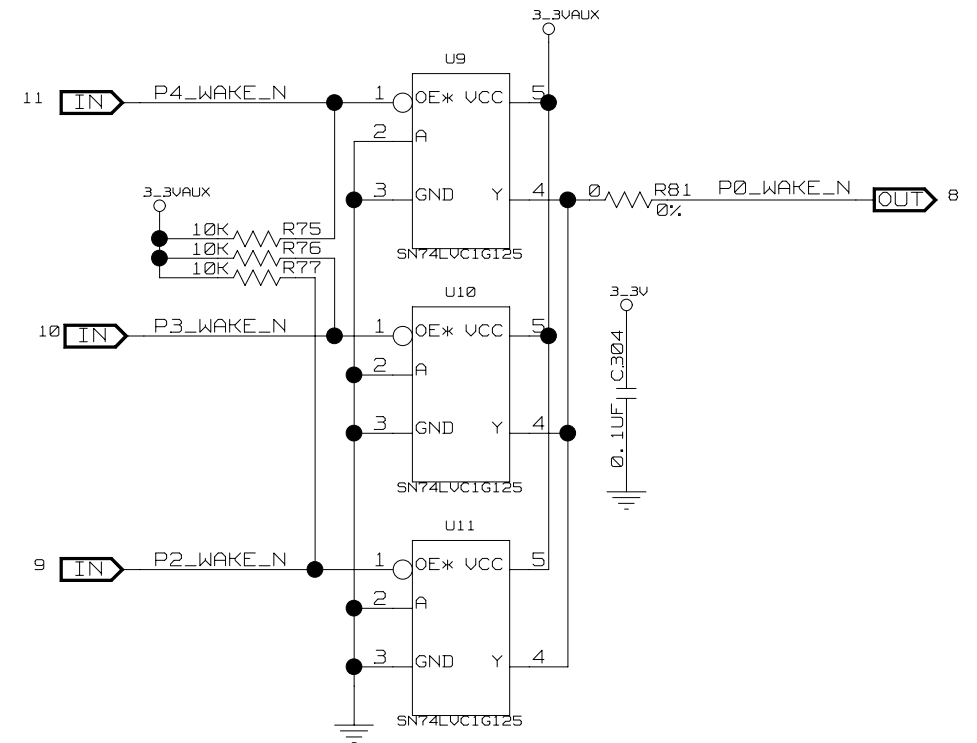
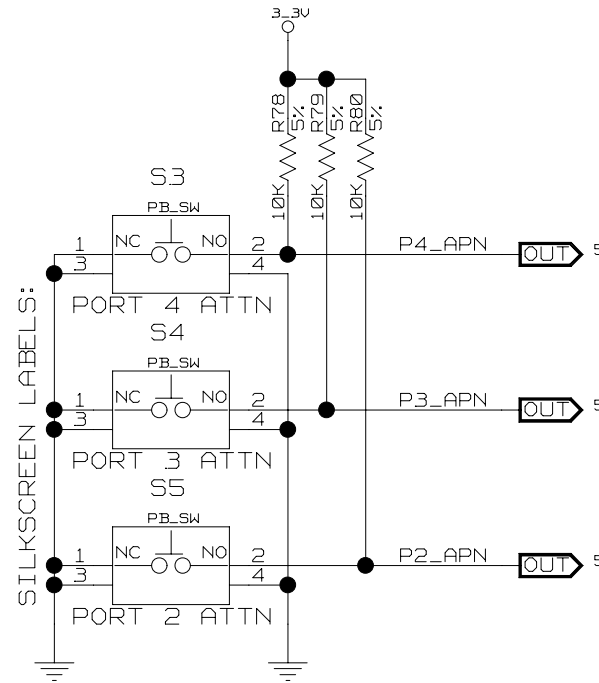
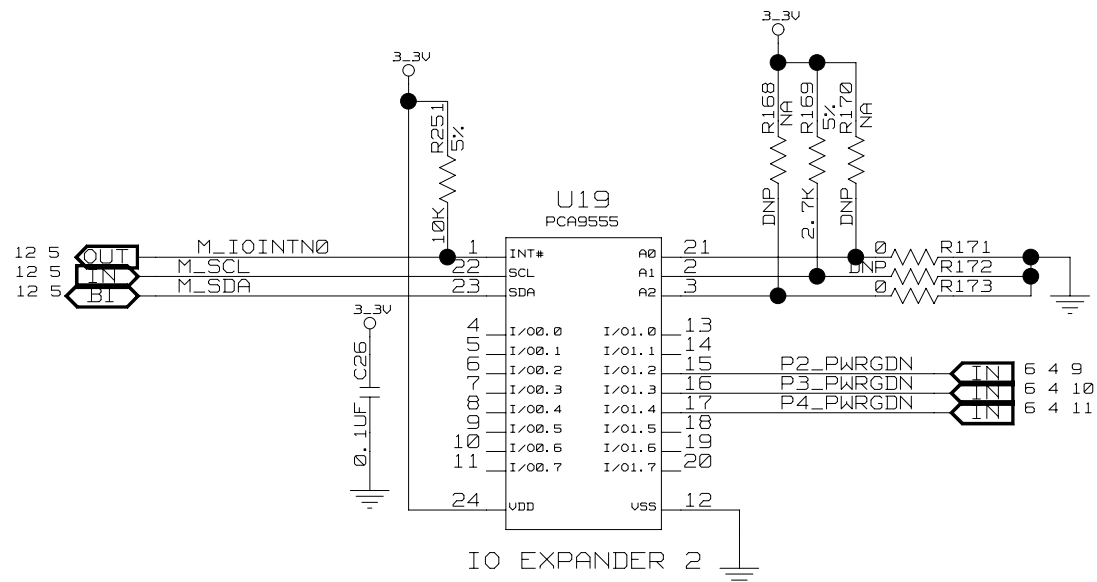
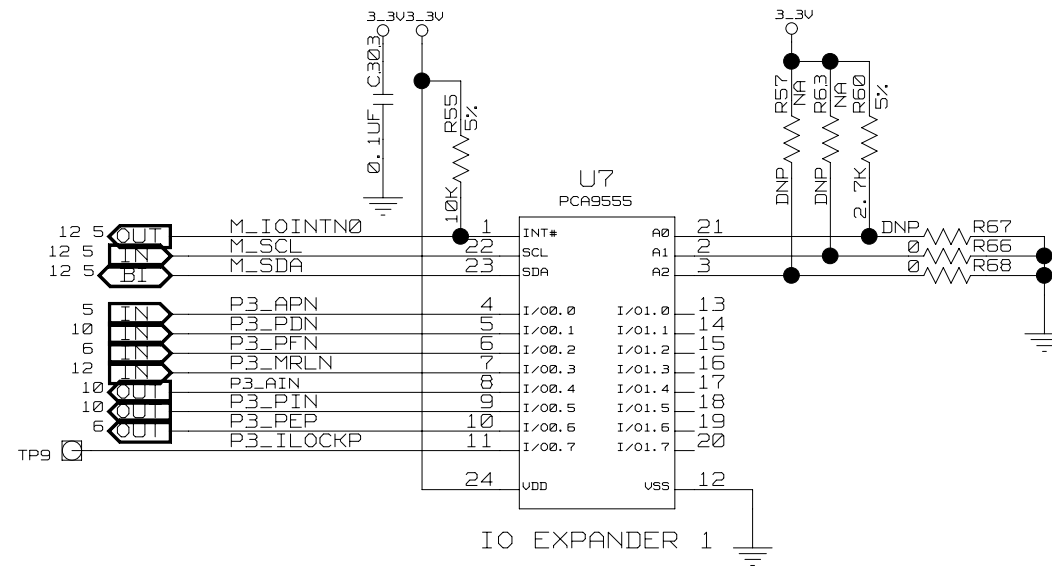
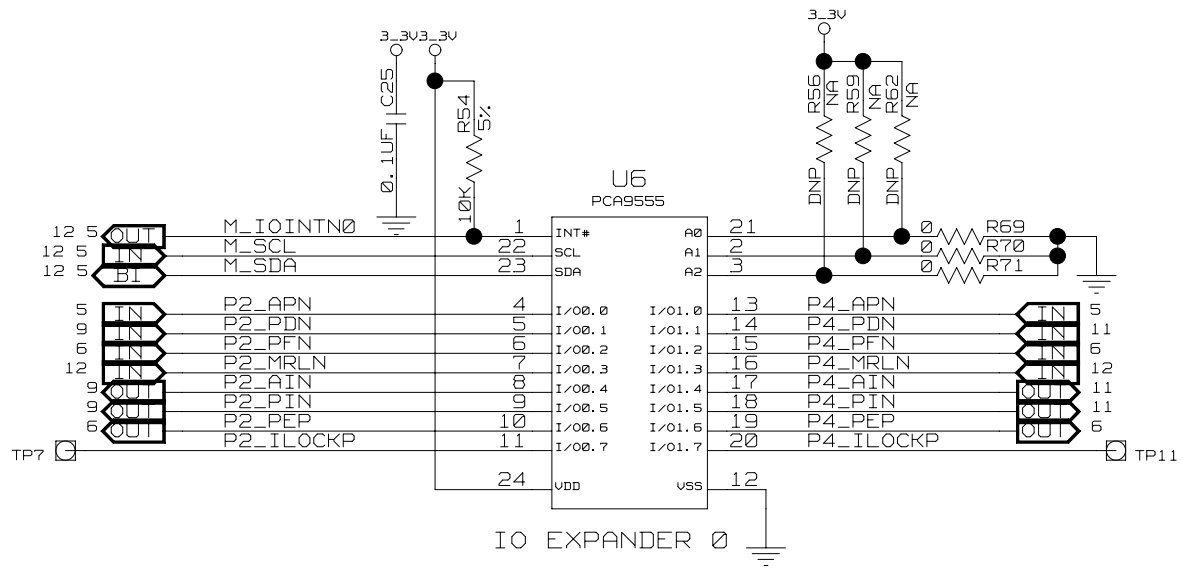

CONFIDENTIAL PROPERTY OF INTEGRATED DEVICE TECHNOLOGY, INC.
6024 SILVER CREEK VALLEY RD. SAN JOSE, CA 95138
COPYRIGHT (C) IDT2007

TITLE 89EBPES24T6G2			
IO EXP, WAKE, ATTN BUTTONS			
SIZE	DRAWING NO.	FAB P/N	REV.
B	SCH-00145	18-656-000	1.0
AUTHOR		CHECKED BY	
M Shen / K Leung		D Huang	
Wed Jan 09 11:31:56 2008			SHEET 5 OF 13

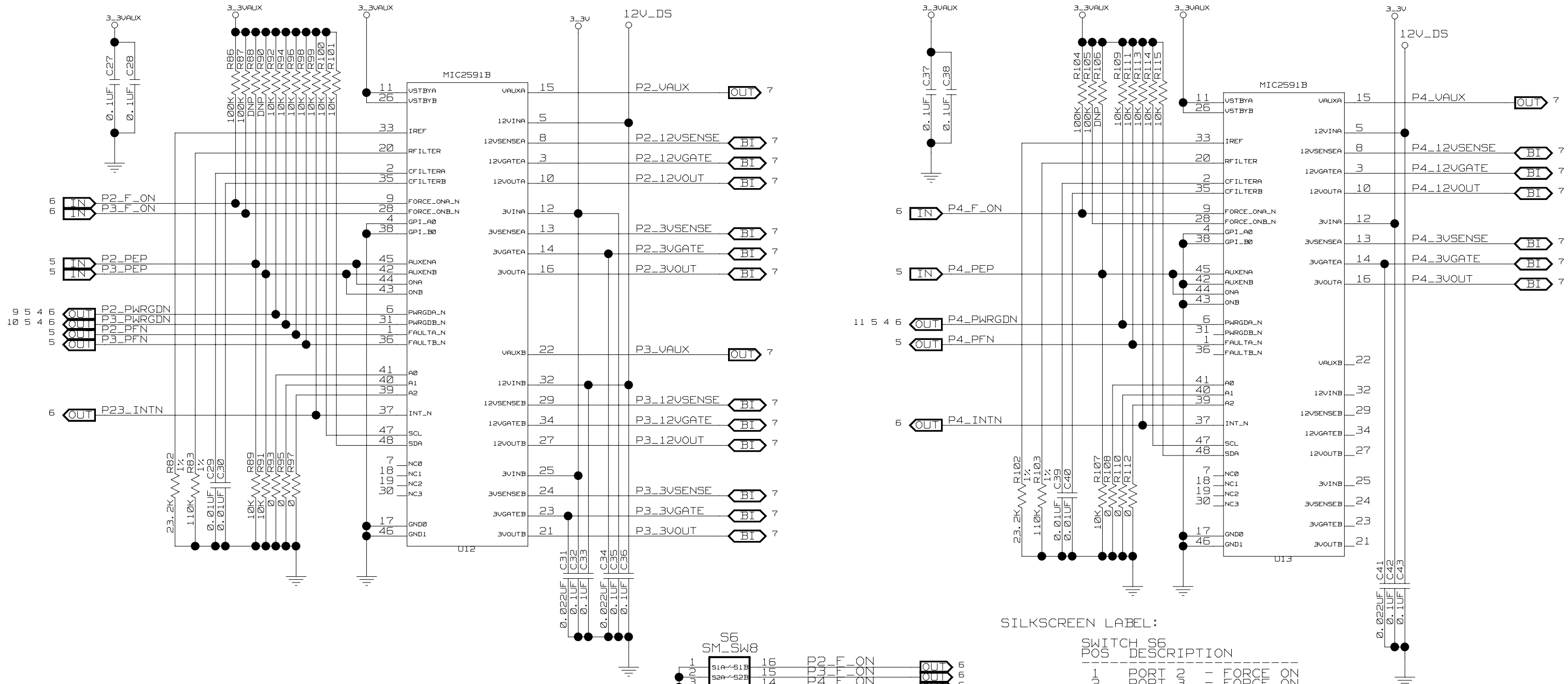

SILKSCREEN LABEL:

POS	DESCRIPTION
1	FORCE ON
2	FORCE ON
3	FORCE ON
4	FORCE ON
5	GOOD
6	GOOD
7	GOOD
8	GOOD
9	GOOD
10	GOOD
11	GOOD

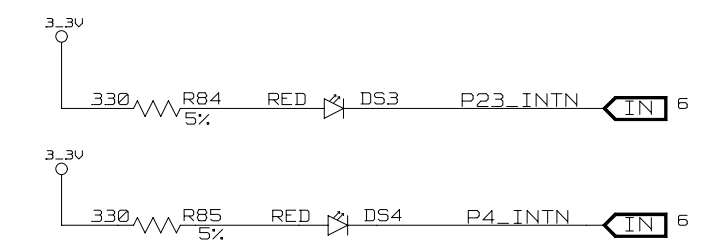
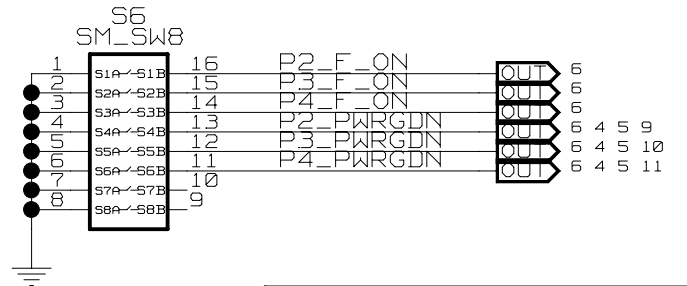

IDT

CONFIDENTIAL PROPERTY OF INTEGRATED DEVICE TECHNOLOGY, INC.
6024 SILVER CREEK VALLEY RD. SAN JOSE, CA 95138
COPYRIGHT (C) IDT2007

TITLE 89EBPES24T6G2			
HOT PLUG CONTROLLERS			
SIZE	DRAWING NO.	FAB P/N	REV.
B	SCH-00145	18-656-000	1.0
AUTHOR		CHECKED BY	
M Shen / K Leung		D Huang	
Wed Jan 09 11:31:56 2008			SHEET 6 OF 13

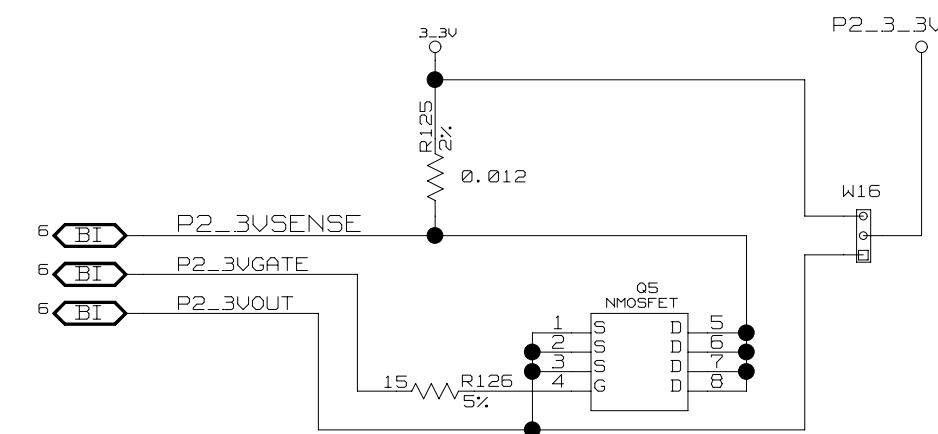
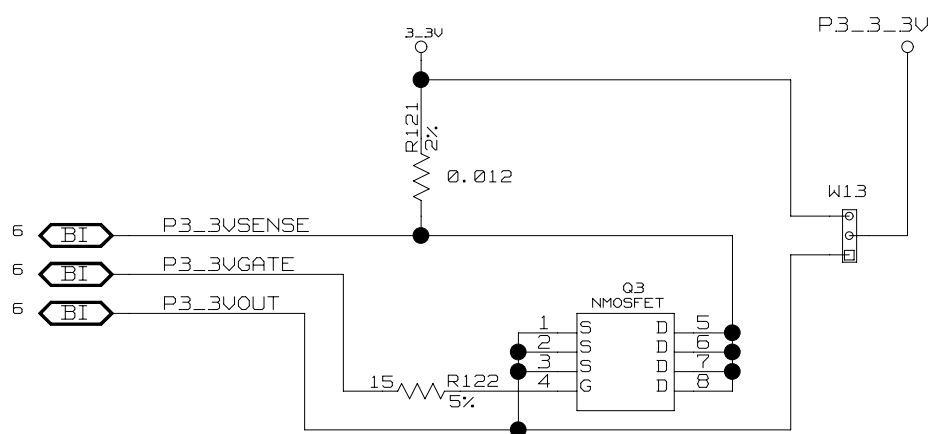
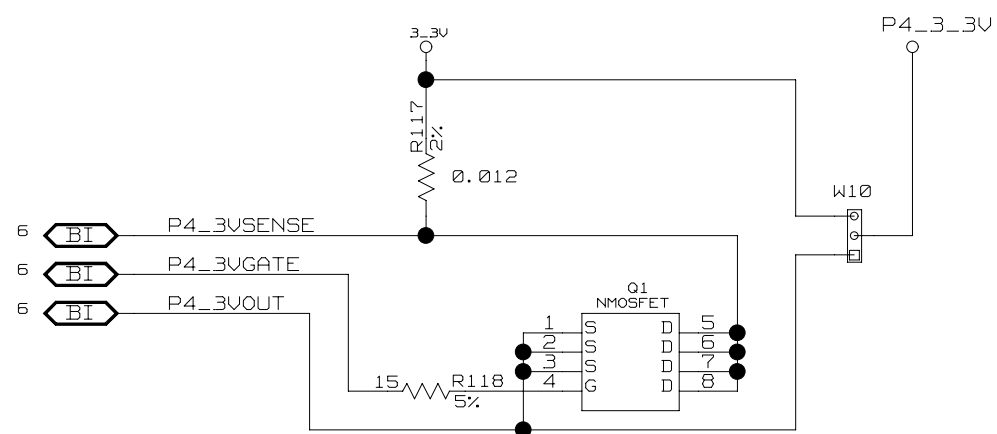
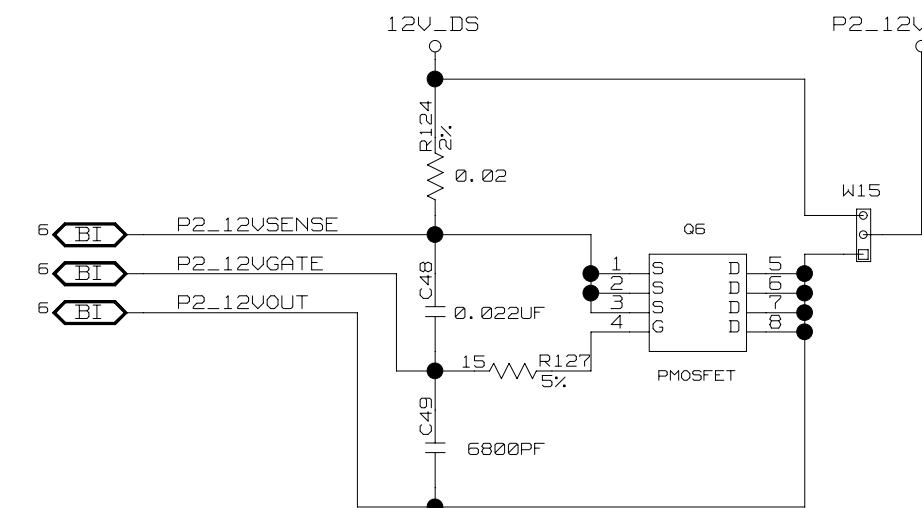
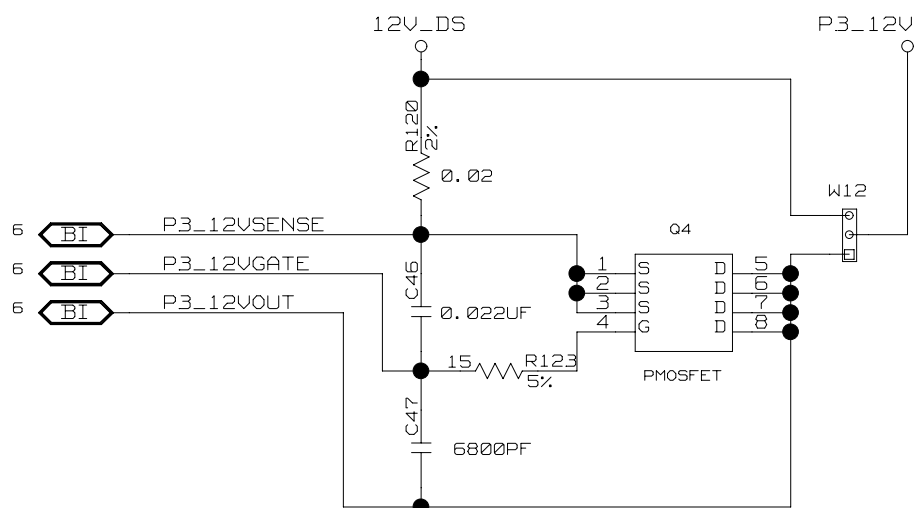
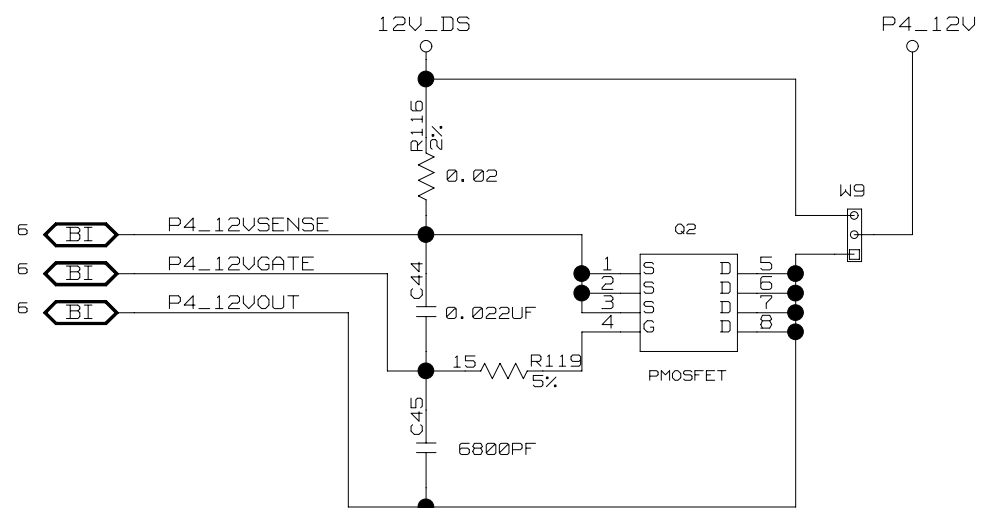
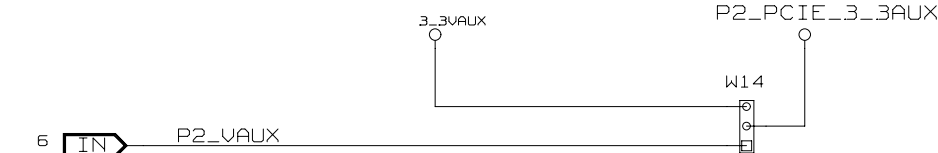
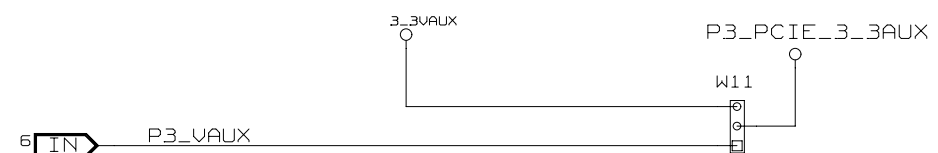
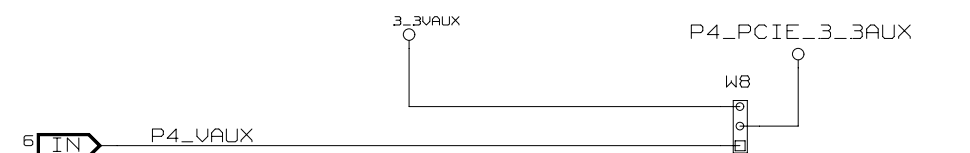

NOTE; USE PLANES OR WIDE TRACES FOR ALL POWER NETS



CONFIDENTIAL PROPERTY OF INTEGRATED DEVICE TECHNOLOGY, INC.
6024 SILVER CREEK VALLEY RD. SAN JOSE, CA 95138
COPYRIGHT (C) IDT2007

TITLE 89EBPES24T6G2			
HOT PLUG - MOSFETS			
SIZE B	DRAWING NO. SCH-00145	FAB P/N 18-656-000	REV. 1.0
AUTHOR M Shen / K Leung		CHECKED BY D Huang	
Wed Jan 09 11:31:57 2008			SHEET 7 OF 13

LABEL PINS:

4 SMBDATA
 11 GND
 10 SMBCLK
 9 NC
 12

11 10 9 4 12
 4 12 11 10 9

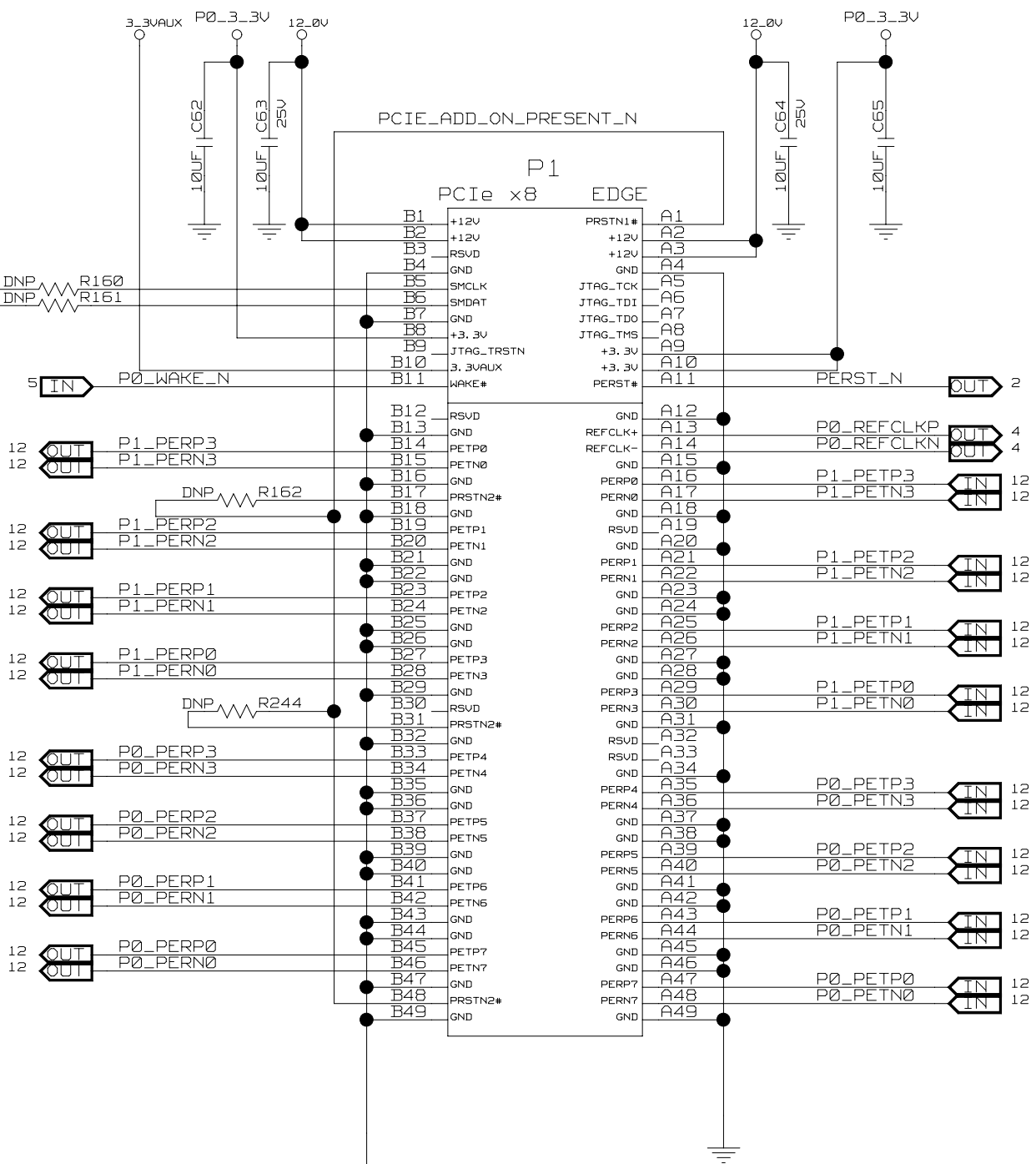
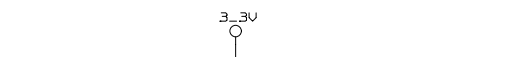
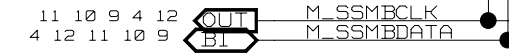

TITLE 89EBPES24T6G2			
PORT 0 UPSTREAM EDGE CONN.			
SIZE	DRAWING NO.	FAB P/N	REV.
B	SCH-00145	18-656-000	1.0
AUTHOR		CHECKED BY	
M Shen / K Leung		D Huang	
Wed Jan 09 11:31:53 2008			SHEET 8 OF 13

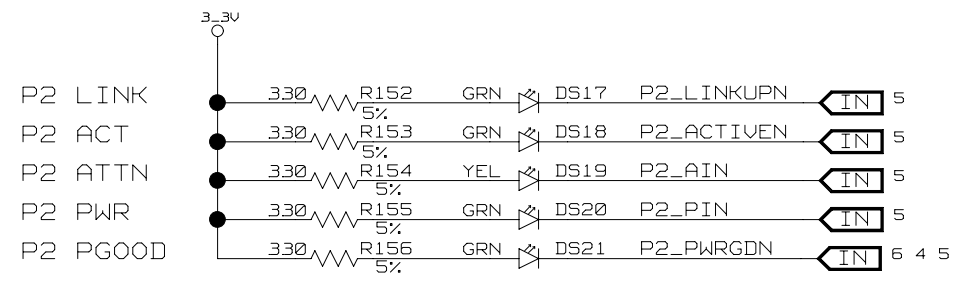
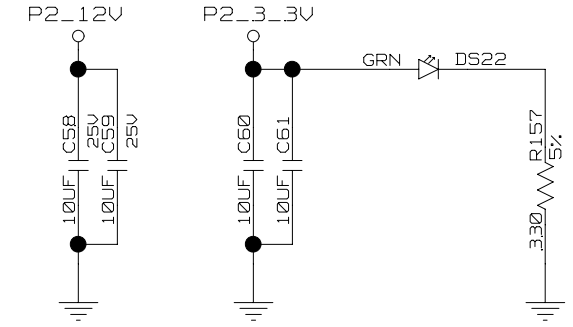
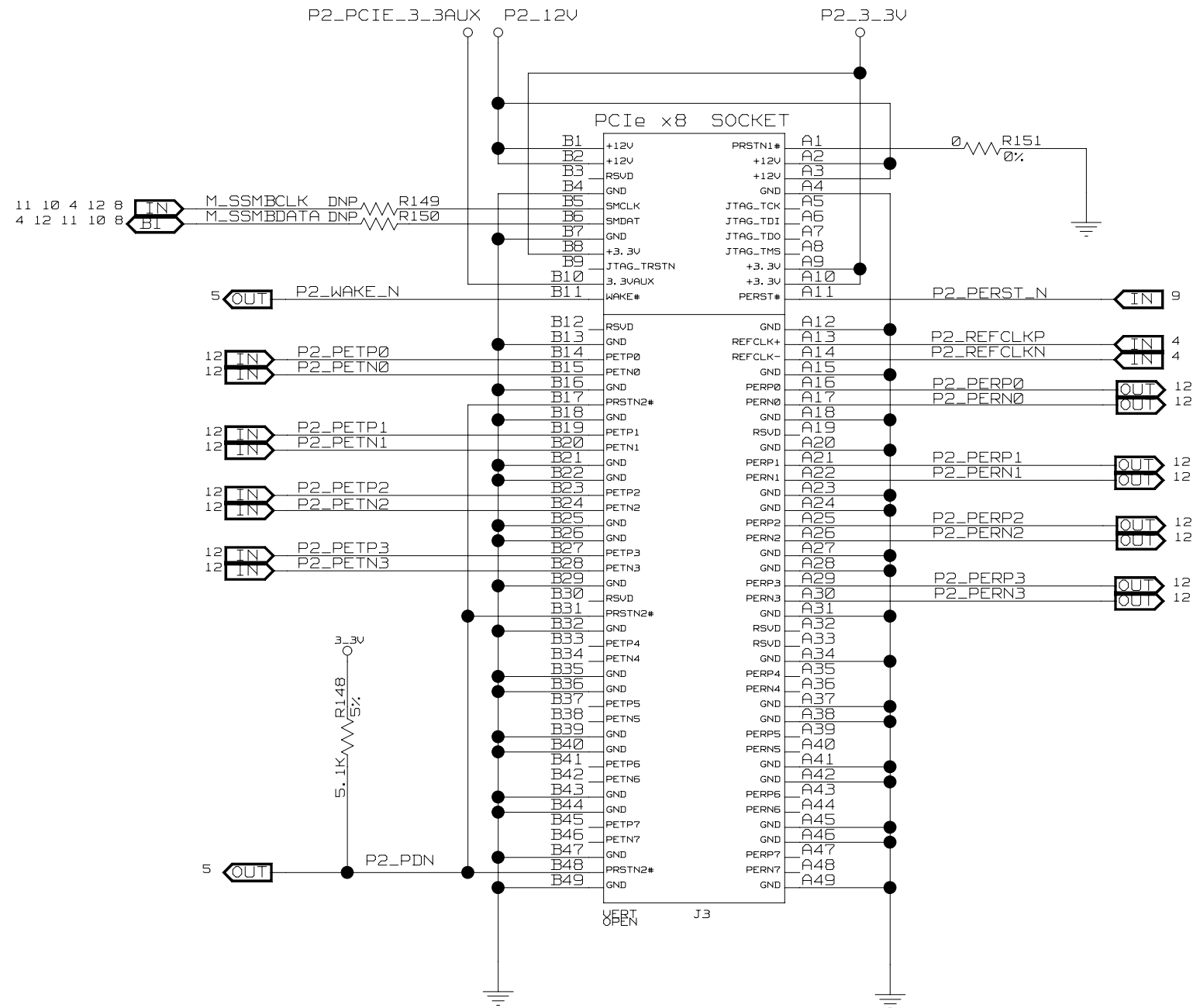

CONFIDENTIAL PROPERTY OF INTEGRATED DEVICE TECHNOLOGY, INC.
 6024 SILVER CREEK VALLEY RD. SAN JOSE, CA 95138
 COPYRIGHT (C) IDT2007

TITLE 89EBPES24T6G2			
PORT 2 CONNECTOR			
SIZE	DRAWING NO.	FAB P/N	REV.
B	SCH-00145	18-656-000	1.0
AUTHOR		CHECKED BY	
M Shen / K Leung		D Huang	
Wed Jan 09 11:31:52 2008			SHEET 9 OF 13

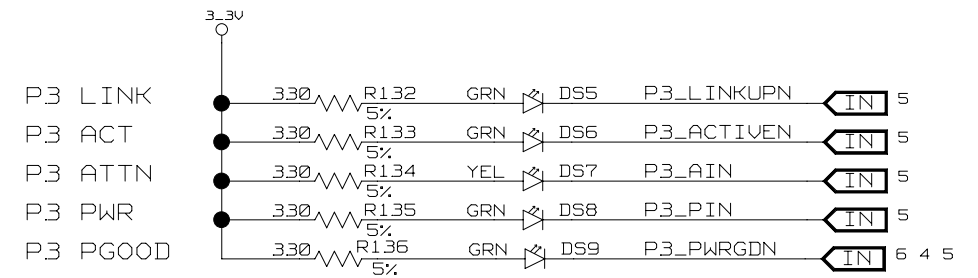
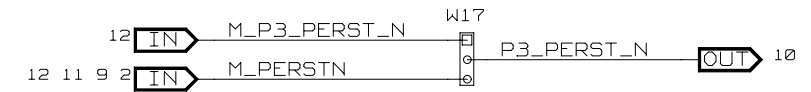
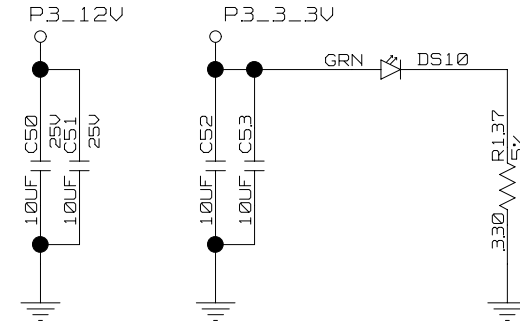
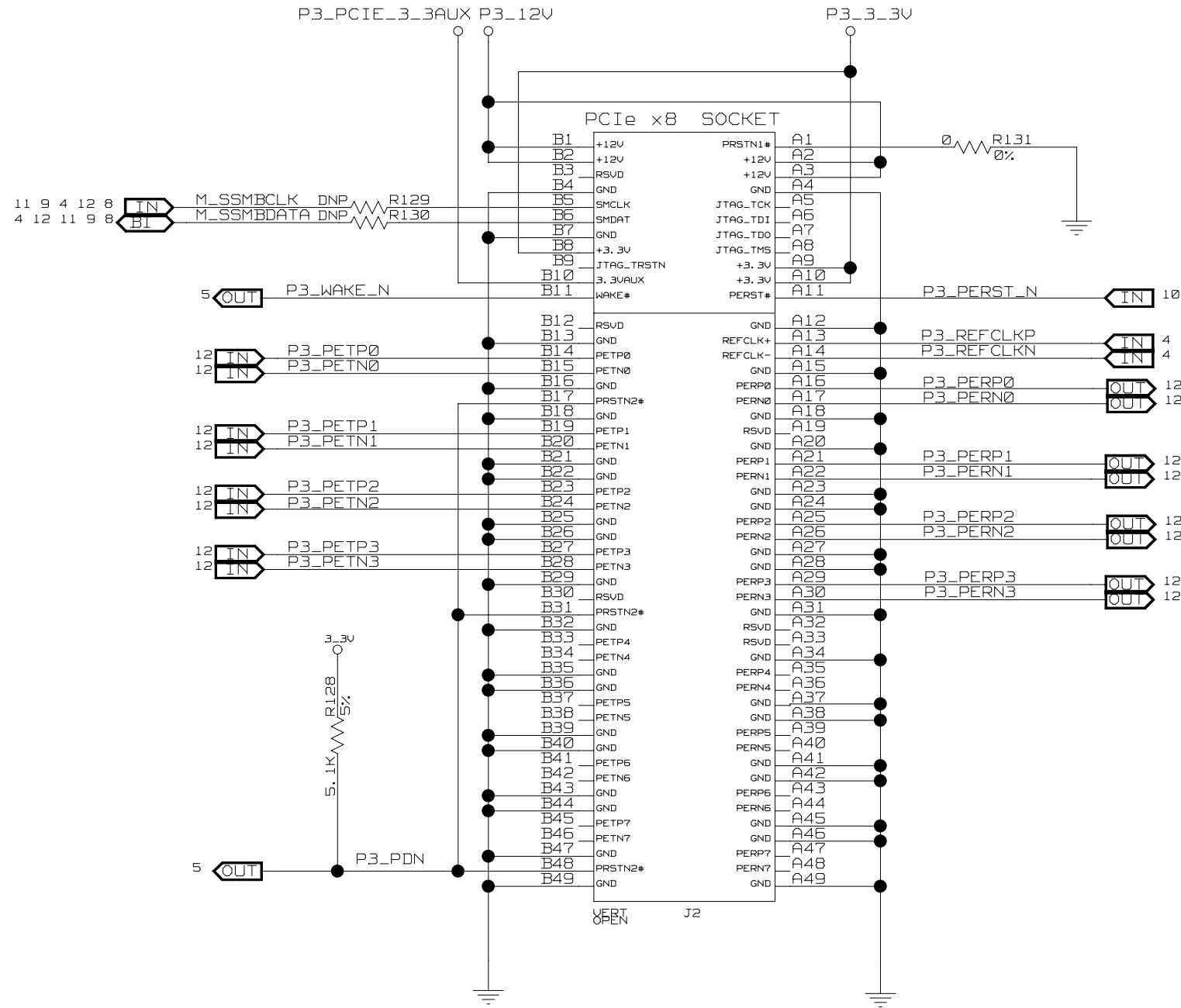

CONFIDENTIAL PROPERTY OF INTEGRATED DEVICE TECHNOLOGY, INC.
6024 SILVER CREEK VALLEY RD. SAN JOSE, CA 95138
COPYRIGHT (C) IDT2007

TITLE 89EBPES24T6G2

PORT 3 CONNECTOR

SIZE B	DRAWING NO. SCH-00145	FAB P/N 18-656-000	REV. 1.0
AUTHOR M Shen / K Leung		CHECKED BY D Huang	
Wed Jan 09 11:31:57 2008			SHEET 10 OF 13

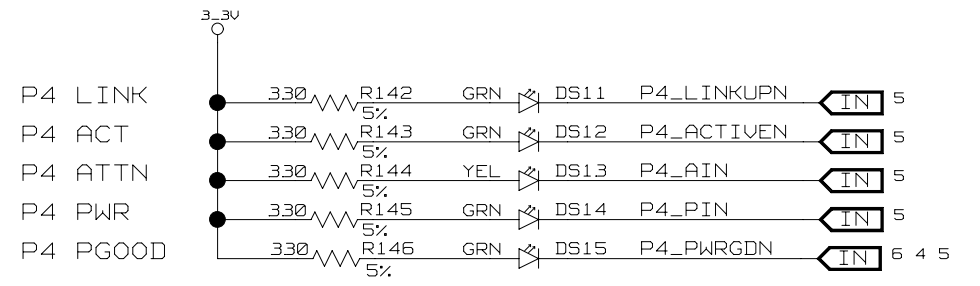
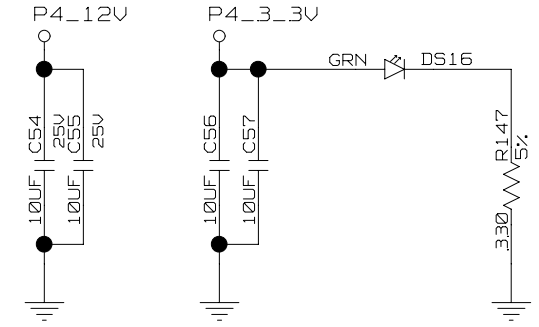
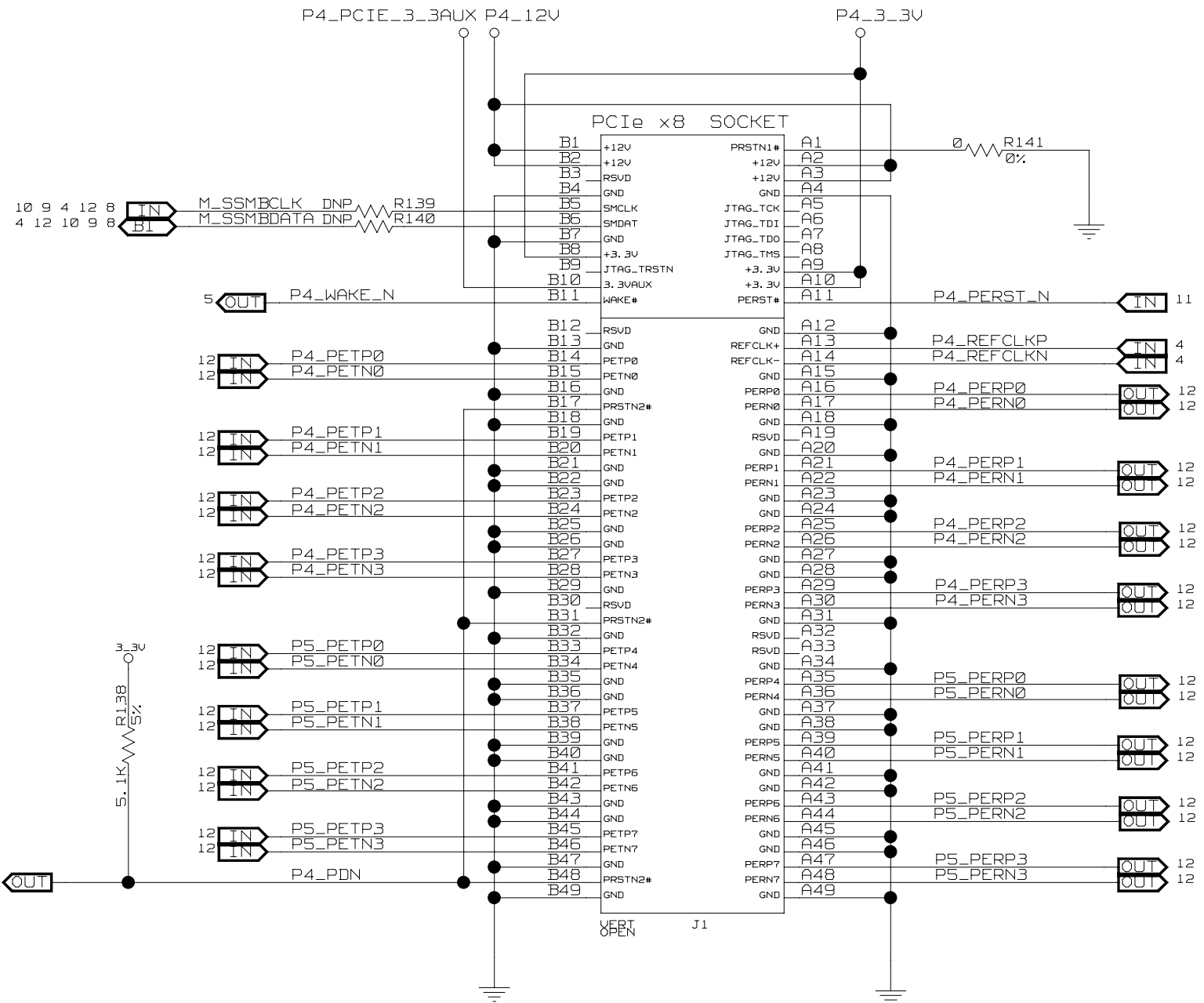

CONFIDENTIAL PROPERTY OF INTEGRATED DEVICE TECHNOLOGY, INC.
 6024 SILVER CREEK VALLEY RD. SAN JOSE, CA 95138
 COPYRIGHT (C) IDT2007

TITLE 89EBPES24T6G2			
PORT 4 CONNECTOR			
SIZE	DRAWING NO.	FAB P/N	REV.
B	SCH-00145	18-656-000	1.0
AUTHOR		CHECKED BY	
M Shen / K Leung		D Huang	
Wed Jan 09 11:31:57 2008			SHEET 11 OF 13

89HPES24T6G2 (2 of 3)

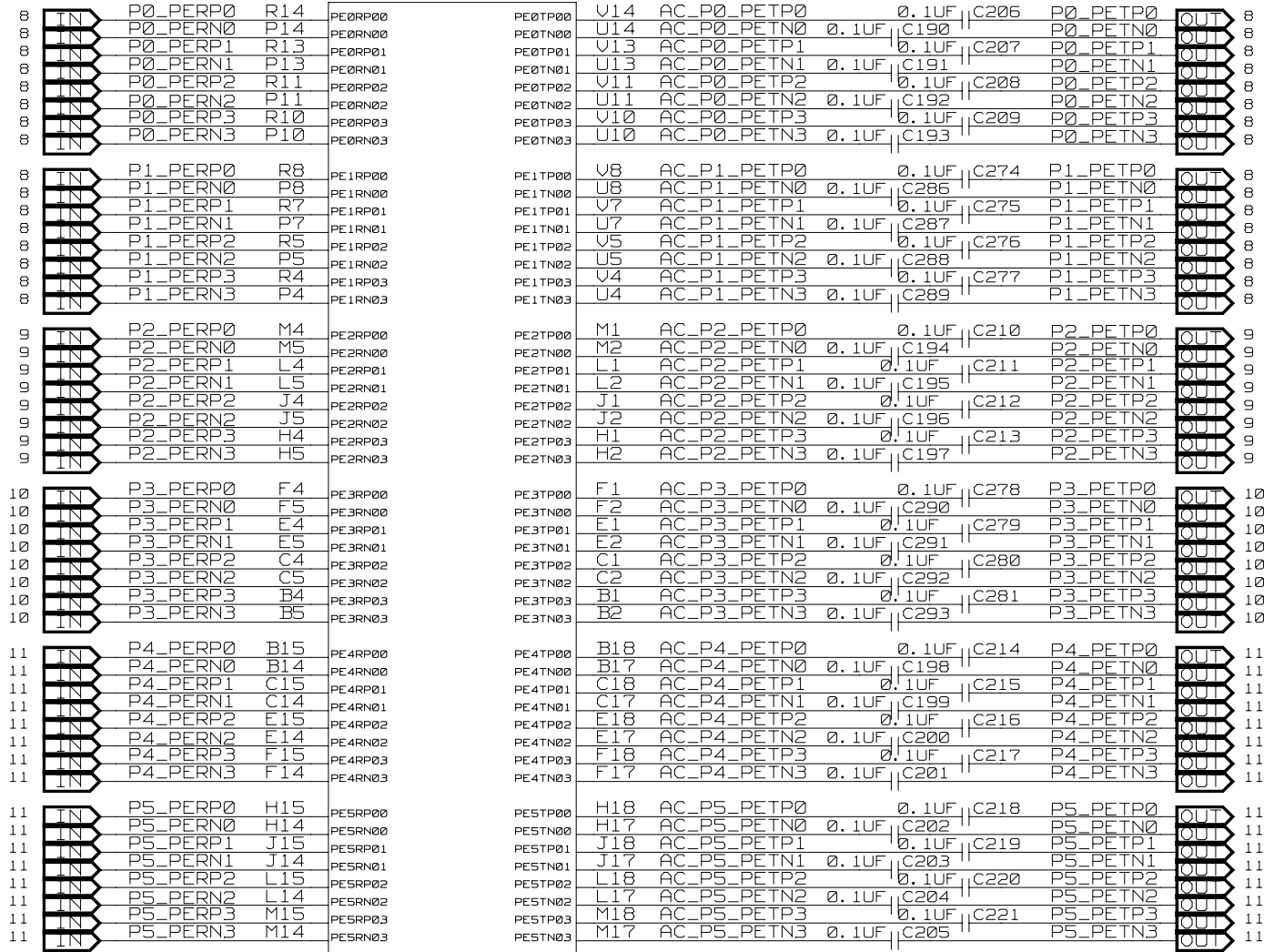

U1

NOTE:
PLACE ALL AC COUPLING CAPACITORS NEAR
EDGE CONNECTOR OR DOWNSTREAM SLOTS

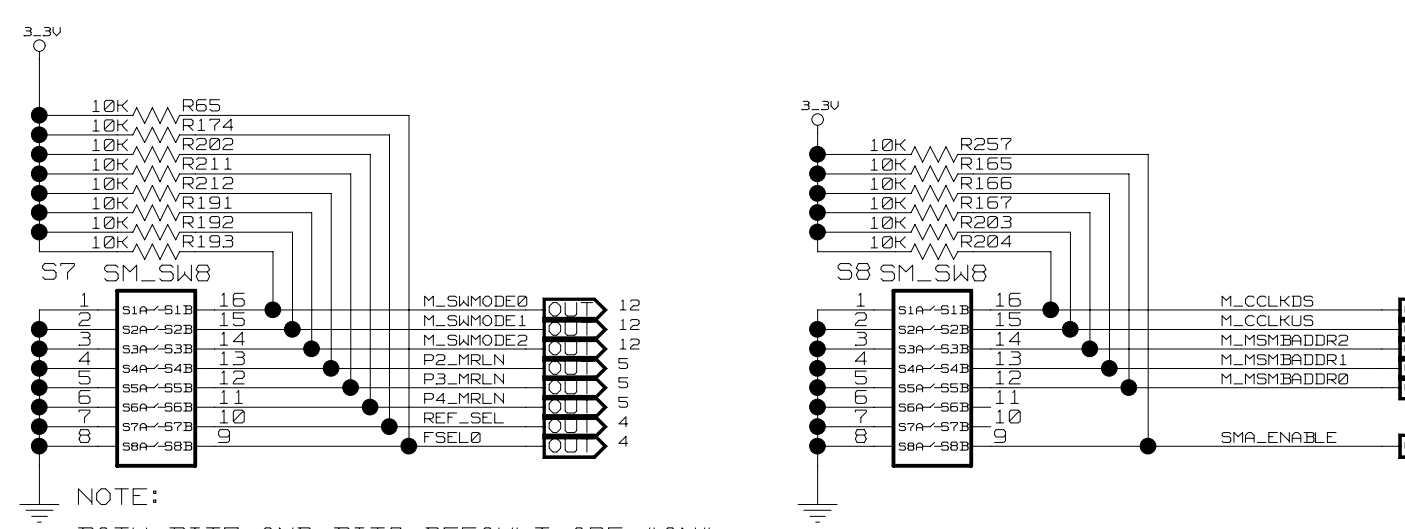
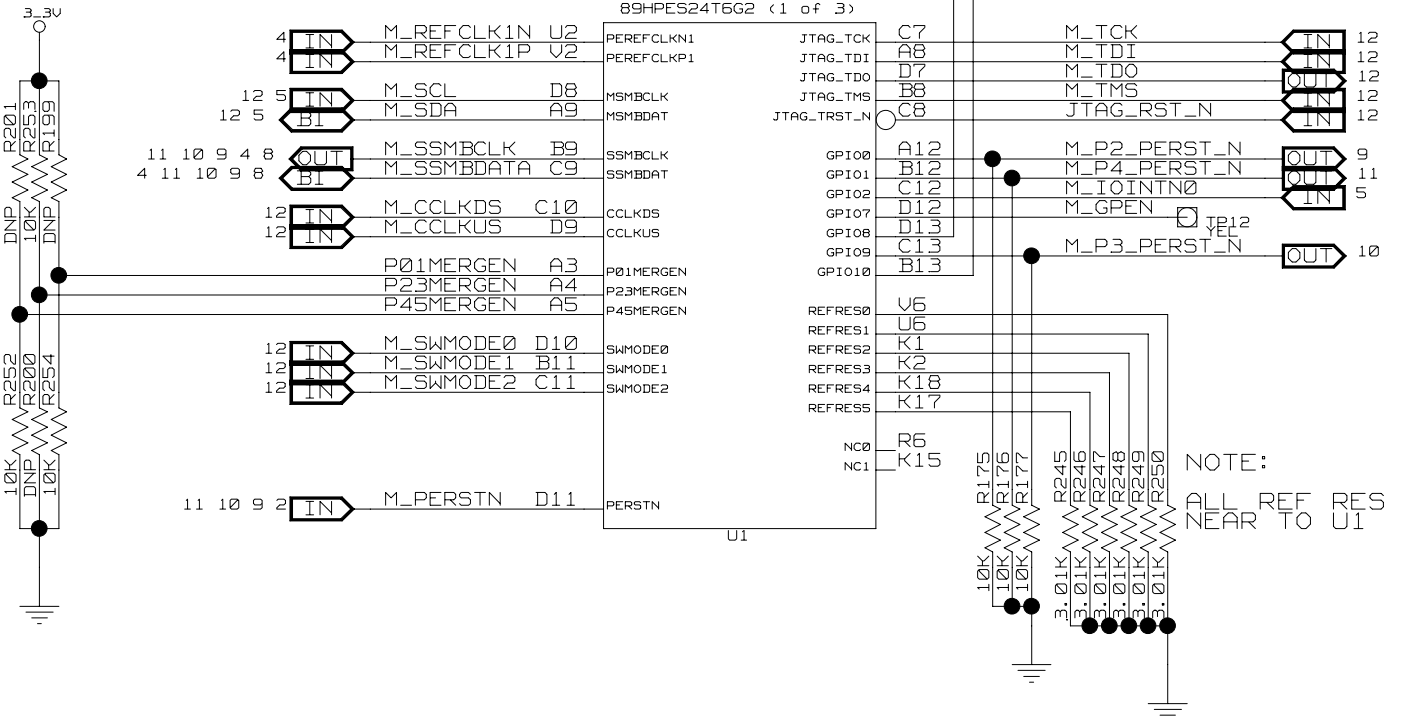
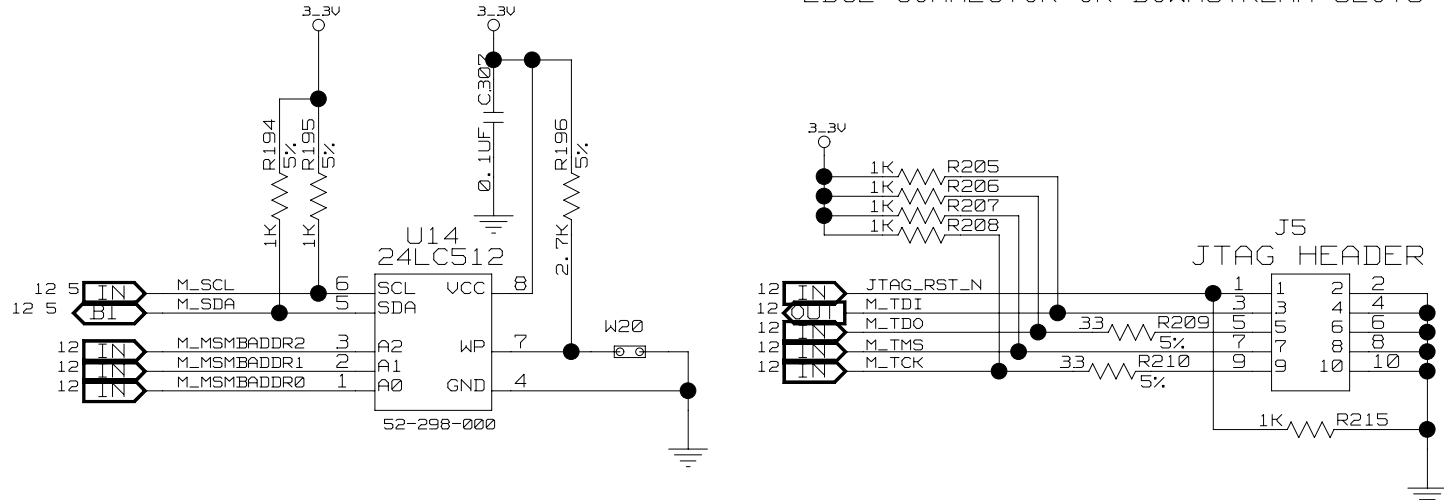

NOTE:
BOTH BIT7 AND BIT8 DEFAULT ARE "ON".



CONFIDENTIAL PROPERTY OF INTEGRATED DEVICE TECHNOLOGY, INC.
6024 SILVER CREEK VALLEY RD. SAN JOSE, CA 95138
COPYRIGHT (C) IDT2007

TITLE 89HPES24T6G2
89HPES24T6G2 - EEPROM, JTAG

SIZE	DRAWING NO.	FAB P/N	REV.
B	SCH-00145	18-656-000	1.0
AUTHOR		CHECKED BY	
M Shen / K Leung		D Huang	
Wed Jan 09 11:31:53 2008			SHEET 12 OF 13

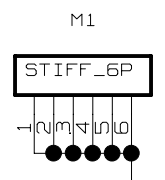
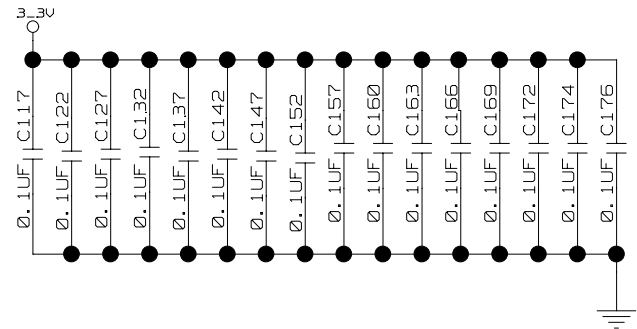
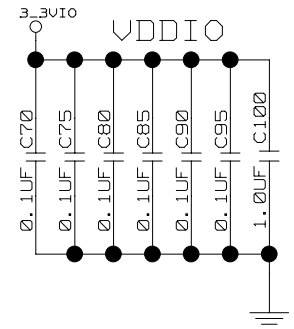
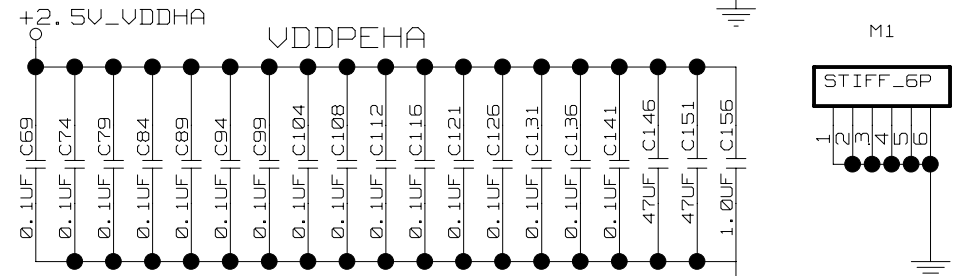
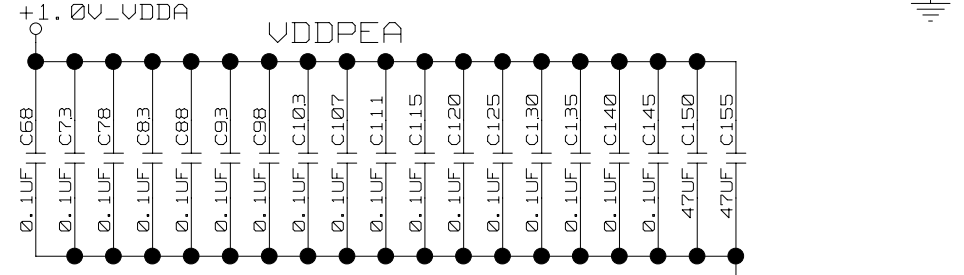
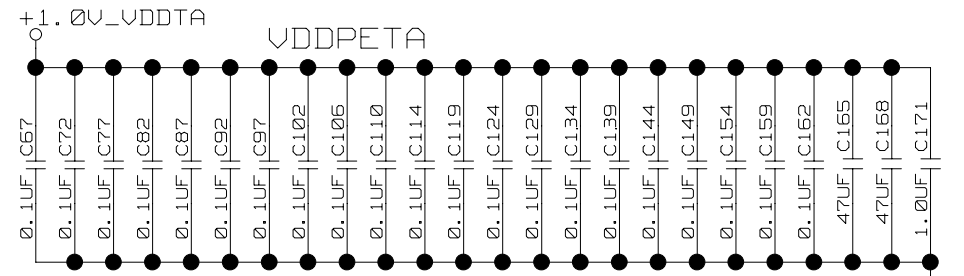
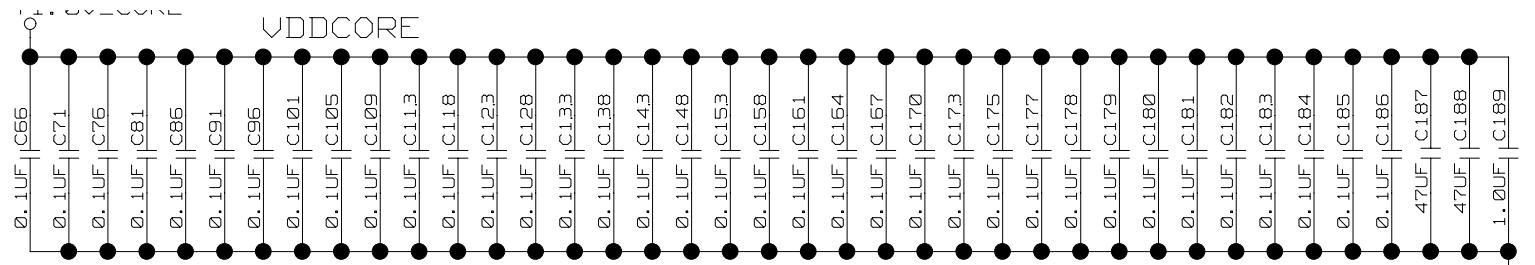
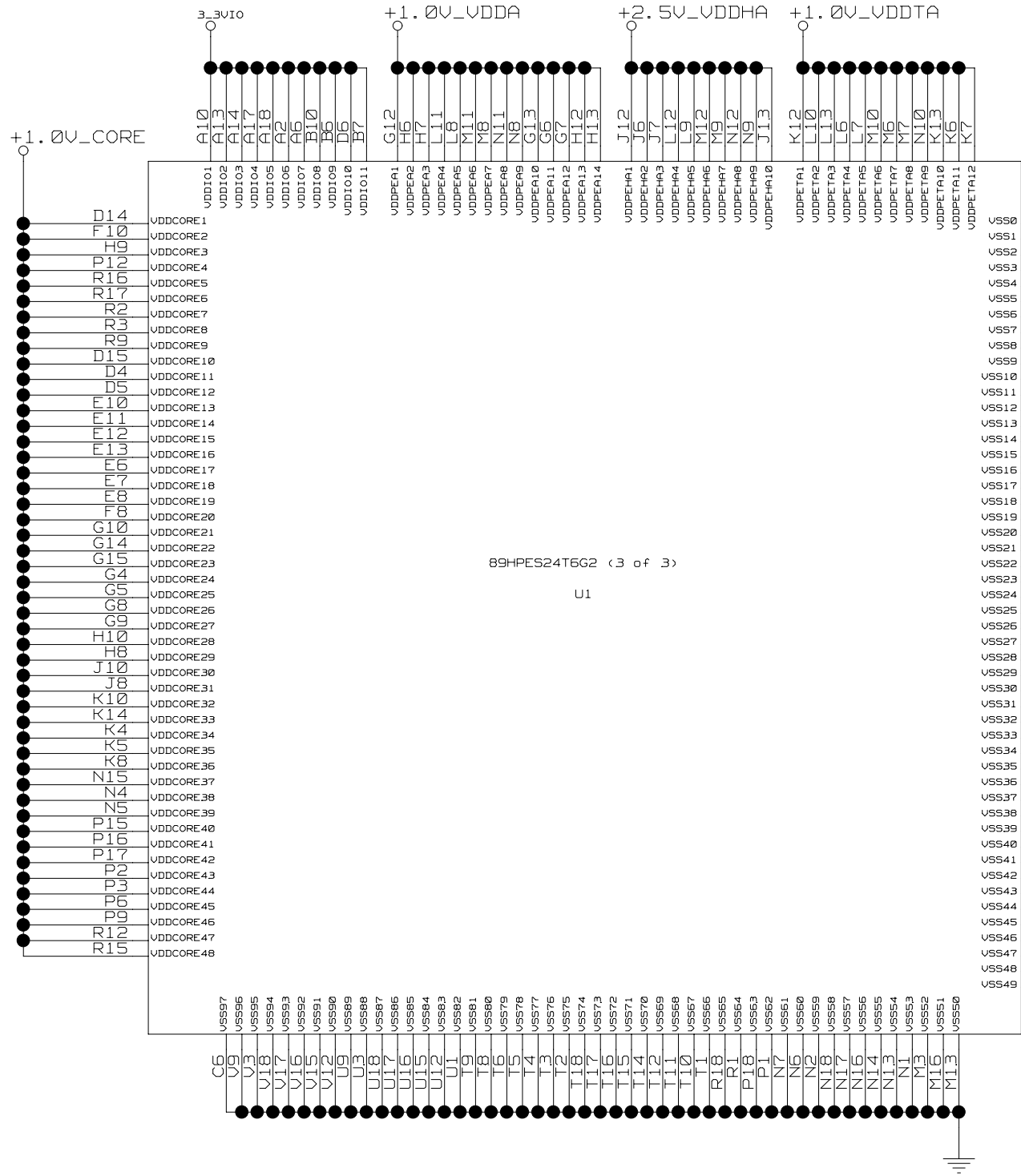

TITLE 89EBPES24T6G2			
89HPES24T6G2 - POWER			
SIZE B	DRAWING NO. SCH-00145	FAB P/N 18-656-000	REV. 1.0
AUTHOR M Shen / K Leung		CHECKED BY D Huang	
Wed Jan 09 11:31:58 2008			SHEET 13 OF 13

IMPORTANT NOTICE AND DISCLAIMER

RENESAS ELECTRONICS CORPORATION AND ITS SUBSIDIARIES (“RENESAS”) PROVIDES TECHNICAL SPECIFICATIONS AND RELIABILITY DATA (INCLUDING DATASHEETS), DESIGN RESOURCES (INCLUDING REFERENCE DESIGNS), APPLICATION OR OTHER DESIGN ADVICE, WEB TOOLS, SAFETY INFORMATION, AND OTHER RESOURCES “AS IS” AND WITH ALL FAULTS, AND DISCLAIMS ALL WARRANTIES, EXPRESS OR IMPLIED, INCLUDING, WITHOUT LIMITATION, ANY IMPLIED WARRANTIES OF MERCHANTABILITY, FITNESS FOR A PARTICULAR PURPOSE, OR NON-INFRINGEMENT OF THIRD PARTY INTELLECTUAL PROPERTY RIGHTS.

These resources are intended for developers skilled in the art designing with Renesas products. You are solely responsible for (1) selecting the appropriate products for your application, (2) designing, validating, and testing your application, and (3) ensuring your application meets applicable standards, and any other safety, security, or other requirements. These resources are subject to change without notice. Renesas grants you permission to use these resources only for development of an application that uses Renesas products. Other reproduction or use of these resources is strictly prohibited. No license is granted to any other Renesas intellectual property or to any third party intellectual property. Renesas disclaims responsibility for, and you will fully indemnify Renesas and its representatives against, any claims, damages, costs, losses, or liabilities arising out of your use of these resources. Renesas' products are provided only subject to Renesas' Terms and Conditions of Sale or other applicable terms agreed to in writing. No use of any Renesas resources expands or otherwise alters any applicable warranties or warranty disclaimers for these products.

(Disclaimer Rev.1.0 Mar 2020)

Corporate Headquarters

TOYOSU FORESIA, 3-2-24 Toyosu,
Koto-ku, Tokyo 135-0061, Japan
www.renesas.com

Contact Information

For further information on a product, technology, the most up-to-date version of a document, or your nearest sales office, please visit:
www.renesas.com/contact/

Trademarks

Renesas and the Renesas logo are trademarks of Renesas Electronics Corporation. All trademarks and registered trademarks are the property of their respective owners.