

16x9 G click

PID: MIKROE-2520

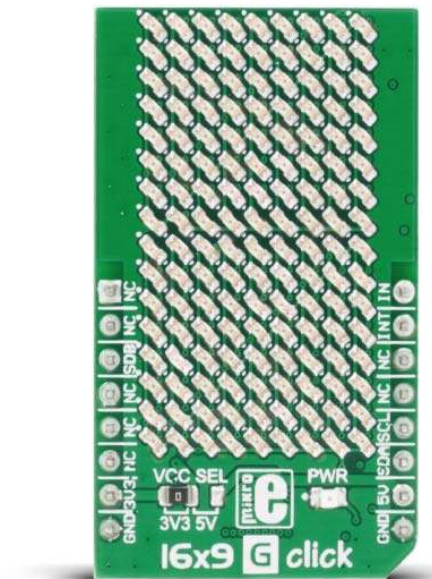

16x9 G click contains a **green LED matrix** and the IS31FL3731 audio modulated matrix LED driver. The dimension of the LED matrix is 16x9. Each LED can be controlled individually – both for on/off control and light intensity. The click is designed to run on either 3.3V or 5V power supply. It communicates with the target microcontroller over I2C interface and the following mikroBUS™ pins: PWM, INT, CS.

The IS31FL3731 matrix driver

The IS31FL3731 is a compact LED driver for **144 single LEDs**. The driver has three operating modes, Picture Mode, Auto Frame Play Mode and Audio Frame Play Mode:

Picture Mode — the driver can store up to 8 frames. In Picture Mode you can show one of these frames at a time.

Auto Frame Play Mode — In this mode you can automatically play the 8 frames in order.

Audio Frame Play Mode —You can play the 8 frames to the rhythm of the music of your choice. The displayed LED frames can be modulated with audio signal intensity. The driver plays the first frame when the value is the smallest and plays the eighth frame when the value is the biggest.

For more information about the different modes, see the LED driver datasheet.

Audio signal - The LED frames can be modulated with the intensity of the audio signal.

Light intensity - It is possible to set the intensity of each frame individually, and to use the intensity setting of frame 1 for all other frames.

Key features

- 16x9 LED matrix
- 144 single LEDs
- IS31FL3731 matrix LED driver
 - 8 frames memory for animations
 - Picture mode and animation mode
 - LED frames displayed can be modulated with audio signal intensity
 - LED light intensity can be modulated with audio signal intensity
 - Individual blink control
- I2C interface
- 3.3V or 5V power supply
-

SPECIFICATION

Product Type	LED Matrix
Applications	LED display for various hand-held devices, home appliances, IoT devices, etc.
On-board modules	IS31FL3731 matrix LED driver
Key Features	16x9 LED matrix, 144 single LEDs, 8 frames memory for animations, Individual blink control, Auto Frame Play Mode, Audio Frame Play Mode
Key Benefits	light intensity control, Audio Frame Play Mode
Interface	I2C
Power Supply	3.3V or 5V
Compatibility	mikroBUS
Click board size	M (42.9 x 25.4 mm)

Pinout diagram

This table shows how the pinout on **16x9 G click** corresponds to the pinout on the mikroBUS™ socket (the latter shown in the two middle columns).

Notes	Pin	 mikroBUS™				Pin	Notes
Not connected	NC	1	AN	PWM	16	IN	PWM Input
Not connected	NC	2	RST	INT	15	INT	Interrupt
Standby	SDB	3	CS	RX	14	NC	Not connected
Not connected	NC	4	SCK	TX	13	NC	Not connected
Not connected	NC	5	MISO	SCL	12	SCL	I2C clock
Not connected	NC	6	MOSI	SDA	11	SDA	I2C data
Power supply	+3.3V	7	3.3V	5V	10	+5V	Power supply
Ground	GND	8	GND	GND	9	GND	Ground

Jumper and Settings

This table shows the onboard jumpers and additional settings.

Designator	Name	Default Position	Default Option	Description
JP1	PWR.SEL.	Left	3V3	Power Supply Voltage Selection 3.3V/5V, left position 3.3V, right position 5V
JP2	ADDR SEL	Left	0	The last two bits of the I2C address

Programming

The Library provide access to the function registers of the driver, and basic graphic manipulation of each frame.

Code snippet

The code snippet shows how to draw one frame and display it.

```
01 void main()
02 {
03     system_init();
04
05     // Hardware power on.
06     click_16x9_shutdown_hw(false);
07     // Software shutdown mode.
08     click_16x9_shutdown_sw(true);
09
10     // Turn on all LED's in frame 1, and draw circle.
11     click_16x9_begin_frame(FRAME_1);
12     {
13         click_16x9_control_all(CTRL_LED, true);
14         click_16x9_fill_screen(0x00);
15         click_16x9_circle(x, y, radius, pwm);
16     }
17     click_16x9_end_frame();
18
19     // Display frame 1.
20     click_16x9_func_reg(REG_PICTURE_DISPLAY, 0);
21
22     // Software normal operation mode.
23     click_16x9_shutdown_sw(false);
24
25     while (1);
26 }
```