

# APPROVAL SHEET



\*Contents in this sheet are subject to change without prior notice.

## Features

1. Impedance  $75\Omega$  or  $50\Omega$ .
2. Excellent solderability.

## Applications

1. TV Tuner、STB and Mobile devices.

## Shape and Dimension

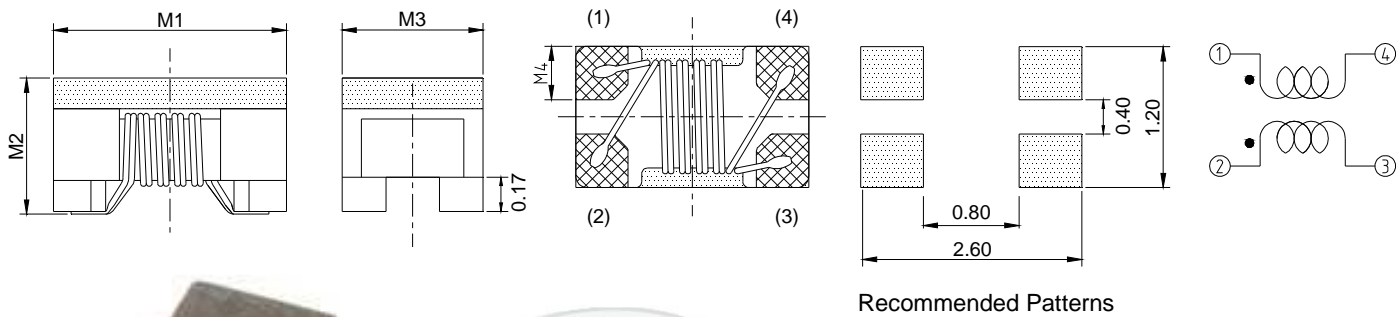

Unit: mm

SERIES	M1	M2	M3	M4
WTBL2012	$2.0\pm 0.2$	$1.20\pm 0.2$	$1.20\pm 0.2$	0.45(TYP.)

## Ordering Information

WT	BL	2012	Z0	U	001	P	B
<b>Product Code</b>	<b>Series</b>	<b>Dimensions</b>	<b>Series extension</b>	<b>Tolerance</b>	<b>Value</b>	<b>Packing Code</b>	
WT: Transformer /Balun /Common Mode Choke	Balun	2.0 * 1.2 mm	Z0	Undefined	Serial NO.	P=7" Reeled (Embossed tape)	B:STD

## Electrical Characteristics

Part Number	UB/B Impedance (ohm)	Insulation (m OHM) Min.	Withstand Voltage (DCV)	DCR (OHM) MAX.	Rated Voltage (DCV)	Rated Current (mA)	Frequency Range	Insertion Loss at Freq. Range (max.)
WTBL2012Z0U001PB	50/50	10	125	0.35	50	330	40MHz To 0.86GHz	2.5
WTBL2012Z0U002PB	75/75	10	125	0.35	50	330	50MHz To 1.2GHz	1.2
WTBL2012Z0U003PB	75/75	10	125	0.35	50	330	1.0GHz To 1.5GHz	1.4
WTBL2012Z0U004PB	75/75	10	125	0.35	50	330	50MHz To 1.2GHz	1.2
WTBL2012Z0U005PB	50/50	10	125	0.35	50	330	400MHz To 1.8GHz	2.2
WTBL2012Z0U006PB	75/75	10	125	0.50	50	330	400MHz To 1.8GHz	2.0
WTBL2012Z0U007PB	75/75	10	125	0.50	50	330	50MHz To 1.2GHz	1.2
WTBL2012Z0U008PB	75/75	10	125	0.35	50	330	400MHz To 1.5GHz	1.4
WTBL2012Z0U009PB	75/75	10	125	0.50	50	330	50MHz To 2.35GHz	2.0
WTBL2012Z0U010PB	75/75	10	125	0.50	50	330	250MHz To 2.35GHz	1.5

1. Insertion Loss Tested by AgilentE5071C
2. DCR Tested by Zentech502BC
3. Operating Temperature Range -40°C ~ +85°C \*MSL Level : 1

## TYPICAL RoHS REFLOW PROFILE

### Typical RoHS Reflow Profile

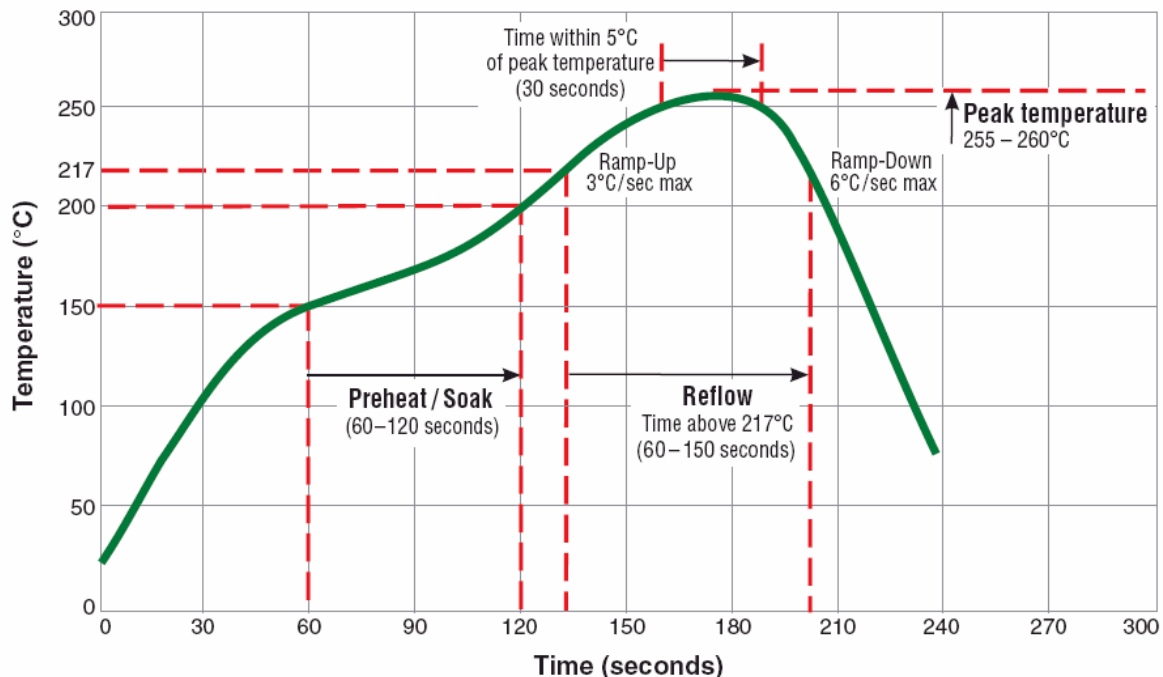

## RELIABILITY PERFORMANCE

### Reliability Experiment For Electrical

Test Item	Test Condition	Standard Source
Humidity Test	+40°C ± 2°C, humidity of 90% ± 5% (total 96 hours).	MIL-STD-202G Method 103B Test Condition B
High Temperature Test	1. Temperature: +125°C ± 2°C 2. Test time: 48 ± 2hrs	IEC 68-2 Test Condition B
Low Temperature Test	1. Temperature: -40°C ± 2°C 2. Test time: 48 ± 2hrs	IEC 68-2 Test Condition A
Thermal Shock	+125°C ± 5°C (30 minutes) ~ -40 ± 5°C (30 minutes), temperature switch time: 5 minutes (total 50 cycles).	MIL-STD-202G Method 107G Test Condition B-2
Life Test	+70°C ± 5°C (250Hours)	MIL-STD-202G Method 108A Test Condition B

### Reliability Experiment For Physical

Test Item	Test Condition	Standard Source
Vibration Test	10-55-10HZ, amplitude: 1.5mm, direction: X, Y, Z axes, each axis 2 hours (total 6 hours).	MIL-STD-202G Method 201A
Solder Heat Resistance Test	IR/convection reflow: Peak Temp 250 ± 5°C for 5Sec in air, Through 2 Cycle. Temperature Ramp: +1 ~ 4°C/sec; Above 183°C, must keep 90 s - 120 s	MIL-STD-202G Method 210F Test Condition (Reflow)
Solder Ability Test	Soak in 245 °C solder pot of 3Sec, PAD must have 95% above coverage.	J-STD-003B

### Tape & Reel Packaging Dimensions:

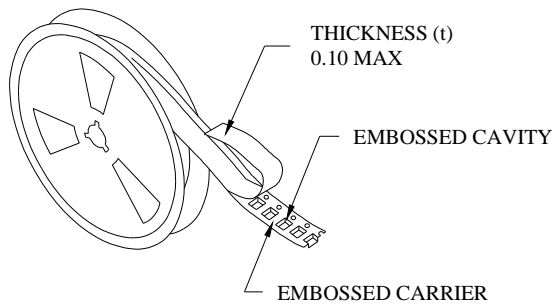

- THE FORCE FOR TEARING OFF COVER TAPE IS 10 TO 100 GRAMS IN THE ARROW DIRECTION.

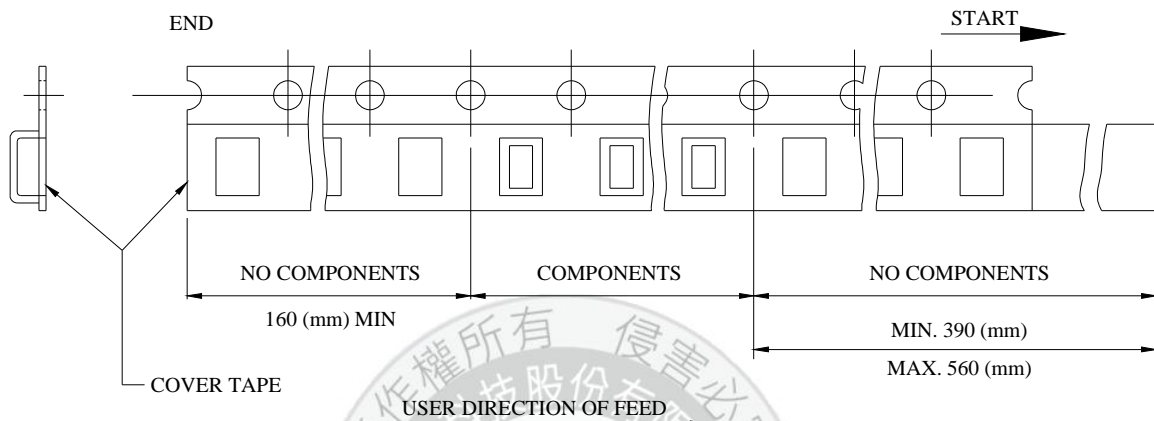
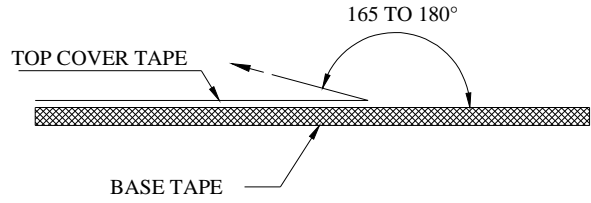

#### ■ CARRIER TAPE REELS (mm)

MATERIAL: PLASTIC

#### ■ DIMENSIONS OF CARRIER TAPE (mm)

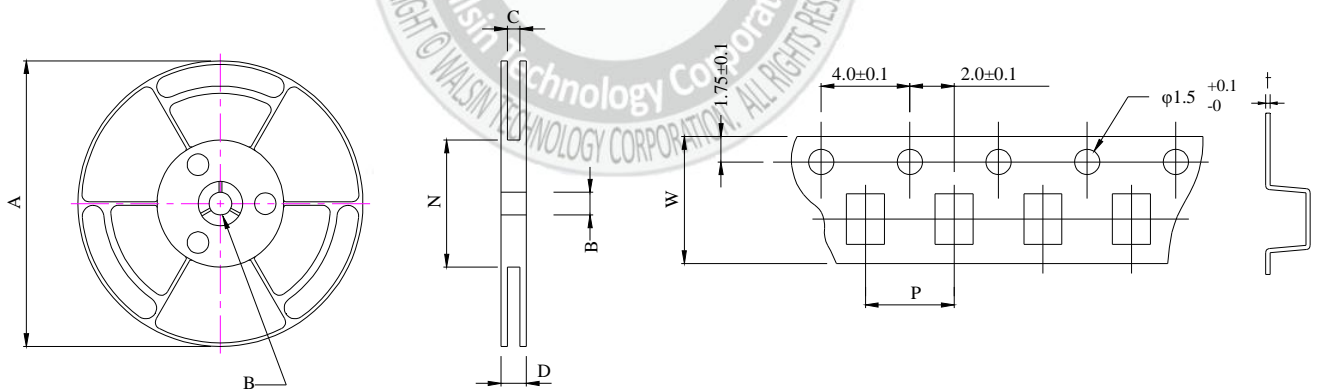

UNIT : mm

	A	B	C	D	N	P	W	t
DIM.	178	13.0	8.4	12.5	50	4.0	8.00	0.22
TOL.	±2.0	±0.8	+1.0-0	MAX	MIN	±0.10	±0.20	±0.05

Quantity per reel : 2K pcs