

DO NOT SCALE FROM THIS PRINT

TABLE 1 [F]		
ITEM	COMPONENT	-H
1	HEX NUT	SMA-NUT-001-F
2	LOCK WASHER	SMA-LWAS-001-F
3	GASKET	SMA-GKT-002
4	SUB ASSEMBLY	SUB-SMA-J-C-F-ST-SB3
5	PIN	SMA-PIN-006-H
6	INSULATOR	SMA-INS-017
7	CABLE BODY	SMA-J-C-F-ST-BH4-CBDY

GENDER
-J: JACK

TYPE
-C: CABLE

TERMINATION
-SR4: SEALED REVERSE POLARITY BULKHEAD (MH113)

ORIENTATION
-ST: STRAIGHT

PLATING SPECIFICATION [F]
-H: 30μ" GOLD CENTER CONTACT, 3μ" GOLD OUTER CONTACT (SEE TABLE 1)

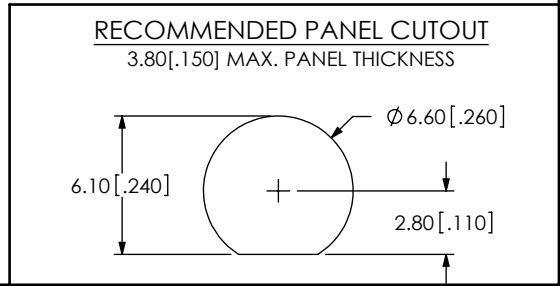
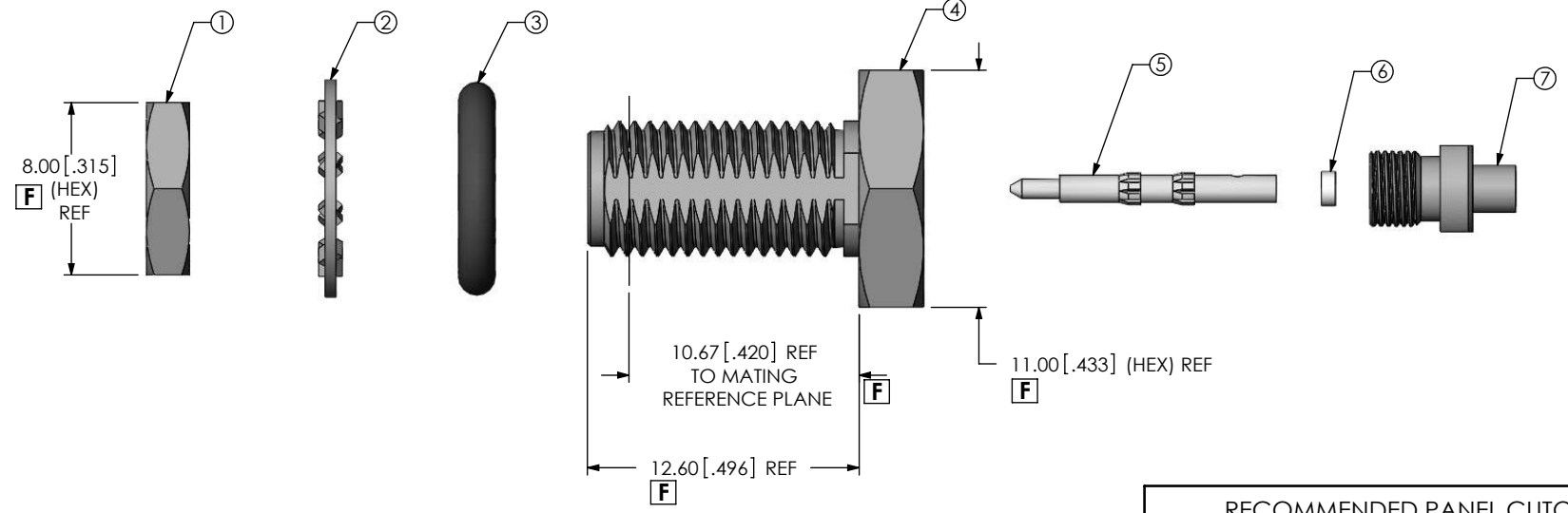

- NOTES: [F]
- ⊕ REPRESENTS A CRITICAL DIMENSION.
 - NOTE DELETED.
 - NOTE DELETED.
 - NOTE DELETED.
 - PRODUCT TO BE PACKAGED PER PACKAGING STANDARD CO-HD-WI-3040-M.
 - NOTE DELETED.
 - NOTE DELETED.
 - NOTE DELETED.

<p>UNLESS OTHERWISE SPECIFIED, DIMENSIONS ARE IN MILLIMETERS [INCHES]. TOLERANCES ARE:</p> <p>DECIMALS ANGLES [F]</p> <p>.X: ±0.3 [.01] 5°</p> <p>.XX: ±0.13 [.005]</p> <p>.XXX: ±0.051 [.0020]</p>	<p>PROPRIETARY NOTE</p> <p>THIS DOCUMENT CONTAINS INFORMATION CONFIDENTIAL AND PROPRIETARY TO SAMTEC, INC. AND SHALL NOT BE REPRODUCED OR TRANSFERRED TO OTHER DOCUMENTS OR DISCLOSED TO OTHERS OR USED FOR ANY PURPOSE OTHER THAN THAT WHICH IT WAS OBTAINED WITHOUT THE EXPRESSED WRITTEN CONSENT OF SAMTEC, INC.</p>	 <p>520 PARK EAST BLVD, NEW ALBANY, IN 47150 PHONE: 812-944-6733 FAX: 812-948-5047 e-Mail: info@SAMTEC.com code 55322</p>
<p>MATERIAL: DO NOT SCALE DRAWING SHEET SCALE: 1:0.333333</p> <p>SHELL, FERRULE, NUT, WASHER: BRASS CONTACT: BRASS DIELECTRIC: PTFE GASKET: SILICON</p>		<p>DESCRIPTION: SMA STR JACK S REV POLARITY BULKHEAD, MH113- 50 OHM</p> <p>DWG. NO. SMA-J-C-X-ST-SR4</p> <p>BY: R MUSSER 04/21/2009 SHEET 1 OF 2</p>

REVISION F

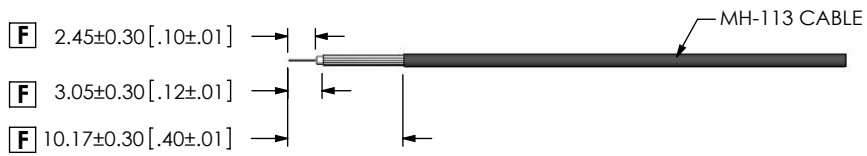

F IN PROCESS 1
STRIP AND TIN INNER
CONDUCTOR

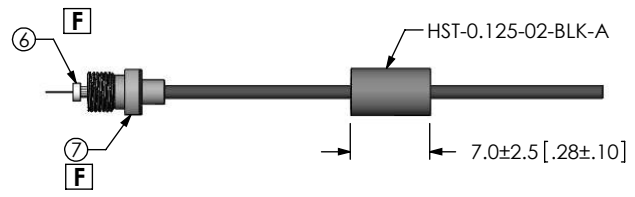
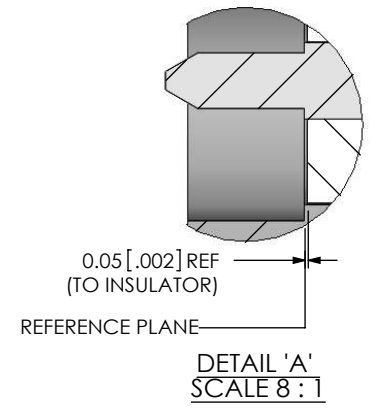

F IN PROCESS 2
ADD HEAT SHRINK TUBE,
REAR THREADED BODY,
AND INSULATOR

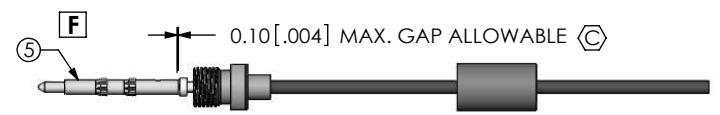

F IN PROCESS 3
SOLDER SIGNAL PIN AND
APPLY LOCTITE 680 TO THREADS

F

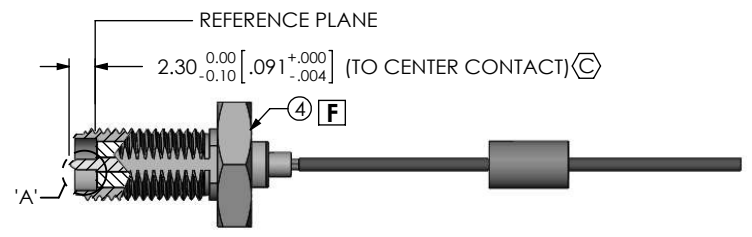

F IN PROCESS 4
ADD SUB ASSEMBLY
& TIGHTEN REAR-THREADED
BODY TO 10 IN-LBS

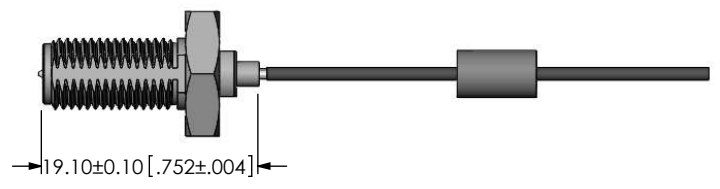

F IN PROCESS 5
SOLDER SHIELD

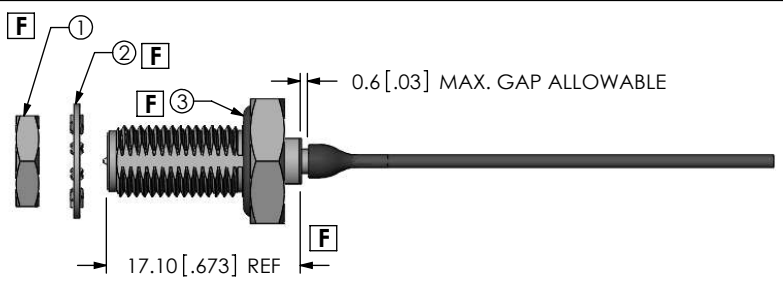

F IN PROCESS 6
APPLY HEAT SHRINK TUBING
& ADD GASKET

F:\DWG\MISC\MKTG\SMA-J-C-X-ST-SR4-MKT.SLDRW

PROPRIETARY NOTE
THIS DOCUMENT CONTAINS INFORMATION
CONFIDENTIAL AND PROPRIETARY TO
SAMTEC, INC. AND SHALL NOT BE REPRODUCED
OR TRANSFERRED TO OTHER DOCUMENTS OR
DISCLOSED TO OTHERS OR USED FOR ANY
PURPOSE OTHER THAN THAT WHICH IT WAS
OBTAINED WITHOUT THE EXPRESSED WRITTEN
CONSENT OF SAMTEC, INC.

DO NOT SCALE DRAWING
SHEET SCALE: 3:2



520 PARK EAST BLVD, NEW ALBANY, IN 47150
PHONE: 812-944-6733 FAX: 812-948-5047
e-Mail info@SAMTEC.com code 55322

DESCRIPTION:
SMA STR JACK S REV POLARITY BULKHEAD, MH113-50 OHM

DWG. NO. SMA-J-C-X-ST-SR4

BY: R MUSSER 04/21/2009 SHEET 2 OF 2