

THIS DRAWING IS UNPUBLISHED. RELEASED FOR PUBLICATION
 © COPYRIGHT BY TYCO ELECTRONICS CORPORATION. ALL RIGHTS RESERVED.

LOC	DIST	REVISIONS			
P	LTR	DESCRIPTION	DATE	DWN	APVD
CM	0				
	D	REVISED PER 0G3B-0237-05	9/21/05	SS	CJ

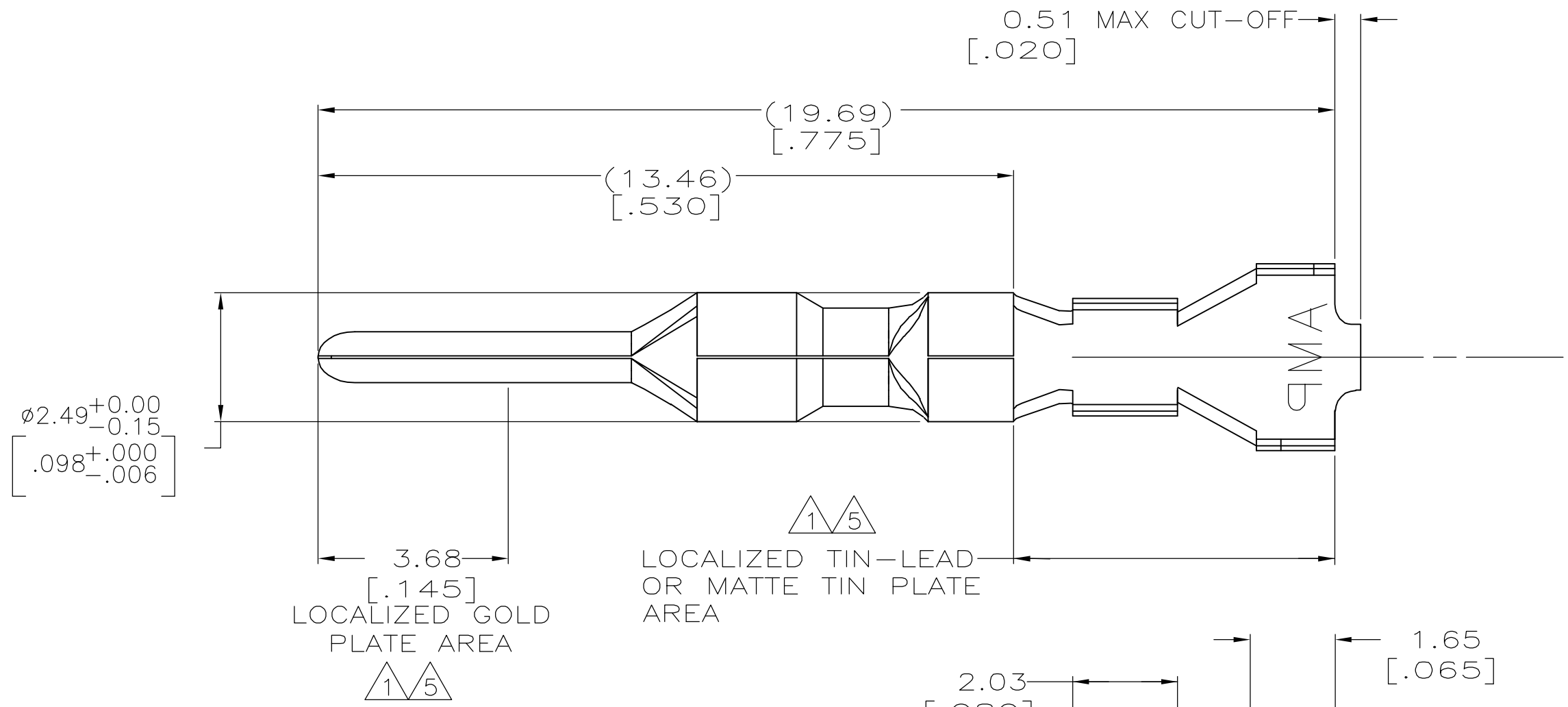

- 1 0.00076 [.000030] MIN GOLD PER AMP SPEC 112-162-3 IN LOCALIZED GOLD PLATE AREA AND 0.00254-0.00635 [.000100-.000250] BRIGHT TIN-LEAD PER AMP SPEC 112-26-1 IN LOCALIZED TIN-LEAD PLATE AREA OVER 0.00127 [.000050] MIN NICKEL PER AMP SPEC 112-25-2.
- 2. WIRE RANGE: 0.5-1.4MM² (20-16 AWG).
- 3. INSULATION RANGE: 2.01-3.20[.079-.126] DIA.
- 4. DIMENSIONS IN BRACKETS ARE IN INCHES.
- 5 0.00076 [.000030] MIN GOLD PER AMP SPEC 112-162-3 IN LOCALIZED GOLD PLATE AREA AND 0.00254-0.00635 [.000100-.000250] MATTE TIN PER AMP SPEC 112-16-3 IN LOCALIZED TIN PLATE AREA OVER 0.00127 [.000050] MIN NICKEL PER AMP SPEC 112-25-2.

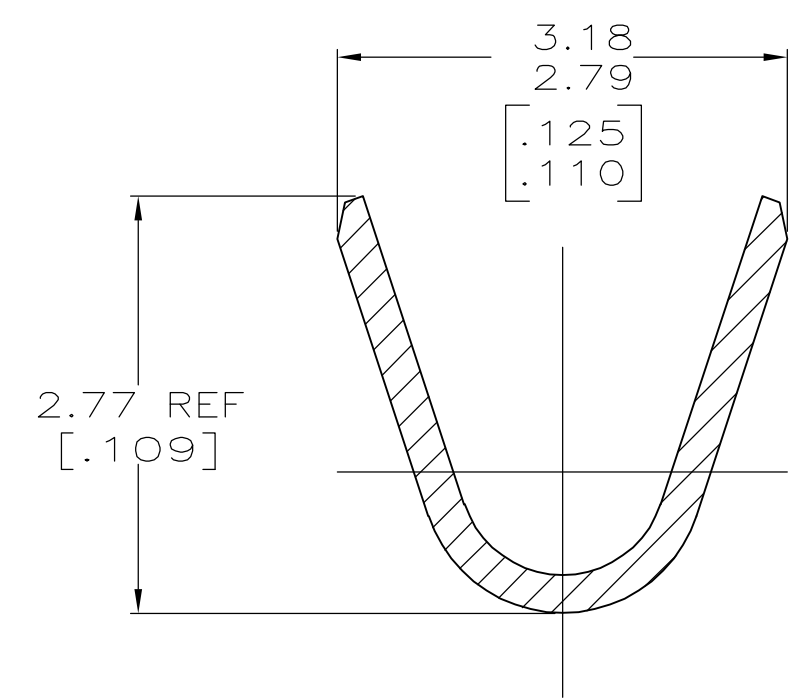
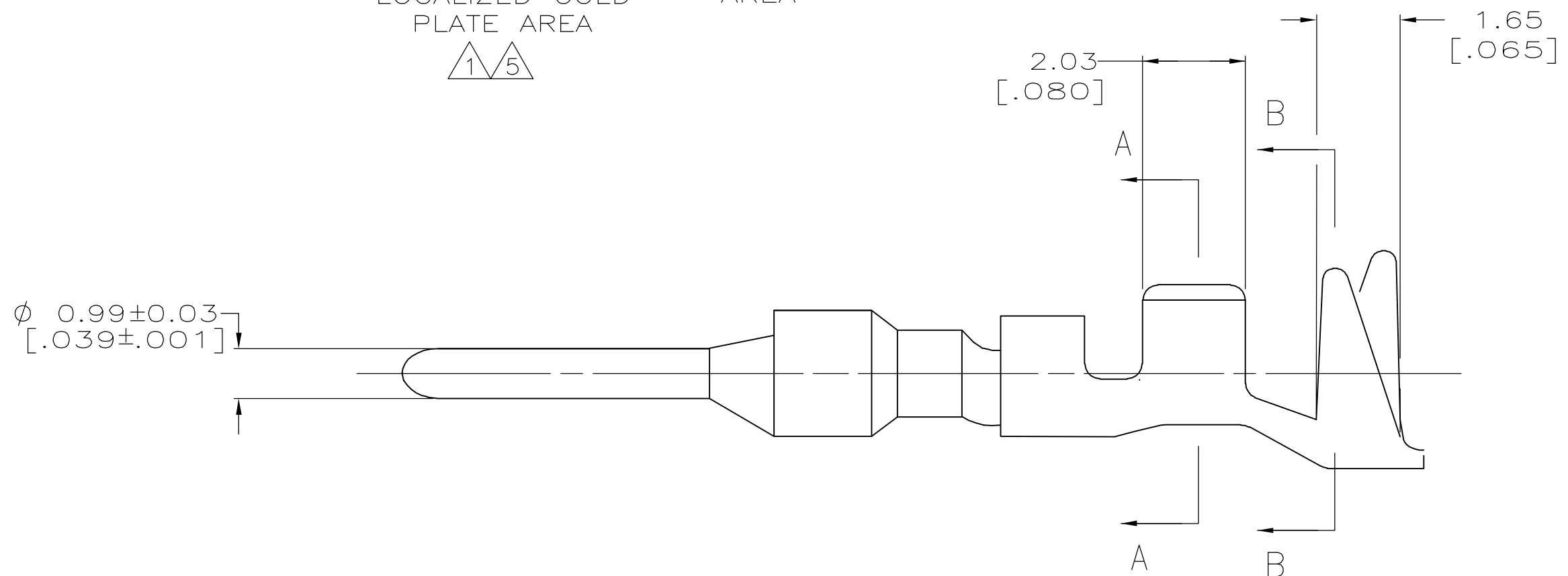

SECTION A-A
SCALE 20:1

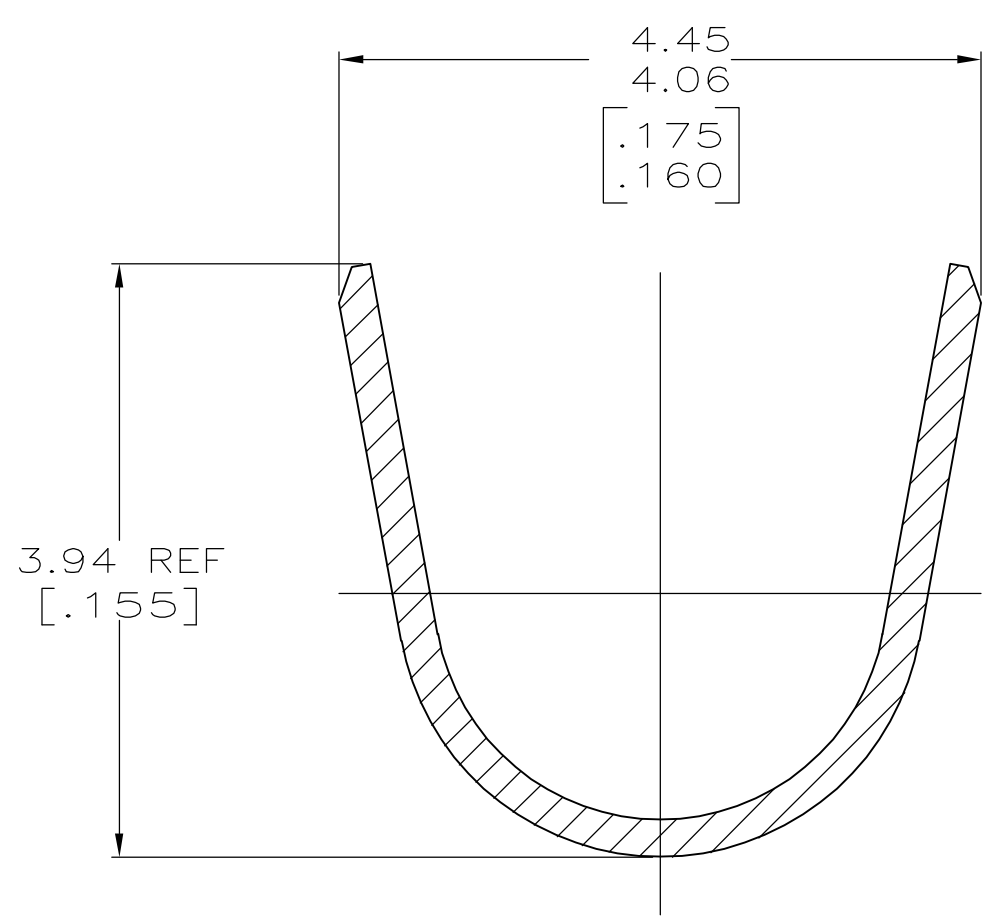

SECTION B-B
SCALE 20:1

5	0.25[.010] BRASS	1-794230-0
1	0.25[.010] BRASS	794230-3
PRE-TIN	0.25[.010] BRASS	794230-1
FINISH	MATERIAL	PART NUMBER

THIS DRAWING IS A CONTROLLED DOCUMENT.		DWN B. LEWIS 5-20-98	Tyco Electronics Corporation Harrisburg, PA 17105-3608	
DIMENSIONS: mm [INCHES]		CHK R. SWING 5-20-98	PIN, MINI UNIVERSAL MATE-N-LOK 2	
TOLERANCES UNLESS OTHERWISE SPECIFIED:		APVD -	RESTRICTED TO	
0 PLC ± -		PRODUCT SPEC -	-	
1 PLC ± -		APPLICATION SPEC -	SIZE A2	CAGE CODE 00779
2 PLC ± -		FINISH -	DRAWING NO C=794230	SCALE 10:1
3 PLC ± 0.15 [.006]		WEIGHT -	SHEET 1 of 1	REV D
4 PLC ± -		CUSTOMER DRAWING		
ANGLES ± -				
MATERIAL SEE TABLE				
FINISH SEE TABLE				

794230