

A
B
C
D
E
F

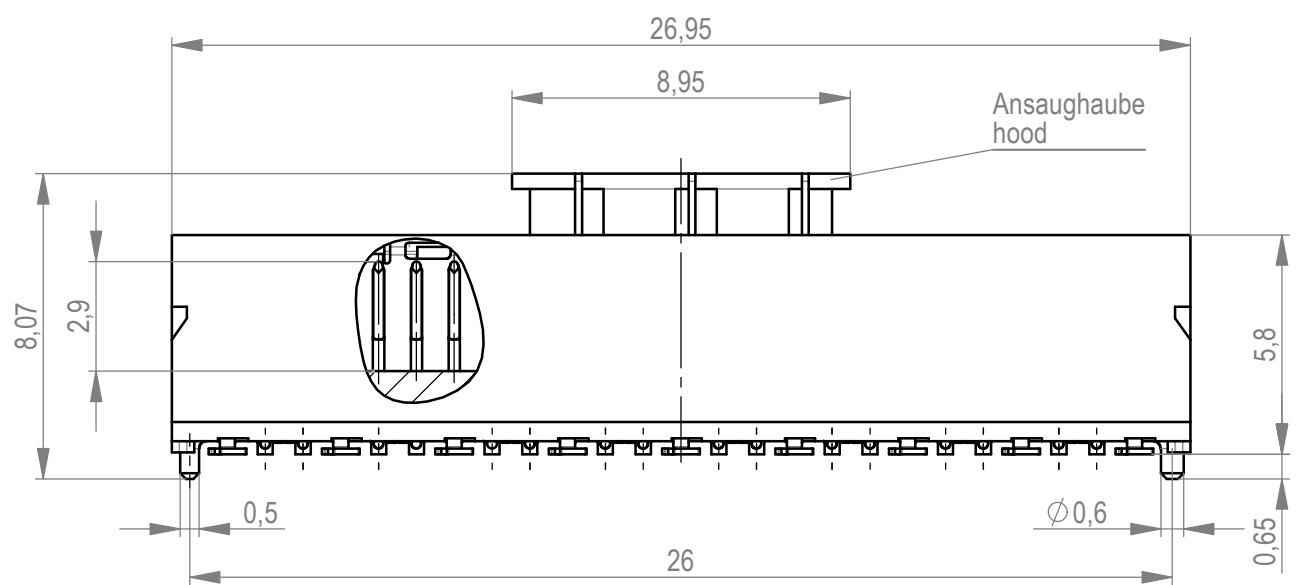

Ansaughaube
hood

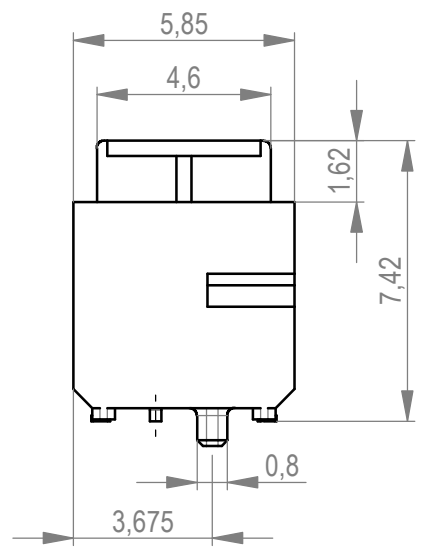

Verpackt im Gurt in Anlehnung an DIN IEC 60286-3
tape on reel packaging according to DIN IEC 60286-3
Verpackungseinheit: 400 Stück
packaging unit: 400 pcs

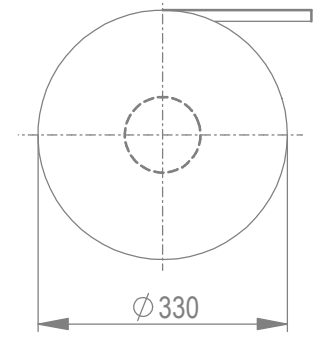

Abspulrichtung - reel off direction

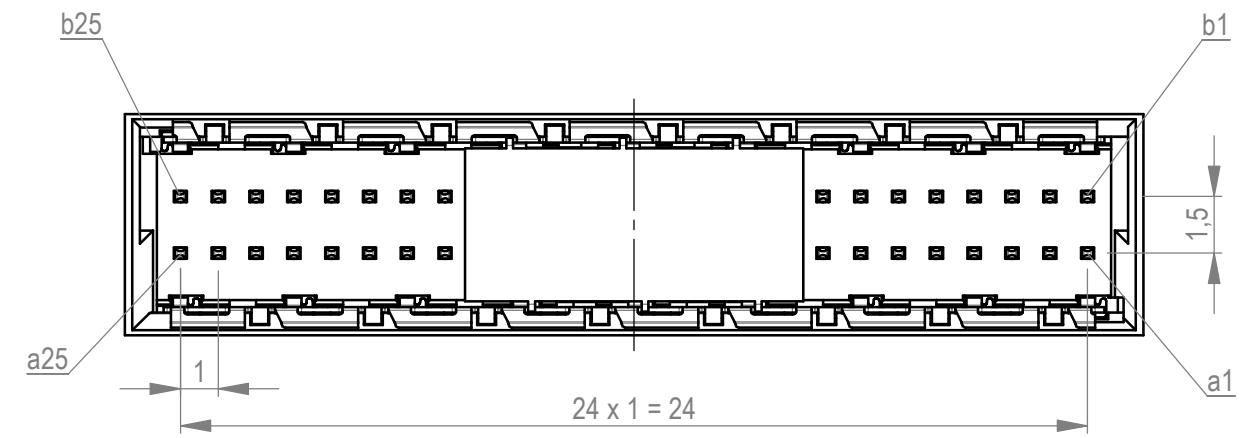

Leiterplatten-Layout Vorschlag / PCB-Layout proposal

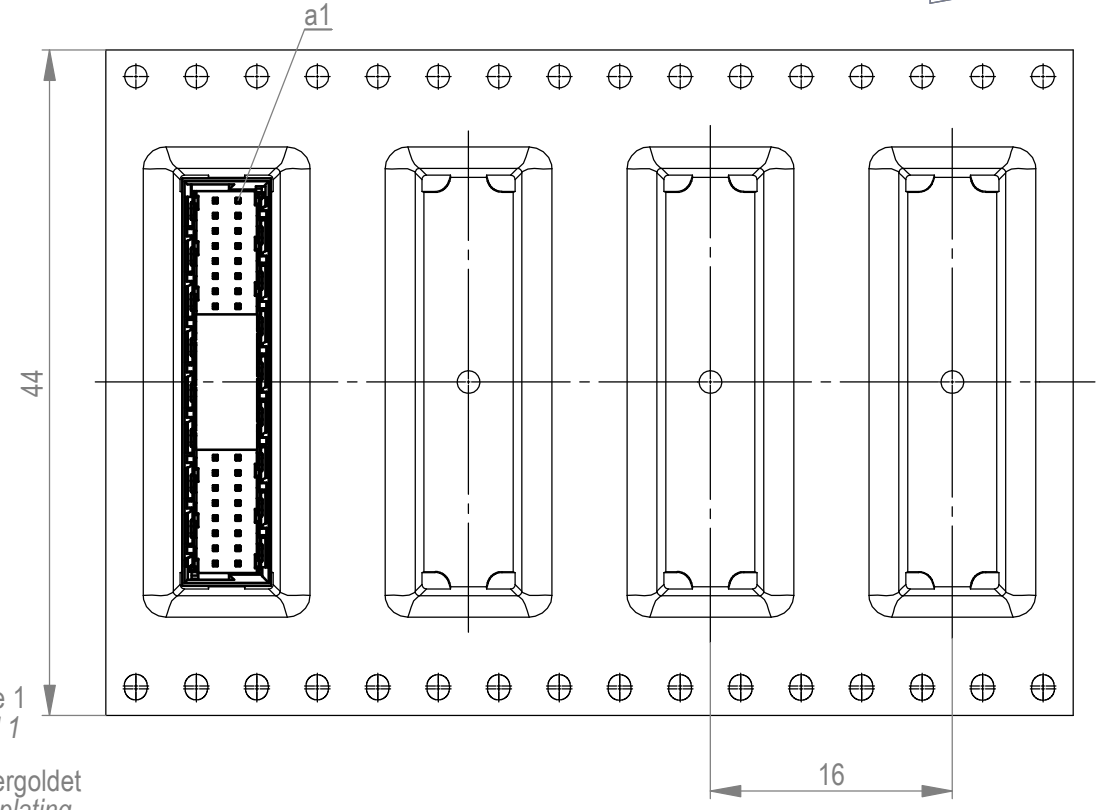

Anforderungsstufe 1
performance level 1

Kontaktbereich vergoldet
mating area gold plating

Anschlussbereich verzinkt 2-6 µm
terminal area 2-6 µm tin plating

Koplanarität der Anschlüsse ≤ 0,1 mm
coplanarity area of termination ≤ 0,1 mm

Zeichnung Spezifikation siehe ERNI Dokument 5.3.17
Drawing Specification according to ERNI Document 5.3.17

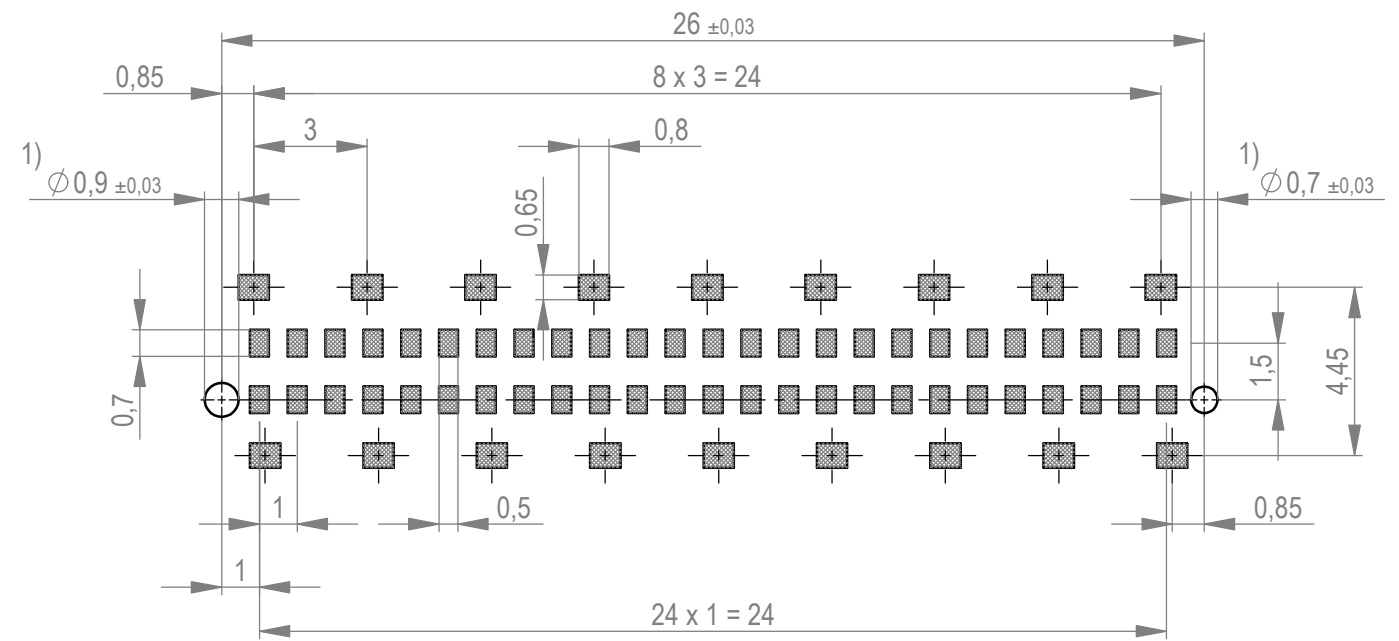

1) Durchmesser des Bohrers / drill tool

Weitergabe sowie Vervielfältigung dieses Dokuments, Verwertung und Mitteilung seines Inhalts sind verboten, soweit nicht ausdrücklich gestattet. Zuwiderhandlungen verpflichten zu Schadenersatz. Alle Rechte für den Fall der Patent-, Gebrauchsmuster- oder Geschmacksmustererhaltung vorbehalten. The reproduction, distribution and utilization of this document as well as the communication of its contents to others without express authorization is prohibited. Offenders will be held liable for the payment of damages. All rights reserved in the event of the grant of a patent, utility model or design.

Die deutsche Version dieser Zeichnung dient nur zur Erleichterung der Handhabung. Bei Abweichungen von dem englischen Original gilt das englische Original. The german version of this drawing has been offered for convenience only and may deviate from the english original. In case of any deviation the English version shall prevail.

Dimension no. - not assigned dimension no.:	Tolerances ISO 8015	All Dimensions in mm	Scale 5:1 Material
Customer drawing: All rights reserved. Only for Information. To ensure that this is the latest version of this drawing, please contact one of the ERNI companies before using.	Subject to modification without prior notice. Drawing will not be updated.		Male Straight 02mm SMT 50p Standard 2row 224557
k Index	13.08.2020 Date	ERNI International AG Zürichstrasse 72 8306 Brüttisellen - Zürich Switzerland	
			Class MSPEED