

# DCmind Brushless motor

## Data sheet

80 140 060

Series

80 140 TNI21

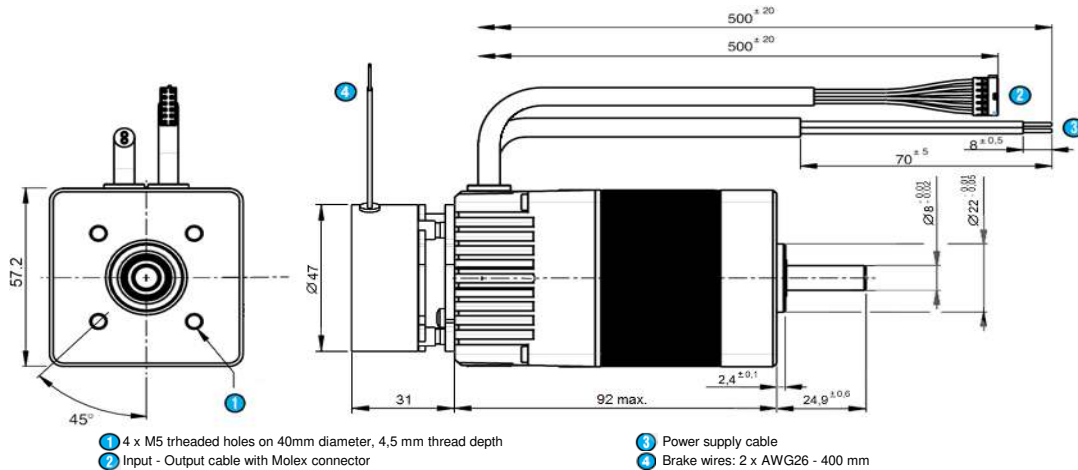

- ① 4 x M5 threaded holes on 40mm diameter, 4,5 mm thread depth  
 ② Input - Output cable with Molex connector

- ③ Power supply cable  
 ④ Brake wires: 2 x AWG26 - 400 mm

## General characteristics

Power supply		
Direct current voltage supply		* <sup>f</sup>
Nominal voltage range	Vdc	12 -> 32
Max. current	A	10

Motor characteristics (1)					
		12 Vdc	24 Vdc	32 Vdc	
<b>At no load</b>					
Max. output speed	rpm	2 900	4 000	4 000	
Current at the max output speed	A	0,34	0,29	0,27	
Standby current	A	0,08	0,09	0,09	+10%

<b>At nominal</b>					
Speed	rpm	1 900	4 000	4 000	+10%
Torque (2)	mNm	193	184	178	
Output power	W	38	77	75	+10%
Current	A	5,2	4,4	3,2	
Efficiency	%	62	74	73	

<b>At max. output power</b>					
Speed	rpm	1 600	3 050	4 000	
Torque	mNm	250	358	358	
Output power	W	42	114	150	+10%
Current	A	6,5	10,0	10,0	
Efficiency	%	53	48	47	

<b>At peak torque</b>					
Speed	rpm	930	3 050	4 000	
Torque	mNm	358	358	358	
Output power	W	35	114	150	
Current	A	10	10	10	+10%

<b>Others</b>		
Life (3)	h	20 000
Rotor inertia	gcm <sup>2</sup>	75
Thermal Resistance	°/W	3
Thermal time constant	mn	20
Rotor pole number		4
Cogging torque	mNm	11
Weight	kg	0,95
Noise level	dBA	40

## Connecting

Input - Output cable		With Molex connector ref: 43025-0800
Output cable, UL style 2464 80°C 300V - 8 wires AWG24		
Input: ON/OFF	1 - Green	
Input: Direction	2 - Yellow	
Input: Torque limit	3 - Blue	
Input: Speed	4 - Orange	
0V	5 - Black	
Output: Pulse	6 - Brown	
Output: Torque limit reached	7 - Purple	
Output: Direction	8 - Red	
Power supply cable		
Cable UL style 2517 105°C 300V - 2 wires AWG16 - 500 mm		
+ 12Vdc -> + 32 Vdc	Brown	
0V	Blue	

Drive		TNI21
Type		TNI21
Built-in drive		* <sup>f</sup>
Internal encoder		12 pulses per turn
<b>Control</b>		
Speed		PWM
Torque		PWM
4 quadrants - low braking		* <sup>f</sup>
4 quadrants with regenerative energy		
Type" Trapezoidal"		* <sup>f</sup>
<b>Security</b>		
Short-circuit of outputs		* <sup>f</sup>
Input inverted		* <sup>f</sup>
Low voltage	Vdc	< 10
Short high voltage	Vdc	> 36
Stop at max internal drive temperature (2)	°C	110
Drive temperature allowing to restart	°C	90

Generic parameters			
Output shaft with ball bearings			* <sup>f</sup>
Max. Radial force (12mm from front face)	N		40
Max. axial force(4)	N		20
Temperature range	CEI60068-2-1/2	°C	-30 -> +70
Storage temperature		°C	-40 -> +80
Dielectric	1min 2mA 50Hz CEI60335	Vdc	
Motor insulation	CEI60085	class	E
Salt spray	CEI60068-2-58	severity	48h
Degree of protection (output shaft not included)	CEI60529	IP	65M
<b>EMC</b>			
Electrostatic Discharge	CEI61000-4-2	level	3
Electrical fast transient / burst test	CEI61000-4-4	level	3
Surge test	CEI61000-4-5	level	1
Radiated emission	EN55022	class	B
<b>Approvals</b>			
ROHS	2002/95/CE		* <sup>f</sup>
EC			* <sup>f</sup>

Brake		Static
Type		Static
Power OFF brake		* <sup>f</sup>
Voltage supply	Vdc	24 +- 10%
Nominal holding torque	Nm	0,5
Input power	W	6,6

Notes	
Values without tolerances are average production values.	
Added informations are in "TNI21 manual and security" on <a href="http://www.crouzet.com">www.crouzet.com</a>	
Motor not protected in case of reversed power voltage	
(1) Cold motor, 20 ° C ambient temperature, full speed	
(2) Max torque for continuous operation at 20 ° C, decrease this value for higher ambient temperature	
(3) Continuously rated torque, zero radial and axial loads	
(4) Pinion or pulley fitting are done at the Crouzet factory, before final assembly.	

## Drive electrical datas

Max. product characteristics			
Parameters			
Max. voltage supply "Vcc"	Vdc		39
Max. current "Icc max"	A		12
Max. voltage on inputs "Vin max"	Vdc		39
Max. voltage on outputs "Vout max"	Vdc		39
Max. output current "Iout max"	mA		50
Running datas			
Parameters			
Voltage supply "Vcc"	Vdc	Min	Typical
			Max
Voltage supply "Vcc"	Vdc	10	12/24/32
Current "Icc"	A	-	6
Standby power "Wo"	W	-	2
Vitesse réglable de	rpm	120	-
Couple moteur réglable de	mNm	35	-
Couple de maintien réglable de	mNm	35	-

Input datas			
Parameters			
Impedance - Input 1, 2	kΩ	Min	Typical
			Max
Impedance - Input 3, 4	kΩ	-	57
			69
Low level - Input 1, 2	Vdc	0	-
High level - Input 1, 2	Vdc	4	-
Low level - Input 3, 4	Vdc	0	-
High level - Input 3, 4	Vdc	7,5	-
PWM frequency	Hz	100	-
			2000
Output datas			
Parameters			
Low level Outputs	Vdc	Min	Typical
			Max
Low level Outputs	Vdc	0	-
with "pull down resistor" = 4,7KΩ and Vcc = 24 V			0,2
High level Outputs	Vdc	Vcc - 0,5	-
with "pull down resistor" = 4,7KΩ and Vcc = 24 V			Vcc
= voltage supply added from eventual rejeptive voltage			

## Speed-torque and current-torque curves

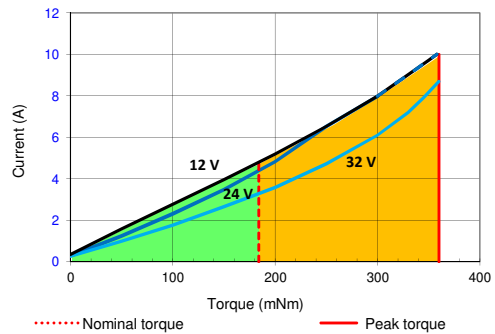
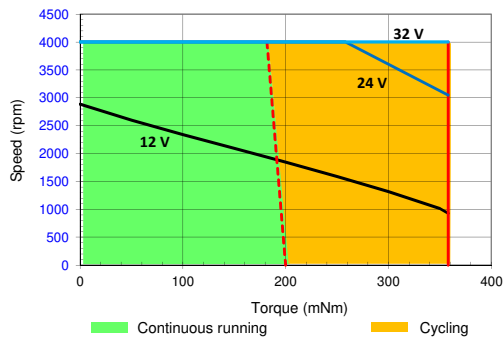

## Wiring

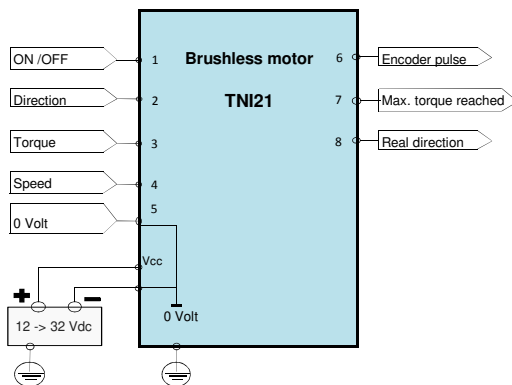

## Output equivalent circuit

### Outputs

PNP open collector output with internal current limitation (50mA)  
Add a pull down resistor

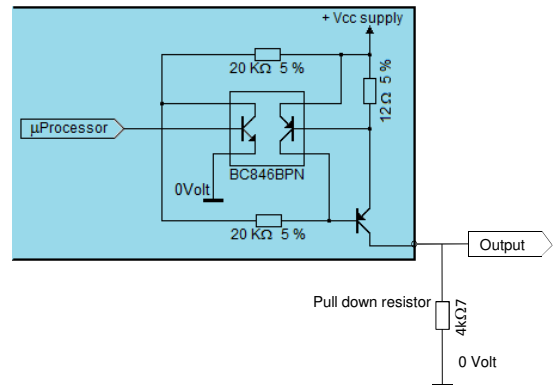

## Inputs: ON/OFF and Direction

### Inputs: ON/OFF and Direction

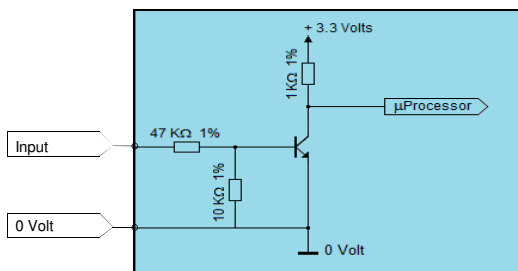

## Inputs: Torque and Speed

### Inputs: Torque and Speed

