



NTC thermistors for temperature measurement

Probe assemblies

Series/Type: M702/10K/J
Ordering code: B57702M0103J000
Date: 2021-10-15
Version: 1

Applications

- High-accuracy surface temperature measurement, e.g. on housings and pipes

Features

- High accuracy
- Easy to mount screw-on NTC sensor eg. M3 and M3.5 screws
- 2.5 mm lead spacing
- Good thermal coupling through metal tag
- Thermistor encapsulated in metal-tag case
- Cu-clad steel with tin plating, single-strand, $\varnothing 0.5$ mm (35 mm)
- UL approval (E69802)

Options

- Alternative lead lengths on request

Delivery mode

- Bulk

Dimensional drawing

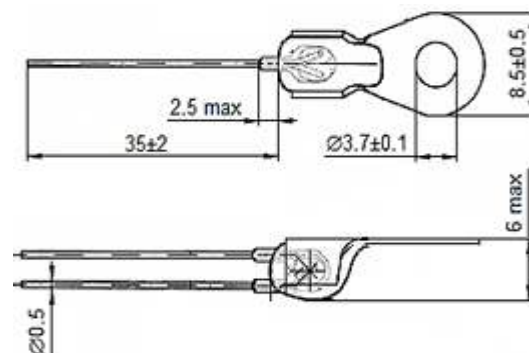

Dimensions in mm

General technical data

Climatic category	(IEC 60068-1)		40/125/21	
Maximum power	(at 25 °C)	P_{25}	200	mW
Resistance tolerance		$\Delta R_R/R_R$	±5	%
Rated temperature		T_R	25	°C
Dissipation factor	(in air)	δ_{th}	approx. 5.5 ¹⁾	mW/K
Thermal constant time	(on metal plate)	τ_a	approx. 7	s
Test voltage	(t = 1 s)	V_{test}	500	V AC

¹⁾ Depends on mounting situation.

Electrical specification and ordering code

R25 Ω	No. of R/T characteristic	$B_{25/100}$ K	Wire length in mm	Wire	Ordering code
10 k	4901	3950 ±3%	35 ±2	Cu-clad steel, tin plated	B57702M0103J000

NTC resistance temperature curve

R/T curve = 4901

 $B_{25/100} = 3950 \pm 3\% \text{ K}$
 $R_{25} = 10000 \pm 5\% \Omega$

Temp. [°C]	R_Nom [Ω]	R_Min [Ω]	R_Max [Ω]	ΔR [±%]
-40	316181	265179	367183	16.1
-35	230061	195406	264716	15.1
-30	169149	145400	192898	14.0
-25	125546	109152	141941	13.1
-20	94143	82738	105549	12.1
-15	71172	63195	79150	11.2
-10	54308	48695	59922	10.3
-5	41505	37563	45446	9.5
0	32014	29233	34795	8.7
5	25011	23033	26988	7.9
10	19691	18282	21100	7.2
15	15618	14614	16622	6.4
20	12474	11759	13188	5.7
25	10000	9500.0	10500	5.0
30	8080.0	7619.0	8541.0	5.7
35	6569.0	6153.0	6985.0	6.3
40	5372.0	4998.0	5746.0	7.0
45	4424.0	4090.0	4757.0	7.5
50	3661.0	3364.0	3958.0	8.1
55	3039.0	2775.0	3303.0	8.7
60	2536.0	2302.0	2770.0	9.2
65	2128.0	1921.0	2336.0	9.8
70	1794.0	1610.0	1978.0	10.3
75	1518.0	1355.0	1682.0	10.8
80	1290.0	1145.0	1435.0	11.2
85	1100.0	971.40	1229.0	11.7
90	941.80	827.20	1056.0	12.2
95	809.00	707.00	910.90	12.6
100	697.20	606.30	788.10	13.0
105	604.00	522.70	685.30	13.5
110	524.90	452.10	597.70	13.9
115	457.30	392.10	522.60	14.3
120	399.60	341.10	458.20	14.7
125	350.60	297.90	403.30	15.0

Reliability data

Test	Test conditions	$\Delta R_{25}/R_{25}$ (typical)	Remarks
Voltage proof test	The sensors placed in a vessel containing metallic balls (with total immersed head) at ambient temperature, max relative humidity 75%. The applied voltage is 500 V AC/1 s/0.5 mA		No flash over
Insulation test	The sensors placed in a vessel containing metallic balls of ≤ 1 mm diameter (with total immersed head). The applied voltage is 500 V DC.		Above 100 M Ω

Cautions and warnings

Storage

- Store thermistors only in original packaging. Do not open the package prior to storage.
- Storage conditions in original packaging: storage temperature $-25\text{ }^{\circ}\text{C}$... $+45\text{ }^{\circ}\text{C}$, relative humidity $\leq 75\%$ annual mean, $< 95\%$ maximum 30 days per annum, dew precipitation is inadmissible.
- Do not store thermistors where they are exposed to heat or direct sunlight. Otherwise, the packing material may be deformed or components may stick together, causing problems during mounting.
- Avoid contamination of thermistor surface during storage, handling and processing.
- Avoid storage of thermistors in harmful environments like corrosive gases (SO_x, Cl etc).
- Use the components as soon as possible after opening the factory seals, i.e. the polyvinyl-sealed packages.
- Solder thermistors within the time specified after shipment.
For leaded components this is 24 months.

Handling

- NTC thermistors must not be dropped. Chip-offs or any other damage must not be caused during handling of NTCs.
- Do not touch components with bare hands. Gloves are recommended.
- Avoid contamination of thermistor surface during handling.
- Washing processes may damage the product due to the possible static or cyclic mechanical loads (e.g. ultrasonic cleaning). They may cause cracks to develop on the product and its parts, which might lead to reduced reliability or lifetime.

Bending/Twisting

- Bending on wire is permitted at a minimum distance of twice the wire's diameter plus 4 mm from the component head or housing. When bending ensure the wire is mechanically relieved at the component head or housing. The bending radius should be at least eight times the wire's diameter.
- Twisting is prohibited as it may cause cracks and or reduce bonding between insulation and coating/potting material.

Soldering

- Use resin-type flux or non-activated flux.
- Insufficient preheating may cause ceramic cracks.
- Rapid cooling by dipping in solvent is not recommended.
- Complete removal of flux is recommended.

Mounting

- Ensure that no thermo-mechanical stress occurs due to production processes (curing or overmolding processes) when thermistors are sealed, potted or overmolded or during their subsequent operation. The maximum temperature of the thermistor must not be exceeded. Ensure that the materials used (sealing/potting compound and plastic material) are chemically neutral.
- Electrodes/contacts must not be scratched or damaged before/during/after the mounting process.
- Contacts and housing used for assembly with the thermistor must be clean before mounting.
- Ensure that adjacent materials are designed for operation at temperatures comparable to the surface temperature of the thermistor. Be sure that surrounding parts and materials can withstand the temperature.
- Avoid contamination of the thermistor surface during processing.
- The connections of sensors (e.g. cable end, wire end, plug terminal) may only be exposed to an environment with normal atmospheric conditions.
- Tensile forces on cables or leads must be avoided during mounting and operation.
- Bending or twisting of cables or leads directly on the thermistor body is not permissible.
- Avoid using chemical substances as mounting aids. It must be ensured that no water or other liquids enter the NTC thermistors (e.g. through plug terminals). In particular, water based substances (e.g. soap suds) must not be used as mounting aids for sensors.

Operation

- Use thermistors only within the specified operating temperature range.
- Use thermistors only within the specified power range.
- Environmental conditions must not harm the thermistors. Only use the thermistors under normal atmospheric conditions or within the specified conditions.
- Ensure that no significant thermo-mechanical stress occurs during operation due to the mounting situation. Fixtures must not overstress the sensor by an excessive mechanical preload.
- Contact of NTC thermistors with any liquids and solvents shall be prevented. It must be ensured that no water enters the NTC thermistors (e.g. through plug terminals). For measurement purposes (checking the specified resistance vs. temperature), the component must not be immersed in water but in suitable liquids (e.g. Galden).
- Avoid dewing and condensation unless thermistor is specified for these conditions.
- Bending or twisting of cables and/or wires is not permissible during operation of the sensor in the application.
- Be sure to provide an appropriate fail-safe function to prevent secondary product damage caused by malfunction.

This listing does not claim to be complete, but merely reflects the experience of TDK Electronics.

Display of ordering codes for TDK Electronics products

The ordering code for one and the same product can be represented differently in data sheets, data books, other publications, on the company website, or in order-related documents such as shipping notes, order confirmations and product labels. **The varying representations of the ordering codes are due to different processes employed and do not affect the specifications of the respective products.** Detailed information can be found on the Internet under www.tdk-electronics.tdk.com/orderingcodes.

Important notes

The following applies to all products named in this publication:

1. Some parts of this publication contain **statements about the suitability of our products for certain areas of application**. These statements are based on our knowledge of typical requirements that are often placed on our products in the areas of application concerned. We nevertheless expressly point out **that such statements cannot be regarded as binding statements about the suitability of our products for a particular customer application**. As a rule we are either unfamiliar with individual customer applications or less familiar with them than the customers themselves. For these reasons, it is always ultimately incumbent on the customer to check and decide whether a product with the properties described in the product specification is suitable for use in a particular customer application.
2. We also point out that **in individual cases, a malfunction of electronic components or failure before the end of their usual service life cannot be completely ruled out in the current state of the art, even if they are operated as specified**. In customer applications requiring a very high level of operational safety and especially in customer applications in which the malfunction or failure of an electronic component could endanger human life or health (e.g. in accident prevention or life-saving systems), it must therefore be ensured by means of suitable design of the customer application or other action taken by the customer (e.g. installation of protective circuitry or redundancy) that no injury or damage is sustained by third parties in the event of malfunction or failure of an electronic component.
3. **The warnings, cautions and product-specific notes must be observed.**
4. In order to satisfy certain technical requirements, **some of the products described in this publication may contain substances subject to restrictions in certain jurisdictions (e.g. because they are classed as hazardous)**. Useful information on this will be found in our Material Data Sheets on the Internet (www.tdk-electronics.tdk.com/material). Should you have any more detailed questions, please contact our sales offices.
5. We constantly strive to improve our products. Consequently, **the products described in this publication may change from time to time**. The same is true of the corresponding product specifications. Please check therefore to what extent product descriptions and specifications contained in this publication are still applicable before or when you place an order.

We also **reserve the right to discontinue production and delivery of products**. Consequently, we cannot guarantee that all products named in this publication will always be available. The aforementioned does not apply in the case of individual agreements deviating from the foregoing for customer-specific products.

6. Unless otherwise agreed in individual contracts, **all orders are subject to our General Terms and Conditions of Supply**.
7. **Our manufacturing sites serving the automotive business apply the IATF 16949 standard**. The IATF certifications confirm our compliance with requirements regarding the quality management system in the automotive industry. Referring to customer requirements and customer specific requirements ("CSR") TDK always has and will continue to have the policy of respecting individual agreements. Even if IATF 16949 may appear to support the acceptance of unilateral requirements, we hereby like to emphasize that **only requirements mutually agreed upon can and will be implemented in our Quality Management System**. For clarification purposes we like to point out that obligations from IATF 16949 shall only become legally binding if individually agreed upon.

Important notes

8. The trade names EPCOS, CarXield, CeraCharge, CeraDiode, CeraLink, CeraPad, CeraPlas, CSMP, CTVS, DeltaCap, DigiSiMic, ExoCore, FilterCap, FormFit, LeaXield, MiniBlue, MiniCell, MKD, MKK, ModCap, MotorCap, PCC, PhaseCap, PhaseCube, PhaseMod, PhiCap, PowerHap, PQSine, PQvar, SIFERRIT, SIFI, SIKOREL, SilverCap, SIMDAD, SiMic, SIMID, SineFormer, SIOV, ThermoFuse, WindCap, XieldCap are **trademarks registered or pending** in Europe and in other countries. Further information will be found on the Internet at www.tdk-electronics.tdk.com/trademarks.

Release 2020-06