

# FDC1004Q 4-Channel Capacitance-to-Digital Converter for Capacitive Sensing Solutions

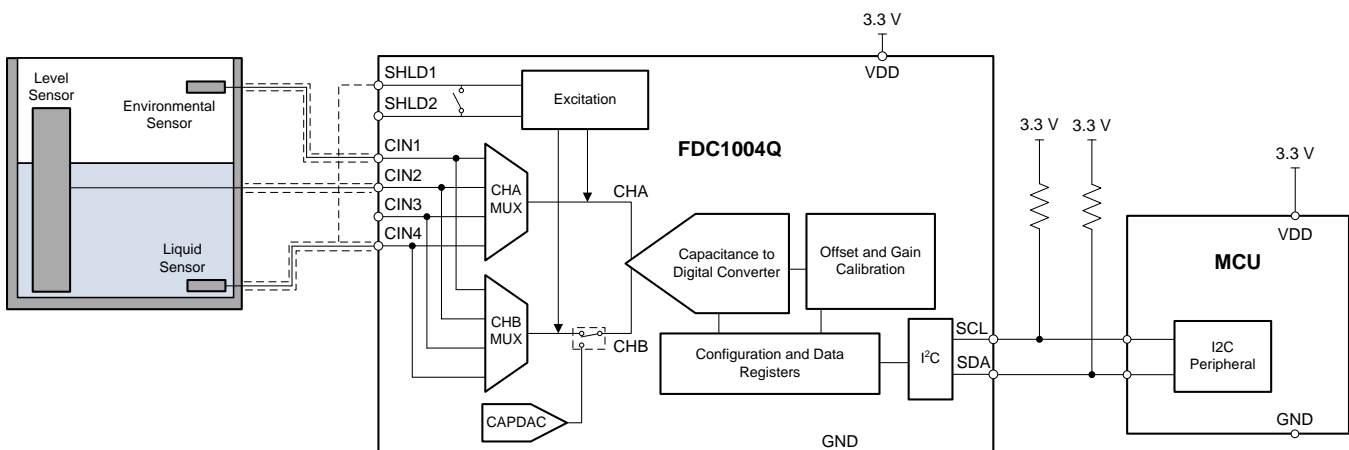
## 1 Features

- Qualified for Automotive Applications
- AEC-Q100 Qualified With the Following Results
  - Device Temperature Grade 1: -40°C to 125°C Ambient Operating Temperature Range
  - Device HBM ESD Classification Level 2
  - Device CDM ESD Classification Level C5
- Input Range:  $\pm 15$  pF
- Measurement Resolution: 0.5 fF
- Maximum Offset Capacitance: 100 pF
- Programmable Output Rates: 100/200/400 S/s
- Maximum Shield Load: 400 pF
- Supply Voltage: 3.3 V
- Temp Range: -40° to 125°C
- Current Consumption:
  - Active: 750  $\mu$ A
  - Standby: 29  $\mu$ A
- Interface: I<sup>2</sup>C
- Number of Channels: 4

## 2 Applications

- Proximity Sensor
- Gesture Recognition
- Automotive Door / Kick Sensors
- Automotive Rain Sensor
- Remote and Direct Liquid Level Sensor
- High-resolution Metal Profiling
- Rain / Fog / Ice / Snow Sensor
- Material Size Detection

## 4 Typical Application



## 3 Description

Capacitive sensing with grounded capacitor sensors is a very low-power, low-cost, high-resolution contactless sensing technique that can be applied to a variety of applications ranging from proximity sensing and gesture recognition to material analysis and remote liquid level sensing. The sensor in a capacitive sensing system is any metal or conductor, allowing for low cost and highly flexible system design.

The FDC1004Q is a high-resolution, AEC-Q100 qualified, 4-channel capacitance-to-digital converter for implementing capacitive sensing solutions. Each channel has a full scale range of  $\pm 15$  pF and can handle a sensor offset capacitance of up to 100 pF, which can be either programmed internally or can be an external capacitor for tracking environmental changes over time and temperature. The large offset capacitance capability allows for the use of remote sensors.

The FDC1004Q also includes shield drivers for sensor shields, which can reduce EMI interference and help focus the sensing direction of a capacitive sensor. The small footprint of the FDC1004Q allows for use in space-constrained applications. The FDC1004Q is available in a 10-pin VSSOP package, which allows for optical inspection in production, and features an I<sup>2</sup>C interface for interfacing to an MCU.

### Device Information<sup>(1)</sup>

PART NUMBER	PACKAGE	BODY SIZE (NOM)
FDC1004Q	VSSOP (DGS)	3.0 mm x 3.0 mm

(1) See the orderable addendum at the end of the datasheet for orderable part numbers.



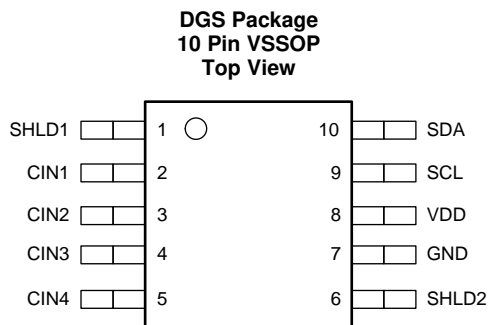
## Table of Contents

<b>1 Features</b> .....	<b>1</b>	8.4 Device Functional Modes .....	<b>10</b>
<b>2 Applications</b> .....	<b>1</b>	8.5 Programming .....	<b>12</b>
<b>3 Description</b> .....	<b>1</b>	8.6 Register Maps .....	<b>15</b>
<b>4 Typical Application</b> .....	<b>1</b>	<b>9 Applications and Implementation</b> .....	<b>19</b>
<b>5 Revision History</b> .....	<b>2</b>	9.1 Application Information .....	<b>19</b>
<b>6 Pin Configuration and Functions</b> .....	<b>3</b>	9.2 Typical Application .....	<b>20</b>
<b>7 Specifications</b> .....	<b>4</b>	9.3 Do's and Don'ts .....	<b>22</b>
7.1 Absolute Maximum Ratings .....	<b>4</b>	9.4 Initialization Set Up .....	<b>22</b>
7.2 ESD Ratings .....	<b>4</b>	<b>10 Power Supply Recommendations</b> .....	<b>22</b>
7.3 Recommended Operating Conditions .....	<b>4</b>	<b>11 Layout</b> .....	<b>22</b>
7.4 Thermal Information .....	<b>4</b>	11.1 Layout Guidelines .....	<b>22</b>
7.5 Electrical Characteristics .....	<b>5</b>	11.2 Layout Example .....	<b>22</b>
7.6 I <sup>2</sup> C Interface Voltage Level .....	<b>5</b>	<b>12 Device and Documentation Support</b> .....	<b>23</b>
7.7 I <sup>2</sup> C Interface Timing .....	<b>6</b>	12.1 Documentation Support .....	<b>23</b>
7.8 Typical Characteristics .....	<b>7</b>	12.2 Trademarks .....	<b>23</b>
<b>8 Detailed Description</b> .....	<b>9</b>	12.3 Electrostatic Discharge Caution .....	<b>23</b>
8.1 Overview .....	<b>9</b>	12.4 Glossary .....	<b>23</b>
8.2 Functional Block Diagram .....	<b>9</b>	<b>13 Mechanical, Packaging, and Orderable Information</b> .....	<b>23</b>
8.3 Feature Description .....	<b>9</b>		

## 5 Revision History

DATE	REVISION	NOTES
April 2015	*	Initial release.

## 6 Pin Configuration and Functions



### Pin Functions

PIN		TYPE <sup>(1)</sup>	DESCRIPTION
NAME	NO.		
SHLD1	1	A	Capacitive Input Active AC Shielding.
CIN1	2	A	Capacitive Input. The measured capacitance is connected between the CIN1 pin and GND. If not used, this pin should be left as an open circuit.
CIN2	3	A	Capacitive Input. The measured capacitance is connected between the CIN2 pin and GND. If not used, this pin should be left as an open circuit.
CIN3	4	A	Capacitive Input. The measured capacitance is connected between the CIN3 pin and GND. If not used, this pin should be left as an open circuit.
CIN4	5	A	Capacitive Input. The measured capacitance is connected between the CIN4 pin and GND. If not used, this pin should be left as an open circuit.
SHLD2	6	A	Capacitive Input Active AC Shielding.
GND	7	G	Ground
VDD	8	P	Power Supply Voltage. This pin should be decoupled to GND, using a low impedance capacitor, for example in combination with a 1- $\mu$ F tantalum and a 0.1- $\mu$ F multilayer ceramic.
SCL	9	I	Serial Interface Clock Input. Connects to the master clock line. Requires pull-up resistor if not already provided elsewhere in the system.
SDA	10	I/O	Serial Interface Bidirectional Data. Connects to the master data line. Requires a pull-up resistor if not provided elsewhere in the system.

(1) P=Power, G=Ground, I=Input, O=Output, A=Analog, I/O=Bi-Directional Input/Output

## 7 Specifications

### 7.1 Absolute Maximum Ratings<sup>(1)</sup>

		MIN	MAX	UNIT
Input voltage	VDD	-0.3	6	V
	SCL, SDA	-0.3	6	V
	at any other pin	-0.3	VDD+0.3	V
Input current	at any pin		3	mA
Junction temperature <sup>(2)</sup>			150	°C
Storage Temperature	T <sub>STG</sub>	-65	150	°C

- (1) Stresses beyond those listed under *Absolute Maximum Ratings* may cause permanent damage to the device. These are stress ratings only, which do not imply functional operation of the device at these or any other conditions beyond those indicated under *Recommended Operating Conditions*. Exposure to absolute-maximum-rated conditions for extended periods may affect device reliability.
- (2) The maximum power dissipation is a function of  $T_{J(MAX)}$ ,  $R_{\theta JA}$ , and the ambient temperature,  $T_A$ . The maximum allowable power dissipation at any ambient temperature is  $P_{DMAX} = (T_{J(MAX)} - T_A) / R_{\theta JA}$ . All numbers apply for packages soldered directly onto a PC board.

### 7.2 ESD Ratings

			VALUE	UNIT
V <sub>(ESD)</sub>	Electrostatic discharge	Human-body model (HBM), per AEC Q100-002 <sup>(1)</sup>	±2000	V
		Charged-device model (CDM), per AEC Q100-011	±750	

- (1) AEC Q100-002 indicates that HBM stressing shall be in accordance with the ANSI/ESDA/JEDEC JS-001 specification.

### 7.3 Recommended Operating Conditions

Over operating temperature range (unless otherwise noted)

	MIN	NOM	MAX	UNIT
Supply voltage (VDD-GND)	3	3.3	3.6	V
Temperature	-40		125	°C

### 7.4 Thermal Information

THERMAL METRIC <sup>(1)</sup>		FDC1004Q	UNIT
		VSSOP (DGS)	
		10 PINS	
R <sub>θJA</sub>	Junction-to-ambient thermal resistance	46.8	°C/W
R <sub>θJC</sub>	Junction-to-case(top) thermal resistance	48.7	°C/W
R <sub>θJB</sub>	Junction-to-board thermal resistance	70.6	°C/W

- (1) For more information about traditional and new thermal metrics, see the *IC Package Thermal Metrics* application report, [SPRA953](#).

## 7.5 Electrical Characteristics<sup>(1)</sup>

Over recommended operating temperature range,  $V_{DD} = 3.3\text{ V}$ , for  $T_A = 25^\circ\text{C}$  (unless otherwise noted).

PARAMETER		TEST CONDITION	MIN <sup>(2)</sup>	TYP <sup>(3)</sup>	MAX <sup>(2)</sup>	UNIT
<b>POWER SUPPLY</b>						
$I_{DD}$	Supply current	Conversion mode; Digital input to VDD or GND		750	950	$\mu\text{A}$
		Standby; Digital input to VDD or GND		29	70	$\mu\text{A}$
<b>CAPACITIVE INPUT</b>						
ICR	Input conversion range			$\pm 15$		pF
$C_{OMAX}$	Max input offset capacitance	per channel, Series resistance at $C_{INn} n=1,4 = 0\ \Omega$		100		pF
RES	Effective resolution <sup>(4)</sup>	Sample rate = 100S/s <sup>(5)</sup>		16		bit
EON	Output noise	Sample rate = 100S/s <sup>(5)</sup>		33.2		aF/ $\sqrt{\text{Hz}}$
ERR	Absolute error	after offset calibration		$\pm 6$		fF
$TcC_{OFF}$	Offset deviation over temperature	$-40^\circ\text{C} < T < 125^\circ\text{C}$		46		fF
$G_{ERR}$	Gain error			0.2%		
tcG	Gain drift vs. temperature	$-40^\circ\text{C} < T < 125^\circ\text{C}$		-37.5		ppm/ $^\circ\text{C}$
PSRR	DC power supply rejection	$3\text{ V} < V_{DD} < 3.6\text{ V}$ , single-ended mode (channel vs GND)		13.6		fF/V
<b>CAPDAC</b>						
$FR_{CAPDAC}$	Full-scale range			96.9		pF
$TcCOFF_{CAPDAC}$	Offset drift vs. temperature	$-40^\circ\text{C} < T < 125^\circ\text{C}$		30		fF
<b>EXCITATION</b>						
$f$	Frequency			25		kHz
$V_{AC}$	AC voltage across capacitance			2.4		V <sub>pp</sub>
$V_{DC}$	Average DC voltage across capacitance			1.2		V
<b>SHIELD</b>						
DRV	Driver capability	$f = 25\text{ kHz}$ , SHLDn to GND, n = 1,2			400	pF

- (1) Electrical Characteristics Table values apply only for factory testing conditions at the temperature indicated. Factory testing conditions result in very limited self-heating of the device such that  $T_J = T_A$ . No guarantee of parametric performance is indicated in the electrical tables under conditions of internal self-heating where  $T_J > T_A$ . Absolute Maximum Ratings indicate junction temperature limits beyond which the device may be permanently degraded, either mechanically or electrically.
- (2) Limits are ensured by testing, design, or statistical analysis at 25Degree C. Limits over the operating temperature range are ensured through correlations using statistical quality control (SQC) method.
- (3) Typical values represent the most likely parametric norm as determined at the time of characterization. Actual typical values may vary over time and will also depend on the application and configuration. The typical values are not tested and are not guaranteed on shipped production material.
- (4) Effective resolution is the ratio of converter full scale range to RMS measurement noise.
- (5) No external capacitance connected.

## 7.6 I<sup>2</sup>C Interface Voltage Level

Over recommended operating free-air temperature range,  $V_{DD} = 3.3\text{ V}$ , for  $T_A = T_J = 25^\circ\text{C}$  (unless otherwise noted).

PARAMETER	TEST CONDITIONS	MIN	TYP	MAX	UNIT
$V_{IH}$	Input high voltage	$0.7 \cdot V_{DD}$			V
$V_{IL}$	Input low voltage			$0.3 \cdot V_{DD}$	V
$V_{OL}$	Output low voltage	Sink current 3 mA		0.4	V
HYS	Hysteresis <sup>(1)</sup>	$0.1 \cdot V_{DD}$			V

- (1) This parameter is specified by design and/or characterization and is not tested in production.

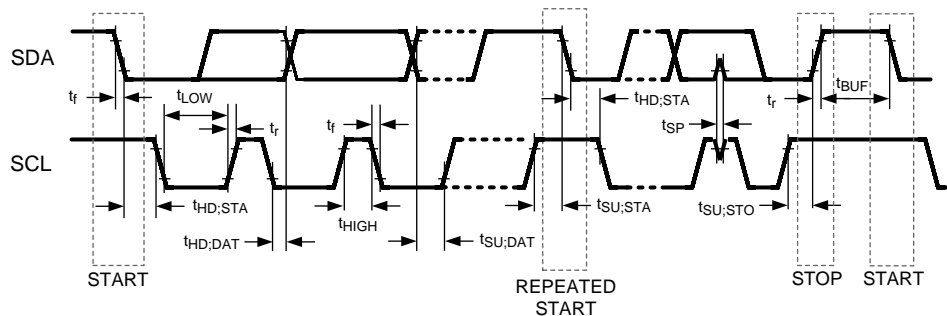
## 7.7 I<sup>2</sup>C Interface Timing

Over recommended operating free-air temperature range,  $V_{DD} = 3.3\text{ V}$ , for  $T_A = T_J = 25^\circ\text{C}$  (unless otherwise noted).

PARAMETER	TEST CONDITIONS	MIN	TYP	MAX	UNIT
$f_{SCL}$	Clock frequency <sup>(1)</sup>	10		400	kHz
$t_{LOW}$	Clock low time <sup>(1)</sup>	1.3			$\mu\text{s}$
$t_{HIGH}$	Clock high time <sup>(1)</sup>	0.6			$\mu\text{s}$
$t_{HD;STA}$	Hold time (repeated) START condition <sup>(1)</sup>	After this period, the first clock pulse is generated		0.6	$\mu\text{s}$
$t_{SU;STA}$	Set-up time for a repeated START condition <sup>(1)</sup>	0.6			$\mu\text{s}$
$t_{HD;DAT}$	Data hold time <sup>(1)(2)</sup>	0			ns
$t_{SU;DAT}$	Data setup time <sup>(1)</sup>	100			ns
$t_f$	SDA fall time <sup>(1)</sup>	$I_L \leq 3\text{mA}; CL \leq 400\text{pF}$		300	ns
$t_{SU;STO}$	Set-up time for STOP condition <sup>(1)</sup>	0.6			$\mu\text{s}$
$t_{BUF}$	Bus free time between a STOP and START condition <sup>(1)</sup>	1.3			$\mu\text{s}$
$t_{VD;DAT}$	Data valid time <sup>(1)</sup>			0.9	ns
$t_{VD;ACK}$	Data valid acknowledge time <sup>(1)</sup>			0.9	ns
$t_{SP}$	Pulse width of spikes that must be suppressed by the input filter <sup>(1)</sup>			50	ns

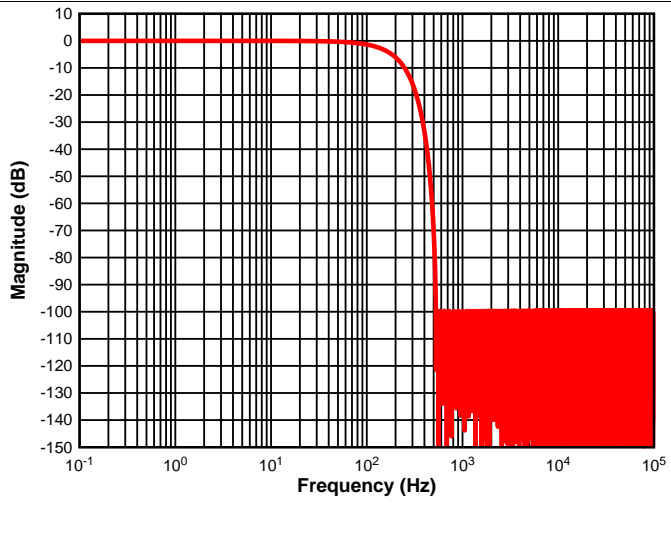
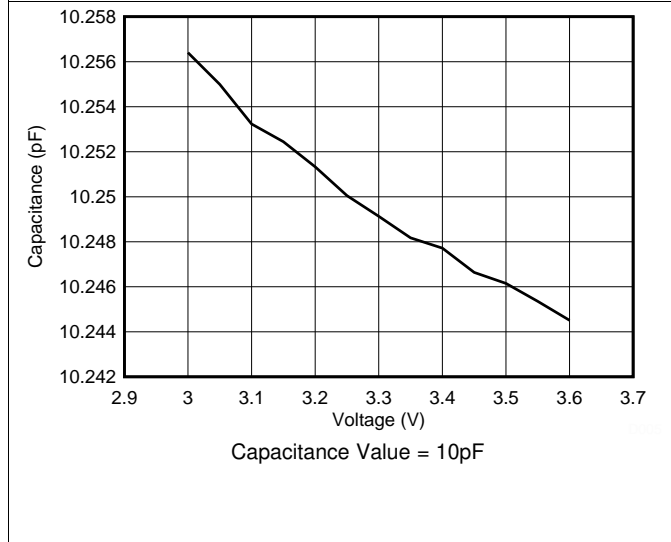
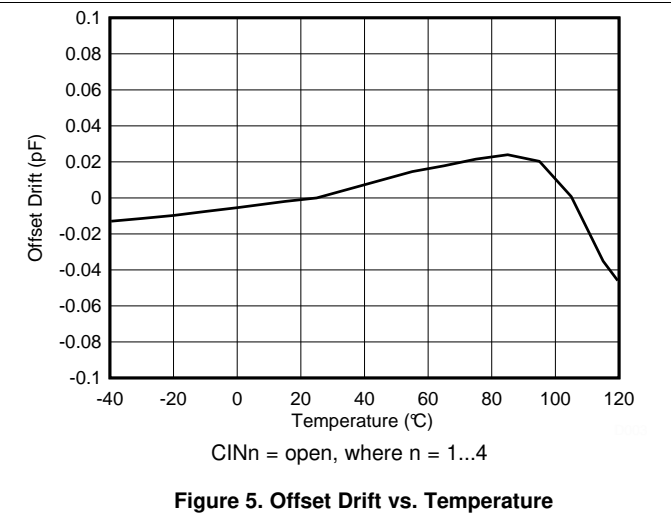
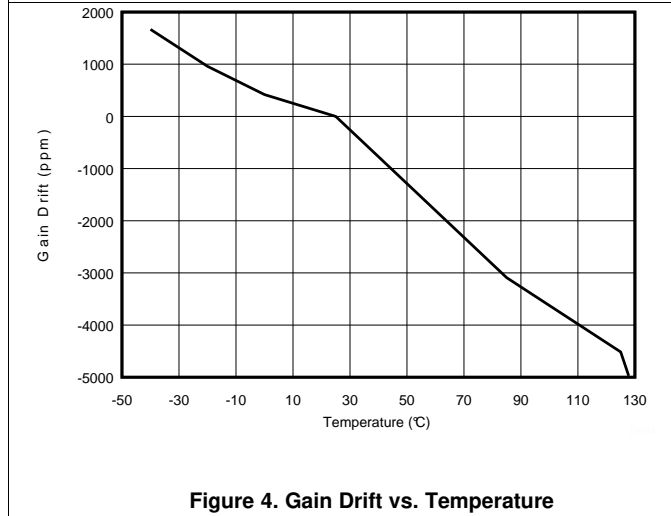
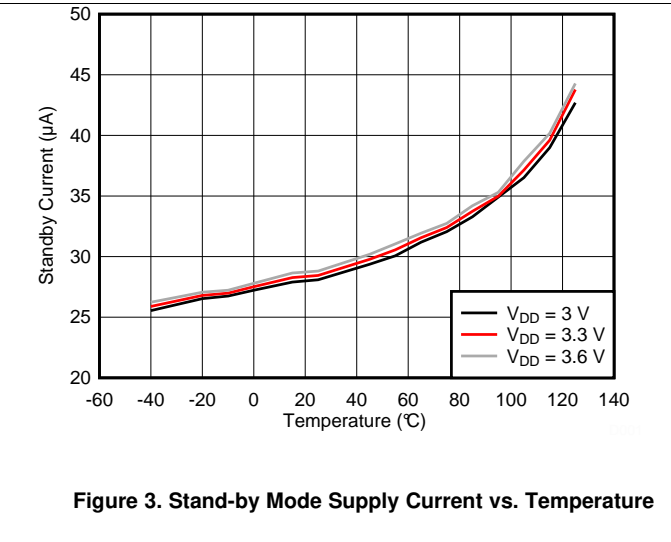
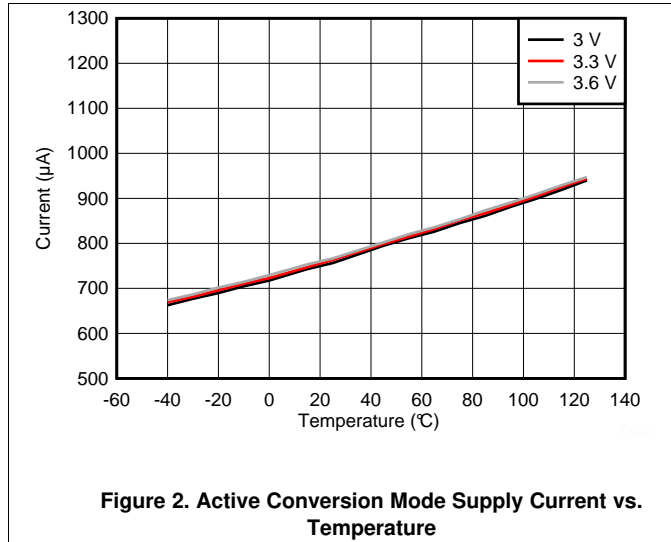
(1) This parameter is specified by design and/or characterization and is not tested in production.

(2) The FDC1004Q provides an internal 300 ns minimum hold time to bridge the undefined region of the falling edge of SCL.

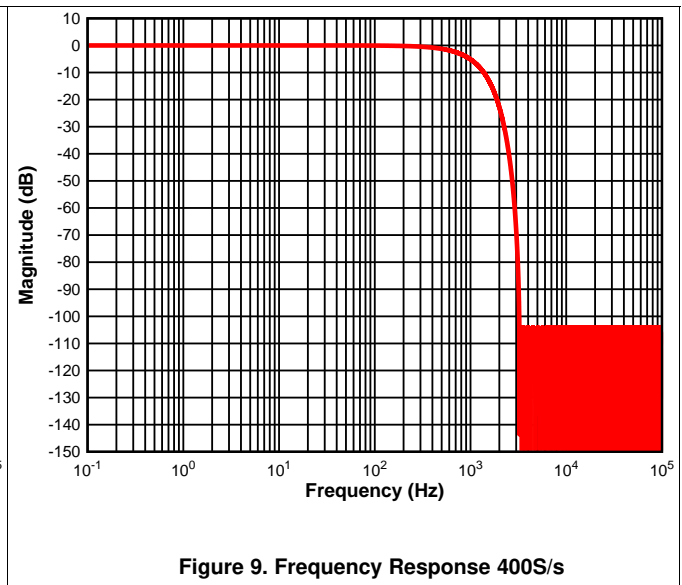
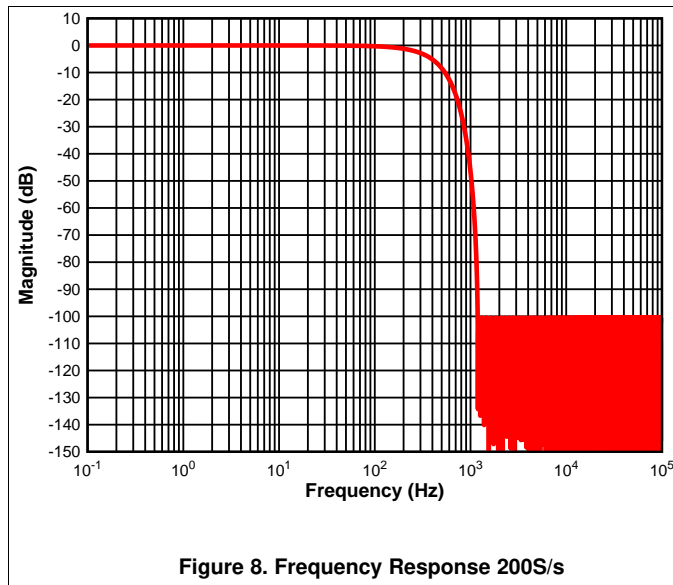


**Figure 1. I<sup>2</sup>C Timing**

## 7.8 Typical Characteristics



**Typical Characteristics (continued)**



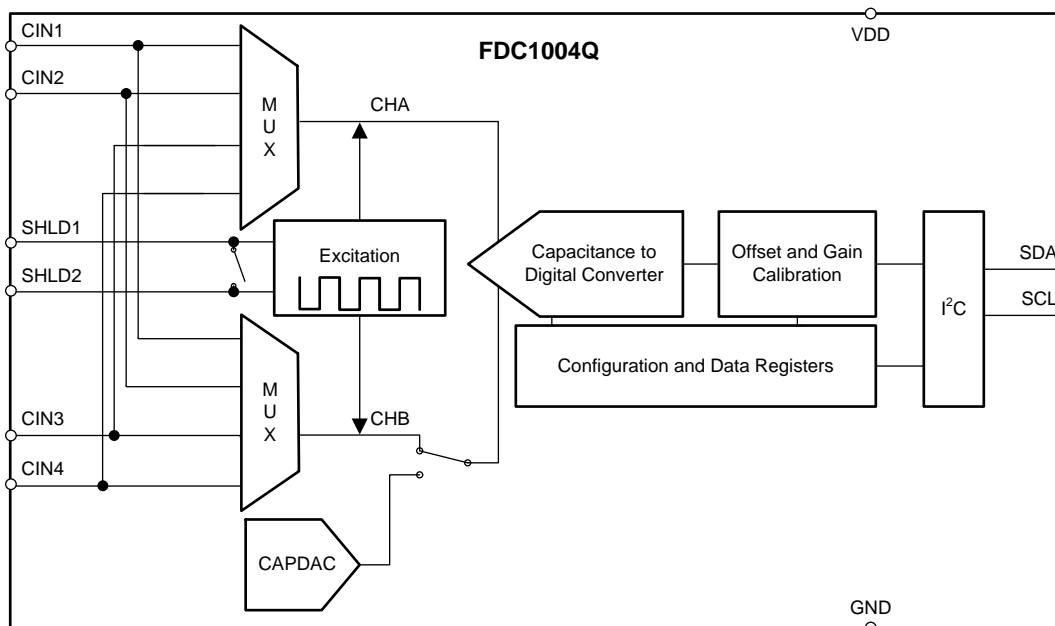


## 8 Detailed Description

### 8.1 Overview

The FDC1004Q is a high-resolution, 4-channel capacitance-to-digital converter for implementing capacitive sensing solutions. Each channel has a full scale range of  $\pm 15$  pF and can handle a sensor offset capacitance of up to 100 pF, which can be either programmed internally or can be an external capacitor for tracking environmental changes over time and temperature. The large offset capacitance capability allows for the use of remote sensors. The FDC1004Q also includes shield drivers for sensor shields, which can reduce EMI interference and help focus the sensing direction of a capacitive sensor. The small footprint of the FDC1004Q allows for use in space-constrained applications. For more information on the basics of capacitive sensing and applications, refer to *FDC1004: Basics of Capacitive Sensing and Applications* application note (SNOA927).

### 8.2 Functional Block Diagram



### 8.3 Feature Description

#### 8.3.1 The Shield

The FDC1004Q measures capacitance between CINn and ground. That means any capacitance to ground on signal path between the FDC1004Q CINn pins and sensor is included in the FDC1004Q conversion result.

In some applications, the parasitic capacitance of the sensor connections can be larger than the capacitance of the sensor. If that parasitic capacitance is stable, it can be treated as a constant capacitive offset. However, the parasitic capacitance of the sensor connections can have significant variation due to environmental changes (such as mechanical movement, temperature shifts, humidity changes). These changes are seen as drift in the conversion result and may significantly compromise the system accuracy.

To eliminate the CINn parasitic capacitance to ground, the FDC1004Q SHLDx signals can be used for shielding the connection between the sensor and CINn. The SHLDx output is the same signal waveform as the excitation of the CINn pin; the SHLDx is driven to the same voltage potential as the CINn pin. Therefore, there is no current between CINn and SHLDx pins, and any capacitance between these pins does not affect the CINn charge transfer. Ideally, the CINn to SHLD capacitance does not have any contribution to the FDC1004Q result.

In differential measurements, SHLD1 is assigned to CHn and SHLD2 is assigned to CHm, where  $n < m$ . For instance in the measurement CIN1 – CIN2, where CHA = CIN1 and CHB = CIN2 (see Table 4), SHDL1 is assigned to CIN1 and SHDL2 is assigned to CIN2.

## Feature Description (continued)

In a single ended configuration, such as CINn vs. GND, SHLD1 is internally shorted to SHLD2. In a single ended configuration, such as CINn vs. GND with CAPDAC enabled, SHLD1 is assigned to the selected channel, SHLD2 is floating.

For best results, locate the FDC1004Q as close as possible to the capacitive sensor. Minimize the connection length between the sensor and FDC1004Q CINn pins and between the sensor ground and the FDC1004Q GND pin. Shield the PCB traces to the CINn pins and connect the shielding to the FDC1004Q SHLDx pins. In addition, if a shielded cable is used to connect the FDC1004Q to the sensor, the shield should be connected to the appropriate SHLDx pin. In applications where only one SHLDx pin is used, the unused SHLDx pin can be left unconnected.

For more information on how to design a sensor with a shield, refer to *Capacitive Sensing: Ins and Outs of Active Sensing* application note ([SNOA926](#)).

### 8.3.2 The CAPDAC

The FDC1004Q full-scale input range is  $\pm 15$  pF. The part can accept a higher capacitance on the input and the common-mode or offset (constant component) capacitance can be balanced by the programmable on-chip CAPDACs. The CAPDAC can be viewed as a negative capacitance connected internally to the CINn pin. The relation between the input capacitance and output data can be expressed as  $DATA = (CINn - CAPDAC)$ ,  $n = 1..4$ . The CAPDACs have a 5-bit resolution, monotonic transfer function, are well matched to each other, and have a defined temperature coefficient.

### 8.3.3 Capacitive System Offset Calibration

The capacitive offset can be due to many factors including the initial capacitance of the sensor, parasitic capacitances of board traces, and the capacitance of any other connections between the sensor and the FDC.

The parasitic capacitances of the FDC1004Q are calibrated out at production. If there are other sources of offset in the system, it may be necessary to calibrate the system capacitance offset in the application. Any offset in the capacitance input larger than  $\frac{1}{2}$  LSB of the CAPDAC should first be removed using the on-chip CAPDACs. Any residual offset of approximately 1 pF can then be removed by using the capacitance offset calibration register. The offset calibration register is reloaded by the default value at power-on or after reset. Therefore, if the offset calibration is not repeated after each system power-up, the calibration coefficient value should be stored by the host controller and reloaded as part of the FDC1004Q setup.

### 8.3.4 Capacitive Gain Calibration

The gain is factory calibrated up to  $\pm 15$  pF in the production for each part individually. The factory gain coefficient is stored in a one-time programmable (OTP) memory.

The gain can be temporarily changed by setting the Gain Calibration Register (registers 0x11 to 0x14) for the appropriate CINn pin, although the factory gain coefficient will be restored after power-up or reset.

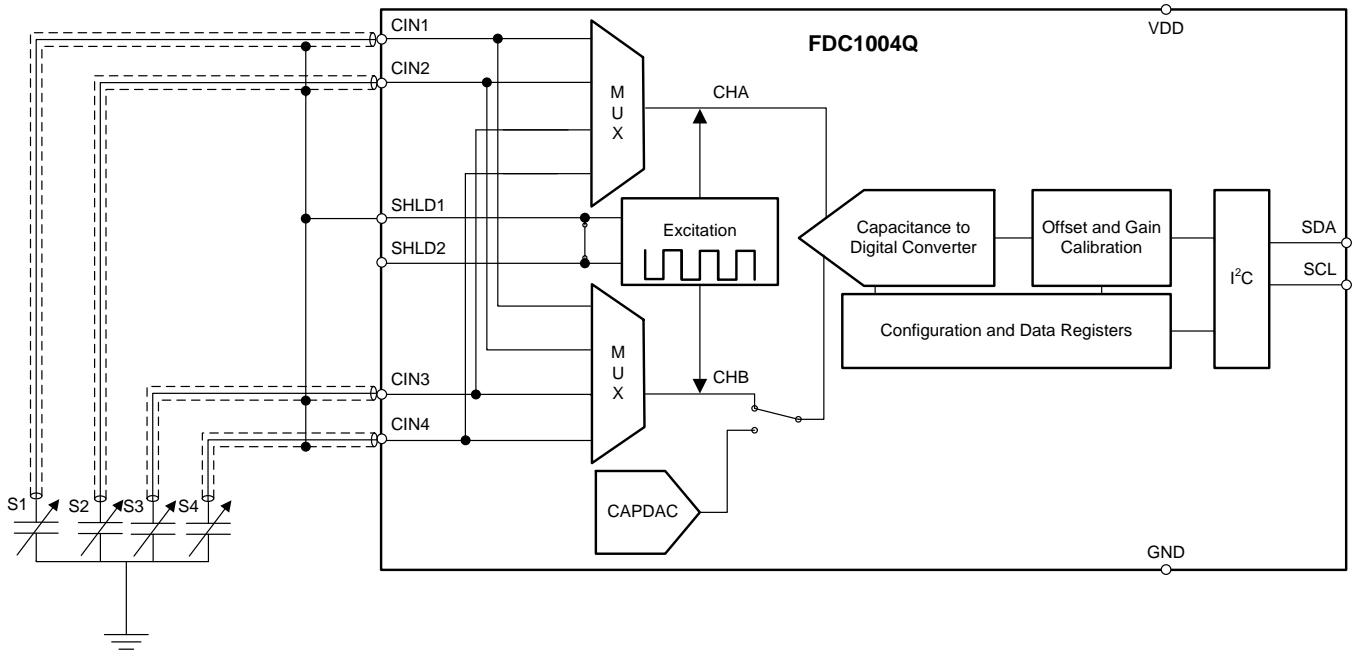
The part is tested and specified for use only with the default factory calibration coefficient. Adjusting the Gain calibration can be used to normalize the capacitance measurement of the CINn input channels.

## 8.4 Device Functional Modes

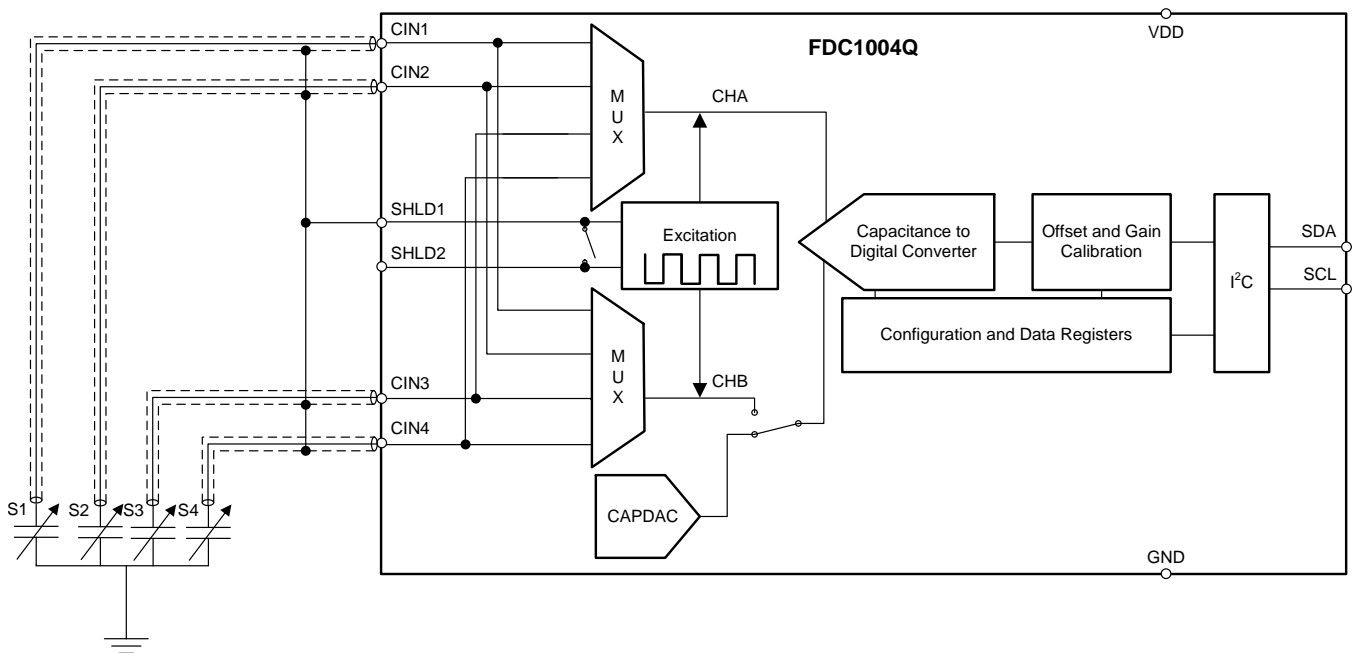
### 8.4.1 Single Ended Measurement

The FDC1004Q can be used for interfacing to a single-ended capacitive sensor. In this configuration the sensor should be connected to the input CINn ( $n = 1..4$ ) pins of the FDC1004Q and GND. The capacitance-to-digital convertor (without using the CAPDAC, CAPDAC= 0pF) measures the positive (or the negative) input capacitance in the range of 0 pF to 15 pF. The CAPDAC can be used for programmable shifting of the input range. In this case it is possible to measure input capacitance in the range of 0 pF to  $\pm 15$  pF which are on top of an offset capacitance up to 100 pF. In single ended measurements with CAPDAC disabled SHLD1 is internally shorted to SHLD2 (see [Figure 10](#)); if CAPDAC is enabled SHLD2 is floating (see [Figure 11](#)). The single ended mode is enabled when the CHB register of the Measurements configuration registers (see [Table 4](#)) are set to b100 or b111.

**Device Functional Modes (continued)**



**Figure 10. Single-Ended Configuration with CAPDAC Disabled**



**Figure 11. Single-Ended Configuration with CAPDAC Enabled**

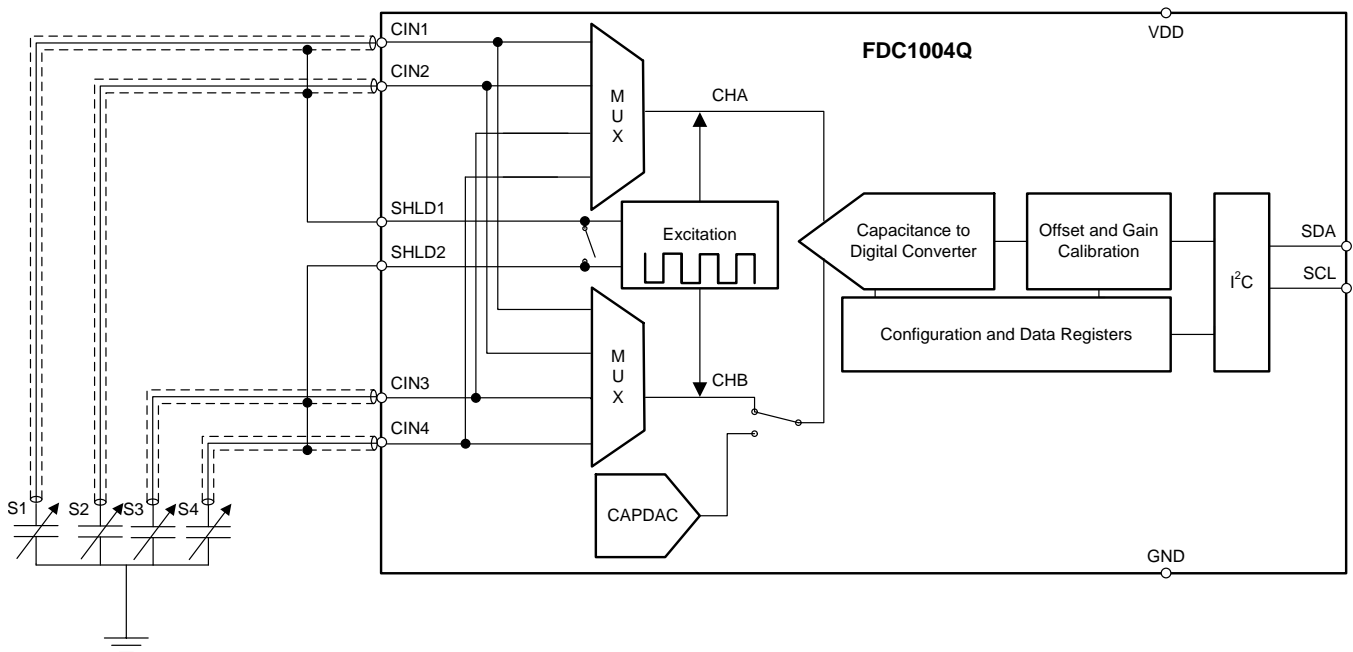
**8.4.2 Differential Measurement**

When the FDC1004Q is used for interfacing to a differential capacitive sensor, each of the two input capacitances must be less than 115 pF. In this configuration the CAPDAC is disabled. The absolute value of the difference between the two input capacitances should be kept below 15 pF to avoid introducing errors in the measurement. In differential measurements, SHLD1 is assigned to CH<sub>n</sub> and SHLD2 is assigned to CH<sub>m</sub>, where n < m. For instance in the measurement CIN1 – CIN2, where CHA = CIN1 and CHB = CIN2 (see Table 4),

## Device Functional Modes (continued)

SHDL1 is assigned to CIN1 and SHDL2 is to CIN2. Differential sensors made with S1 versus S3 and S2 versus S4 are shown below in Figure 12. S1 and S2 are alternatively connected to CHA and the S3 and S4 are alternatively connected to CHB, the shield signals are connected as explained in previous paragraph. The FDC1004Q will perform a differential measurement when CHB field of the Measurements Configuration Registers (refer to Table 4) is less than to b100.

This configuration is very useful in applications where environment conditions need to be tracked. The differential measurement between the main electrode and the environment electrode makes the measurement independent of the environment conditions.



**Figure 12. Differential Configuration**

## 8.5 Programming

The FDC1004Q operates only as a slave device on the two-wire bus interface. Every device on the bus must have a unique address. Connection to the bus is made via the open-drain I/O lines, SDA, and SCL. The SDA and SCL pins feature integrated spike-suppression filters and Schmitt triggers to minimize the effects of input spikes and bus noise. The FDC1004Q supports fast mode frequencies 10 kHz to 400 kHz. All data bytes are transmitted MSB first.

### 8.5.1 Serial Bus Address

To communicate with the FDC1004Q, the master must first address slave devices via a slave address byte. The slave address byte consists of seven address bits and a direction bit that indicates the intent to execute a read or write operation. The seven bit address for the FDC1004Q is (MSB first): b101 0000.

### 8.5.2 Read/Write Operations

Access a particular register on the FDC1004Q by writing the appropriate value to the Pointer Register. The pointer value is the first byte transferred after the slave address byte with the R/W bit low. Every write operation to the FDC1004Q requires a value for the pointer register. When reading from the FDC1004Q, the last value stored in the pointer by a write operation is used to determine which register is read by a read operation. To change the pointer register for a read operation, a new value must be written to the pointer. This transaction is accomplished by issuing the slave address byte with the R/W bit low, followed by the pointer byte. No additional

## Programming (continued)

data is required. The master can then generate a START condition and send the slave address byte with the R/W bit high to initiate the read command. Note that register bytes are sent MSB first, followed by the LSB. A write operation in a read only registers such as MANUFACTURER ID or SERIAL ID returns a NACK after each data byte; read/write operation to unused address returns a NACK after the pointer; a read/write operation with incorrect I<sup>2</sup>C address returns a NACK after the I<sup>2</sup>C address.

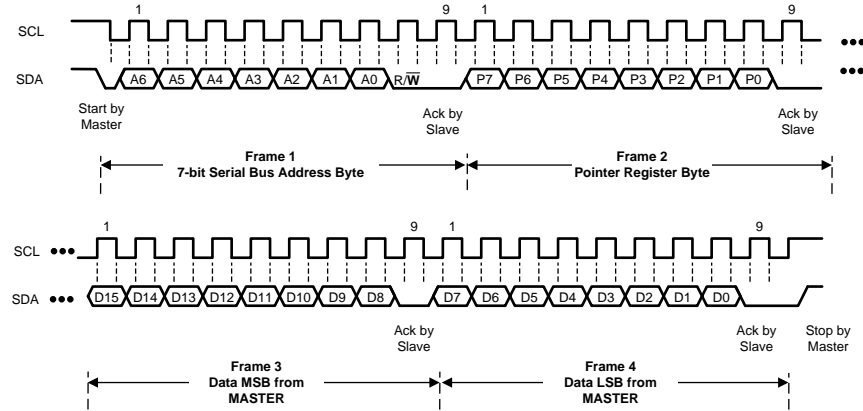


Figure 13. Write Frame

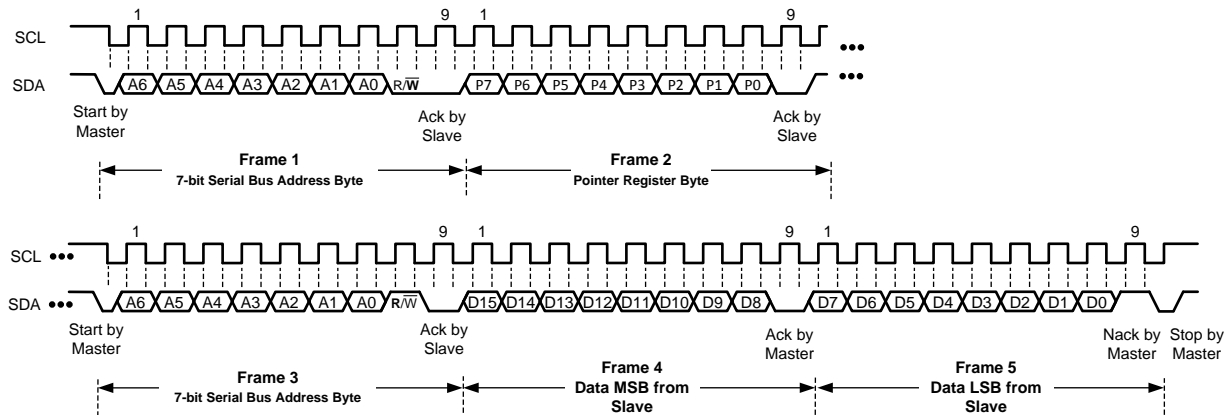


Figure 14. Read Frame

### 8.5.3 Device Usage

The basic usage model of the FDC1004Q is to simply follow these steps:

1. Configure measurements (for details, refer to [Measurement Configuration](#)).
2. Trigger a measurement set (for details, refer to [Triggering Measurements](#)).
3. Wait for measurement completion (for details, refer to [Wait for Measurement Completion](#)).
4. Read measurement data (for details, refer to [Read of Measurement Result](#)).

#### 8.5.3.1 Measurement Configuration

Configuring a measurement involves setting the input channels and the type of measurement (single-ended or differential).

The FDC1004Q can be configured with up to 4 separate measurements, where each measurement can be any valid configuration (that is, a specific channel can be used in multiple measurements). There is a dedicated configuration register for each of the 4 possible measurements (e.g MEAS\_CONF1 in register 0x08 configures measurement 1, MEAS\_CONF2 in register 0x09 configures measurement 2, ...). Configuring only one measurement is allowed, and it can be one of the 4 possible measurement configurations.

## Programming (continued)

1. Setup the input channels for each measurement. Determine which of the 4 measurement configuration registers to use (registers 0x08 to 0x0A) and set the following:
  - (a) For single-ended measurement:
    - (a) Select the positive input pin for the measurement by setting the CHA field (bits[15:13]).
    - (b) Set CAPDAC (bits[9:5]) if the channel offset capacitance is more than 15pF.
  - (b) For a differential measurement:
    - (a) Select the positive input pin for the measurement by setting the CHA field (bits[15:13]).
    - (b) Select the negative input pin for the measurement by setting the CHB field (bits[12:10]). Note that the CAPDAC setting has no effect for a differential measurement.
2. Determine the appropriate sample rate. The sample rate sets the resolution of the measurement. Lower the sample rate higher is the resolution of the measurement.

### 8.5.3.2 Triggering Measurements

For a single measurement, trigger the desired measurement (i.e. which one of the configured measurements) when needed by:

1. Setting REPEAT (Register 0x0C:bit[8]) to 0.
2. Setting the corresponding MEAS\_x field (Register 0x0C:bit[7:4]) to 1.
  - For example, to trigger a single measurement of Measurement 2 at a rate of 100S/s, set Address 0x0C to 0x0540.

Note that, at a given time, only one measurement of the configured measurements can be triggered in this manner (i.e. MEAS\_1 and MEAS\_2 cannot both be triggered in a single operation).

The FDC1004Q can also trigger a new measurement on the completion of the previous measurement (repeated measurements). This is setup by:

1. Setting REPEAT (Register 0x0C:bit[8]) to 1.
2. Setting the corresponding MEAS\_x field (Register 0x0C:bit[7:4]) to 1.

When the FDC1004Q is setup for repeated measurements, multiple configured measurements (up to a maximum of 4) can be performed in this manner, but Register 0x0C must be written in a single transaction.

### 8.5.3.3 Wait for Measurement Completion

Wait for the triggered measurements to complete. When the measurements are complete, the corresponding DONE\_x field (Register 0x0C:bits[3:0]) will be set to 1.

### 8.5.3.4 Read of Measurement Result

Read the result of the measurement from the corresponding registers:

- 0x00/0x01 for Measurement 1
- 0x02/0x03 for Measurement 2
- 0x04/0x05 for Measurement 3
- 0x06/0x07 for Measurement 4

The measurement results span 2 register addresses; both registers must be read to have a complete conversion result. The lower address (e.g. 0x00 for Measurement 1) must be read first, then the upper address read afterwards (for example, 0x01 for Measurement 1).

Once the measurement read is complete, the corresponding DONE\_x field (Register 0x0C:bits[3:0]) will return to 0.

If an additional single triggered measurement is desired, simply perform the Trigger, Wait, Read steps again.

If the FDC1004Q is setup for repeated measurements (Register 0x0C:bit[8]) = 1), the FDC1004Q will continuously measure until the REPEAT field (Register 0x0C:bit[8]) is set to 0, even if the results are not read back.

## 8.6 Register Maps

**Table 1. Register Map**

Pointer	Register Name	Reset Value	Description
0x00	MEAS1_MSB	0x0000	MSB portion of Measurement 1
0x01	MEAS1_LSB	0x0000	LSB portion of Measurement 1
0x02	MEAS2_MSB	0x0000	MSB portion of Measurement 2
0x03	MEAS2_LSB	0x0000	LSB portion of Measurement 2
0x04	MEAS3_MSB	0x0000	MSB portion of Measurement 3
0x05	MEAS3_LSB	0x0000	LSB portion of Measurement 3
0x06	MEAS4_MSB	0x0000	MSB portion of Measurement 4
0x07	MEAS4_LSB	0x0000	LSB portion of Measurement 4
0x08	CONF_MEAS1	0x1C00	Measurement 1 Configuration
0x09	CONF_MEAS2	0x1C00	Measurement 2 Configuration
0x0A	CONF_MEAS3	0x1C00	Measurement 3 Configuration
0x0B	CONF_MEAS4	0x1C00	Measurement 4 Configuration
0x0C	FDC_CONF	0x0000	Capacitance to Digital Configuration
0x0D	OFFSET_CAL_CIN1	0x0000	CIN1 Offset Calibration
0x0E	OFFSET_CAL_CIN2	0x0000	CIN2 Offset Calibration
0x0F	OFFSET_CAL_CIN3	0x0000	CIN3 Offset Calibration
0x10	OFFSET_CAL_CIN4	0x0000	CIN4 Offset Calibration
0x11	GAIN_CAL_CIN1	0x4000	CIN1 Gain Calibration
0x12	GAIN_CAL_CIN2	0x4000	CIN2 Gain Calibration
0x13	GAIN_CAL_CIN3	0x4000	CIN3 Gain Calibration
0x14	GAIN_CAL_CIN4	0x4000	CIN4 Gain Calibration
0xFE	Manufacturer ID	0x5449	ID of Texas Instruments
0xFF	Device ID	0x1004	ID of FDC1004Q device

Registers from 0x15 to 0xFD are reserved and should not be written to.

## 8.6.1 Registers

The FDC1004Q has an 8-bit pointer used to address a given data register. The pointer identifies which of the data registers should respond to a read or write command on the two-wire bus. This register is set with every write command. A write command must be issued to set the proper value in the pointer before executing a read command. The power-on reset (POR) value of the pointer is 0x00.

### 8.6.1.1 Capacitive Measurement Registers

The capacitance measurement registers are 24-bit result registers in binary format (the 8 LSBs D[7:0] are always 0x00). The result of the acquisition is always a 24 bit value, while the accuracy is related to the selected conversion time (refer to ). The data is encoded in a Two's complement format. The result of the measurement can be calculated by the following formula:

$$\text{Capacitance (pf)} = ((\text{Two's Complement (measurement [23:0])}) / 2^{19}) + C_{\text{offset}}$$

where

- $C_{\text{offset}}$  is based on the CAPDAC setting. (1)

**Table 2. Measurement Registers Description (0x00, 0x02, 0x04, 0x06)**

Field Name	Bits	Description
MSB_MEASn <sup>(1)</sup>	[15:0]	Most significant 16 bits of Measurement n (read only)

(1) MSB\_MEAS1 = register 0x00, MSB\_MEAS2 = register 0x02, MSB\_MEAS3 = register 0x04, MSB\_MEAS4 = register 0x06

**Table 3. Measurement Registers Description (0x01, 0x03, 0x05, 0x07)**

Field Name	Bits	Description
LSB_MEASn <sup>(1)</sup>	[15:8]	Least significant 8 bits of Measurement n (read only)
	[7:0]	Reserved Reserved, always 0 (read only)

(1) LSB\_MEAS1 = register 0x01, LSB\_MEAS2 = register 0x03, LSB\_MEAS3 = register 0x05, LSB\_MEAS4 = register 0x07

## 8.6.2 Measurement Configuration Registers

These registers configure the input channels and CAPDAC setting for a measurement.

**Table 4. Measurement Configuration Registers Description (0x08, 0x09, 0x0A, 0x0B)**

Field Name	Bits	Description
CHA <sup>(1)(2)</sup>	[15:13]	Positive input channel capacitive to digital converter
		b000 CIN1
		b001 CIN2
		b010 CIN3
CHB <sup>(1)(2)</sup>	[12:10]	Negative input channel capacitive to digital converter
		b011 CIN4
		b000 CIN1
		b001 CIN2
		b010 CIN3
CAPDAC	[9:5]	Offset Capacitance
		b100 CAPDAC
		b111 DISABLED
RESERVED	[04:00]	Reserved
		b00000 0pF (minimum programmable offset)
		----- Configure the single-ended measurement capacitive offset: $C_{\text{offset}} = \text{CAPDAC} \times 3.125\text{pF}$ b11111 96.875pF (maximum programmable offset)

- (1) It is not permitted to configure a measurement where the CHA field and CHB field hold the same value (for example, if CHA=b010, CHB cannot also be set to b010).
- (2) It is not permitted to configure a differential measurement between CHA and CHB where CHA > CHB (for example, if CHA=b010, CHB cannot be b001 or b000).



### 8.6.3 FDC Configuration Register

This register configures measurement triggering and reports measurement completion.

**Table 5. FDC Register Description (0x0C)**

Field Name	Bits	Description	
RST	[15]	Reset	0 Normal operation
			1 Software reset: write a 1 to initiate a device reset; after completion of reset this field will return to 0
RESERVED	[14:12]	Reserved	Reserved, always 0 (read only)
RATE	[11:10]	Measurement Rate	b00 Reserved
			b01 100S/s
			b10 200S/s
			b11 400S/s
RESERVED	[9]	Reserved	Reserved, always 0 (read only)
REPEAT	[8]	Repeat Measurements	0 Repeat disabled
			1 Repeat enabled, all the enabled measurement are repeated
MEAS_1	[7]	Initiate Measurements	0 Measurement 1 disabled
			1 Measurement 1 enabled
MEAS_2	[6]	Initiate Measurements	0 Measurement 2 disabled
			1 Measurement 2 enabled
MEAS_3	[5]	Initiate Measurements	0 Measurement 3 disabled
			1 Measurement 3 enabled
MEAS_4	[4]	Initiate Measurements	0 Measurement 4 disabled
			1 Measurement 4 enabled
DONE_1	[3]	Measurement Done	0 Measurement 1 not completed
			1 Measurement 1 completed
DONE_2	[2]	Measurement Done	0 Measurement 2 not completed
			1 Measurement 2 completed
DONE_3	[1]	Measurement Done	0 Measurement 3 not completed
			1 Measurement 3 completed
DONE_4	[0]	Measurement Done	0 Measurement 4 not completed
			1 Measurement 4 completed

### 8.6.4 Offset Calibration Registers

These registers configure a digitized capacitance value in the range of -16 pF to 16 pF (max residual offset 250 aF) that can be added to each channel in order to remove parasitic capacitance due to external circuitry. In addition to the offset calibration capacitance which is a fine-tune offset capacitance, it is possible to support a larger offset by using the CAPDAC (for up to 100 pF). These 16-bit registers are formatted as a fixed point number, where the first 5 bits represents the integer portion of the capacitance in Two's complement format, and the remaining 11 bits represent the fractional portion of the capacitance.

**Table 6. Offset Calibration Registers Description (0x0D, 0x0E, 0x0F, 0x10)**

Field Name	Bits	Description	
OFFSET_CALn <sup>(1)</sup>	[15:11]	Integer part	Integer portion of the Offset Calibration of Channel CINn
	[10:0]	Decimal part	Decimal portion of the Offset Calibration of Channel CINn

(1) OFFSET\_CAL1 = register 0x0D, OFFSET\_CAL2 = register 0x0E, OFFSET\_CAL3 = register 0x0F, OFFSET\_CAL4 = register 0x10

### 8.6.5 Gain Calibration Registers

These registers contain a gain factor correction in the range of 0 to 4 that can be applied to each channel in order to remove gain mismatch due to the external circuitry. This 16-bit register is formatted as a fixed point number, where the 2 MSBs of the GAIN\_CALn register correspond to an integer portion of the gain correction, and the remaining 14 bits represent the fractional portion of the gain correction. The result of the conversion represents a number without dimensions.

The Gain can be set according to the following formula:

$$\text{Gain} = \text{GAIN\_CAL}[15:0]/2^{14}$$

**Table 7. Gain Calibration Registers Description (0x11, 0x12, 0x13, 0x14)**

Field Name	Bits	Description	
GAIN_CALn <sup>(1)</sup>	[15:14]	Integer part	Integer portion of the Gain Calibration of Channel CINn
	[13:0]	Decimal part	Decimal portion of the Gain Calibration of Channel CINn

(1) GAIN\_CAL1 = register 0x11, GAIN\_CAL2 = register 0x12, GAIN\_CAL3 = register 0x13, GAIN\_CAL4 = register 0x14

### 8.6.6 Manufacturer ID Register

This register contains a factory-programmable identification value that identifies this device as being manufactured by Texas Instruments. This register distinguishes this device from other devices that are on the same I<sup>2</sup>C bus. The manufacturer ID reads 0x5449.

**Table 8. Manufacturer ID Register Description (0xFE)**

Field Name	Bits	Description	
MANUFACTURER ID	[15:0]	Manufacturer ID	0x5449h Texas instruments ID (read only)

### 8.6.7 Device ID Register

This register contains a factory-programmable identification value that identifies this device as a FDC1004Q. This register distinguishes this device from other devices that are on the same I<sup>2</sup>C bus. The Device ID for the FDC1004Q is 0x1004.

**Table 9. Device ID Register Description (0xFF)**

Field Name	Bits	Description	
DEVICE ID	[15:0]	Device ID	0x1004 FDC1004Q Device ID (read only)

## 9 Applications and Implementation

### NOTE

Information in the following applications sections is not part of the TI component specification, and TI does not warrant its accuracy or completeness. TI's customers are responsible for determining suitability of components for their purposes. Customers should validate and test their design implementation to confirm system functionality.

### 9.1 Application Information

#### 9.1.1 Liquid Level Sensor

The FDC1004Q can be used to measure liquid level in non-conductive containers. Capacitive sensors can be attached to the outside of the container or be located remotely from the container, allowing for contact-less measurements. The working principle is based on a ratiometric measurement; [Figure 15](#) shows a possible system implementation which uses three electrodes. The Level electrode provides a capacitance value proportional to the liquid level. The Reference Environmental electrode and the Reference Liquid electrode are used as references. The Reference Liquid electrode accounts for the liquid dielectric constant and its variation, while the Reference Environmental electrode is used to compensate for any other environmental variations that are not due to the liquid itself. Note that the Reference Environmental electrode and the Reference Liquid electrode are the same physical size ( $h_{REF}$ ).

For this application, single-ended measurements on the appropriate channels are appropriate, as the tank is grounded.

Use the following formula to determine the liquid level from the measured capacitances:

$$Level = h_{ref} \frac{C_{Lev} - C_{Lev}(0)}{C_{RL} - C_{RE}}$$

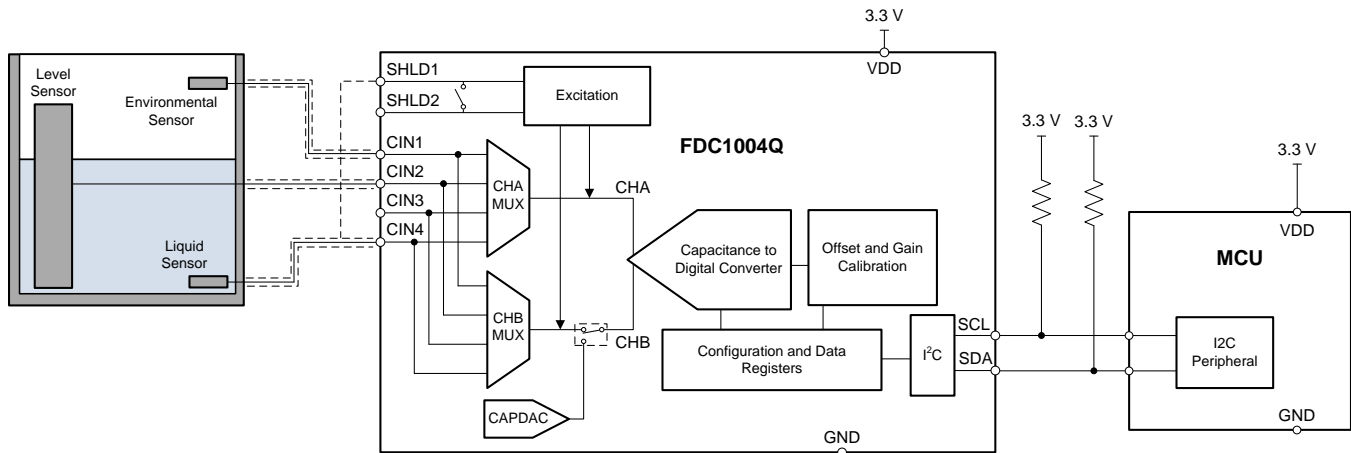
where

- $C_{RE}$  is the capacitance of the Reference Environmental electrode,
- $C_{RL}$  is the capacitance of the Reference Liquid electrode,
- $C_{Lev}$  is the current value of the capacitance measured at the Level electrode sensor,
- $C_{Lev}(0)$  is the capacitance of the Level electrode when the container is empty, and
- $h_{REF}$  is the height in the desired units of the Container or Liquid Reference electrodes.

The ratio between the capacitance of the level and the reference electrodes allows simple calculation of the liquid level inside the container itself. Very high sensitivity values (that is, many LSB/mm) can be obtained due to the high resolution of the FDC1004Q, even when the sensors are located remotely from the container.

For more information on a robust liquid level sensing technique, refer to *Capacitive Sensing: Out-of-Phase Liquid Level Technique* application note ([SNOA925](#)) and the *Capacitive-Based Liquid Level Sensing Sensor Reference Design* ([TIDA-00317](#)).

## 9.2 Typical Application



**Figure 15. FDC1004Q (Liquid Level Measurement)**

### 9.2.1 Design Requirements

The liquid level measurement should be independent of the liquid, which can be achieved using the 3-electrode design described above. Moreover, the sensor should be immune to environmental interferers such as a human body, other objects, or EMI. This can be achieved by shielding the side of the sensor which does not face the container.

### 9.2.2 Detailed Design Procedure

In capacitive sensing systems, the design of the sensor plays an important role in determining system performance and capabilities. In most cases the sensor is simply a metal plate that can be designed on the PCB.

The sensor used in this example is implemented with a two-layer PCB. On the top layer, which faces the tank, there are the 3 electrodes (Reference Environmental, Reference Liquid, and Level) with a ground plane surrounding the electrodes. The bottom layer is covered with a shield plane in order to isolate the electrodes from any external interference sources.

Depending on the shape of the container, the FDC1004Q can be located on the sensor PCB to minimize the length of the traces between the input channels and the sensors and increase the immunity from EMI sources. In case the shape of the container or other mechanical constraints do not allow having the sensors and the FDC1004Q on the same PCB, the traces which connect the channels to the sensor need to be shielded with the appropriate shield. In this design example all of the channels are shielded with SHLD1. For this configuration, the FDC1004Q measures the capacitance of the 3 channels versus ground; and so the SHLD1 and SHLD2 pins are internally shorted in the FDC1004Q (see [The Shield](#)).

### 9.2.3 Application Performance Plot

The data shown below has been collected with the FDC1004QEVM. A liquid level sensor with 3 electrodes like the one shown in the schematic was connected to the EVM. The plot shows the capacitance measured by the 3 electrodes at different levels of liquid in the tank. The capacitance of the Reference Liquid (the RF trace in the graph below) and Reference Environmental (the RE trace) sensors have a steady value when the liquid is above their height while the capacitance of the level sensor (Level) increases linearly with the height of the liquid in the tank.

Typical Application (continued)

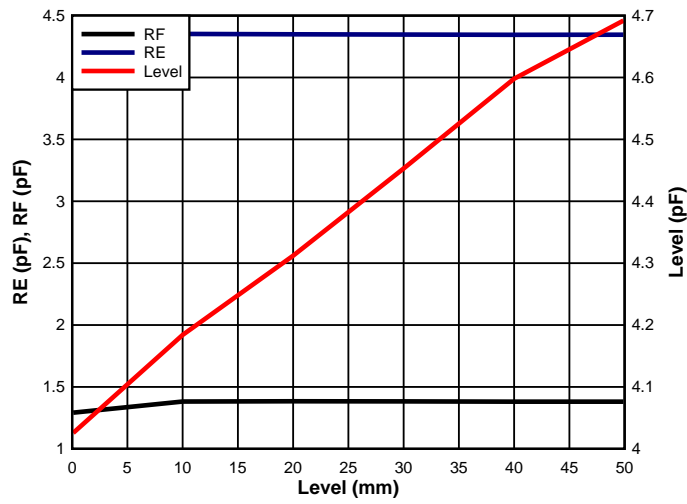


Figure 16. Electrodes' Capacitance vs. Liquid Level

### 9.3 Do's and Don'ts

Avoid long traces to connect the sensor to the FDC1004Q. Short traces reduce parasitic capacitances between shield versus input channel and parasitic resistance between input channel versus GND and shield versus GND.

Since the sensor in many cases is simply a metal surface on a PCB, it needs to be protected with solder resist to avoid short circuits and limit any corrosion. Any change in the sensor may result in a change in system performance.

### 9.4 Initialization Set Up

At power on the device is in stand-by. It stays in this mode until a measurement is triggered.

## 10 Power Supply Recommendations

The FDC1004Q requires a voltage supply within 3 V and 3.6 V. Two multilayer ceramic bypass X7R capacitors of 0.1  $\mu\text{F}$  and 1  $\mu\text{F}$ , respectively between VDD and GND pin are recommended. The 0.1- $\mu\text{F}$  capacitor should be closer to the VDD pin than the 1- $\mu\text{F}$  capacitor.

## 11 Layout

### 11.1 Layout Guidelines

The FDC1004Q measures the capacitances connected between the CINn (n=1..4) pins and GND. To get the best result, locate the FDC1004Q as close as possible to the capacitive sensor. Minimize the connection length between the sensor and FDC1004Q CINn pins and between the sensor ground and the FDC1004Q GND pin. If a shielded cable is used for remote sensor connection, the shield should be connected to the SHLDm (m=1...2) pin according to the configured measurement.

### 11.2 Layout Example

Figure 17 below is optimized for applications where the sensor is not too far from the FDC1004Q. Each channel trace runs between 2 shield traces. This layout allows the measurements of 4 single ended capacitance or 2 differential capacitance. The ground plane needs to be far from the channel traces, it is mandatory around or below the I2C pin.

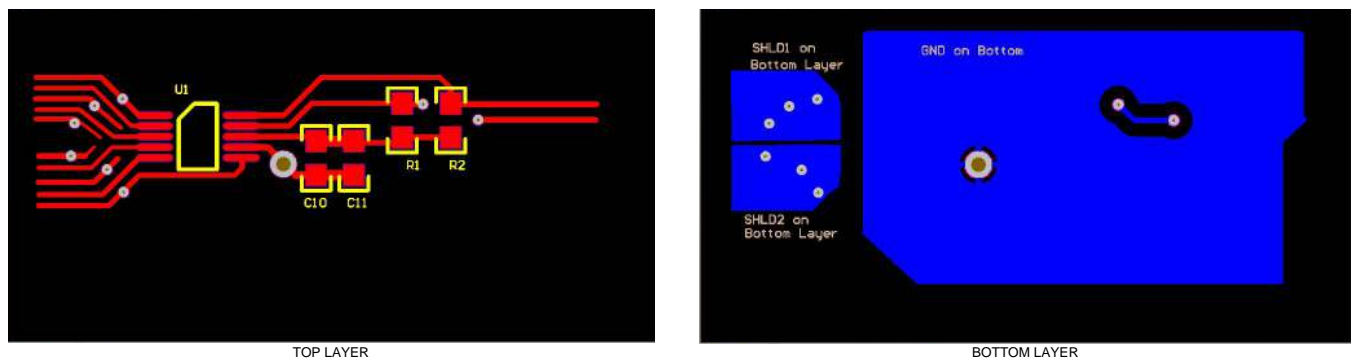


Figure 17. Layout

## 12 Device and Documentation Support

### 12.1 Documentation Support

#### 12.1.1 Related Documentation

IC Package Thermal Metrics application report, [SPRA953](#)

#### Application Notes

*FDC1004: Basics of Capacitive Sensing and Applications* ([SNOA927](#))

*Capacitive Sensing: Ins and Outs of Active Sensing* ([SNOA926](#))

*Capacitive Sensing: Out-of-Phase Liquid Level Technique* ([SNOA925](#))

*Capacitive Proximity Sensing Using the FDC1004* ([SNOA928](#))

*Ice Buildup Detection Using TI's Capacitive Sensing Technology - FDC1004* ([SLLA355](#))

#### TI Reference Designs

*Capacitive-Based Liquid Level Sensing Sensor* ([TIDA-00317](#))

*Automotive Capacitive Proximity Kick to Open Detection* ([TIDA-00506](#))

*Capacitive-Based Human Proximity Detection for System Wake-Up & Interrupt* ([TIDA-00220](#))

*Backlight and Smart Lighting Control by Ambient Light and Proximity Sensor* ([TIDA-00373](#))

### 12.2 Trademarks

All trademarks are the property of their respective owners.

### 12.3 Electrostatic Discharge Caution



These devices have limited built-in ESD protection. The leads should be shorted together or the device placed in conductive foam during storage or handling to prevent electrostatic damage to the MOS gates.

### 12.4 Glossary

[SLYZ022](#) — *TI Glossary*.

This glossary lists and explains terms, acronyms, and definitions.

## 13 Mechanical, Packaging, and Orderable Information

The following pages include mechanical, packaging, and orderable information. This information is the most current data available for the designated devices. This data is subject to change without notice and revision of this document. For browser-based versions of this data sheet, refer to the left-hand navigation.

**PACKAGING INFORMATION**

Orderable Device	Status (1)	Package Type	Package Drawing	Pins	Package Qty	Eco Plan (2)	Lead finish/ Ball material (6)	MSL Peak Temp (3)	Op Temp (°C)	Device Marking (4/5)	Samples
FDC1004QDGSRQ1	ACTIVE	VSSOP	DGS	10	3500	RoHS & Green	SN	Level-1-260C-UNLIM	-40 to 125	ZAOX	<b>Samples</b>
FDC1004QDGSTQ1	ACTIVE	VSSOP	DGS	10	250	RoHS & Green	SN	Level-1-260C-UNLIM	-40 to 125	ZAOX	<b>Samples</b>

(1) The marketing status values are defined as follows:

**ACTIVE:** Product device recommended for new designs.

**LIFEBUY:** TI has announced that the device will be discontinued, and a lifetime-buy period is in effect.

**NRND:** Not recommended for new designs. Device is in production to support existing customers, but TI does not recommend using this part in a new design.

**PREVIEW:** Device has been announced but is not in production. Samples may or may not be available.

**OBSOLETE:** TI has discontinued the production of the device.

(2) **RoHS:** TI defines "RoHS" to mean semiconductor products that are compliant with the current EU RoHS requirements for all 10 RoHS substances, including the requirement that RoHS substance do not exceed 0.1% by weight in homogeneous materials. Where designed to be soldered at high temperatures, "RoHS" products are suitable for use in specified lead-free processes. TI may reference these types of products as "Pb-Free".

**RoHS Exempt:** TI defines "RoHS Exempt" to mean products that contain lead but are compliant with EU RoHS pursuant to a specific EU RoHS exemption.

**Green:** TI defines "Green" to mean the content of Chlorine (Cl) and Bromine (Br) based flame retardants meet JS709B low halogen requirements of <=1000ppm threshold. Antimony trioxide based flame retardants must also meet the <=1000ppm threshold requirement.

(3) MSL, Peak Temp. - The Moisture Sensitivity Level rating according to the JEDEC industry standard classifications, and peak solder temperature.

(4) There may be additional marking, which relates to the logo, the lot trace code information, or the environmental category on the device.

(5) Multiple Device Markings will be inside parentheses. Only one Device Marking contained in parentheses and separated by a "~" will appear on a device. If a line is indented then it is a continuation of the previous line and the two combined represent the entire Device Marking for that device.

(6) Lead finish/Ball material - Orderable Devices may have multiple material finish options. Finish options are separated by a vertical ruled line. Lead finish/Ball material values may wrap to two lines if the finish value exceeds the maximum column width.

**Important Information and Disclaimer:**The information provided on this page represents TI's knowledge and belief as of the date that it is provided. TI bases its knowledge and belief on information provided by third parties, and makes no representation or warranty as to the accuracy of such information. Efforts are underway to better integrate information from third parties. TI has taken and continues to take reasonable steps to provide representative and accurate information but may not have conducted destructive testing or chemical analysis on incoming materials and chemicals. TI and TI suppliers consider certain information to be proprietary, and thus CAS numbers and other limited information may not be available for release.

In no event shall TI's liability arising out of such information exceed the total purchase price of the TI part(s) at issue in this document sold by TI to Customer on an annual basis.



**OTHER QUALIFIED VERSIONS OF FDC1004-Q1 :**

- Catalog: [FDC1004](#)

## NOTE: Qualified Version Definitions:

- Catalog - TI's standard catalog product

**TAPE AND REEL INFORMATION**

**QUADRANT ASSIGNMENTS FOR PIN 1 ORIENTATION IN TAPE**


\*All dimensions are nominal

Device	Package Type	Package Drawing	Pins	SPQ	Reel Diameter (mm)	Reel Width W1 (mm)	A0 (mm)	B0 (mm)	K0 (mm)	P1 (mm)	W (mm)	Pin1 Quadrant
FDC1004QDGSRQ1	VSSOP	DGS	10	3500	330.0	12.4	5.3	3.4	1.4	8.0	12.0	Q1
FDC1004QDGSTQ1	VSSOP	DGS	10	250	178.0	12.4	5.3	3.4	1.4	8.0	12.0	Q1

**TAPE AND REEL BOX DIMENSIONS**


\*All dimensions are nominal

Device	Package Type	Package Drawing	Pins	SPQ	Length (mm)	Width (mm)	Height (mm)
FDC1004QDGSRQ1	VSSOP	DGS	10	3500	367.0	367.0	35.0
FDC1004QDGSTQ1	VSSOP	DGS	10	250	210.0	185.0	35.0

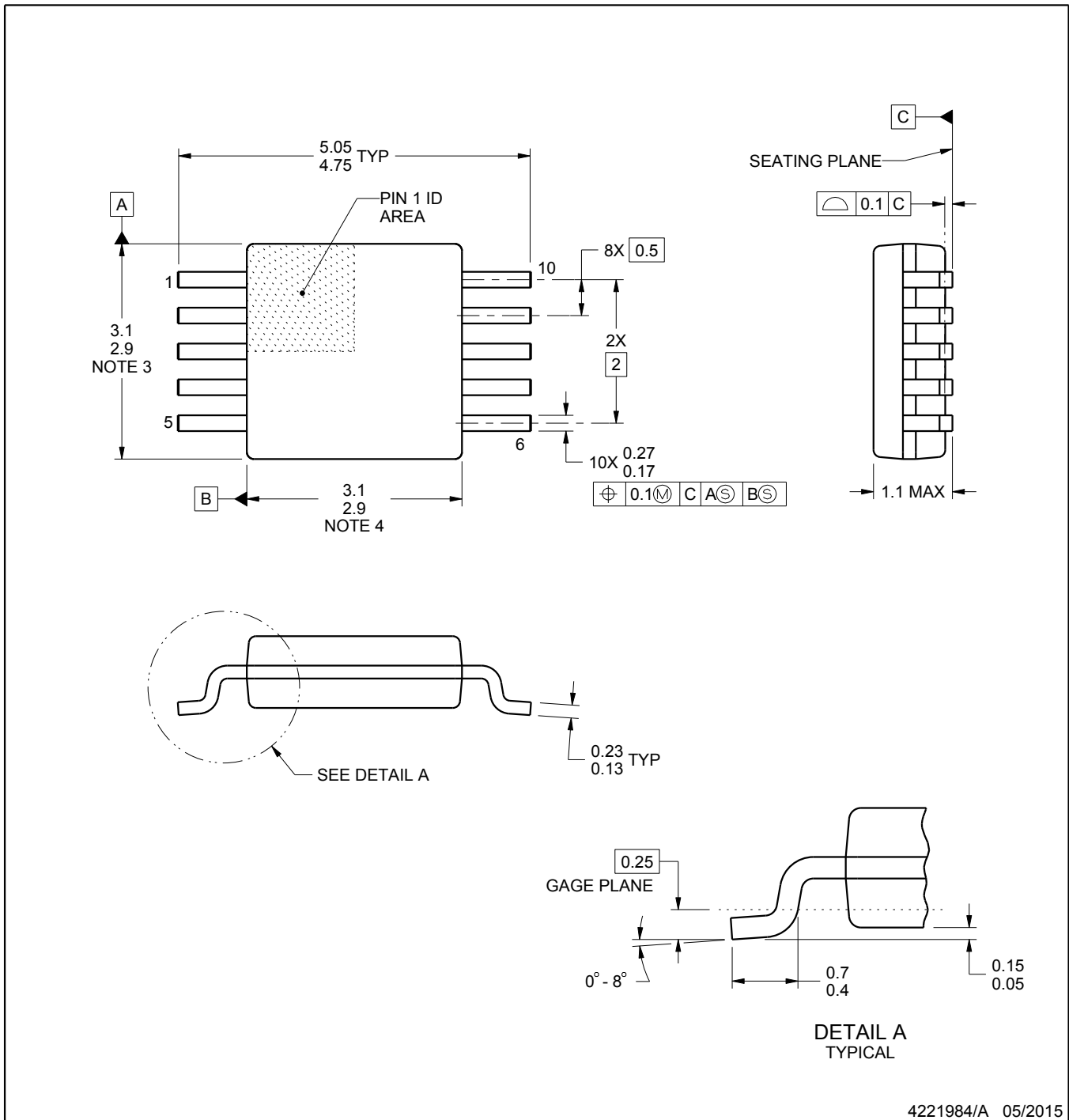
# DGS0010A



# PACKAGE OUTLINE

## VSSOP - 1.1 mm max height

SMALL OUTLINE PACKAGE



4221984/A 05/2015

### NOTES:

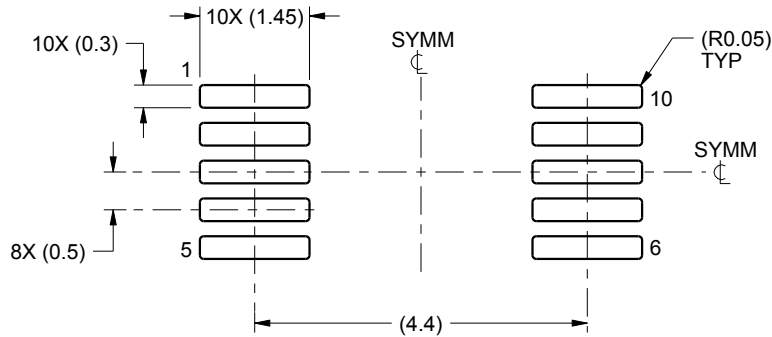
1. All linear dimensions are in millimeters. Any dimensions in parenthesis are for reference only. Dimensioning and tolerancing per ASME Y14.5M.
2. This drawing is subject to change without notice.
3. This dimension does not include mold flash, protrusions, or gate burrs. Mold flash, protrusions, or gate burrs shall not exceed 0.15 mm per side.
4. This dimension does not include interlead flash. Interlead flash shall not exceed 0.25 mm per side.
5. Reference JEDEC registration MO-187, variation BA.

# EXAMPLE BOARD LAYOUT

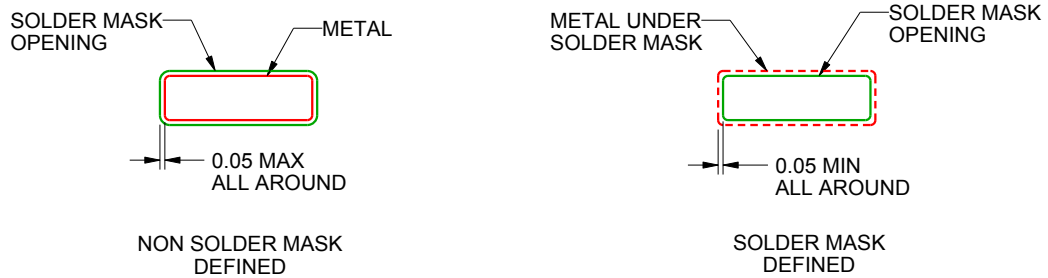
DGS0010A

VSSOP - 1.1 mm max height

SMALL OUTLINE PACKAGE



LAND PATTERN EXAMPLE  
SCALE:10X



SOLDER MASK DETAILS  
NOT TO SCALE

4221984/A 05/2015

NOTES: (continued)

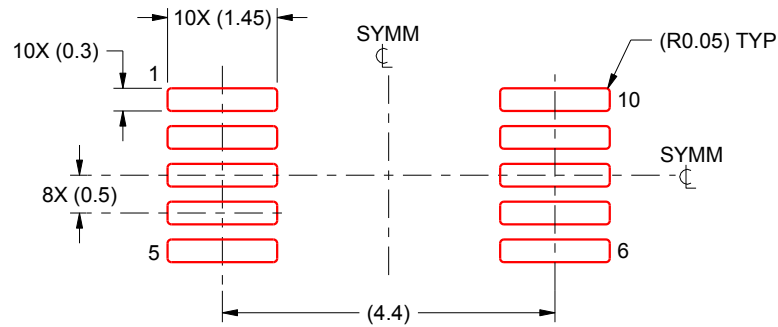
- 6. Publication IPC-7351 may have alternate designs.
- 7. Solder mask tolerances between and around signal pads can vary based on board fabrication site.

# EXAMPLE STENCIL DESIGN

DGS0010A

VSSOP - 1.1 mm max height

SMALL OUTLINE PACKAGE



SOLDER PASTE EXAMPLE  
BASED ON 0.125 mm THICK STENCIL  
SCALE:10X

4221984/A 05/2015

NOTES: (continued)

8. Laser cutting apertures with trapezoidal walls and rounded corners may offer better paste release. IPC-7525 may have alternate design recommendations.
9. Board assembly site may have different recommendations for stencil design.

## IMPORTANT NOTICE AND DISCLAIMER

TI PROVIDES TECHNICAL AND RELIABILITY DATA (INCLUDING DATA SHEETS), DESIGN RESOURCES (INCLUDING REFERENCE DESIGNS), APPLICATION OR OTHER DESIGN ADVICE, WEB TOOLS, SAFETY INFORMATION, AND OTHER RESOURCES "AS IS" AND WITH ALL FAULTS, AND DISCLAIMS ALL WARRANTIES, EXPRESS AND IMPLIED, INCLUDING WITHOUT LIMITATION ANY IMPLIED WARRANTIES OF MERCHANTABILITY, FITNESS FOR A PARTICULAR PURPOSE OR NON-INFRINGEMENT OF THIRD PARTY INTELLECTUAL PROPERTY RIGHTS.

These resources are intended for skilled developers designing with TI products. You are solely responsible for (1) selecting the appropriate TI products for your application, (2) designing, validating and testing your application, and (3) ensuring your application meets applicable standards, and any other safety, security, regulatory or other requirements.

These resources are subject to change without notice. TI grants you permission to use these resources only for development of an application that uses the TI products described in the resource. Other reproduction and display of these resources is prohibited. No license is granted to any other TI intellectual property right or to any third party intellectual property right. TI disclaims responsibility for, and you will fully indemnify TI and its representatives against, any claims, damages, costs, losses, and liabilities arising out of your use of these resources.

TI's products are provided subject to [TI's Terms of Sale](#) or other applicable terms available either on [ti.com](http://ti.com) or provided in conjunction with such TI products. TI's provision of these resources does not expand or otherwise alter TI's applicable warranties or warranty disclaimers for TI products.

TI objects to and rejects any additional or different terms you may have proposed.

Mailing Address: Texas Instruments, Post Office Box 655303, Dallas, Texas 75265  
Copyright © 2022, Texas Instruments Incorporated